

**A.G&S.G.SIDDHARTHA DEGREE COLLEGE OF ARTS & SCIENCE
VUYYURU-521165, KRISHNA Dt., A.P.**

An Autonomous College in the Jurisdiction of Krishna University, Machilipatnam
Accredited by NAAC with “A” Grade ISO9001-2015 Certified Institution

2021-2022

B.SC.AQUACULTURE(Industrial Fisheries)

ODD SEMESTER



DEPARTMENT OF ZOOLOGY

MINUTES OF BOARD OF STUDIES

B.SC.AQUACULTURE

01-11-2021





Minutes of the meeting of Board of studies in Zoology for the Autonomous courses of AG & SG Siddhartha Degree College of Arts & Science, Vuyyuru, held at 2:30 pm on 01-11-2021 in the Department of Zoology.

Smt.D.A. Kiranmayee. ...

Presiding

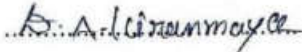
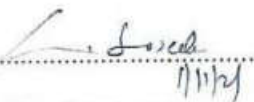
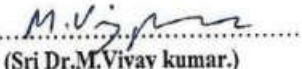
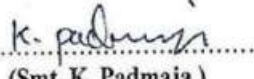
Members Present:

- 1)  Chair person Head, Department of Zoology,
(Smt. D.A.Kiranmayee.) A.G&S.G.S Degree College of
Vuyyuru-521165.
- 2)  University Nominee Bio Sciences & Bio technology
(Smt. Dr.L.Suseela.) Krishna University
Machilipatnam.
- 3)  Academic Council Head,Department of Zoology,
(Sri Dr.M.Viyay kumar.) Nominee SRR & CVR Govt. Degree College,
Vijayawada.
- 4)  Academic Council Head, Department of Zoology,
(Sri Ch. Venkateswaralu.) Nomine P.B. Siddhartha College,
Vijayawada.
- 5)  Member Lecturer in Zoology,
(Smt. K. Padmaja.) A.G&S.G.S Degree College
Vuyyuru-521165.
- 6)  Industrialist Asst. Project Manager,
(B. Appala Naidu.) RGCA
Manikonda.
- 7)  Student Represent P.hd –Research Scholar,
(Ch.Chiranjeevil) Dept.of Botany & Microbiology,
Acharya Nagarjuna University,
Guntur.

AQUACULTURE

Agenda for B.O.S Meeting.

1. To recommend the syllabi (Theory & Practical), Model question paper for I Semester of I B.Sc (A.B.C) for the academic year 2021-2022.
2. To recommend the syllabi (Theory & Practical), Model question paper for III Semester of II B.Sc (A.B.C) for the academic year 2021-2022.
3. To recommend the syllabi (Theory & Practical), Model question paper for V Semester of III B.Sc (A.B.C) for the academic year 2021-2022.
4. To recommend the syllabi (Theory & Practical), Model question paper and Blue print of I, III & V semester of I, II, III B.Sc (A.B.C.) for the academic year 2021-2022.
5. To recommend the teaching and evaluation methods to be followed under Autonomous statues.
6. Any other matter.

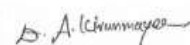

Chairman.

RESOLUTIONS

1. It is resolved to implement the changed syllabi (Theory & Practical), model question paper of I Semester of I B.Sc. (A.B.C) under Choice Based Credit System (CBCS) for the academic Year 2021 – 2022.
2. It is resolved to implement the changed syllabi (Theory & Practical), model question paper of III Semester of II B.Sc. (A.B.C) under Choice Based Credit System (CBCS) for the academic Year 2021 – 2022.
3. It is resolved to follow the newly framed syllabi (Theory & Practical), model question paper of Semester of III B.Sc. (A.B.C) under Choice Based Credit System (CBCS) for the academic Year 2021 – 2022.
4. It is resolved to follow the Model question paper and Blue print of I,III& V semester of I,II& III B.Sc (A.B.C.) for the academic year 2021-2022.
5. It is resolved to introduce Value Added Course in Sericulture to I B.Sc. Aqua Students
6. It is resolved to continue the following teaching & evaluation methods for the Academic year 2021-22.

Teaching methods:

Besides the conventional methods of teaching, we use modern technology i.e. Using of OHP and LCD projector to display on U boards etc; for better understanding of concepts.

Evaluation of a student is done by the following procedure:

❖ Internal Assessment Examination:

- ❖ Out of maximum 100 marks in each paper for II & III B.Sc(A.B.C) 30 marks shall be allocated for internal assessment.
- ❖ Out of these 30 marks, 20 marks are allocated for announced tests (i.e . IA-1& IA-2). Two announced tests will be conducted and average of these two tests shall be deemed as the marks obtained by the student, 5 marks are allocated on the basis of candidate's percentage of attendance and remaining 5 marks are allocated for the assignment for I,II& III B.Sc (A.B.C).
- ❖ Out of maximum 100 marks in each paper for I B.Sc(A.B.C) 25 marks shall be allocated for internal assessment.
- ❖ Out of these 25 marks, 20 marks are allocated for announced tests (i.e . IA-1& IA-2). Two announced tests will be conducted and average of these two tests shall be deemed as the marks obtained by the student, 5 marks are allocated on the basis of candidate's percentage of attendance / assignment for I, semester.
- ❖ There is no pass minimum for internal assessment for I, II, III B.Sc

❖ Semester – End Examination:

- ❖ The maximum mark for I (ABC) semester – End examination shall be 75 marks and duration of the examination shall be 3 hours.
- ❖ The maximum mark for III, V (A.B.C) semester – End examination shall be 70 marks and duration of the examination shall be 3 hours. Even though the candidate is absent for two IA exams/ obtain Zero marks the external marks are considered (if the candidate gets 40/70) and the result shall be declared as “PASS”.
- ❖ Semester – End examination shall be conducted in theory papers at the end of every semester, while in practical papers, these examinations are conducted at the end of I, III & V semester for I, II & III B.Sc, (A.B.C).

B. Achimayee

**ADUSUMILLI GOPALAKRISHNAIAH & SUGAR CANE GROWERS SIDDHARTHA DEGREE
COLLEGE OF ARTS & SCIENCE, VUYURU-521165, KRISHNA Dt., A.P. (AUTONOMOUS).**

ALLOCATION OF CREDITS

Structure of AQUACULTURE Syllabus

For the Papers offered during I,III & V Semesters

<i>Year</i>	<i>Semester</i>	<i>Title</i>	<i>Teaching hours</i>	<i>Internal marks</i>	<i>External marks</i>	<i>Credits</i>
I	I	Basic Principles of Aquaculture	4	25	75	03
		Practical - I	2	10	40	01
II	III	Fresh water & Brackish water Aquaculture	4	30	70	03
		Practical -III	2	25	25	01
III	V(501)	Fish health Management	4	30	70	03
		Practical - 501p	2	25	25	01
	V(502)	Extension, Economics & Marketing	4	30	70	03
		Practical - 502p	2	25	25	01
		Total Credits				16

**ADUSUMILLI GOPALAKRISHNAIAH & SUGAR CANE GROWERS SIDDHARTHA
DEGREE COLLEGE OF ARTS & SCIENCE, VUYURU-521165, KRISHNA Dt., A.P.
(AUTONOMOUS).**

NACC reaccredited at 'A' level
Autonomous –ISO 9001-2015 Certified

Title of the Paper: **Basic Principles of Aquaculture**

Semester: - I

Course Code	AQUT11A	Course Delivery Method	Class Room/Blended Mode - Both
Credits	3	CIA Marks	25
No. of Lecture Hours/Week	4	Semester End Exam Marks	75
Total Number of Lecture Hours	60	Total Marks	100
Year of Introduction : 2019-20	Year of Offering 2019-2020	Year of Revision – 2021-22	Percentage of Revision: 70%

AIM

- To know the basic principles of Aquaculture.

OBJECTIVES

- To study the concept of blue revolution and its impact at global, national and state level.
- To get acquainted with different culture systems and culture methods.
- To study the different types of ponds used in culture practices.
- To study the criteria for construction of ideal fish pond.
- To study the management practices in fish/ prawn culture.

PREREQUISITE

- Knowledge of fisheries management acquired in Intermediate.

COURSE OUTCOMES

By the end of the course students will be able to

CO 1	Understand the concept of blue revolution, analyse the history and compare the present status of aquaculture at global, national and state levels and its significance over agriculture and gain knowledge in the various aquaculture resources and advantages of culture over capture.
CO 2	Acquire knowledge in the different types of aquaculture, culture systems and culture methods in practice worldwide.
CO 3	Gain knowledge in the different types of culture ponds.
CO 4	Understand the arrangement of different types of ponds in a fish farm and design an ideal fish farm.
CO 5	Comprehend the best management practices to be adopted in aquaculture for good yield and acquire the skill in the analysis of water and soil parameters of a culture pond.
CO 6	Identify the different types of weeds and predators in a culture pond and suggest the suitable control measures for their eradication.

Syllabus

Unit	Learning Units	Lecture Hours
I	UNIT-I (Introduction) Definition and History of Aquaculture Concept of Blue Revolution and Pradhan Mantri Matsya Sampada Yojana (PMMSY) Present status of Aquaculture at global level, India and Andhra Pradesh Aquaculture versus Agriculture; Present day needs with special reference to Andhra Pradesh Aquaculture resources: Ponds, tanks, lakes, reservoirs etc Capture and Culture fisheries; Advantages of culture fishery over capture fishery	11
II	UNIT-II (Types of Fish Ponds) Lotic and lentic systems, streams and springs Classification of ponds based on water resources – spring, rain water, flood water, well water and water course ponds Functional classification of ponds – head pond, hatchery, nursery, rearing, production and stocking ponds; quarantine ponds, isolation ponds and wintering ponds; Hatchery design	11
III	UNIT- III (Design and Construction of Aqua Farms) Important factors in the construction of an ideal fish pond – site selection, topography, nature of the soil, water resources Lay out and arrangement of ponds in a fish farm Construction of an ideal fish pond – space allocation, structure and components of barrage Pond	10
IV	UNIT-IV (Aquaculture Systems and Practices) Types of aquaculture Fresh water aquaculture , Brackish water aquaculture , Mariculture Aquaculture Systems – Pond, Raceways, Cage, Pen, Rafts, Running water, Water Recirculating Systems, Biofloc Technology and 3-C System Pond culture practices- Traditional, Extensive, Modified Extensive, Semi-Intensive, Intensive & Super-intensive systems of fish and shrimp and their significance. Fin fish culture methods - Monoculture, Polyculture and Monosex culture and Integrated fish farming.	12
V	UNIT-IV (Management Factors of Culture Ponds) Pre-stocking Management Dewatering, drying, ploughing/desilting Liming and fertilization; Need of fertilizer and manure application, NPK contents of different fertilizers and manures and precautions in their Application Predators, weeds and weed fish in culture ponds - Advantages and disadvantages of weed plants; Toxins used for weed control and control of predators. Algal blooms and their control Stocking Management – Stocking density and stocking Post-stocking Management Feeding: Role of nutrients Water quality: Physico-chemical conditions of soil and water optimum for culture temperature, depth, turbidity, light, water and shore currents, PH, DOD, CO ₂ , NH ₃ , NO ₂ and nutrients . Measures to increase oxygen and reduce ammonia & hydrogen sulphide in culture ponds; correction of PH	14

PRESCRIBED BOOK(S):

1. Jhingran VG 1998. Fish and Fisheries of India. Hindusthan Publishing Corporation, New Delhi
2. Pillay TVR, 1996. Aquaculture Principles and Practices, Fishing News Books Ltd., London

REFERENCES:

1. Pillay TVR & M.A. Dill, 1979. Advances in Aquaculture. Fishing News Books Ltd., London
2. Stickney RR 1979. Principles of Warm Water Aquaculture. John Wiley & Sons Inc. 1981
3. Boyd CE 1982. Water Quality Management for Pond Fish Culture. Elsevier Scientific Publishing
4. Bose AN et al., 1991. Coastal Aquaculture Engineering. Oxford & IBH Publishing Company.

CO-CURRICULAR ACTIVITIES

1. Collection of data on present status of aquaculture
2. Animal album-making
 - a. Plankton
 - b. Aquatic weeds
 - c. Aquatic Insects
 - d. Algal Blooms
 - e. Weed and Predatory fish
3. Preparation of clay models of different ponds in a fish farm.
4. Field survey of nearby habitat for dietary dependency on and requirement of aqua-products
5. Collection of water and soil samples and estimation of various parameters.
6. Preparation of charts on aeration devices.
7. Collection of different culture species stage-wise {spawn, fry, fingerlings, zero size and adult (more than 200 g)}

I SEMESTER END EXAMINATIONS

PAPER – I MODEL PAPER
Title of the paper: Basic Principles of Aquaculture

Course Code: AQUT11A

Time: 3 Hours

Max. Marks: 75

SECTION –A

Draw neat labeled diagrams wherever necessary.

Answer and FIVE of the following

5x5=25 Marks

1. Explain the significance of Biofloc Technology CO2, L2
2. Explain the concept of blue revolution CO1, L2
3. What is Mari culture?CO2, L1
4. Explain the importance of pond fertilization. CO5, L2
5. Explain the functional role of Rearing and Stocking ponds CO3, L2
6. Mention the criteria for site selection of an ideal fish pond CO4, L1
7. Analyze the control measures for weed fish in culture ponds CO6, L4
8. Justify the role of nutrients in a fish pond. CO5, L5

SECTION – B

Answer the following questions.

5X10=50 Marks

9. Define capture and culture fisheries. List out the advantages of culture fishery over capture fishery. CO1, L1

OR

Mention the present status of Aquaculture at global level, India and Andhra Pradesh.CO1, L1

10. Explain the different types of freshwater aquaculture. CO2, L2

OR

Describe the different types of pond culture methods. CO2, L2

11. Give an account of the different types of hatcheries and describe the design of a modern hatchery. CO4, L2

OR

Classify ponds based on water resources. CO4, L2

12. Describe the structure and components of a barrage pond. CO4, L1

OR

Describe the lay out and arrangement of nursery pond in a fish farm. CO4, L1

13. Analyze the physico-chemical conditions of water optimum for fish culture. CO5, L4

OR

Write an essay on aquatic weed plants in a fish pond, their advantages and disadvantages. CO6, L4

PRACTICAL- I (At the end of I Semester)

Title of the paper: Basic Principles of Aquaculture.

No of Hours: 30

Credits: 01

WEF: 2021-2022 Course Code: AQU P11A

LEARNING OUTCOMES:

By the end of the course students will be able to

Identify the various live food organisms in the culture ponds.

Identify the aquatic weeds, insects and weed fish causing damage to the cultured animals and suggest measures to control the algal blooms in culture ponds.

Understand the mechanism of aeration devices used in culture ponds.

Develop skill in analysing the various water and soil parameters.

Gain practical knowledge in the management of different types of ponds in a fish farm.

Understand the importance of preservation of museum specimens and identify the animals based on special identifying characters.

Maintain a neat, labeled record of identified museum specimens and exhibit the hidden creative talent.

1. Estimation of Carbonates, Bicarbonates in water samples
2. Estimation of Chlorides in water samples
3. Estimation of Dissolved Oxygen
4. Estimation of Ammonia in water.
5. Estimation of Total Hardness of water sample.
6. Determination of soil Nitrogen and Phosphorus.
7. Study of beneficial and harmful algal species
8. Study of aeration devices
9. Collection, identification and isolation of zooplankton and phytoplankton
10. Collection and study of aquatic weeds, aquatic insects, weed fish and larvivorous fish
11. Study of fish species banned from culture (*Clarius gariepinus*,
Hypostomus plecostomus)
12. Field visit to hatchery, nursery, rearing and stocking ponds of aqua farms.

PRESCRIBED BOOK(S):

1. Jhingran VG 1998. Fish and Fisheries of India, Hindustan Publishing Corporation, New Delhi
2. Pillay TVR, 1996. Aquaculture Principles and Practices, Fishing News Books Ltd., London

REFERENCES

1. Boyd CE. 1979. *Water Quality in Warm Water Fish Ponds*. Auburn University
2. Boyd, CE. 1982. *Water Quality Management for Pond Fish Culture*. Elsevier Sci. Publ. Co.
3. FAO. 2007. *Manual on Freshwater Prawn Farming*.
4. ICAR. 2006. *Hand Book of Fisheries and Aquaculture*. ICAR.
5. Lovell RT.1998. *Nutrition and Feeding of fishes*.Chapman& Hall.
6. Mevey JP. 1983. *Handbook of Mariculture*. CRC Press.
7. MPEDA: *Handbooks on culture of carp, shrimp, etc.*
8. Bose AN et.al., 1991. *Costal Aquaculture Engineering*.Oxford & IBH Publishing CompanyPvt.Ltd.
- 9.Stickney RR 1979. *Principles of Warm Water Aquaculture*. John Wiley & Sons Inc.1981
10. Pillay TVR &M.A.Dill, 1979.*Advances in Aquaculture*. Fishing News Books Ltd., London

ADUSUMILLI GOPALAKRISHNAIAH & SUGAR CANE GROWERS SIDDHARTHA DEGREE COLLEGE OF ARTS & SCIENCE, VUYYURU-521165, KRISHNA Dt., A.P. (AUTONOMOUS).

I B.Sc AQUACULTURE PRACTICAL EXAMINATION

Practical - I

Course Code: AQU P11A

Title of the paper:Basic Principles of Aquaculture

Time: 3hrs.

Max. Marks 40M

I. Estimate the amount of Chlorides/ Dissolved Oxygen/Free Carbon dioxide /Total Hardness of the given sample. CO4, L5 **10 M**

Procedure: 5M

Calculations: 3M

Report: 2M

II. Identify, draw labelled diagram, classify and comment on CO1, CO2, CO6, L3 **5x3=15 M**

A. Algal Blooms

Identification : 1M

B. Plankton

Diagram :1/2 M

C. Aquatic weed

Notes : 11/2M

D. Aquatic Insect

E. Weed Fish

III. Practical Record Book CO7, L3 **5M**

IV. Field note Book CO5, L1 **5M**

V. VIVA CO7, L5 **5M**

**ADUSUMILLI GOPALAKRISHNAIAH & SUGAR CANE GROWERS SIDDHARTHA
DEGREE COLLEGE OF ARTS & SCIENCE, VUYURU-521165, KRISHNA Dt., A.P.
(AUTONOMOUS).**

NACC reaccredited at 'A' level
Autonomous –ISO 9001-2015 Certified

Title of the Paper: **Fresh water & Brackish water Aquaculture**

Semester: - III

Course Code	AQU-301C	Course Delivery Method	Class Room/Blended Mode - Both
Credits	3	CIA Marks	30
No. of Lecture Hours/ Week	4	Semester End Exam Marks	70
Total Number of Lecture Hours	60	Total Marks	100
Year of Introduction : 2021-2022	Year of Offering 2021-2022	Year of Revision –	Percentage of Revision:

Objective of the course: The students understand Fresh water & Brackish water Aquaculture.

Course outcomes:

CO1: Learn the Status, Scope and Prospects of fresh water aquaculture in the world, India and AP.

CO2: Learn about Major Cultivable Indian Carps and Exotic fish Species introduced in India

CO3: Know about recent developments in the culture of clarius, anabas and murrels and special systems of aquaculture.

CO4: Gain knowledge of commercially valuable Fresh water prawns of India and their culturing methods.

CO5: Learn about culturing of brackish water Prawn Species *P. mondon* and *L. vannamei* and hatchery technology's involved

Learning Objectives:

- To know the present status of freshwater and brackish water aquaculture and their role in world economy and food production.
- To gain knowledge on carp, prawn, shrimp and crab culture and composite fish culture systems.
- To improve the technical knowledge on fish and shrimp hatchery technology and culture practices.
- To improve the knowledge and technical skills for the identification of cultivable fin fish and shell fish.

Syllabus
Course Details

Unit	Learning Units	Lecture Hours
I	<p>UNIT- I: Introduction Status, scope and prospects of freshwater aquaculture in the world, India and AP Status, scope and prospects of brackish water aquaculture in the world, India and AP Freshwater and brackish water resources in India. Special culture systems - brief study of culture in running water, recirculatory systems, cages and pens, sewage-fed fish culture.</p>	10
II	<p>UNIT-II: Culture of carp, air-breathing, and exotic fishes Bundh breeding and Induced breeding of Indian major carp by hypophysation technique .Synthetic harmones used for induced breeding of carps. Types of fish hatcheries- traditional, Chinese and jar hatcheries. Preparation and Management of Indian major carp culture ponds – nursery, rearing and grow-out ponds. Culture of air-breathing fishes in India; Pangasius fish farmin Exotic fishes introduced to India and their impact on indigenous species. Composite fish culture of Indian and exotic carps – compatibility and competition.</p>	10
III	<p>UNIT-III: Culture of prawn and ornamental fishes Breeding and hatchery management of freshwater prawn, Macrobrachium rosenbergii. Culture of Macrobrachium rosenbergii and M. malcolmsonii – biology, seed production, pond preparation, stocking, management, feeding, morph types and harvesting. Ornamental fish culture– Common freshwater and marine ornamental fishes; Fabrication, setting up and maintenance of freshwater and marine aquarium. Breeding and rearing of freshwater ornamental fishes.</p>	15
IV	<p>UNIT-IV: Culture of shrimp and crab Breeding and Hatchery management of a typical penaeid shrimp (Penaeus monodon or Litopenaeus vannamei) Transportation of shrimp seed and nursery management. Culture of P. mondon or L. vannamei –pond preparation, stocking, management of water, feedand diseases, and harvesting. Culture of mud crab, Scylla serrata.</p>	15
V	<p>UNIT-V: Culture of brackish water fishes Breeding and Culture of milk fish, Chanos chanos. Breeding and Culture of Asian sea bass, Lates calcarifer. Breeding and Culture of grey mullet, Mugil cephalus. Fish and shellfish culture in cages and pens.</p>	10

**A.G. & S.G.Siddhartha Degree College of Arts & Science, Vuyyuru – 521165,
Krishna Dt. A.P. (Autonomous)**

**Semester –III
w.e.f. 2021-2022**

Time: 3hrs

Model question paper

Title of the paper: Fresh water & Brackish water Aquaculture.

Code – AQU-301C

max.marks: 70

Section – A

Answer any **four** questions. Each question carries **five** marks.

4 x 5= 20.

Draw neat labeled diagrams wherever necessary.

1. Freshwater culture systems
2. Cages
3. Bundh breeding
4. Nursery pond
5. Seed production
6. Feed and diseases
7. Harvesting
8. Chanos chanos

Section – B

Answer any **five** questions. Each question carries **Ten** marks.

5 x 10 =50

Draw neat labeled diagrams wherever necessary.

9. Describe the status and prospects of freshwater aquaculture in A.P.?
10. Write an essay on major cultivable Indian carps
11. Explain recent culture trends in murrels
12. . Describe composite fish culture system of Indian and exotic carps
13. Explain advantages in the culture of air-breathing fishes.
- 14 Write an essay on the commercial value of Indian freshwater prawn.
15. Breeding and Culture of milk fish

SEMESTER-III

Guide lines to the paper setter
Max.Marks:70

Time: 3 hrs

Paper Title: - Fresh water & Brackish water Aquaculture.

Paper Code: AQU-301C

Note:1. Answer **any four** questions out of eight in Part-A. Each question carries five marks.
4X 5 = 20M.

2. Answer any **five** questions out of eight in Part-B. Each question carries 10 marks.5 X 10 =
50M.

	PART	Unit –I	Unit – II	Unit-III	Unit – IV	Unit – V
5 Marks Questions	A	1	2	2	2	1
10 Marks Questions	B	1	2	2	1	2
Weightage		15	30	30	20	25

- Note:**
1. please provide the scheme of valuation for the paper.
 2. Question paper should be both in English and Telugu media.

A.G. & S.G.SIDDHARTHA DEGREE COLLEGE OF ARTS & SCIENCE, VUYYURU-521165,
KRISHNA Dt.,A.P. (AUTONOMOUS)
AQUACULTURE
PRACTICAL – III

w.e.f. 2021-2022.
Code: AQU- 301P
(2hrs/week)

MAX.MARKS: 50.

PRACTICAL SYLLABUS

1. Identification of important cultivable carps.
2. Identification of important cultivable air-breathing fishes.
3. Identification of important cultivable fresh water prawns.
4. Identification of different life history stages of fish.
5. Identification of different life history stages of fresh water prawn Collection and study of weed fish.
6. Identification of commercially viable crabs – Scylla cerrata, Portunus pelagicus, P.sanguinolentus, Neptunus pelagicus, N. Sanguinolentus .
7. Identification of lobsters – Panulirus polyphagus, P.ornatus, P.homarus, P.sewelli, P.penicillatus.
8. Identification of oysters of nutritional significance – Crossostrea madrasensis, C.gryphoides C. cucullata, C.rivularis , Picnodanta .
9. Identification of mussels and clams.
10. Identification of developmental stages of oysters.
- 11 .Field visit to aqua farm and study of different components like dykes etc.

PRESCRIBED BOOK(S):

1 Jhingran VG 1998. Fish and Fisheries of India. Hindusthan Publishing Corporation, New Delhi

REFERENCES:

1. Santharam R, N Sukumaran and P Natarajan 1987. A manual of aquaculture, Oxford-IBH, New Delhi .
2. Srivatsava 1993. Fresh water aquaculture in India, Oxford-IBH, New Delhi Marcel H 1972. Text book of fish culture.Oxford fishing news books.

Practical - III

w.e.f. 2021 - 2022

Model Question Paper (External)

Max. Marks: 25
Paper Code: AQU-301P

1. Identify, draw labeled diagram & write notes on important cultivable carps. 2x2=4
A & B
2. Identify, draw labeled diagram & write notes on air-breathing fishes. 2x2=4
A & B
3. Identify, draw labeled diagram & write notes on important cultivable fresh water prawns. 2x2=4
A&B
4. Identification of commercially viable crabs 2x2=4
A & B
5. Identify, draw labeled diagram & write notes on A, B, C 3x2=6
- 6 Identification of developmental stages of oysters 3

Total-----25m

Guide lines for the practical Examiners

1. ½ Mark for identification, ½ Mark for labeled diagram & 1 Mark for notes for each question.
(2 specimens / slides / models.)
2. ½ Mark for identification, ½ Mark for labeled diagram & 1 Mark for notes for each question.
(2 specimens / slides / models.)
3. ½ Mark for identification, ½ Mark for labeled diagram & 1 Mark for notes for each question.
(2 specimens / slides / models.)
4. ½ Mark for identification, ½ Mark for labeled diagram & 1 Mark for notes for each question.
(2 specimens / slides / models.)
5. ½ Mark for identification, ½ Mark for labeled diagram & 2 Mark for notes for each question.
(3 specimens / slides / models.)
6. Labeled diagrams 1 mark & 2 marks for notes (3marks)

INTERNAL PRACTICAL- III

Practical –III Code: AQU-301P. MODEL QUESTION PAPER -III

Max.marks:25M.

Time: 3hrs.

1. Attendance ----- 05M.
2. Record ----- 10M.
3. Field note book. ----- 05M
4. Assignment ----- 05M.

Total ----- 25M.

**USUMILLI GOPALAKRISHNAIAH & SUGAR CANE GROWERS SIDDHARTHA
DEGREE COLLEGE OF ARTS & SCIENCE, VUYYURU-521165, KRISHNA Dt., A.P.
(AUTONOMOUS).**

NACC reaccredited at 'A' level
Autonomous –ISO 9001-2015 Certified

Title of the Paper: **Fish health management**

Semester: - V

Course Code	<i>AQU-501C</i>	Course Delivery Method	Class Room/Blended Mode - Both
Credits	3	CIA Marks	30
No. of Lecture Hours/ Week	4	Semester End Exam Marks	70
Total Number of Lecture Hours	60	Total Marks	100
Year of Introduction : 2021-2022	Year of Offering 2021-2022	Year of Revision –	Percentage of Revision:

Objective of the course: The students understand Fresh health management and Diseases of fishes.

Course outcomes:

CO1: Provide students with knowledge about fish diseases and pathological aspects of diseases.

CO2: Learn about Fungal, Viral and Bacterial diseases of finfish.

CO3: Learn about major shrimp viral, bacterial and protozoan diseases and prevention and therapy methods.

CO4: Gain knowledge of Nutritional deficiency related diseases and antibiotic and chemotherapeutics.

CO5: Understand and learn the importance of diagnostic tools in identification of diseases and

application and development of vaccines. To know about production of disease free seeds and good feed management.

Learning Objectives:

- To understand the principles of disease diagnosis and fish health management.
- To know the prophylactic and therapeutic methods to control the diseases.
- To understand the defence mechanism and immune system in fish and shrimp.
- To gain detailed knowledge on the disease symptoms, causative agent, preventive measures and treatment for microbial, parasitic, nutritional and environmental disorders in fish and shrimp.
- To understand the diagnosis tools that is followed in field of aquaculture and vaccine production for fish immunization.

Syllabus
Course Details

Unit	Learning Units	Lecture Hours
I	<p>UNIT I: Pathology and parasitology Introduction to fish diseases –Definition and categories of diseases – Disease and environment Disturbance in cell structure – changes in cell metabolism, progressive and retrogressive tissue changes, types of degeneration, infiltration, necrosis, cell death and causes Atrophy, hypertrophy, neoplasms, inflammation, healing and repair</p>	10
II	<p>UNIT II: Diseases of fin fish. Fungal diseases (both of shell and finfish) – Saprolegniosis, brachiomyxosis, ichthyophthiriosis diseases – Lagenidium diseases – Fusarium disease, prevention and therapy Viral diseases – Emerging viral diseases in fish, haemorrhagic septicemia, spring viremia of carps, infectious hematopoietic necrosis in trout, infectious pancreatic necrosis in salmonids, swim-bladder inflammation in cyprinids, channel cat fish viral disease, prevention and therapy Bacterial diseases – Emerging bacterial diseases, aeromonas, pseudomonas and vibrio infections, columnaris, furunculosis, epizootic ulcerative syndrome, infectious abdominal dropsy, bacterial gill disease, enteric red mouth, bacterial kidney disease, proliferative kidney disease, prevention and therapy</p>	15
III	<p>UNIT III: Diseases of shell fish Major shrimp viral diseases – Baculovirus penaei, Monodon Baculovirus, Baculoviral midgut necrosis, Infectious hypodermal and hematopoietic necrosis virus, Hepatopancreatic parvo like virus, Yellow head baculovirus, white spot baculovirus. Bacterial diseases of shell fish – aeromonas, pseudomonas and vibrio infections, luminous bacterial disease, filamentous bacterial disease. Prevention and therapy Protozoan diseases- Ichthyophthiriasis, Costiasis, whirling diseases, trypanosomiasis Prevention and therapy</p>	12
IV	<p>UNIT IV: Nutritional diseases Nutritional pathology – lipid liver degeneration, Vitamin and mineral deficiency diseases. Aflatoxin and dinoflagellates. Antibiotic and chemotherapeutics. Nutritional cataract. Genetically and environmentally induced diseases</p>	8
V	<p>UNIT V: Fish health management Diagnostic tools – immune detection- DNA/RNA techniques, General preventive methods and prophylaxis. Application and development of vaccines. Quarantine – Significance, methods and regulations for transplants. Production of disease-free seeds. Evaluation criteria of healthy seeds. Good Feed management for healthy organisms, Zero water exchange, Probiotics in health management, Issues of bio security.</p>	15

**A.G. & S.G.Siddhartha Degree College of Arts & Science, Vuyuru – 521165,
Krishna Dt. A.P. (Autonomous)**

Semester –V

Model question paper

Title of the paper: Fish health management.

Time: 3hrs.

w.e.f. 2021-2022

Code – AQU-501

Max.marks: 70

4 x 5= 20.

Section – A

Answer any **four** questions. Each question carries **five** marks. Draw neat labelled diagrams wherever necessary.

1. Necrosis.
2. Atrophy
3. Lagenidium diseases
- 4 Bacterial kidney diseases.
5. Monodon Baculovirus
6. Yellow head baculovirus
7. Lipid liver degeneration
- 8, Zero water exchange.

Section – B

5 x 10 =50.

Answer any **five** questions. Each question carries **Ten** marks.

Draw neat labelled diagrams wherever necessary.

9. Write an essay on any two nutritional Requirements for cultivable fish?
10. Explain the changes in cell metabolism?
11. Explain about Bacterial diseases of shell fish?
12. Explain about channel cat fish viral disease prevention and therapy?
13. Describe the Protozoan diseases??
14. Write an essay on genetically and environmentally induced diseases?
15. Explain about application and development of vaccines?
16. Methods and regulations for transplants?

**A.G. & S.G.Siddhartha Degree College of Arts & Science, Vuyyuru – 521165,
Krishna Dt. A.P. (Autonomous)**

Semester - V

Guide lines to the Paper Setter

W.e.f. 2021-2022

Title of the paper: Fish health management

Code – AQU-501C

Time: 3hrs.

Max. Marks: 70.

1. Answer any **four** questions out of eight in Section – A. Each question carries five marks.
4x5 = 20M.

2. Answer any **five** questions out of eight in Section – B. Each question carries Ten marks.
5x10= 50M.

	Section	UNIT-I	UNIT-II	UNIT-III	UNIT-IV	UNIT-V
5 Marks Questions	A	2	2	2	1	1
10 Marks Questions	B	1	2	2	1	2
Weightage		20	30	20	20	25

Note: 1. please provide the scheme of valuation for the paper.

2. Question paper should be in English medium.

A.G. & S.G.SIDDHARTHA DEGREE COLLEGE OF ARTS & SCIENCE, VUYYURU-
521165, KRISHNA Dt.,A.P. (AUTONOMOUS)

AQUACULTURE
PRACTICAL -V

w.e.f. 2021-2022.
MAX.MARKS: 50.
(2hrs/week)

Code: AQU- 501P

PRACTICAL SYLLABUS

-
1. Enumeration of Bacteria by TPC Method
 2. Enumeration of total Coli forms
 3. Observation of gross pathology and external lesions of fish and prawn with reference to the common diseases in aquaculture
 4. Examination of pathological changes in gills and gut lumen, lymphoid organ, muscles and nerves of fish
 5. Examination of pathological changes in gut lumen, hepatopncreas, lymphoid organ, muscles and nerves of prawn and shrimp
 6. Collection, processing and analysis of data for epidemiological investigations of viraldiseases
 7. Bacterial pathogens – isolation, culture and characterization
 8. Identification of parasites in fishes: Protozoan, Helmiths, Crustaceans
 9. Antibio grams – preparation and evaluation
 10. Molecular and immunological techniques; Biochemical tests; PCR; ELISA; Agglutination test; Challenge tests; Purification of virus for development of vaccines (Demonstration at institutes/labs)
 11. Estimation of dose, calculation of concentration, methods of administration of various chemotherapeutics to fish and shell fish
 12. Estimation of antibiotics used in aquaculture practices
 13. Estimation of probiotics used in aquaculture
 14. Field visit to farm for health monitoring and disease diagnosis

PRESCRIBED BOOK(S):

1. Shaperclaus W. 1991 Fish Diseases- Vol.I & II. Oxonian Press Pvt.ltd
2. Roberts RJ 1989. Fish pathology. Bailliere Tindall, New York
3. Lydia Brown 1993. Aquaculture for veterinarians- fish husbandry and medicine. Pergamon Press. Oxford

REFERENCES:

1. Shankar KM & Mohan CV. 2002. Fish and Shellfish Health Management. UNESCO Publ. Sindermann CJ. 1990
2. Walker P & Subasinghe RP. (Eds.). 2005 Principal Diseases of Marine Fish and Shellfish. Vols. I, II. 2nd Ed. Academic Press
3. DNA Based Molecular Diagnostic Techniques: Research Needs for Standardization and Validation of the Detection of Aquatic Animal Pathogens and Diseases. FAO Publ. Wedmeyer G, Meyer FP & Smith L. 1999.
4. Bullock G et.al., 1972 Bacterial diseases of fishes. TFH publications, New Jersey

A. G.& S.G. SIDDHARTHA DEGREE COLLEGE OF ARTS & SCIENCE, VUYYURU

EXTERNAL PRACTICAL- V

MODEL QUESTION PAPER –V

**w.e.f. 2021-2022.
Code: AQU-501P**

Time: 3 hrs.

Max.marks: 25m.

I.Estimation of antibiotics used in aquaculture practices	5M.
II. Biochemical tests	5M.
III.ELISA	:5M
IV. Identify, draw labelled diagram & write notes on A, B, C, D ,E	5X2=10

TOTAL: ----- 25M.

Guide lines for the practical Examiners

I:Estimation of carbohydrate content in aquaculture feeds (4 marks notes & Result 1 mark.)

II:Biochemical tests. (5 marks notes)

III:ELISA (5 marks notes)

IV. ½ Mark for identification, ½ Mark for labeled diagram & 2 Mark for notes for each question.

4 specimens / slides / models.

**A. G.& S.G. SIDDHARTHA DEGREE COLLEGE OF ARTS & SCIENCE,
VUYYURU-521165**

INTERNAL PRACTICAL-V

w.e.f. 2021-2022.

Code: AQU-501P

MODEL QUESTION PAPER -V

Max.marks:25M.

Time: 3hrs.

1. Attendance	-----	05M.
2. Record	-----	10M.
3. Field trip	-----	10M

Total ----- 25M.

**ADUSUMILLI GOPALAKRISHNAIAH & SUGAR CANE GROWERS SIDDHARTHA
DEGREE COLLEGE OF ARTS & SCIENCE, VUYYURU-521165, KRISHNA Dt., A.P.
(AUTONOMOUS).**

NACC reaccredited at 'A' level
Autonomous –ISO 9001-2015 Certified

Title of the Paper: **Extension, Economics & Marketing**

Semester: - V

Course Code	AQU-502C	Course Delivery Method	Class Room/Blended Mode - Both
Credits	3	CIA Marks	30
No. of Lecture Hours/ Week	4	Semester End Exam Marks	70
Total Number of Lecture Hours	60	Total Marks	100
Year of Introduction : 2021-2022	Year of Offering 2021-2022	Year of Revision –	Percentage of Revision:

Objective of the course: The students understand Extension, Economics & Marketing aspect of fisheries and aquaculture and help the students in applying their theoretical knowledge into practical in order to be self reliance and to be a good pace setters in the business world.

Course outcomes:

CO1: Gain the Knowledge of basic concepts of economics with reference to fisheries and various factors influencing the fishery products price.

CO2: Will come to know about fisheries marketing, methods of economic analysis of business organizations and preparation of project and project appraisal.

CO3: To know about application of economic principles to aquaculture operations.

CO4: Get the broad knowledge of scope and objectives, principles of fisheries extension.

CO5: Understand the importance of transfer technology of ICAR programmes and training at DAATTCentres and their role in education of aqua farmers through print and electronic media.

Learning Objectives:

- To explain fisheries economics and marketing.
- To understand economics constraints in fisheries development, free access to fisheries, sustainable yield curve and total revenue curve, bio economic equilibrium, factor rents welfare economic theory and its relevance for fisheries externalities.
- To understand fisheries extension methods and rural development
- Write Feasibility report

Syllabus
Course Details

Unit	Learning Units	Lecture Hours
I	<p>UNIT – I Introduction Meaning and scope of economics with reference to fisheries Basic concepts of economics – goods, services, wants and utility, demand and supply, value price, market demand and individual demand, elasticity of demand, law of diminishing marginal utility Theory of production, production function in fisheries Various factors influencing the fishery product's price.</p>	10
II	<p>UNIT – II Fisheries marketing Basic marketing functions, consumer behavior and demand, fishery market survey and test marketing a product Fish marketing – prices and price determination of fishes Marketing institutions- primary (producer fishermen, fishermen cooperatives, and fisheries corporations) and secondary (merchant/agent/speculative middlemen) Methods of economic analysis of business organizations Preparation of project and project appraisal</p>	15
III	<p>UNIT-III Fisheries economics Aquaculture economics- application of economics principles to aquaculture operations Various inputs and production function. Assumptions of production function in aquaculture analysis, least cost combination of inputs, laws of variable proportions 3 Cost and earnings of aquaculture systems – carp culture, shrimp farming systems, hatcheries, Cost and earnings of fishing units and freezing plants Socio-economic conditions of fishermen in Andhra Pradesh, Role of Matsyafed and NABARD in uplifting fishermen's conditions, fishermen cooperatives Contribution of fisheries to the national economy</p>	15
IV	<p>UNIT-IV Fisheries extension Fisheries extension – scope and objectives, principles and features of fisheries extension education Fisheries extension methods and rural development Adoption and diffusion of innovations</p>	10
V	<p>UNIT-V Transfer of technology ICAR programs – salient features of ORP, NDS, LLP, IRDP, ITDA, KVK, FFDA, FCS, FTI, TRYSEM Training – meaning, training vs. education and teaching DAATT centers and their role in tot programs, video conferencing, education of farmer through print and electronic media.</p>	15

**A.G. & S.G.Siddhartha Degree College of Arts & Science, Vuyyuru – 521165,
Krishna Dt. A.P. (Autonomous)**

Semester –V

w.e.f. 2021-2022

Model question paper

Title of the paper:Extension, Economics & Marketing

Code – AQU-502C

Time: 3hrs.

Max.marks: 70

Section – A

4 x 5= 20.

Answer any **four** questions. Each question carries **five** marks. Draw neat labelled diagrams wherever necessary.

1. Demand and supply.
2. Goods
3. Consumer behaviour
- 4.Preparation of project
5. NABARD
- 6.Scope and objectives
7. IRDP
8. Salient features of ORP

Section – B

5 x 10 =50.

Answer any **five** questions. Each question carries **Ten** marks. Draw neat labelled diagrams wherever necessary.

9. Write an essay on any two nutritional Requirements for cultivable fish?
- 10.Explainthemarket demand and individual demand?
- 11.Explain aboutproduction function in fisheries?
12. Give an account of Marketing institutions?
- 13.Methods of economic analysis of business organizations?
14. Write an essay onshrimp farming systems?
- 15.Explain aboutFisheries extension methods and rural development?
- 16.DAATT centers and their role in tot programs?

**A.G. & S.G.Siddhartha Degree College of Arts & Science, Vuyyuru – 521165,
Krishna Dt. A.P. (Autonomous)**

Semester - V

Guide lines to the Paper Setter.

W.e.f. 2021-2022

Title of the paper: Extension, Economics & Marketing

Code – AQU-502C

Time: 3hrs.

Max. Marks: 70.

1. Answer any **four** questions out of eight in Section – A.

Each question carries five marks. $4 \times 5 = 20M$.

2. Answer any **five** questions out of eight in Section – B

Each question carries Ten marks. $5 \times 10 = 50M$.

	Section	UNIT-I	UNIT-II	UNIT-III	UNIT-IV	UNIT-V
5 Marks Questions	A	2	2	1	1	2
10 Marks Questions	B	2	2	2	1	1
Weightage		30	30	25	20	25

Note: 1. please provide the scheme of valuation for the paper.

2. Question paper should be in English medium.

A.G. & S.G.SIDDHARTHA DEGREE COLLEGE OF ARTS & SCIENCE, VUYYURU-
521165, KRISHNA Dt.,A.P. (AUTONOMOUS)

AQUACULTURE
PRACTICAL -VI

w.e.f. 2021-2022.

Code :AQU- 502P
MAX.MARKS : 50.
(2hrs/week)

PRACTICAL SYLLABUS

PRACTICAL:

Project work/on-job training at industry.

PRESCRIBED BOOK(S):

1. Adivi Reddy sv 1997. An introduction to extension education. Oxford & IBH Co.Pvt. Ltd. New Delhi
2. Jayaraman R 1996. Fisheries Economics. Tamilnadu Veterinary and Animal Science University. Tuticorn
3. Subba Rao N 1986. Economics of Fisheries. Daya publishing house, Delhi

REFERENCES:

1. Dewwett KK and Varma JD 1993. Elementary economic theory. S.chand, New Delhi
2. Korakandy R 1996. Economics of Fisheries Mangement. Daya Publishing House, Delhi
3. Tripathi SD 1992. Aquaculture Economics. Asian Fisheries Society, Mangalore.

A.G&S.G.SIDDHARTHA DEGREE COLLEGE OF ARTS & SCIENCE
VUYYURU-521165, KRISHNA Dt., A.P.

An Autonomous College in the Jurisdiction of Krishna University, Machilipatnam
Accredited by NAAC with “A” Grade ISO9001-2015 Certified Institution

2021-2022

B.SC.AQUACULTURE(Industrial Fisheries)

EVEN SEMESTER



DEPARTMENT OF ZOOLOGY

MINUTES OF BOARD OF STUDIES

B.SC.AQUACULTURE

01-04-2022







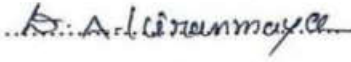

Minutes of the meeting of Board of studies in Zoology for the Autonomous courses of AG & SG Siddhartha Degree College of Arts & Science, Vuyyuru, held at 2:30 pm on 01.04,2022 in the Department of Zoology.

Smt.D.A. Kiranmayee. ...

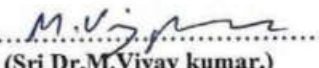
Presiding

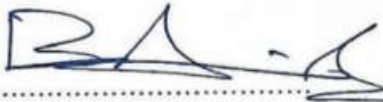
Members Present:

- 1)  Chair person Head, Department of Zoology,
(Smt. D.A.Kiranmayee.) A.G&S.G.S Degree College of
Vuyyuru-521165.
- 2)  University Nominee Bio Sciences & Bio technology
(Smt. Dr.L.Suseela.) Krishna University
Machilipatnam.
- 3)  Academic Council Head,Department of Zoology,
(Sri Dr.M.Viyay kumar.) Nominee SRR & CVR Govt. Degree College,
Vijayawada.
- 4)  Academic Council Head, Department of Zoology,
(Sri Ch. Venkateswaralu.) Nomine P.B. Siddhartha College,
Vijayawada.
- 5)  Member Lecturer in Zoology,
(Smt. K. Padmaja.) A.G&S.G.S Degree College
Vuyyuru-521165.
- 6)  Industrialist Asst. Project Manager,
(B. Appala Naidu.) RGCA
Manikonda.
- 7)  Student Represent P.hd –Research Scholar,
(Ch.Chiranjeevi) Dept.of Botany & Microbiology,
Acharya Nagarjuna University,
Guntur.

Agenda for B.O.S Meeting.

1. To recommend the syllabi (Theory & Practical), Model question paper for II Semester of I B.Sc (A.B.C) for the academic year 2021-2022.
2. To recommend the syllabi (Theory & Practical), Model question paper for IV Semester of II B.Sc (A.B.C) for the academic year 2021-2022.
3. To discuss to the syllabus of Elective & Clusters in VI semester for the academic year 2021-2022.
4. To recommend the Model question paper for VI Semester of III B.Sc (A.B.C) for the academic year 2021-2022.
5. To recommend Model question paper and Blue print of II, IV & VI semester of I, II, III B.Sc (A.B.C.) for the academic year 2021-2022.
6. To recommend the teaching and evaluation methods to be followed under Autonomous status.
7. Any other matter.



Chairman.

RESOLUTIONS

1. It is resolved to continue the same syllabi (Theory & Practical), model question paper of II Semester of I B.Sc. (A.B.C) under Choice Based Credit System (CBCS) for the academic Year 2021 – 2022.
2. It is resolved to follow the changed syllabi (Theory & Practical), model question paper of IV Semester of II B.Sc. (A.B.C) under Choice Based Credit System (CBCS) for the academic Year 2021 – 2022.
3. It is resolved to follow Elective (Ornamental Fishery) and Cluster I. Fish Processing Technology, Cluster-II . Fishery Microbiology and Fishery by- Products & Cluster- III. Quality Control in Processing plants in VI Semester from the Academic year 2021-2022
4. It is resolved to follow the suggested model question paper for VI Semester of III B.Sc. (A.B.C) under Choice Based Credit System (CBCS) for the academic Year 2021 – 2022.
5. It is resolved to follow the Model question paper and Blue print as suggested for II & IV semester of I, II B.Sc (A.B.C.) for the academic year 2021-2022.
6. It is resolved to continue the following teaching & evaluation methods for the Academic year 2021-22.
7. Any other matter.

Teaching methods:

Besides the conventional methods of teaching, we use modern technology i.e. Using of OHP and LCD projector to display on U boards etc; for better understanding of concepts.

Evaluation of a student is done by the following procedure:

Internal Assessment Examination:

- Out of maximum 100 marks in each paper for II & III B.Sc(A.B.C) 30 marks shall be allocated for internal assessment.
- Out of these 30 marks, 20 marks are allocated for announced tests (i.e . IA-1& IA-2). Two announced tests will be conducted and average of these two tests shall be deemed as the marks obtained by the student, 5 marks are allocated on the basis of candidate's percentage of attendance and remaining 5 marks are allocated for the assignment for I,II& III B.Sc (A.B.C).
- Out of maximum 100 marks in each paper for I B.Sc(A.B.C) 25 marks shall be allocated for internal assessment.
- Out of these 25 marks, 15 marks are allocated for announced tests (i.e . IA-1& IA-2). Two announced tests will be conducted and average of these two tests shall be deemed as the marks obtained by the student, 5 marks are allocated on the basis of candidate's percentage of attendance / assignment for II, semester.
- There is no pass minimum for internal assessment for I, II, III B.Sc

Semester – End Examination:

- The maximum mark for I (ABC) semester – End examination shall be 75 marks and duration of the examination shall be 3 hours.
- The maximum mark for IV, VI (A.B.C) semester – End examination shall be 70 marks and duration of the examination shall be 3 hours. Even though the candidate is absent for two IA exams/ obtain Zero marks the external marks are considered (if the candidate gets 40/70) and the result shall be declared as “PASS”.
- Semester – End examination shall be conducted in theory papers at the end of every semester, while in practical papers, these examinations are conducted at the end of II, IV & VI semester for I, II & III B.Sc, (A.B.C).



Chairman

ADUSUMILLI GOPALAKRISHNAIAH & SUGAR CANE GROWERS SIDDHARTHA DEGREE COLLEGE OF ARTS & SCIENCE, VUYYURU-521165, KRISHNA Dt., A.P. (AUTONOMOUS).

NAAC reaccredited at 'A' level
Autonomous –ISO 9001-2015 Certified

Title of the Paper: BIOLOGY OF FIN FISH & SHELL FISH.

Semester: - II

Course Code	AQTT21A	Course Delivery Method	Class Room/Blended Mode - Both
Credits	3	CIA Marks	25
No. of Lecture Hours/ Week	4	Semester End Exam Marks	75
Total Number of Lecture Hours	60	Total Marks	100
Year of Introduction : 2019-20	Year of Offering 2019-20	Year of Revision –	Percentage of Revision:

AIM

- To know the biology of fin fish and shell fish.

OBJECTIVES

- To study the systematics of cultivable finfish and shellfish.
- To understand feeding habit and growth patterns of cultured species.
- To study the factors responsible for longevity of fishes.
- To study the reproductive biology of finfish and shell fish.
- To study the developmental aspects of cultivable finfish and shell fish.
- To study the role of hormones in the growth of finfish and shell fish.

PREREQUISITE

- Knowledge of fisheries management acquired in Intermediate.

COURSE OUTCOMES

By the end of the course students will be able to

CO 1	Classify the finfish and shellfish, analyse the cultivable species of fin fish and shellfish of commercial importance, describe their salient features and appreciate the diversity and uniqueness of different groups.
CO 2	Comprehend the relationship between food and growth, age and growth, hormones and growth in cultivable fin and shell fish.
CO 3	Gain knowledge and compare the feeding habits, mouth parts and digestive systems and analyze gut contents.
CO 4	Develop the skill of identifying the gut contents, gonadal maturity and fecundity and comprehend the concept of breeding behaviour, embryonic and larval development of cultivable aquatic fin and shell fish.
CO 5	Acquaint with the significance of unique mechanisms and behavioural patterns like sense organs, electric organs, buoyancy, moulting and metamorphosis exhibited by finfish and shell fish.

Syllabus :

Unit	Learning Units	Lecture Hours
I	<p>1.0. Introduction Classification of Finfish and Shell fish Classification of fishes up to the level of Class. Classification of crustaceans up to the level of Class Finfish and Shell fish of Commercial Importance Cultivable fin fish Cultivable shell fish Sense organs of fishes and crustaceans</p>	11
II	<p>2.1. Food, Feeding and Growth Natural fish food Feeding habits, feeding intensity, stimuli for feeding, utilization of food Gut content analysis. Structural modifications in relation to feeding habits. Forage ratio and food selectivity index 2.2. Age and Growth Principles of Age and growth determination Growth regulation Growth rate measurement – scale method, otolith method, skeletal parts as age indicators Genetic, biotic & ecological factors in determining the longevity of fishes Length frequency method, age composition, age-length keys, absolute and specific growth, back calculation of length and growth, annual survival rate, asymptomatic length, fitting of growth curve . Length-weight relationship Condition factor/Ponderal index, relative condition factor</p>	17
III	<p>3.0. Reproductive Biology Breeding in Fishes .Breeding habits & breeding grounds Breeding in natural environment and in artificial ponds, courtship Reproductive cycles Induced breeding in fishes Breeding in shrimp Breeding in pearl oyster</p>	9
IV	<p>4.0. Development Ovo-viviparity, oviparity, viviparity in fishes Parental care in fishes, nest building and brooding Embryonic and larval development of fishes Embryonic and larval development of shrimp 4.. Embryonic and larval development of crabs Environmental factors affecting reproduction and development of cultivable aquatic fin & shellfish</p>	12
V	<p>5.0. Hormones & Growth Endocrine system in fishes Neurosecretory cells, androgenic gland, ovary, Y-organ, chromatophores, Pericardial glands and cuticle. Molting, molting stages, metamorphosis in crustacean shellfish</p>	11

PRESCRIBED BOOK(S):

1. Bone Q et al., 1995. Biology of fishes, Blackie academ
2. ic &professional,LONDON
3. Saxena AB 1996. Life of Crustaceans.Anmol Publications Pvt. Ltd., New Delhi

REFERENCES:

- 1.Tandon K.K&Johal M.S 1996.Age and Growth in Indian Fresh Water Fishes.Narendra Publishing
2. Raymond T et al., 1990. Crustacean Sexual Biology, Columbia University Press, New York
3. Guiland J.A (ed) 1984. Penaeid shrimps- Their Biology andManagement.
4. Barrington FJW 1971. Invertebrates: Structure andFunction. ELBS
5. Parker F &Haswell 1992. The text book of Zoology, Vol I.Invertebrates

CO-CURRICULAR ACTIVITIES

1. Collection of cultivable finfish and shellfish
2. Animal album-making on cultivable finfish and shellfish
3. Preparation of models of digestive system of herbivorous, omnivorous and carnivorous fishes.
4. Preparation of charts on sense organs of fish and crustaceans
5. Growth rate measurement of different fishes using various methods.
6. Collection of data and finding the length –weight relationship in fishes.
7. Preparation of charts on reproductive cycles in fishes.
8. Preparation of models on fish nests.

**A.G& S.G.S.DEGREE COLLEGE OF ARTS & SCIENCE, VUYYURU – 521165, KRISHNA
Dt.,A.P. (AUTONOMOUS)
SEMESTER-II**

(Model Question paper)

w.e.f. 2019 – 2020

Paper Title: **BIOLOGY OF FIN FISH & SHELL FISH.**

Paper Code: AQT21

Time: 3 hrs

Max.Marks:75

Note: Draw neat labelled Diagrams wherever necessary.

SECTION-A

Answer any **Five** of the following Questions. **5X5= 25M**

1. Evaluate the significance of Exotic fishes in culture.CO1, L4
2. Explain the structure and function of Sense organs in fishes. CO5, L2
3. Explain the different fish feeding habits. –CO2, L5
4. Describe Condition factor and Relative condition factor.–CO2, L2
5. Describe breeding process in Pearl oyster.– CO4, L2
6. Explain Ovo-viviparity in Fishes. CO4, L2
7. Explain the Embryonic and larval Development in Crabs.CO2, L5
8. Write a short note on Neurosecretary cells. – CO3, L1

SECTION-B

Answer **all** the Questions.**5X10=50M**

9. Classify the Crustaceans up to the level of subclass. CO1, L2
(Or)
Give an account of Buoyancy in fishes .– CO5, L2
10. Explain different factors that determine the longevity of fishes. – CO2, L4
(Or)
Describe the different methods of estimating age and growth of fish. – CO2, L4
11. Describe the process of Induced breeding in Fishes. CO2, L2
(Or)
Explain the breeding technique in shrimp. CO2, L2
12. Explain the role of Environmental factors on reproduction and development of finfish. CO2, L2
(Or)
Write an essay on Embryonic and larval development in shrimp. CO2, L2
13. Describe the structure of Pituitary gland and explain the functions of its hormones. CO2, L2
(Or)
Describe the process of Moulting in Crustaceans.CO2, L2

AQUACULTURE
PRACTICAL -II

Semester- II

Max. Marks: 50

Title Of The Paper:-Biology Of Fin Fish & Shell Fish

NO OF HOURS: 30

CREDITS: 02

LEARNING OUTCOMES:

By the end of the course students will be able to

- Differentiate between the feeding habits of different fish and shell fish basing on their mouth parts and alimentary canal and identify the various appendages of shellfish.
- Understand the length – weight relationship and analyse the gut contents of fish and shrimp.
- Identify the eggs and larval stages of different cultured species of fish and shell fish and confirm the maturity and fecundity in fish and shell fish.
- Gain knowledge in nest building and brooding in fishes.
- Maintain a neat, labeled record of identified museum specimens and exhibit the hidden creative talent.

1. Study of mouth parts in herbivorous omnivorous and carnivorous fishes
2. Comparative study of digestive system of herbivorous and carnivorous fishes
3. Length-weight relationship of fishes
4. Gut content analysis in fishes and shrimp
5. Mouth parts and appendages of cultivable prawns, shrimps and other crustaceans
6. Study of eggs of fishes, shrimps, prawns and other crustaceans
7. Study of gonadal maturity and fecundity in fishes and shellfish
8. Observation of crustacean larvae
9. Study of nest building and brooding of fishes
10. Biostatistics – Mean, Mode, Median, Standard Deviation, Correlation and t-test

REFERENCES

1. Bone Q et al., 1995. Biology of fishes, Blackie academic & professional, LONDON
2. Saxena AB 1996. Life of Crustaceans. Anmol Publications Pvt.Ltd., New Delhi
3. Tandon K.K & Johal M.S 1996. Age and Growth in Indian Fresh Water Fishes. Narendra Publishing
4. Raymond T et al., 1990. Crustacean Sexual Biology, Columbia University Press, New York
5. Guiland J.A (ed) 1984. Penaeid shrimps- Their Biology
6. **Thomas PC, Rath SC & Mohapatra KD.** 2003. Breeding and Seed Production of Finfish and Shellfish. Daya Publ.

Chakraborty C & Sadhu AK. 2000. Biology Hatchery and Culture Technology of Tiger Prawn and Giant Freshwater Prawn. Daya Publ. House

AQUACULTURE

BIOLOGY OF FIN FISH AND SHELL FISH

MODEL QUESTION PAPER

EXTERNAL PARTICAL PAPER- II

SEMESTER-II

Time: 3 Hours

COURSE CODE: AQT P21

Max. Marks: 40M

1. Identify and draw labeled diagram of digestive system of Labeorohita.

Compare it with that of a carnivorous fish. CO1, L2 &L3

10M

Or

Identify and draw labeled diagram of digestive system of Channapunctatus.

Compare it with that of a herbivore fish. CO1, L2 &L3

Identification: 1M

Diagram: 2M

Labelling: 3M

Comparison: 4M

2. Identify and draw labeled diagram of abdominal appendages of Macrobrachiummalcolmsonii. CO1, L3

10M

Or

Identify and draw labelled diagram of thoracic appendages of Scylla serrata.CO1, L3

Identification: 2M

Diagram: 4M

Labelling: 4M

3. Identify and comment on CO1, CO3 & CO4, L3 & L1

4x2½ =10M

A. Mouth parts of fish/prawn/crab

B. Egg mass of fish/prawn/shrimp/crab

C. Crustacean larvae

D. Types of fish nests

Identification: 1M

Diagram: ½M

Notes: 1M

4. Record Book CO5, L3

5M

5.VIVA CO5, L5

5M

INTERNAL PRACTICAL- II

Max.marks: 10M.

1. Attendance ----- 05M.

2. Assignment ----- 05M.

Total ----- 10 M.

**ADUSUMILLI GOPALAKRISHNAIAH & SUGAR CANE GROWERS SIDDHARTHA DEGREE
COLLEGE OF ARTS & SCIENCE, VUYURU-521165, KRISHNA Dt., A.P. (AUTONOMOUS).**

NAAC reaccredited at 'A' level
Autonomous –ISO 9001-2015 Certified

Title of the Paper: **FISH NUTRITION & FEED TECHNOLOGY**

Semester: - IV

Course Code	<i>AQU-401</i>	Course Delivery Method	Class Room/Blended Mode - Both
Credits	3	CIA Marks	30
No. of Lecture Hours/ Week	4	Semester End Exam Marks	70
Total Number of Lecture Hours	60	Total Marks	100
Year of Introduction : 2021-2022	Year of Offering 2021-2022	Year of Revision –	Percentage of Revision:

Learning Objectives:

- 1 To know the nutritional requirements of fish and shell fish at different stages of their life.
- 2 To understand the different types of feeds, and feed additives used in the preparation of fish and shell fish feeds.
- 3 To improve the knowledge on feed manufacture and feed storage.
- 4 To gain knowledge on feeding and feed evaluation methods.
- 5 To gain knowledge on feed manufacture and storage -
- 6 To know the nutritional pathology and remedial methods of cultivable fish and shrimp.
- 7 To improve the technical knowledge feed quality and nutritional value analysis.

Course outcomes:

CO 1	Understand Nutritional requirements of cultivable fishes and factors affecting energy partitioning and feeding.
CO 2	Know different types of feed and FCR and different types of feeders
CO 3	Gain Knowledge of Feed manufacture and storage methods of feeds
CO 4	Understand the value of Feed additives and Non-Nutrient ingredients
CO 5	To create awareness of different nutritional deficiency and importance of natural and supplementary feeds and balanced diet.

**Syllabus
Course Details**

Unit	Learning Units	Lecture Hours
I	<p>Nutritional requirements of cultivable fish and shellfish Classification of nutrients; Nutritional requirements (energy, proteins, carbohydrates, lipids, fiber, micronutrients) of different stages of cultivable fish and shellfish. Essential amino acids and fatty acids, protein to energy ratio, nutrient interactions and protein sparing effect Dietary sources of energy, effect of ration on growth, determination of feeding rate, check tray, factors affecting energy partitioning and feeding Importance of natural and supplementary feeds, balanced diet.</p>	10
II	<p>Types of feeds and Feed additives Live foods: Fish food organisms – Bacterioplankton, phytoplankton, zooplankton and their role in larval nutrition. Artificial feeds: Supplementary feed stuffs; Non-conventional feed ingredients; Forms of processed feeds - wet feeds, moist feeds, dry feeds, mashes, pelleted feeds - floating and sinking pellets; advantages of pelletization Water stability feeds, farm made aqua feeds, micro-coated feeds, micro-encapsulated feeds and micro-bound diets Feed additives: Binders, antioxidants, probiotics, enzymes, pigments, growth promoters, feed stimulants; use of preservatives.</p>	10
III	<p>Feed formulation, manufacture & storage Feed ingredients: selection, nutrient composition and nutrient availability. Feed formulation and manufacturing – extrusion processing and steam pelleting - grinding, mixing and drying, pelletization, and packing Microbial, insect and rodent damage of feed, chemical spoilage during storage period and feed storage methods.</p>	15
IV	<p>Feeding methods Feeding devices and methods: Manual feeding, demand feeders, automatic feeders, surface spraying, bag feeding & tray feeding Feeding schedules: Frequency of feeding, feeding rates and ration size Feed evaluation: feed conversion ratio, feed conversion efficiency and protein efficiency ratio.</p>	15
V	<p>Nutritional pathology of fish and shrimp Protein (Essential amino acid) and Lipid (Essential fatty acid) deficiency disorders; Fatty liver disease in fishes Vitamin and mineral deficiency disorders Anti-nutrients and aflatoxins.</p>	10

**A.G& S.G.S.DEGREE COLLEGE OF ARTS & SCIENCE, VUYYURU – 521165, KRISHNA
Dt.,A.P. (AUTONOMOUS)
SEMESTER-IV**

Model Question paper

w.e.f. 2021 – 2022

Paper Title: Fish Nutrition & Feed Technology

Paper Code: AQU-401

Time: 3 hrs

Max.Marks:70

Section -A

I. Answer any FOUR of the following

Draw labeled diagram wherever necessary

4x5=20M

1. Lipids
2. Checktray
3. Feed conversion efficiency
4. probiotics
5. Extrusion processing
6. Feed storage methods
7. Bag feeding
8. Aflatoxins

Section -B

Answer any FIVE of the following

5x5=50 M

Draw labeled diagrams wherever necessary

9. Explain essential amino acids required for cultivable fish
10. Describe various carbohydrates and micronutrients required for different stages of cultivable fish
11. Explain various feeds
12. Describe different feeding methods.
13. Explain nutrient composition and nutrient availability of feed ingredients..
14. Describe Enzymes and growth promoters
15. Explain Protein and Vitamin deficiency symptoms.
16. Describe the importance of natural and supplementary feeds.

**A.G& S.G.S.DEGREE COLLEGE OF ARTS & SCIENCE, VUYURU 521165, KRISHNA Dt., A.P.
(AUTONOMOUS)**

SEMESTER-IV

Guide lines to the paper setter

w.e.f. 2021 – 2022.

Paper Title:Fish Nutrition & Feed Technology .

Paper Code: AQU-401

Time: 3 hrs

Max.Marks:70

Note: 1. Answer **any four** questions out of eight in Part-A. Each question carries five marks. 4 X 5= 20M.

2. Answer any **five** questions out of eight in Part-B. Each question carries 10 marks. 5 X 10= 50M.

	PART	Unit – I	Unit – II	Unit – III	Unit – IV	Unit – V
5 Marks Questions	A	2	2	2	1	1
10 Marks Questions	B	2	2	1	1	2
Weightage		30	30	20	15	25

Note: 1. please provide the scheme of valuation for the paper.

2. Question paper should be both in English and Telugu media.

ZOOLOGY PRACTICAL SYLLABUS

PAPERS – IV

w.e.f. 2021 – 2022.

Period: 24

Max.Marks:50

Credits: 2

Paper Title: Fish Nutrition & Feed Technology

Paper Code: AQU-401P

PRACTICALS: (Any 8 as per the local Industry needs and Requirement)

1. Estimation of protein content in aquaculturefeeds
2. Estimation of carbohydrate content in aquaculturefeeds
3. Estimation of lipid content in aquaculturefeeds
4. Estimation of ash in aquaculturefeed
5. Study of water stability of pelletfeeds
6. Feed formulation and preparation in the lab
7. Study of binders used in aquaculturefeeds
8. Study of feed packing materials
9. Study of physical and chemical change during storage
10. Study on physical characteristics of floating and sinking feeds
11. Visit to a aqua-feed production unit
12. Visit to a farm for studying feeding practices

EXTERNAL PRACTICAL- IV

MODEL QUESTION PAPER –IV
2hrs/week)

Code: AQU-401P

Time: 3 hrs.

Max.marks: 25m.

I.Estimation of carbohydrate content in aquaculture feeds	7M.
II. Estimation of ash in aquaculture feed	5M.
III.Study of feed packing materials	5M
IV.Study of physical and chemical change during storage	5M
V. Viva.	3M
TOTAL: -----	25M.

Guide lines for the practical Examiners

- I:Estimation of carbohydrate content in aquaculture feeds (5marks notes & Result 2 mark .)
- II :Estimation of ash in aquaculture feed(5 marks notes)
- III :Study of feed packing materials (5 marks notes)
- IV. Study of physical and chemical change during storage (5 marks notes)

INTERNAL PRACTICAL- IV

w.e.f. 2021-2022.

(2 hrs/week).

Practical –IV

MODEL QUESTION PAPER -IV

Max.marks:25M.

Time: 3hrs.

Code: AQU-401P.

3. Attendance	-----	05M.	
4. Record	-----	10M.	
5. Field trip	-----	05M	
6. Assignment	-----	05M.	Total ----- 25M.

ADUSUMILLI GOPALAKRISHNAIAH & SUGAR CANE GROWERS SIDDHARTHA DEGREE COLLEGE OF ARTS & SCIENCE, VUYYURU-521165, KRISHNA Dt., A.P. (AUTONOMOUS).

NAAC reaccredited at 'A' level

Autonomous

ISO 9001-2015 Certified

Title of the Paper: **FISH HEALTH MANGEMENT**

Semester: - IV

Course Code	<i>AQU-402</i>	Course Delivery Method	Class Room/Blended Mode - Both
Credits	3	CIA Marks	30
No. of Lecture Hours/ Week	4	Semester End Exam Marks	70
Total Number of Lecture Hours	60	Total Marks	100
Year of Introduction : 2021-22	Year of Offering 2021-2022	Year of Revision –	Percentage of Revision:

Learning Objectives:

1. To understand the Principles of disease diagnosis and fish healthmanagement.
2. To know the prophylactic and therapeutic methods to control thediseases.
3. T understand the defense mechanism and immune system in fish andshrimp.
4. To gain detailed knowledge on the disease symptoms, causative agent, preventive measures and treatment for microbial, parasitic, nutritional and environmental disorders in fish andshrimp.
5. To understand the diagnosis tools that are followed in field of aquaculture and vaccine production for fishimmunization.
6. To know the significance of Quarantine, Biosecurity and SPF seed in the health management of fish andshrimp.

Course outcomes:

CO1: Provide students with knowledge about fish diseases and pathological aspects of diseases.

CO2: Learn about Fungal, Viral and Bacterial diseases of finfish.

CO3: Learn about major shrimp viral, bacterial and protozoan diseases and prevention and therapy methods.

CO4: Gain knowledge of Nutritional deficiency related diseases and antibiotic and chemotherapeutics.

CO5: Understand and learn the importance of diagnostic tools in identification of diseases andapplication and development of vaccines. To know about production of disease freeseeds andgood feed management

Syllabus
Course Details

Unit	Learning Units	Lecture Hours
I	<p>Introduction Principles of disease diagnosis and fish health management. Prophylaxis, Hygiene and Therapy of fish diseases. Defence mechanism in finfish and shellfish – specific and non-specific immunosystem. Role of stress and host defence mechanism in disease development - Host, pathogen and environment interaction.</p>	10
II	<p>Fish Diseases Clinical symptoms, pathology, prevention and therapy of Viral diseases: Viral Haemorrhagic septicemia, Infectious Hematopoietic Necrosis (IHN). Bacterial diseases: Epizootic ulcerative syndrome, Infectious abdominal dropsy, Bacterial gill disease, Columnaris disease, Tail and finrot. Fungal diseases: Saprolegniasis and Branchiomycosis. Protozoan diseases: Ichthyophthiriasis, Myxoboliasis/ Whirling disease, Enterococcidiasis. Helminthic and Crustacean parasitic diseases: Gyrodactylosis and Dactylogyrosis; Argulosis and Lernaeiasis.</p>	10
III	<p>Shrimp Diseases Clinical symptoms, pathology, prevention and therapy of Viral diseases: White spot syndrome, Monodon Baculovirus, Infectious hypodermal and haematopoietic necrosis virus, Hepato Pancreatic parvo like virus, Yellow head baculovirus, Taura Syndrome. Bacterial diseases: Vibriosis, white gut disease, loose shell syndrome, Acute Hepato-pancreatic Necrosis Disease (Early Mortality Syndrome, EMS) Fungal diseases: Hepatopancreatic microsporidiosis (HPM) by <i>Enterocytozoon hepatopenaei</i> (EHP), <i>Lagenidium</i> and <i>Fusarium</i> disease. Protozoan diseases: ectocommensal protozoa – <i>Zoothamnium</i> and <i>Acineta</i>.</p>	15
IV	<p>Nutritional and Environmental disorders Clinical symptoms, pathology, prevention and therapy of Fish: Protein (Essential amino acid) and Lipid (Essential fatty acid) deficiency disorders; Vitamin and mineral deficiency disorders; Fatty liver disease; Gas bubble disease, Asphyxiation. Shrimp: Soft shell syndrome, Blue disease/Pigment deficiency syndrome, Red disease, Cramp tail syndrome, Black gill disease, Muscle necrosis, Black death disease. Role of gut probiotics in health management of fish and shrimp. Bioremediation of soil and water as a strategy for health management in ponds.</p>	15
V	<p>Fish Health Management Diagnostic tools – immune detection- DNA/RNA technique – molecular diagnosis of viral diseases. Principles and methods of vaccine production and fish immunization. Quarantine and health certification in aquaculture. Significance of Biosecurity and Specific pathogen free seed (SPF) in health management.</p>	10

Semester –IV

w.e.f. 2021-2022

Model question paper

Title of the paper: Fish health management.

Code – AQU-402

Time: 3hrs.

Max.marks: 70

Section – A

4 x 5= 20.

Answer any **four** questions. Each question carries **five** marks. Draw neat labeled diagrams wherever necessary.

1. Necrosis.
2. Atrophy
3. Lagenidium diseases
- 4 Bacterial kidney disease.
5. Monodon Bacculovirus
6. Yellow head bacculovirus
7. Lipid liver degeneration
- 8, Zero water exchange.

Section – B

5 x 10 =50.

Answer any **five** questions. Each question carries **Ten** marks. Draw neat labeled diagrams wherever necessary.

9. Write an essay on any two nutritional Requirements for cultivable fish?
10. Explain the changes in cell metabolism?
11. Explain about Bacterial diseases of shell fish?
12. Explain about channel cat fish viral disease prevention and therapy?
13. Describe the Protozoan diseases??
14. Write an essay on genetically and environmentally induced diseases?
15. Explain about application and development of vaccines?
16. Methods and regulations for transplants?

A.G. & S.G.Siddhartha Degree College of Arts & Science, Vuyyuru – 521165,
Krishna Dt. A.P. (Autonomous)

Semester - IV

Guide lines to the Paper Setter.

Title of the paper: Fish health management

Code – AQU-402

Time: 3hrs.

Max. Marks: 70.

1. Answer any **four** questions out of eight in Section – A. Each question carries five marks. $4 \times 5 = 20M$.

2. Answer any **five** questions out of eight in Section – B. Each question carries Ten marks. $5 \times 10 = 50M$.

	Section	UNIT-I	UNIT-II	UNIT-III	UNIT-IV	UNIT-V
5 Marks Questions	A	2	2	2	1	1
10 Marks Questions	B	1	2	2	1	2
Weightage		20	30	30	15	25

Note: 1. please provide the scheme of valuation for the paper.

2. Question paper should be in English medium.

w.e.f. 2021-2022
MAX.MARKS : 50.
(2hrs/week)

Code : AQU- 402P

PRACTICAL SYLLABUS

1. Enumeration of Bacteria by TPC Method
2. Enumeration of total Coli forms
3. Observation of gross pathology and external lesions of fish and prawn with reference to the common diseases in aquaculture
4. Examination of pathological changes in gills and gut lumen, lymphoid organ, muscles and nerves of fish
5. Examination of pathological changes in gut lumen, hepatopneacas, lymphoid organ, muscles and nerves of prawn and shrimp
6. Collection, processing and analysis of data for epidemiological investigations of viraldiseases
7. Bacterial pathogens – isolation, culture and characterization
8. Identification of parasites in fishes: Protozoan, Helmiths, Crustaceans
9. Antibigrams – preparation and evaluation
10. Molecular and immunological techniques; Biochemical tests; PCR; ELISA; Agglutination test; Challenge tests; Purification of virus for development of vaccines (Demonstration at institutes/labs)
11. Estimation of dose, calculation of concentration, methods of administration of various chemotherapeutics to fish and shell fish
12. Estimation of antibiotics used in aquaculture practices
13. Estimation of probiotics used in aquaculture
14. Field visit to farm for health monitoring and disease diagnosis

PRESCRIBED BOOK(S):

1. Shaperclaus W. 1991 Fish Diseases- Vol.I & II. Oxonian Press Pvt.ltd
2. Roberts RJ 1989. Fish pathology. Bailliere Tindall, New York
3. Lydia Brown 1993. Aquaculture for veterinarians- fish husbandray and medicine. Pergamon Press. Oxford

REFERENCES:

1. Shankar KM & Mohan CV. 2002. Fish and Shellfish Health Management. UNESCO Publ. Sindermann CJ. 1990
2. Walker P & Subasinghe RP. (Eds.). 2005 Principal Diseases of Marine Fish and Shellfish. Vols. I, II. 2nd Ed. Academic Press
3. DNA Based Molecular Diagnostic Techniques: Research Needs for Standardization and Validation of the Detection of Aquatic Animal Pathogens and Diseases. FAO Publ. Wedmeyer G, Meyer FP & Smith L. 1999.
4. Bullock G et.al., 1972 Bacterial diseases of fishes. TFH publications, New Jersey
5. Post G 1987. Text book of Fish Health. TFH publications, New Jersey
6. Johnson SK 1995. Handbook of shrimp diseases. Texas A & M University, Texas

EXTERNAL PRACTICAL-IV

MODEL QUESTION PAPER –IV

(2hrs/week)
Code: AQU-402P

Time: 3 hrs.

Max.marks: 25m.

I.Estimation of antibiotics used in aquaculture practices	5M.
II. Biochemical tests	5M.
II.	5M
IV. Identify, draw labeled diagram & write notes on A, B, C, D E	5X2=10M

TOTAL: ----- 25M.

Guide lines for the practical Examiners

I:Estimation of carbohydrate content in aquaculture feeds (4 marks notes & Result 1 mark.)

II:Biochemical tests. (5 marks notes)

III:ELISA (5 marks notes)

IV. ½ Mark for identification, ½ Mark for labeled diagram & 1 Mark for notes for each question.

4 specimens / slides / models.

INTERNAL PRACTICAL-IV

w.e.f. 2021-2022.
(2 hrs/week).

Code: AQU-402P.

MODEL QUESTION PAPER -IV

Max.marks:25M.

Time: 3hrs.

1. Attendance	----- 05M.
2. Record	----- 10M.
3. Field trip	----- 10M
	Total ----- 25M.

**ADUSUMILLI GOPALAKRISHNAIAH & SUGAR CANE GROWERS SIDDHARTHA
DEGREE COLLEGE OF ARTS & SCIENCE, VUYURU-521165, KRISHNA Dt., A.P.
(AUTONOMOUS).**

NAAC reaccredited at 'A' level
Autonomous –ISO 9001-2015 Certified

Title of the Paper: **Ornamental fishery**

Semester: - VI

Course Code	<i>AQU-601C</i>	Course Delivery Method	Class Room/Blended Mode - Both
Credits	3	CIA Marks	30
No. of Lecture Hours/ Week	4	Semester End Exam Marks	70
Total Number of Lecture Hours	60	Total Marks	100
Year of Introduction : 2021-22	Year of Offering 2021-2022	Year of Revision –	Percentage of Revision:

Objective of the course: The students understand Ornamental fishery.

Course outcomes:

Learning Objectives:

- This course has been designed to understand identification and classification of commercially important fishes and other aquatic vertebrates by the students
- The course objectives are to provide the students with an introductory knowledge of live bearers.
- The students will be required to identify common Marine Ornamental species available in and around their region using Ocean area.
- To gain detailed knowledge on the disease symptoms, causative agent, preventive measures and treatment in fish and shrimp.
- To understand the students will be required - Commercial production of aquarium fish and plants

COURSE OUTCOMES

At the end of the course, students will be able to:

CO1. Describe and identify the characters of commercially important ornamental fishes

CO2. Explain the procedure for transportation fish and feed preparation

CO3. Identify the diagnosing procedure for ornamental fish diseases

CO 4. Construct aquarium and analyse water quality parameters

CO5. Access the role of Mass production of aquarium plants

Syllabus

Course Details

Unit	Learning Units	Lecture Hours
I	UNIT- I: Introduction Aquarium and ornamental fishes – introduction Present status of Aquarium trade in the world and India Aquarium accessories – aerators, filters, lighters and heaters Water quality needs and different kinds of feeds.	10
II	UNIT-II: Fresh water ornamental fishes Live bearers, gold fish, koi, gourami, barbs and tetras, angel fish and cichlid fish Brood stock development, breeding, larval rearing and grow out. Larval feeds and feeding	10
III	UNIT-III: Marine ornamental fishes Varieties and habitat of marine ornamental fishes Major marine ornamental fish resources of India Collection and transportation of live fish, use of anaesthetics Breeding of marine ornamental fish. Other aquarium animals – sea anemones, lobsters, worms, shrimps, octopus and starfish	15
IV	UNIT-IV: Aquarium management Setting up fresh water, marine and reef aquariums. Water quality management for different types of aquariums. Common diseases of aquarium fish, diagnosis and treatment. Temperature acclimatization and oxygen packing for aquarium fish.	15
V	UNIT-V: Commercial production of aquarium fish and plants Commercial production units of ornamental fish- requirements and design. Commercial production of goldfish, live bearers, gouramies, barbs, angels and tetras. Mass production of aquarium plants. Retail marketing and export of ornamental fish.	10

A.G. & S.G.Siddhartha Degree College of Arts & Science, Vuyuru – 521165,
Krishna Dt. A.P. (Autonomous)

Semester –VI
Time: 3hrs

(Model question paper)

w.e.f. 2021-2022

Title of the paper: **Ornamental fishery**

Code – AQU-601C

Max.marks: 70

Section – A

Answer any **four** questions. Each question carries **five** marks. **4 x 5= 20.**

Draw neat labeled diagrams wherever necessary.

1. Aerators
2. Larval rearing
3. Gold fish
4. Use of anaesthetics
5. Lobsters
6. Diagnosis and Treatment of aquarium fish
7. Gouramies,
8. Retail marketing

Section – B

Answer any **five** questions. Each question carries **Ten** marks. **5 x 10 =50**

Draw neat labeled diagrams wherever necessary.

9. Describe the Present status of Aquarium trade in the world and India?
10. Write an essay on angel fish and cichlid fish?
11. Explain larval feeds and feeding?
12. Describe the Collection and transportation of live fish?
13. Explain Breeding of marine ornamental fish?
14. Water quality management for different types of aquariums?
15. Describe the Common diseases of aquarium fish?
16. Mass production of aquarium plants?

SEMESTER-VI

Time: 3 hrs

Guide lines to the paper setter

Paper Title: -Ornamental fishery.

Paper Code: AQU-601C

Max.Marks:70

Note: 1. Answer **any four** questions out of eight in Part-A. Each question carries five marks. 4X 5 = 20M.

2. Answer any **five** questions out of eight in Part-B. Each question carries 10 marks.
5 X 10 = 50M.

	PAR T	Unit –I	Unit – II	Unit-III	Unit – IV	Unit – V
5 Marks Questions	A	1	2	2	1	2
10 Marks Questions	B	1	2	2	2	1
Weightage		15	30	30	25	20

- Note:**
1. Please provide the scheme of valuation for the paper.
 2. Question paper should be both in English and Telugu media.

A.G. & S.G.SIDDHARTHA DEGREE COLLEGE OF ARTS & SCIENCE, VUYYURU-
521165, KRISHNA Dt.,A.P. (AUTONOMOUS)
AQUACULTURE

PRACTICAL - VI

w.e.f. 2021-2022

Code: AQU- 601P

MAX.MARKS : 50.

(2hrs/week)

PRACTICAL SYLLABUS

PRACTICALS:

1. Study of aerators – types and structures
2. Water circulation methods in aquarium and filtration
3. Collection and identification of aquarium plants
4. Identification of common marine aquarium fishes
5. Identification of common fresh water aquarium fishes
6. Breeding of egg layers
7. Breeding of live bearers
8. Evaluation of significance of aquaria for commercial and domestic use.

PRESCRIBED BOOK(S):

1. Dick Mills 1998. Aquarium fishes, Dorling Kindersly Ltd, London
2. Van Ramshort JD 1978. The complete aquarium encyclopedia, Elsevier

REFERENCES:

1. Jameson JD and Santhanan R 1996. Manual of ornamental fishes and farming technologies, Fisheries College and research institute, Tuticorn
2. Stephen Spotte 1993. Marine aquarium keeping. John wiley and sons, USA

A.G& S. G.S.DEGREE COLLEGE OF ARTS & SCIENCE, VUYURU - 521165,
KRISHNA Dt., A.P. (AUTONOMOUS)

Practical - VI

w.e.f. 2021 – 2022

Paper Code: AQU-601P

Max. Marks: 25

Model Question Paper (External)

-
1. Identify, draw labeled diagram & write notes on marine aquarium fishes. 4x2=8M
A , B, C & D
 2. Identify, draw labeled diagram & write notes on fresh water aquarium fishes. 4x2=8M
A , B, C & D
 3. Collection and identification of aquarium plants 5M
 4. Breeding of egg layers / Breeding of live bearers 4M
- Total-----25m

Guide lines for the practical Examiners

1. ½ Mark for identification, ½ Mark for labeled diagram & 1 Mark for notes for each question.
(4 specimens / slides / models.)
2. ½ Mark for identification, ½ Mark for labeled diagram & 1 Mark for notes for each question.
(4 specimens / slides / models.)
3. Collection and identification of aquarium plants submit field note book (5 marks).
4. Labeled diagrams 1 mark & 3 marks for notes (4marks)

**A. G.& S.G. SIDDHARTHA DEGREE COLLEGE OF ARTS & SCIENCE, VUYURU
INTERNAL PRACTICAL- III**

(Practical -III)

w.e.f. 2021-2022.

Code: AQU-601P.

MODEL QUESTION PAPER -III

Max.marks:25M.

Time: 3hrs.

1. Attendance ----- 05M.
2. Record -----10M.
3. Field note book. ----- 05M
4. Assignment ----- 05M.

Total ----- 25M.

**ADUSUMILLI GOPALAKRISHNAIAH & SUGAR CANE GROWERS SIDDHARTHA
DEGREE COLLEGE OF ARTS & SCIENCE, VUYURU-521165, KRISHNA Dt., A.P.
(AUTONOMOUS).**

NAAC reaccredited at 'A' level
Autonomous –ISO 9001-2015 Certified

Title of the Paper: Fish Processing Technology

Semester: - VI (CI-1)

Course Code	<i>AQU-602C</i>	Course Delivery Method	Class Room/Blended Mode - Both
Credits	3	CIA Marks	30
No. of Lecture Hours/ Week	4	Semester End Exam Marks	70
Total Number of Lecture Hours	60	Total Marks	100
Year of Introduction : 2021-22	Year of Offering 2021-2022	Year of Revision –	Percentage of Revision:

Learning Objective of the course:

- The students understand Fish Processing Technology
- Advanced treatment of the concepts – involved in the production, processing and acceptance of Fish processing Products derived from fish- Fish waste utilization

Course Outcomes:

CO1: After completing this course students can able to, deliver the different unit operations and its equipments involved in fish processing fishing resources.

CO2: Develop value added products from fish. Able to know about quality control of fish processing

CO3: Know about different methods of processing of fish Able to acquire a confident to get placement in any fish processing industry.

CO4: Students grow in understanding of Packing, Cold Storage and Export of Fishery Products.

CO5: Export of fishery products from India - major countries

Syllabus
Course Details

Unit	Learning Units	Lecture Hours
I	UNIT- I: : Introduction: Principles of fish preservation. Importance of hygiene and sanitation in fish handling. Quality of water and ice in fish handling and processing. Preparation of ice. Different types of ice used in the seafood industry and their merits. Preservation by refrigerated seawater and chilled sea water	10
II	UNIT-II:Freezing and Canning: Fundamental principles involved in chilling and freezing of fish and fishery products. Various freezing methods. Freezing of shrimps and fishes. Changes during the cold storage of fish and fishery products. Principles involved in canning of fish. Different types of containers. Different stages of canning of Tuna. Retortable pouch processing.	10
III	UNIT-III: Drying, Smoking and Freeze-drying: Principles of smoking, drying and salting of fish, factors affecting drying. Traditional drying / curing methods. Different types of drying. Drying of fish and prawns. Packing and storage of dried products. Spoilage of dried products. Preventive measures. Standards for dry fish products. Cold smoking. Principles of freeze drying. Accelerated freeze drying and packing of freeze dried products. Modern methods of preservation by irradiation and modified atmospheric storage.	15
IV	UNIT-IV: Packing, Cold Storage and Export of Fishery Products: Functions of packing. Different types of packing materials and its quality evaluation. Packing requirements for frozen and cured products. Statutory requirements for packing. Labeling requirements. Different types of cold storages. Insulated and refrigerated vehicles.	15
V	UNIT-V: Export of fishery products from India - major countries, important products, export documents and procedures. Prospects and constraints in export including tariff and non- tariff barriers, marine insurance, export incentives, registered exporters	10

Semester –VI
w.e.f. 2021-2022
Time: 3hrs

Model question paper

Title of the paper: Fish Processing Technology
max.marks: 70

Code – AQU-602P

Section – A

Answer any **four** questions. Each question carries **five** marks. **4 x 5= 20.**

Draw neat labeled diagrams wherever necessary.

1. Preparation of ice
2. Canning
3. Various freezing methods
4. Drying and salting of fish
5. Spoilage of dried products
6. Functions of packing
7. Labeling requirements.
8. Registered exporters

Section – B

Answer any **five** questions. Each question carries **Ten** marks. **5 x 10 =50**

Draw neat labeled diagrams wherever necessary.

9. Describe the Principles of fish preservation?
10. Changes during the cold storage of fish and fishery products.?
11. Describe the Different stages of canning of Tuna?
12. Explain Different types of drying?.
13. Modern methods of preservation by irradiation and modified atmospheric storage?
14. Describe the Different types of packing materials and its quality evaluation?
15. Packing requirements for frozen and cured products?.
16. Explain about export documents and procedures?

SEMESTER-VI

Time: 3 hrs

Guide lines to the paper setter

Paper Title: -Fish Processing Technology

Paper Code: AQU-602C

Max.Marks:70

Note: 1. Answer **any four** questions out of eight in Part-A. Each question carries five marks.4X 5 = 20M.

2. Answer any **five** questions out of eight in Part-B. Each question carries 10 marks.5 X 10 = 50M.

	ART	Unit –I	Unit – II	Unit-III	Unit – IV	Unit – V
5 Marks Questions	A	1	2	2	2	1
10 Marks Questions	B	1	2	2	2	1
Weightage		15	30	30	30	15

- Note:**
1. please provide the scheme of valuation for the paper.
 2. Question paper should be both in English and Telugu media.

A.G. & S.G.SIDDHARTHA DEGREE COLLEGE OF ARTS & SCIENCE, VUYYURU-521165,
KRISHNA Dt.,A.P. (AUTONOMOUS)

AQUACULTURE
PRACTICAL -VIII

w.e.f. 2021-2022.
MAX.MARKS : 50.
(2hrs/week)

Code :AQU- 602P

PRACTICAL SYLLABUS

Practical I Title: Fish Processing Technology and Quality Control

Experiments:

1. Determination of moisture content in fish and fishery products
2. General description –freezing
3. Processing shrimp
4. Filleting of fish
5. Drying of fish
6. Organoleptic analysis of fish
7. Preparation of fishery by products
8. Preparation of shark fin rays fish maws, chitin, fish wafer
9. Fish pickling
10. Value added fishery products, fish curry, cutlets fish finger.
11. Preparation of surimi

Filed visit:

1. Visit to sea food pre-processing plants
2. Visit to fish processing plants

Text books:

1. K.Gopakumar, Fish Processing Technology, ICAR, New Delhi
2. T.K. Govindan, Fish Processing Technology Oxfor & IBH Publication Co.
3. K.K. Balachandran Fish Canning – Principles & Practices.
4. Borgstrom,G. Fish as Food.
5. K.K. Balachandran, Postharvest Technology in Fish and Fishery Products. 6. Moorjani,M.V. Fish Processing in India.
7. Connell,J.J. Advances in Fishery science and Technology.
8. CIFT. Manual of Quality Control in Fish and Fishery Products. 9. Gopakumar,K. Fish Packaging Technology

Reference Books:

1. A.M.Martin, Fisheries – Processing Chapman & Hall, Madras 2. Ed.G.M.Hall – Fish Processing Technology Chopra & Hall. Madras.

Practical - VI

w.e.f. 2021 – 2022

Paper Code: AQU-602P

Max. Marks: 25

Model Question Paper (External)

1. General description –freezing.	5 m
2. Processing shrimp.	5 m
3. Drying of fish	5m
4. Preparation of fishery by products.	5m
5. Fish pickling	5m

Total-----25m

Guide lines for the practical Examiners

1. General description-5m
2. Processing shrimp notes-5m
3. Drying of fish. 5m
4. Preparation of fishery by products notes.5m
5. Fish pickling notes.5m

A. G.& S.G. SIDDHARTHA DEGREE COLLEGE OF ARTS & SCIENCE, VUYURU-
521165

INTERNAL PRACTICAL

w.e.f. 2021-2022.
(2 hrs/week).

Code: AQU-602P.

MODEL QUESTION PAPER

Max.marks:25M.

Time: 3hrs.

1. Attendance	-----	05M.
2. Record	-----	10M.
3. Field note book.	-----	10M

Total ----- 25M.

**ADUSUMILLI GOPALAKRISHNAIAH & SUGAR CANE GROWERS SIDDHARTHA
DEGREE COLLEGE OF ARTS & SCIENCE, VUYURU-521165, KRISHNA Dt., A.P.
(AUTONOMOUS).**

NAAC reaccredited at 'A' level
Autonomous –ISO 9001-2015 Certified

Title of the Paper: **Fishery Microbiology and Fishery by-products**

Semester: - VI (C1-2)

Course Code	AQU-603C	Course Delivery Method	Class Room/Blended Mode - Both
Credits	3	CIA Marks	30
No. of Lecture Hours/ Week	4	Semester End Exam Marks	70
Total Number of Lecture Hours	60	Total Marks	100
Year of Introduction : 2021-22	Year of Offering 2021-2022	Year of Revision –	Percentage of Revision:

Objective of the course: The students understand Fishery Microbiology and Fishery by-products.

Course outcomes

CO1: The ecosystem and taxonomy of microbes will be understood by the students along with prokaryotic and eukaryotic divisions

CO2: Hands on techniques on handling the microscopes in the class and instrumentation lab will be elaborate study of microbial organisms advanced techniques for easy and speedy identification will be known

CO3: Screening, isolation and enumeration of microbes using different media and application of advanced techniques for easy and speedy identification will be known

CO4: Students will be able to discuss Fishery By - products.

CO5: The practical knowledge of Value Added Products will be achieved by the students .

Syllabus
Course Details

Unit	Learning Units	Lecture Hours
I	<p>UNIT- I: Introduction: History and development of microbiology –Different members of the microbial community – General characteristics of bacteria, fungi, viruses, algae and protozoan's. Ultra structure of prokaryotic cell – structure and function of bacterial cell wall, plasma membrane, capsule, flagella and endospore. Structure of fungi and yeast cell. Ultra structure of virus – classification of viruses, Life cycle bacteriophages - lytic and lysogenic cycle.</p>	10
II	<p>UNIT-II: Aquatic Microbiology: Microflora of aquatic environment, Different culture techniques. Nutrition and growth of bacteria – different types of media for isolation of bacteria and fungi. Isolation, enumeration, preservation and maintenance of cultures. Routine tests for identification of bacteria – morphological, cultural biochemical and serological. Basics of mycological and virology techniques</p>	15
III	<p>UNIT-III: Fish Microbiology: Perish ability of seafood – Fish as an excellent medium for growth of microorganisms. Spoilage microflora of fish and shellfish. Intrinsic and extrinsic factors affecting spoilage.</p>	10
IV	<p>UNIT-IV:Fishery By-Products: Fish meal, fish protein concentrate, shark fin rays, fish maws, isinglass, fish liver oil, fish body oil, fish hydrolysates, chitin, chitosan, glucosamine hydrochloride, squalene, pearl essence, ambergris, gelatin, beche-de-mer, fish silage, fish ensilage and seaweed products like agar, alginic acid and carrageen.</p>	15
V	<p>UNIT-V: Value Added Products. Value addition in sea food. Different types of value added products from fish and shell fishes – status of value addition in Indian seafood sector. Advantages of value addition. Fish mince and Surimi. Analog and fabricated products. Preparation of coated fishery products. Different types of batter and breading and its applications. Preparation of products viz. fish / prawn pickle, fish wafers, prawn chutney powder, fish soup powder, fish protein hydrolysate, fish stacks, fillets, fish curry, mussel products, marinated products.</p>	10

A.G. & S.G.Siddhartha Degree College of Arts & Science, Vuyyuru – 521165,
Krishna Dt. A.P. (Autonomous)

Semester –VI

w.e.f. 2021-2022

Time: 3hrs

Model question paper

Title of the paper: Fishery Microbiology and Fishery by-products

Code – AQU-603C

Max.marks: 70

Section – A

Answer any **four** questions. Each question carries **five** marks. **4 x 5= 20.**

Draw neat labeled diagrams wherever necessary.

1. General characteristics of bacteria
2. Plasma membrane
3. Isolation
4. Spoilage microflora of fish
5. Carrageen
6. Isinglass
7. Advantages of value addition.
8. Mussel products

Section – B

Answer any **five** questions. Each question carries **Ten** marks. **5 x 10 =50**

Draw neat labeled diagrams wherever necessary.

9. Describe the Ultra structure of prokaryotic cell?
10. Life cycle of bacteriophages?
11. Different types of media for isolation of bacteria and fungi?
12. Write an essay on preservation and maintenance of cultures.?
13. Intrinsic and extrinsic factors affecting spoilage?
14. Describe the Fishery By-Products?
15. Explain about Value addition in sea food.
16. Different types of batter and bread and its applications?

SEMESTER-VI

Time: 3 hrs

Guide lines to the paper setter

Paper Title:-Fishery Microbiology and Fishery by-products.

Paper Code: AQU-603C

Max.Marks:70

Note:

1. Answer **any four** questions out of eight in Part-A. Each question carries five marks.4X 5 = 20M.
2. Answer any **five** questions out of eight in Part-B. Each question carries 10 marks.5 X 10 = 50M.

	PART	Unit –I	Unit – II	Unit-III	Unit – IV	Unit – V
5 Marks Questions	A	2	2	1	2	1
10 Marks Questions	B	2	2	1	1	2
Weightage		30	30	15	20	25

- Note:**
1. Please provide the scheme of valuation for the paper.
 2. Question paper should be both in English and Telugu media.

AQUACULTURE
PRACTICAL -VI

w.e.f. 2021-2022.
MAX.MARKS : 50.
(2hrs/week)

Code :AQU- 603P

PRACTICAL SYLLABUS

Practical II Title: Fishery Microbiology and Quality Control

Experiments/Activities

1. Sterilization technique- dry heating, autoclaving
2. Media preparation
3. Isolation and maintenance of bacteria from fishes and water.
4. Gram staining of bacteria
- 5.Enumeration of bacteria by TPC method
6. Enumeration of total coli forms.
7. Evaluation of fish / fishery products for organoleptic, chemical and microbial quality

Collection:

1. Collection of fishery by-products.

Text Books:

1. Pelzar, Reid & Chan – Microbiology
2. Prescott, Harley & Klein – Microbiology
3. Adeloger, Ingra & Wheates – Introduction to Microbial World
4. Windsor and Barlow. Introduction to Fishery Byproducts.
5. CIFT. Proceedings on Summer Institute on Non-traditional Diversified Fish Products &Byproducts.
6. Anon. Productivity in Aquatic Bodies.
7. Chincheste,C.O. and Graham,H.D. Microbial Safety of Fishery Products.
8. Amerine,M.A. and Pangborm,R.M. Principles of Sensory Evaluation of Foods.
9. Connell,J.J. Control of Fish Quality
10. Bigh,E.G. Seafood Science and Technology
11. Gopakumar.K Tropical Fishery Products

Reference Books

1. Kreuzer,R. Fishery Products.
2. Borgstrom,G .Fish as Food
3. Suzuki,T. Fish and Krill Protein: Processing Technology

A.G& S. G.S.DEGREE COLLEGE OF ARTS & SCIENCE, VUYYURU -
521165, KRISHNA Dt., A.P. (AUTONOMOUS)

Practical – VI

Paper Code: AQU-603P

Max. Marks: 25 Model Question Paper (External)

1. Write notes on autoclaving. 5M
 2. Write notes on Media preparation any two. 2x2¹/₂=5M
 3. Gram staining of bacteria 5M
 4. Enumeration of bacteria by TPC method 5M
 5. Enumeration of total coli forms. 5M
- Total-----25m

**A. G.& S.G. SIDDHARTHA DEGREE COLLEGE OF ARTS & SCIENCE,
VUYYURU-521165**

INTERNAL PRACTICAL- VI

(2 hrs/week).

. Code: AQU-603P.

MODEL QUESTION PAPER

Max.marks:25M.

Time: 3hrs

1. Attendance ----- 05M.
2. Record -----10M.
3. Field note book. ----- 10M

Total ----- 25M.

**DUSUMILLI GOPALAKRISHNAIAH & SUGAR CANE GROWERS SIDDHARTHA
DEGREE COLLEGE OF ARTS & SCIENCE, VUYYURU-521165, KRISHNA Dt., A.P.
(AUTONOMOUS).**

NAAC reaccredited at 'A' level
Autonomous –ISO 9001-2015 Certified

Title of the Paper: **Quality Control in Processing Plants**

Course Code	<i>AQU-604C</i>	Course Delivery Method	Class Room/Blended Mode - Both
Credits	3	CIA Marks	30
No. of Lecture Hours/ Week	4	Semester End Exam Marks	70
Total Number of Lecture Hours	60	Total Marks	100
Year of Introduction : 2021-2022	Year of Offering 2021-2022	Year of Revision –	Percentage of Revision:

Objective of the course: The students understand Quality control in processing plants.

Course outcomes:

CO1: Explain the application of fish quality and quality standards.

CO2: To understand the different types of water treatments

CO3: Examine the chemical and microbiological quality of fish and fish products.

CO4: To gain the knowledge on different types of processing plants.

CO5: Review of legislative approaches for the management of food safety

Syllabus

Course Details

Unit	Learning Units	Lecture Hours
I	UNIT- I: Quality management, total quality concept and application in fish trade. Quality assessment of fish and fishery products - physical, chemical, organoleptic and microbiological. Quality standards. Quality Assurance. Inspection and quality assurance.	10
II	UNIT-II: Fish inspection in India, process; water quality in fishery industry, product quality, water analysis, treatments, chlorination, ozonisation, UV radiation, reverse osmosis, techniques to remove pesticides and heavy metals.	10
III	UNIT-III Sensory evaluation of fish and fish products, basic aspects, different methods of evaluation, taste panel selection & constitution, statistical analysis. Quality problem in fishery products: good manufacturing practices. HACCP and ISO 9000 series of quality assurance system, validation and audit. national and international standards, EU regulation for fish export trade,	15
IV	UNIT-IV: IDP and SAT formations in certification of export worthiness of fish processing units, regulations for fishing vessels pre-processing and processing plants, EU regulations. Factory sanitation and hygiene: National and international requirements, SSOP.	10
V	UNIT-V: Hazards in sea foods: Sea food toxins, biogenic amines, heavy metals and industrial pollutants. Infection and immunity, Microbial food poisoning, bacteria of public health significance in fish /fishery products / environments - Salmonella, Clostridia, Staphylococcus, E. coli, Streptococcus, Vibrio, Aeromonas, Listeria, Yersinia, Bacillus. Laboratory techniques for detection and identification of food poisoning bacteria. Mycotoxins in cured fish, bacterial associated with fish disease.	15

A.G. & S.G.Siddhartha Degree College of Arts & Science, Vuyuru – 521165,
Krishna Dt. A.P. (Autonomous)

Semester –VI
Time: 3hrs

w.e.f. 2021-2022

Model question paper

Title of the paper:Quality Control in Processing Plants

Code – AQU-604C

Max.marks: 70

Section – A

Answer any **four** questions. Each question carries **five** marks. **4 x 5= 20.**

Draw neat labeled diagrams wherever necessary.

1. Quality standards
2. UV radiation
3. Chlorination,
- 4.Different methods of evaluation
5. Validation and audit
- 6.SSOP
- 7.Mycotoxins in cured fish.
8. Salmonella.

Section – B

Answer any **five** questions. Each question carries **Ten** marks. **5 x 10 =50**

Draw neat labeled diagrams wherever necessary.

9. Describe the total quality concept and application in fish trade?
10. Write an essay on Quality Assurance?
11. Discuss about the techniques to remove pesticides and heavy metals.?
12. Write an essay on Hazard Analysis Critical Control Point (HACCP)?.
13. Explain about good manufacturing practices.?
14. Describe the Factory sanitation and hygiene?
15. Explain about the Microbial food poisoning?
16. Laboratory techniques for detection and identification of food poisoning bacteria?

A.G& S.G.S.DEGREE COLLEGE OF ARTS & SCIENCE, VUYURU 521165, KRISHNA Dt.,
A.P. (AUTONOMOUS)

SEMESTER-VI

Time: 3 hrs

Guide lines to the paper setter

Paper Title:- Quality Control in Processing Plants

Paper Code: AQU-604C

Max.Marks:70

1. Answer **any four** questions out of eight in Part-A. Each question carries five marks. 4X 5 = 20M
2. Answer any **five** questions out of eight in Part-B. Each question carries 10 marks. 5 X 10 =50M

	PAR T	Unit –I	Unit – II	Unit-III	Unit – IV	Unit – V
5 Marks Questions	A	1	2	2	1	2
10 Marks Questions	B	2	1	2	1	2
Weightage		25	20	30	15	30

- Note:**
1. Please provide the scheme of valuation for the paper.
 2. Question paper should be both in English and Telugu media.

A.G. & S.G.SIDDHARTHA DEGREE COLLEGE OF ARTS & SCIENCE, VUYURU-
521165, KRISHNA Dt.,A.P. (AUTONOMOUS)

AQUACULTURE

PRACTICAL - X

w.e.f. 2021-2022

Code :AQU- 604P

MAX.MARKS : 50.

(2hrs/week)

PRACTICAL SYLLABUS
Practical III – PROJECT WORK

Reference Books

1. Ellis Harward. 18 Felix S, Riji John K, Prince Jeyaseelan MJ & Sundararaj V. 2001
Bacterial Fish Pathogens (Diseases in Farm and Wild)
2. Fish Disease Diagnosis and Health Management. Fisheries College and Research
Institute, T.N. Veterinary and Animal Sciences University. Thoothukkudi. Inglis V,
Roberts RJ & Bromage NR. 1993

**A.G& S.G.SIDDHARTHA DEGREE COLLEGE OF ARTS &
SCIENCE**

VUYYURU-521165, KRISHNA Dt., A.P.(Autonomous)

Accredited by NAAC with "A" Grade

2021-2022



DEPARTMENT OF BOTANY







MINUTES OF BOARD OF STUDIES

ODD SEMESTER

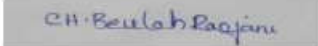
27-10-2021

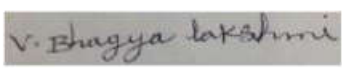
Minutes of the meeting of Board of studies in Botany for the Autonomous courses of AG & SG Siddhartha Degree College of Arts & Science, Vuyyuru, held at 10:30 A.M on 27-10-2021 in the Department of Botany through online.

Members Present:-

- 1)..........Chairman Head, Department of Botany
(Smt. CH. Beulah Ranjani) AG & SG S Degree College of Arts &
 Science
 Vuyyuru- 521165.
- 2)..........University Department of Botany &
(Sri. Dr. K. Ramesh) Nominee Head (I/c) Botany,
 The Hindu College, Guntur .
- 3)..........Academic Lecture in Botany,
(Sri. Dr. Ch. Srinivasa Reddy) Council Nominee SRR& CVR Govt. Degree College,
 Vijayawada, 520004.
- 4)..........Academic Head, Department of Botany
(Smt. V. Bhagya Lakshmi) Council Nominee SDMSK,
 Vijayawada,
- 5)..........Industrialist. Natural farming.
(Sri. S. Krishna Suman) yakamuru
 Vuyyuru, Krishna d.t
- 6)..........Member Ad hoc Lecturer in Botany
(Sri. N. Ramana Rao) AG & SGS Degree College of Arts &
 Science (Autonomous),
 Vuyyuru-521165.
- 7)..........Member Ad hoc Lecturer in Botany
(Ms. G. Rebecca Rachel) AG & SGS Degree College of Arts &
 Science (Autonomous),
 Vuyyuru-521165.
- 8)..........student representative Lecturer in chaitanya college,
(Ms K. Anusha MSc) Gudiwada

Agenda for B.O.S Meeting:

1. To recommend the syllabi (Theory & Practical), Model question paper for I Semester of I B.Sc (BZC, AQUA) in the academic year 2021-22.
2. To recommend the syllabi (Theory & Practical), Model question paper & Guide lines for III Semester of II B.Sc (BZC, AQUA) in the academic year 2021-22.
3. To recommend the syllabi (Theory & Practical), Practical syllabus, Model question paper & Guide lines for V Semesters of III B. Sc (BZC, AQUA) for the academic year 2021-22
4. To recommend the Blue print for the Semester –End exams for I, III & V Semesters of I, II & III B. Sc (BZC, AQUA) for the academic year 2021-22.
5. To recommend the teaching and evaluation methods to be followed under Autonomous statues.
6. Any other matter.

CH Beulah Rajan

Chairman

RESOLUTIONS

1. It is resolved to continue the same syllabi (Theory & Practical), model question paper & guide lines to be followed by the question paper setters of Botany of I semester of I B.Sc (B.Z.C, AQUA) under Choice Based Credit System (CBCS) approved by the Academic Council of 2021-22.
2. It is resolved to implement the syllabi (Theory & Practical), model question paper & guide lines to be followed by the question papers under Choice Based Credit System (CBCS) setters of Botany of III semesters of II B.Sc. (B.Z.C, AQUA) approved by the Academic Council of 2021 -22.
3. It is resolved to implement the same syllabi & model papers under Choice Based Credit System (CBCS) setters of Botany of V semesters of III B.Sc. (B.Z.C, AQUA) approved by the Academic Council of 2021-22.
4. It is resolved to continue the same Blue prints of I, III & V Semesters of B. Sc Botany for the Academic year 2021-22..
5. It is resolved to continue the following teaching and evolution methods for the Academic year 2021-22.
6. Any other matter.

Teaching methods:

- Besides the conventional methods of teaching, we use modern technology i.e. Using of OHP and LCD projector to display on U boards etc; for better understanding of concepts.

Evaluation of a student is done by the following procedure:

I. Internal Assessment Examinations:

- **Out of maximum 100 marks** in each paper for **II & III B.Sc** , **30 marks** shall be allocated for internal assessment.
- Out of these 30 marks, 20 marks are allocated for announced tests. Two announced tests will be conducted and average of these two tests shall be deemed as the marks obtained by the student, 5 marks are allocated on the basis of candidate's percentage of attendance, 5 marks for seminars / assignments for the III & V semesters.
- It is resolved to continue the same as approved by Academic Council in 2021-22.
- There is no pass minimum for internal assessment for I,II,III B.Sc
- **Out of maximum 100 marks** in each paper for **I B.Sc**, **25marks** shall be allocated for internal assessment.
- Out of these 25 marks, 20 marks are allocated for announced tests. Two announced tests will be conducted and average of these two tests shall be deemed as the marks obtained by the student, 5 marks are allocated on the basis of candidate's percentage of attendance / assignments for the I semester.

II. Semester-End Examinations:

- The maximum marks for I B.Sc (BZC, AQUA) Semester - End examinations shall be 75 marks and duration of the examination shall be 3 Hours.
- The maximum marks for II & III B.Sc (BZC, AQUA) Semester-End examinations shall be 70 marks and duration of the examination shall be 3 Hours. Even through the candidate is absent for two IA-EXAMS /obtain zero marks the external marks are consider (if the candidate gets 40/70) and the result shall be declared as "PASS"
- Semester-End examinations shall be conducted in theory papers at the end of every semester while in practical papers; these examinations are conducted at end of I, III, & V semesters.
- Discussed and recommended for organizing Seminars, Guest lectures, Work-shops to upgrade the Knowledge of students, for the approval of the Academic Council.

Note: Only for the semester I, we are following same syllabus, question paper, guidelines of P.B. Siddhartha degree college & SDMS Mahila kalasala .

Chairman

Course Structure of BZC, AQUA Syllabus

year	semester	Paper code	Title of the paper	Marks(100)		Credits
				Internal assessment	End semester	
I	I	BOTIIA	Fundamentals of Microbes and Non-vascular plants	25	75	4
			Practical-I	10	40	2
II	III	BOT-301	Anatomy of angiosperms, Plant Ecology and Biodiversity	30	70	3
			Practical-III	25	25	2
III	V	BOT-501	Cell Biology, Genetics and Plant Breeding.	30	70	3
			Practical-v – 501	15	35	2
III	V	BOT-502	Plant ecology and Phyto geography	30	70	3
			Practical-v- 502	15	35	2

A.G.& S.G. SIDDHARTHA DEGREE COLLEGE OF ARTS & SCIENCE

Vuyyuru- 521165.

NAAC reaccredited at 'A' level

Autonomous -ISO 9001 – 2015 Certified

Title of the Paper: Fundamentals of Microbes and Non-vascular Plants

Semester : I

Course Code	BOT11A	Course Delivery Method	Class Room / Blended Mode - Both
Credits	4	CIA Marks	25
No. of Lecture Hours / Week	4	Semester End Exam Marks	75
Total Number of Lecture Hours	60	Total Marks	100
Year of Introduction :	Year of Offering:	Year of Revision:	Percentage of Revision:

Learning Objectives:

On successful completion of this course, the students will be able to:

1. To understand origin of life on the earth and analyze structure, disease symptoms and transmission of plant viruses.
2. To understand the diversity and characteristics of Prokaryotes.
3. To understand the characteristics of Fungi and Lichens.
4. To understand the characteristics of Algae.
5. To understand the characteristics of Bryophyta.

PREREQUISITE

- Knowledge of microbes, thallophytes and Bryophytes at +2 level

COURSE OUTCOMES

By the end of the course students will be able to

CO 1	Explain origin of life on the earth.
CO 2	Illustrate diversity among the viruses and prokaryotic organisms and can categorize them.
CO 3	Analyze and ascertain the plant disease symptoms due to viruses, bacteria and fungi.
CO 4	Classify fungi, lichens, algae and bryophytes based on their structure, reproduction and life cycles.
CO 5	Evaluate the ecological and economic value of microbes, thallophytes and bryophytes.

SYLLABUS

UNIT – I	<p style="text-align: center;">Origin of life and viruses</p> <p>Origin of life, concept of primary Abiogenesis; Miller and Urey experiment. Five kingdoms classification of R.H. Whittaker. Discovery of microorganisms, Pasteur experiments, germ theory of diseases. Shape and symmetry of viruses; structure of TMV and Gemini virus; multiplication of TMV, a brief account of Prions and Viroids A general account on symptoms of plant diseases caused by Viruses. Transmission of plant viruses and their control. Significance of viruses in vaccine production, bio-pesticides</p>
UNIT – II	<p style="text-align: center;">Special groups of Bacteria and Eubacteria</p> <p>Brief account of Archaeobacteria, Actinomycetes and Cyanobacteria. Cell structure and nutrition of Eubacteria. Reproduction- Asexual (Binary fission and endospores) and bacterial recombination (Conjugation, Transformation, Transduction). Economic importance of Bacteria with reference to their role in Agriculture and industry (fermentation and medicine) A general account on symptoms of plant diseases caused by Bacteria; Citrus canker</p>
UNIT – III	<p style="text-align: center;">Fungi & Lichens</p> <p>General characteristics of fungi and Ainsworth classification (upto classes). Structure, reproduction and life history of (a) <i>Rhizopus</i> (Zygomycota) and (b) <i>Puccinia</i> (Basidiomycota). Economic uses of fungi in food industry, pharmacy and agriculture. A general account on symptoms of plant diseases caused by Fungi; Blast of Rice. Lichens- structure and reproduction.</p>
UNIT – IV	<p>General characteristics of Algae (pigments, flagella and reserve food material), Fritsch classification (upto classes). Thallus organization and life cycles in Algae. Occurrence, structure, reproduction and life cycle of a) <i>Spirogyra</i> (Chlorophyceae) and (b) <i>Polysiphonia</i> (Rhodophyceae). Economic importance of Algae</p>
UNIT – V	<p style="text-align: center;">Bryophytes</p> <p>5.1. General characteristics of Bryophytes; classification upto classes. 5.2. Occurrence, morphology, anatomy, reproduction (developmental details are not needed) and life cycle of (a) <i>Marchantia</i> (Hepaticopsida) and (b) <i>Fumaria</i> (Bryopsida). General account on evolution of sporophytes in Bryophyta</p>

Text books:

1. Botany – I (Vrukshasastram-I) : Telugu Akademi, Hyderabad
2. Pandey, B.P. (2013) *College Botany, Volume-I*, S. Chand Publishing, New Delhi

Books for Reference:

1. Prescott, L. Harley, J. and Klein, D. (2005)*Microbiology, 6th edition*, Tata McGraw –Hill Co. New Delhi.
2. Alexopoulos, C.J., C.W.Mims&M.Blackwell (2007) *Introductory Mycology*, Wiley& Sons, Inc., New York
3. Fritsch, F.E. (1945)*The Structure & Reproduction of Algae (Vol. I & Vol.II)*Cambridge University Press Cambridge, U.K..

A .G & S .G. SIDDHARTHA DEGREE COLLEGE OF ARTS AND SCIENCE, VUYYURU

(An Autonomous college in the jurisdiction of Krishna University)

MODEL QUESTION PAPER- Theory Examination(s) at Semester end 2021-2022

TITLE OF THE PAPER: Fundamentals of Microbes and Non-vascular Plants (Viruses, Bacteria, Fungi, Lichens, Algae and Bryophytes)

Course Code: BOTT11A

Max. Time: 3 Hrs.

Max. Marks: 75 M

SECTION – A

**Answer FIVE of the following questions. Draw labelled diagrams wherever necessary. 5 x 5=25M
ONE question should be given from each Unit in the syllabus.**

1. Five kingdom classification of Whittaker **CO1-L2**
2. Germ theory of diseases **CO1-L2**
3. Which groups of organisms are once considered as algae? Give an account of general characters of that group **CO2- L1**
4. What are the symptoms of citrus canker? Mention the causal organism of citrus canker. **CO2- L2.**
5. Ainsworth classification of fungi **CO-3 L2**
6. Why lichens are considered as unique and composite organisms? **CO-3 L1**
Why diplobiontic life cycle is called so? Mention an alga that shows diplobiontic life cycle. List out the phases exhibited in one such life cycle studied by you. **CO-4 L1**
8. Vegetative reproduction in Bryophytes. **CO5-L2**

SECTION – B

Answer the following questions.

5x10= 50 M

Two questions (A & B) are to be given from each Unit in the syllabus (internal choice in each unit). Student has to answer 5 questions by choosing one from a set of questions given from a Unit.

- 9 a) Give an account of structure and multiplication of TMV? **CO1- L2**
OR
b) Explain the significance of viruses in vaccine production, bio-pesticides . **CO1-L2**
10. a) Whether bacteria exhibit sexual reproduction or not ? Elucidate different methods of bacterial recombination. **CO2- L2**
OR
b) Explain the role of bacteria in agriculture and industry . **CO2- L2**
- 11 a) Why *Puccinia* is called as macro cyclic rust? Explain the stages of the fungus on Primary host. **CO3-L1.**
OR
b) Why lichens are considered as 'pioneers of colonization'? Write about reproduction in Lichens. **CO3-L1**
- 12 a). What is thallus? Describe various types of thalli found in algae. **CO4-L2**
OR
b) Explain life cycle of *Spirogyra* . **CO-4 L2**
13. a) Describe morphological and anatomical features of *Marchantia*. **CO5- L2**
OR
b) What is the dominant phase in the life cycle of bryophytes?
Give account on of sporophyte evolution in Bryophytes. **CO5-L 2**

A .G & S .G. SIDDHARTHA DEGREE COLLEGE OF ARTS AND SCIENCE, VUYURU

(An Autonomous college in the jurisdiction of Krishna University)

Practical Syllabus

SEMESTER- I

PAPER- I

CREDITS : 02

BOTANY	BOTT11A	WEF: 2021-2022	B. Sc (BZC), AQUA
---------------	----------------	-----------------------	--------------------------

Title of the paper: Fundamentals of Microbes and Non-vascular Plants

(Viruses, Bacteria, Fungi, Lichens, Algae and Bryophytes)

NO OF HOURS: 30

Learning outcomes: On successful completion of this practical course, student shall be able to

- Demonstrate the techniques of use of lab equipment, preparing slides and identify the material and draw diagrams exactly as it appears.
- Observe and identify microbes and lower groups of plants on their own.
- Demonstrate the techniques of inoculation, preparation of media etc.
- Identify the material in the permanent slides etc.

Practical Syllabus:

1. Knowledge of Microbiology laboratory practices and safety rules.
2. Knowledge of different equipment for Microbiology laboratory (Spirit lamp, Inoculation loop, Hot-air oven, Autoclave/Pressure cooker, Laminar air flow chamber and Incubator) and their working principles. (In case of the non- availability of the laboratory equipment the students can be taken to the local college/clinical lab. with required infrastructural facilities or they can enter a linkage with the college/lab for future developments and it will fetch credits during the accreditation by NAAC).
3. Demonstration of Gram's staining technique for Bacteria.
4. Study of Viruses (Corona, Gemini and TMV) using electron micrographs/ models.
5. Study of Archaeobacteria and Actinomycetes using permanent slides/ electron micrographs/diagrams.
6. Study of *Anabaena* and *Oscillatoria* using permanent/temporary slides.
7. Study of different bacteria (Cocci, Bacillus, Vibrio and Spirillum) using permanent or temporary slides/ electron micrographs/ diagrams.
8. Study/ microscopic observation of vegetative, sectional/anatomical and reproductive structures of the following using temporary or permanent slides/ specimens/ mounts
 - a. Fungi : *Rhizopus*, *Penicillium* and *Puccinia*.
 - b. Lichens: Crustose, foliose and fruticose

c. Algae : *Volvox*, *Spirogyra*, *Ectocarpus* and *Polysiphonia*

d. Bryophyta : *Marchantia* and *Funaria*

9. Study of specimens of Tobacco mosaic disease, Citrus canker and Blast of Rice.

Suggested Manuals:

1. Vasista, B.R. (2018). Botany for degree students - Algae - S. Chand and company Ltd., New Delhi.

2. Dubey, H.C (2018). A text book of Fungi, bacteria and Viruses. Vikas publishing House, New Delhi.

3. Smith, G.M (1955). Cryptogamic Botany (Vol. I Algae, Fungi, & Lichens)

McGraw-Hill Book Co., New York

A .G & S .G. SIDDHARTHA DEGREE COLLEGE OF ARTS AND SCIENCE, VUYURU

(An Autonomous college in the jurisdiction of Krishna University)

MODEL QUESTION PAPER FOR PRACTICAL EXAMINATION

Semester – I/ Botany Core Course – I

**TITLE OF THE PAPER: Fundamentals of Microbes and Non-vascular Plants
(Viruses, Bacteria, Fungi, Lichens, Algae and Bryophytes)**

Max. Time: 3 Hrs.

Max. Marks: 40

-
1. Take the T.S. of material 'A' (Fungi), make a temporary mount and make comments about identification. 8M
 2. Identify any 2 algae from the mixture (material 'B') given with specific comments about identification. 8M
 3. Take the T.S. of material 'C' (Bryophyta), make a temporary mount and make comments about identification. 8M
 4. Identify the following with specific reasons 4x2=8M
 - A. A laboratory equipment of Microbiology
 - B. B. Virus
 - C. Archaeobacteria /Ascomycete /Cyanobacteria/ Eu-Bacteria
 - D. Lichen
 5. Record + Viva-voce 5+3 = 8 M

A.G.& S.G. SIDDHARTHA DEGREE COLLEGE OF ARTS & SCIENCE

Vuyyuru - 521165.

NAAC reaccruited at 'A' level

Autonomous -ISO 9001 – 2015 Certified

Title of the Paper: Anatomy and Embryology of Angiosperms, Plant Ecology and Biodiversity

Semester: III

Course Code	BOT301C	Course Delivery Method	Class Room / Blended Mode - Both
Credits	3	CIA Marks	30
No. of Lecture Hours / Week	4	Semester End Exam Marks	70
Total Number of Lecture Hours	60	Total Marks	100
Year of Introduction :2017-18	Year of Offering: 2021 - 22	Year of Revision:2021 - 22	Percentage of Revision: 50 %

Learning Objectives:

On successful completion of this course, the students will be able to:

1. To understand Anatomy of Angiosperms - organization of tissues and tissue systems in plants..
2. To understand the various aspects of embryology.
3. To understand the basic concepts of plant ecology.
4. To understand the various parameters of population and community ecology.
5. To understand the importance of biodiversity

THEORY: Learning outcomes:

- On successful completion of this course, the students will be able to;
 - Understand on the organization of tissues and tissue systems in plants.
 - Illustrate and interpret various aspects of embryology.
 - Discuss the basic concepts of plant ecology, and evaluate the effects of environmental and biotic factors on plant communities.
 - Appraise various qualitative and quantitative parameters to study the population and community ecology.
 - Correlate the importance of biodiversity and consequences due to its loss.
 - Enlist the endemic/endangered flora and fauna from two biodiversity hot spots in India and assess strategies for their conservation.
-

SYLLABUS

Unit – 1	Anatomy of Angiosperms
	<p>Organization of apical meristems: Tunica-carpus theory and Histogen theory. Tissue systems–Epidermal, ground and vascular. Anomalous secondary growth in <i>Boerhaavia</i> and <i>Dracaena</i>. Study of timbers of economic importance - Teak, Red sanders and Rosewood.</p>
Unit – 2	Embryology of Angiosperms
	<p>Structure of anther, anther wall, types of tapetum. Microsporogenesis and development of male gametophyte. Structure of ovule, megasporogenesis; monosporic (<i>Polygonum</i>), bisporic (<i>Allium</i>) and tetrasporic (<i>Peperomia</i>) types of embryo sacs. Outlines of pollination, pollen – pistil interaction and fertilization. Endosperm - Types and biological importance - Free nuclear, cellular, helobial and ruminant. Development of Dicot (<i>Capsella bursa-pastoris</i>) embryo.</p>
Unit – 3	Basics of Ecology
	<p>Ecology: definition, branches and significance of ecology. Ecosystem: Concept and components, energy flow, food chain, food web, ecological pyramids. Plants and environment: Climatic (light and temperature), edaphic and biotic factors. Ecological succession: Hydrosere and Xerosere.</p>
Unit – 4	Population, Community and Production Ecology
	<p>Population ecology: Natality, mortality, growth curves, ecotypes, ecads Community ecology: Frequency, density, cover, life forms, biological spectrum Concepts of productivity: GPP, NPP and Community Respiration Secondary production, P/R ratio and Ecosystems</p>
Unit – 5	Basics of Biodiversity
	<p>Biodiversity: Basic concepts, Convention on Biodiversity - Earth Summit. Value of Biodiversity; types and levels of biodiversity and Threats to biodiversity Biodiversity Hot spots in India. Biodiversity in North Eastern Himalayas and Western Ghats. Principles of conservation: IUCN threat-categories, RED data book Role of NBPGR and NBA in the conservation of Biodiversity.</p>

Text books:

1. Botany – III (Vrukshasastram-I) : Telugu Akademi, Hyderabad
2. Botany – IV (Vrukshasastram-II) : Telugu Akademi, Hyderabad
3. Pandey, B.P. (2013) *College Botany, Volume-II*, S. Chand Publishing, New Delhi

Books for Reference:

- Esau, K. (1971) *Anatomy of Seed Plants*. John Wiley and Son, USA.
- Paula Rudall (1987) *Anatomy of Flowering Plants: An Introduction to Structure and Development*. Cambridge University Press, London
- Bhojwani, S. S. and S. P. Bhatnagar (2000) *The Embryology of Angiosperms (4th Ed.)*, Vikas Publishing House, Delhi.

A.G & S.G. Siddhartha Degree College of Arts & Science

An autonomous college in the jurisdiction of Krishna University

BOTANY	BOT- 301C	w.e.f. 2021-22	B. Sc. (BZC), AQUA
--------	-----------	----------------	--------------------

II B. Sc – BOTANY

Model Question Paper

SEMESTER- III

PAPER-III: Anatomy and Embryology of Angiosperms, Plant Ecology and Biodiversity

Time: 3 Hours

Max. Marks: 70

SECTION-A

Answer any **four** of the following questions.

4x 5 = 20Marks

(Draw diagrams wherever necessary)

1. Histogen theory.
2. Rosewood.
3. Ruminant endosperm
4. Energy flow
5. Significance of ecology.
6. Natality
7. GPP.
8. NBPGR

SECTION-B

Answer any **five** of the following questions.

5x10 = 50Marks

(Draw diagrams wherever necessary)

9. Explain about Organization of apical meristems:
10. Describe the Anomalous secondary growth in *Boerhaavia*?
11. Write an essay on ICBN.
12. Describe vegetative & floral characters of Asclepiadaceae.
13. Write an essay on ecological pyramids?
14. What is Ecological succession: Write an essay on Hydrosere?
15. Write the characteristics of population ecology?
16. Give an account of Value of Biodiversity?

Guide lines for paper setter: (for Paper III – BOT- 301) w.e.f 2021-22

1. In **section A**: Unit II, V must carry **one** question, Unit I,III & IV must carry **two** questions.
2. In **section- B**: Set minimum **two** questions from Unit I, II, III . **One** question each from Unit IV and Unit V.
3. See the following table and Model paper for marks distribution.
4. Please provide the scheme of valuation for the paper.
5. Question paper should be both in English and Telugu media.

Unit	Section - A		Section - B		Weightage in
	Questions	Marks	Questions	Marks	Marks
Unit – I	2		2		
		10		20	30
Unit - II	1		2		
		05		20	25
Unit – III	2		2		
		10		20	30
Unit – IV	2		1		
		10		10	20
Unit – V	1		1		
		05		10	15
Max. Q & marks	8	(x 5) = 40	8	(x 10) = 80	(Total questions =16) Total marks = 120
Max. Q and marks for Valuation	Questions	Marks	Questions	Marks	Max. marks
	4	(4 X 5M) = 20 M	5	(5 X 10M)= 50 M	70M

INTERNAL EXAMS - 30Marks

(20 marks for unit tests, 5marks for Attendance **5** marks for seminars)

Practical syllabus of Botany Core Course – 3 /Semester – III

Anatomy and Embryology of Angiosperms, Plant Ecology and Biodiversity

(Total hours of laboratory exercises 30 Hrs. @ 02 Hrs./Week)

Course Outcomes:

On successful completion of this practical course students shall be able to:

1. Get familiarized with techniques of section making, staining and microscopic study of vegetative, anatomical and reproductive structure of plants.
2. Observe externally and under microscope, identify and draw exact diagrams of the material in the lab.
3. Demonstrate application of methods in plant ecology and conservation of biodiversity and qualitative and quantitative aspects related to populations and communities of plants.

Practical Syllabus

1. Tissue organization in root and shoot apices using permanent slides.
2. Anomalous secondary growth in stems of *Boerhavia* and *Dracaena*.
3. Study of anther and ovule using permanent slides/photographs.
4. Study of pollen germination and pollen viability.
5. Dissection and observation of Embryo sac haustoria in *Santalum* or *Argemone*.
6. Structure of endosperm (nuclear and cellular) using permanent slides / Photographs.
7. Dissection and observation of Endosperm haustoria in *Crotalaria* or *Coccinia*.
8. Developmental stages of dicot and monocot embryos using permanent slides / photographs.
9. Study of instruments used to measure microclimatic variables; soil thermometer, maximum and minimum thermometer, anemometer, rain gauge, and lux meter. (visit to the nearest/local meteorology station where the data is being collected regularly and record the field visit summary for the submission in the practical).
10. Study of morphological and anatomical adaptations of hydrophytes and xerophytes (02 each).
11. Quantitative analysis of herbaceous vegetation in the college campus for frequency, density and abundance.
12. Identification of vegetation/various plants in college campus and comparison with Raunkiaer's frequency distribution law.
13. Find out the alpha-diversity of plants in the area.
14. Mapping of biodiversity hotspots of the world and India

Model paper for Practical Examination

Semester – III/ Botany Core Course – 3

Anatomy and Embryology of Angiosperms, Plant Ecology and Biodiversity

Max. Time: 3 Hrs.

Max. Marks: 50

1. Take T.S. of the material 'A' (Anatomy), prepare a temporary slide and justify the identification with specific reasons. 7M
2. Write the procedure for the experiment 'B' (Embryology) and demonstrate the same. 6M
3. Take T.S. of the material 'C', prepare a temporary slide and justify the identification with specific reasons.
4M
4. Identify the following with specific reasons. 4 x 2 = 8 M
D. Anatomy/Embryology
E. Ecology instrument
F. Mapping of Biodiversity hot spot
G. Endemic/endangered plant/animal

Total Marks: 25

Internals:

1. Record 10M
2. Viva-voce3M
3. Field trip4M
4. Internal practical exam 8M

Total Marks:25

Total marks: 50

Suggested co-curricular activities for Botany Core Course-3 in Semester-III:

A. Measurable :

a. Student seminars :

1. Anatomy in relation to taxonomy of Angiosperms.
2. Nodal anatomy
3. Floral anatomy
4. Embryology in relation to taxonomy of Angiosperms.
5. Apomictics and polyembryony.
6. Biogeochemical cycles- Carbon, Nitrogen and Phosphorous.
7. Deforestation and Afforestation.
8. Green house effect and ocean acidification.
9. The Montreal protocol and the Kyoto protocol.
10. Productivity of aquatic ecosystems.
11. Mangrove ecosystems in India.
12. Kollerulake – Ramsar site.
13. Biodiversity hotspots of the world.
14. Origin of Crop plants - Vavilov centers
15. Agrobiodiversity
16. International organizations working on conservation of Biodiversity
17. Nagoya protocol – ABS system.
18. Endemic and endangered plants in Andhra Pradesh.

b. Student Study Projects :

1. Stomata structure in plants from college campus/ their native place.
2. Report on xylem elements in plants using maceration technique.
3. Collection of information on famous herbaria in the world and preparation of a report.
4. Microscopic observations on pollen morphology from plants in college Campus/ their native locality.
5. Study report on germination and viability of pollen in different plants.
6. Observation of anthesis time in different plants and their pollinators.
7. A report on autecology and synecology of some plants in college campus or their native place.
8. Collection of photos of endemic/endangered plant and animal species to Make an album.

9. Biodiversity of the college or their own residential/ native area.
10. Collection of seeds/vegetative organs of rare plant species from their localities and to raise/grow in college garden

C .Assignments: Written assignment at home / during 'O' hour at college; preparation of charts with drawings, making models etc., on topics included in syllabus.

B. General :

1. Visit to an arboretum/silviculture station/Forest research institute to see the live timber yielding plants or to visit a local timber depot. to observe various woods.
2. Field visit to a nearby ecosystem to observe the abiotic-biotic relationships.
3. Visit to National park/Sanctuary/Biosphere reserve etc., to observe in-situ conservation of plants and animals.
4. Visit to a Botanical garden or Zoo to learn about ex-situ conservation of rare plants or animals.
5. Group Discussion (GD)/ Quiz/ Just A Minute (JAM) on different modules in syllabus of the course.

A.G.& S.G. SIDDHARTHA DEGREE COLLEGE OF ARTS & SCIENCE

Vuyyuru - 521165.

NAAC reaccredited at 'A' level

Autonomous -ISO 9001 – 2015 Certified

Title of the Paper: Cell Biology, Genetics and Plant Breeding

Semester : V

Course Code	BOT-501	Course Delivery Method	Class Room / Blended Mode - Both
Credits	3	CIA Marks	30
No. of Lecture Hours / Week	4	Semester End Exam Marks	70
Total Number of Lecture Hours	60	Total Marks	100
Year of Introduction :2017-18	Year of Offering: 2017 - 18 2021-22	Year of Revision:2021 - 22 2021-22	Percentage of Revision: 50 %

Learning Objectives:

On successful completion of this course, the students will be able to:

1. To understand the Cell, Structure and functions
2. To understand the Genetic Material
3. To understand the basic concepts of plant ecology.
4. To understand the various parameters of population and community ecology.
5. To understand the importance of biodiversity

SYLLABUS

UNIT-I	Cell Biology Cell, Ultra Structure and functions of cell wall. Molecular Organization of cell membranes. Chromosomes; morphology, organization of DNA in a chromosome (Nucleosome model) Euchromatin and Heterochromatin.
UNIT-II	Genetic Material DNA as the Genetic Material: Griffith's and Avery's Transformation Experiment. Hershey - Chase Bacteriophage experiment. DNA Structure (Watson & crick model) and replication of DNA (SemiConservative). Types of RNA (mRNA, tRNA, rRNA), their structure and function.
UNIT- III	Mendelian Inheritance Mendelian Inheritance (Mono – Di-hybrid Crosses), Back cross and Text cross. Linkage: concept, complete and In-complete Linkage, Coupling and Repulsion; Linkage Maps Based on Two and Three Point cross. Crossing over concept and significance.
UNIT-IV	Gene Expression Organization of gene, Transcription and Translation. Mechanism and regulation of Gene Expression in Prokaryotes (Lac operon). Mutations: Chromosomal Aberrations, Gene Mutations and Transposable Elements
UNIT-V	Plant Breeding Introduction and objectives of Plant Breeding. Methods of Crop Improvement: Procedure, Advantages and limitations of Introduction, Selection and Hybridization (Out lines only).

B.Sc – BOTANY
SEMESTER -V. THEORY MODEL PAPER

Time: 3 Hours

Max. Marks: 70

SECTION-A

Answer any FOUR of the following question
(Draw diagrams wherever necessary)

4 x 5=20M.

1. Nucleosome
2. Griffith experiment.
3. tRNA
4. Back cross and test cross.
5. Transcription.
6. Three point test cross.
7. Hybridization.
8. Crossing over.

SECTION-B

Answer any FIVE of the following questions.
(Draw diagrams wherever necessary)

5 x 10 = 50M.

9. Describe the Ultra structure and functions of cell membrane.
10. What is cell theory? Write about eukaryotic cell components.
11. Write about structure and replication of DNA.
12. DNA as a genetic material proof with suitable experiments.
13. Explain the Mendel's law of inheritance.
14. Define linkage. Describe the different types of Linkage.
15. Write an essay on mechanism and Regulation of gene Expression in Prokaryotes.
16. Discuss about methods of Crop improvement.

Guide lines for paper setter: (for Paper V-BOT-501) W.e.f. 2021-22

1. In Section A: Unit I, III, V must carry one question from each unit. Unit II must carry 2 questions and Unit IV must carry three questions.
2. In section-B: Set minimum Two questions from Unit I, II & III
3. See the following table and Model paper.
4. Please provide the scheme of valuation for the paper.
5. Question paper should be both in English and Telugu media.

Unit	Section - A		Section - B		Weightage in Marks
	Questions	Marks	Questions	Marks	
Unit – I	1		2		
		5	20		25
Unit – II	2		2		
		10	20		30
Unit –III	1		2		
		5		20	25
Unit-IV	3		1		
		15		10	25
Unit-V	1		1		
		5		10	15
Max .Q & marks	8	(x 5) =40	8	(x 10) = 80	(Total questions =16) Marks 120
Max. Q and marks for Valuation	Questions	Marks	Questions	Marks	Max. marks
	4		5		
		(4 x 5) = 20		(5 x 10) = 50	70

INTERNAL EXAMS - 30Marks

(20 marks for unit tests, 5marks for Attendance 5 marks for seminars)

III B.SC-BOTANY Practical paper
Cell Biology, Genetics and Plant Breeding

SEMESTER-V

BOT-501-P

Time: 3hr

Total hours of teaching 30hrs @ 2 hrs per week

Max.marks:50

1. Study of the structure of cell organelles through photomicrographs.
2. Study of plant cell through temporary mounts.
3. Study of various stages of mitosis using cytological preparation of Onion root tips.
4. Study of DNA packing by micrographs.
5. Numerical problems solving Mendal's Laws of inheritance.
6. Chromosome mapping using 3 point test cross data.
7. Hybridization techniques –emasulation. Bagging (for demonstration only).
8. Field visit to a plant breeding research station.

III B.SC-SEMESTER-V, BOTANY PRACTICAL MODEL PAPER

PAPER –V: CELL BIOLOGY GENETICS AND PLANT BREEDING

1. Perform the Experiment A Squash technique.....12M
2. Give the experimental protocol of the experiments. B.....04M
3. Solving numerical problems on Mendelian inheritance....C, D..... $2 \times 7 \frac{1}{2} = 15$ M
4. Record.....05M
- Viva.....04M
- Internal Practical Exam.....10M

III B.SC-BOTANY Syllabus SEMESTER-V

Practical paper – V: Cell Biology, Genetics and Plant Breeding

Total hours of teaching 30hrs @ 2 hrs per week

1. Perform the Experiment A.

Squash technique	4M
Procedure.....	4M
diagram	2M =10

2. Give the experimental protocol of the experiments. B.....4M

3. Genetic problem C, D

Salvation of problem.....	5M
Reasoning.....	2\2M
	2X71\2=15M

Viva

4M

Internal:

a) Record.....	5 M.
b)Internal Practical Exam.....	10M

Books for Reference:

1. Old, R.W. and Primrose S.B. 1994, Principles of Gene Manipulation Blackwell Science, 19 London 2. Grierson, D. and Convey S.N. 1989, Plant Molecular Biology, Blackie Publishers, New York.
2. Lea, P.J. and Leegood R.C. 1999, Plant Biochemistry and Molecular Biology, John Wiley and Sons, London.
3. Power C.B., 1984, Cell Biology, Himalaya Publishing Co. Mumbai
4. De. Robertis and De Robertis, 1998, Cell and Moleceular Biology, K.M. Verghese and Company .

A.G.& S.G. SIDDHARTHA DEGREE COLLEGE OF ARTS & SCIENCE

Vuyyuru - 521165.

NAAC recredited at 'A' level

Autonomous -ISO 9001 – 2015 Certified

Title of the Paper: PLANT ECOLOGY & PHYTOGEOGRAPHY

Semester : V

Course Code	BOT-502	Course Delivery Method	Class Room / Blended Mode - Both
Credits	3	CIA Marks	30
No. of Lecture Hours / Week	4	Semester End Exam Marks	70
Total Number of Lecture Hours	60	Total Marks	100
Year of Introduction :2017-18	Year of Offering: 2017 - 18 2021-22	Year of Revision:2021 - 22 2021-22	Percentage of Revision: 50 %

Learning Objectives:

On successful completion of this course, the students will be able to:

1. To understand the elements of ecology.
2. To understand the ecosystem
3. To understand the basic concepts of plant ecology.
4. To understand the various parameters of population and community ecology.
5. To understand the importance of biodiversity

SYLLABUS

UNIT-I	<p>ELEMENTS OF ECOLOGY</p> <p>Ecology: Definition, branches and significance of ecology. Claimatic factors: Light, Temperature. Edaphic factor: Origin, formation, composition and soil profile. Biotic factor, Ecological adaptations of Plants.</p>
Unit- II	<p>Ecosystem Ecology</p> <p>Ecosystem: concept and components, energy flow, food chain, food web, Ecological Pyramids. Productivity of ecosystem-Primary, Secondary and Net productivity. Biogeochemical cycles- Carbon, Nitrogen and Phosphorous.</p>
Unit – III	<p>Population & Community ecology</p> <p>Population- defination, characteristics and importance (Density, Natality, Mortality, Growth Curves) outlines- ecotypes. Plant communities- characters of a community, outlines – Frequency, density, cover, life forms, Biological Spectrum. Ecological Succession: Hydrosere and Xerosere.</p>
Unit-IV	<p>Phytogeography</p> <p>Principles of Phytogeography, Distribution (Wides, Endemic, Discontinuous species). Phytogeography regions of India. Endemism – types and Causes.</p>
Unit-V	<p>Plant Biodiversity and its Importance</p> <p>Definition, Levels of Biodiversity – genetic, species and ecosystem. Biodiversity and Hot-spots of India: North Eastern, Himalayas and Western Ghats. Loss of Biodiversity-causes and Conservation (In-situ and Ex-Situ Methods).</p>

B.Sc – BOTANY

SEMESTER –VI THEORY MODEL PAPER

PLANT ECOLOGY & PHYTOGEOGRAPHY

Time: 3 Hours

Max. Marks: 70

SECTION-A

Answer any FOUR of the following question.

4 x 5= 20M.

(Draw diagrams wherever necessary)

1. Soil profile.
2. Biotic factor.
3. Food web.
4. Energy Flow in Ecosystem.
5. Natality.
6. Biological Spectrum
7. Endemism.
8. Red-Data book.

SECTION-B

Answer any Five of the following questions.

5 x 10 = 50M.

(Draw diagrams wherever necessary)

9. Discusses the importance of Temperature Factor on Plant Growth.
10. Briefly Discuss the Ecological Adaptations of Xerophytes.
11. What are Ecological Pyramids? Describe the Pyramids of numbers, Biomass and Energy.
12. What are biogeochemical cycles? Give an account of Nitrogen cycle?
13. What is Plant Succession? Describe Hydrosere?
14. What are the Characters of Plant Communities?
15. What are Principles of Plant Phytogeography?
16. What is Biodiversity? Explain the Levels of Biodiversity.

Guide lines for paper setter: (for Paper V-BOT-502) W.e.f. 2021-22

1. In Section A: Unit I, II, III, must carry Two question from each unit. Unit IV, V must carry one question.
2. In section-B: Set minimum two questions from Unit I, II & III and Set One Question from IV, V.
3. See the following table and Model paper.
4. Please provide the scheme of valuation for the paper.
5. Question paper should be both in English and Telugu media.

Unit	Section – A		Section - B		Weightage in
	Questions	Marks	Questions	Marks	Marks
Unit – I	2		2		
	10		20		30
Unit – II	2		2		
	10		20		30
Unit – III	2		2		
	10		20		30
Unit-IV	1		1		
	5		10		15
Unit-V	1		1		
	5		10		15
Max. Q & marks	8 (x 5) = 40		8 (x 10) = 80		(Total questions = 16) Marks 120
Max. Q and marks for Valuation	Questions	Marks	Questions	Mark s	Max. marks
	4		5		
	(4 x 5) = 20		(5 x 10) = 50		70

INTERNAL EXAMS – 30 Marks

(20 marks for unit tests, 5 marks for assignments and remaining 5 marks for seminar etc.)

BOTANY PRACTICAL
PLANT ECOLOGY & PHYTOGEOGRAPHY

SEMESTER- V

BOT-502-P

Total hours of teaching 30 hrs @ 3 hrs per week

1. Study of instruments used to measure microclimatic variables; soil thermometer, maximum and minimum thermometer, anemometer, psychomotor, rain gauze, and lux meter.
2. Permeability (percolation; total capacity as well as rate of movement) of different soil samples.
3. Determination of soil pH
4. Study of morphological and anatomical adaptations of hydrophytes and xerophytes. (4each)
5. Determination of minimal quadrat size for the study of herbaceous vegetation in the college campus by species area curve method.
6. Study of Phytoplankton and macrophytes from water bodies.
7. Study of species diversity index of vegetation.
8. Estimation of Primary Productivity of an ecosystem.
9. To study field vegetation with respect to stratification, canopy cover and composition.
10. Study of plants included in agro forestry and social forestry.
11. To locate the hotspots, phyto geographical regions and distribution of endemic plants in the map of India.
12. The following practical should be conducted in the Field/lab with the help of Photographs, herbarium, Floras, Red data book- Study of endangered plants species, critically endangered plants species, vulnerable plant species and monotypic endemic genera of India.

BOTANY PRACTICAL
PLANT ECOLOGY & PHYTOGEOGRAPHY

SEMESTER- V

BOT-502-P

Total hours of teaching 30 hrs @ 3 hrs per week

1. Study Project under supervision.....12 Marks
2. Experiment A 07Marks
3. Anatomical adaptations of **B** (Section cutting)..... 07Marks
4. Spotters **C&D**(2x2 1/2) = 5 Marks
5. Record.....05Marks
6. Viva-Voc.....04Mrks
7. Internal practical exam.....10Marks

Total = 50 Marks

BOTANY PRACTICAL
PLANT ECOLOGY & PHYTOGEOGRAPHY

SEMESTER- V

BOT-502-P

Scheme of Valuation

1. Study Project under supervision
To study Honey Bees and Plants Yielding Honey 12 Marks
2. Experiment A -determination of soil porosity/PH..... 07Marks
3. Anatomical adaptations of **B** (Section cutting)
Xerophytes / Hydrophytes07Marks
4. Spotters **C&D** anemometer/rain gauze/lux meter (2x2 1/2) = 5 Marks
5. Viva-Voc.....04Mrks
6. Record..... 05Marks
7. Internal practical exam..... 10Marks

Total = 50 Marks

Books for Reference:

1. Daubenmire, R.F. (): Plants & Environment (2nd Edn.,) John Wiley & Sons.,
New York22
2. Puri, .G.S. (1960): Indian Forest Ecology (Vol.I & II) Oxford Book Co., New Delhi
&Calcutta.
3. Billings, W.B. (1965): Plants and the Ecosystem Wadsworth Publishing Co., Inc.,
Belmont.
4. Misra, R. (1968): The Ecology work Book Oxford & INH Publishing Co., Calcutta

**A.G& S.G.SIDDHARTHA DEGREE COLLEGE OF ARTS &
SCIENCE**

VUYYURU-521165, KRISHNA Dt., A.P.(Autonomous)

Accredited by NAAC with "A" Grade

2021-2022



DEPARTMENT OF BOTANY



MINUTES OF BOARD OF STUDIES



EVEN SEMESTER

04-04-2021

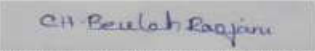
Minutes of the meeting of Board of studies in Botany for the Autonomous courses of AG & SG Siddhartha Degree College of Arts & Science, Vuyyuru, held at 10:30 A.M on 04-04-2022 in the Department of Botany through online.

Members Present:-

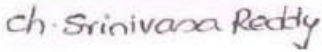
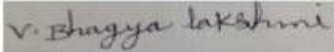
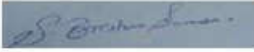
- 1) .....Chairman
(Smt. CH. Beulah Ranjani) Head, Department of Botany
A. G & S.G S Degree College of
Arts & Science Vuyyuru- 521165.
- 2) .....University
(Sri. Dr. K. Ramesh) Nominee Department of Botany &
Head (I/c) Botany,

The Hindu College, Guntur .
- 3) .....Academic
(Sri. Dr. Ch. Srinivasa Reddy) Council Nominee Lecture in Botany,
SRR& CVR Govt. Degree College
Vijayawada, 520004
- 4) .....Academic
(Smt. V. Bhagya Lakshmi) Council Nominee Head, Department of Botany
SDMSK, Vijayawada,
- 4) .....Industrialist. Natural farming.
(Sri. S. Krishna Suman) yakamuru
Vuyyuru, Krishna d.t
- 5) .....Member
(Sri. N. Ramana Rao) Ad hoc Lecturer in Botany
AG & SGS Degree College of
Arts & Science (Autonomous),

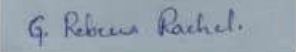
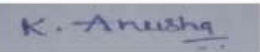
Vuyyuru-521165.
- 6) .....Member
(Ms. G. Rebecca Rachel) Ad hoc Lecturer in Botany
AG & SGS Degree College of Arts &
Science (Autonomous), Vuyyuru-521165.
- 7) .....student representative
(Ms K. Anusha MSc) Lecturer in chaitanya
Gudiwada

Agenda for B.O.S Meeting.

1. To recommend the syllabi (Theory & Practical), Model question paper for II Semester of I B.Sc (A.B.C) for the academic year 2021-2022.
2. To recommend the syllabi (Theory & Practical), Model question paper for IV Semester of II B.Sc (A.B.C) for the academic year 2021-2022.
3. To recommend the syllabi (Theory & Practical), Model question paper for VI Semester of III B.Sc (A.B.C) for the academic year 2021-2022.
4. To recommend the syllabi (Theory & Practical), Model question paper and Blue print of II, IV & VI semester of I, II, III B.Sc (A.B.C.) for the academic year 2021-2022.
5. To recommend the teaching and evolution methods to be followed under Autonomous status.
6. Any other matter.

Dr. Anilakrishnan
Chairman.

RESOLUTIONS

1. It is resolved to continue the same syllabi (Theory & Practical), model question paper & guide lines to be followed by the question paper setters of Botany of II semester of I B.Sc. (B.Z.C) under Choice Based Credit System (CBCS) approved by the Academic Council of 2021 – 2022.
2. It is resolved to implement the syllabi (Theory & Practical), model question paper & guide lines to be followed by the question papers under Choice Based Credit System (CBCS) setters of Botany of IV Semester of II B.Sc. (B.Z.C) approved by the Academic Council of 2021 –2022.
3. It is resolved to implement the same syllabi & model papers under Choice Based Credit System (CBCS) Setters of Botany of VI semester of III B.Sc. (B.Z.C) approved by the Academic Council of 2021-2022.
4. It is resolved to Continue the same Blue prints of I,IV, &VI Semesters of B.Sc Botany for the Academic year 2021-2022.
5. It is resolved to continue the following teaching & evolution methods for the Academic year 2021-22.
6. Any other matter.

Teaching methods:

Besides the conventional methods of teaching, we use modern technology i.e. Using of OHP and LCD projector to display on U boards etc; for better understanding of concepts.

Evaluation of a student is done by the following procedure:

• Internal Assessment Examination:

- Out of maximum 100 marks in each paper for II, III B.Sc, 30 marks shall be allocated for internal assessment.
- Out of these 30 marks, 20 marks are allocated for announced tests (i.e . IA-1& IA-2). Two announced tests will be conducted and average of these two tests shall be deemed as the marks obtained by the student, 5 marks are allocated on the basis of candidate's percentage of attendance and remaining 5 marks are allocated for the assignment for II, III B.SC.
- Out of maximum 100 marks in each paper for II B.Sc, 25 marks shall be allocated for internal assessment.
- Out of these 25 marks, 15 marks are allocated for announced tests (i.e. IA-1& IA-2). Two announced tests will be conducted and average of these two tests shall be deemed as the marks obtained by the student, 5 marks allocated on the basis of candidate's percentage of attendance / assignment for II semester.
- There is no pass minimum for internal assessment for I, II, III B.Sc

• Semester – End Examination:

- The maximum mark for II (BZC) semester – End examination shall be 75 marks and duration of the examination shall be 3 hours.
- The maximum mark for II, III B.Sc semester- End examination shall be 70 marks and duration of the examination shall be 3 hours. Even through the candidate is absent for two IA exams / obtain zero marks the external marks are considered (if the candidate gets 40/70) and the result shall be declared as "PASS"
- Semester – End examination shall be conducted in theory papers at the end of every semester, while in practical papers, these examinations are conducted at the end of I, IV, & VI semester for I, II & III B.Sc.
- Discussed and recommended for organizing Seminars, Guest lectures, Work – Shops to upgrade the Knowledge of students, for the approval of the Academic Council.

Course Structure of BZC, AQUA Syllabus

year	semester	Paper code	Title of the paper	Marks(100)		Credits
				Internal assessment	semester	
I	II	BOTT2IA	Basics of Vascular plants and Phytogeography	25	75	4
			Practical-I	10	40	2
	II	BOT-PNT	Plant nursery management	40	10	2
II	IV	BOT-401	Plant Physiology and Metabolism	30	70	3
			Practical- 401	25	25	2
II	IV	BOT-402	Cell Biology, Genetics and Plant Breeding.	30	70	3
			Practical- – 402	25	25	2
III	VI	BOT-601	Plant Tissue Culture and its Biotechnological Applications(G.E)	30	70	3
			Practical-v- 601	15	35	2
III	VI	BOT-602	Plant Diversity and Human welfare (C.E)	30	70	3
			Practical-v- 602	20	30	2
	VI	BOT-603	Ethnobotany and Medicinal Botany(C.E)	30	70	3
			Practical-v- 603	20	30	2
	VI	BOT-604	Pharmacognosy and Phytochemistry(C.E)	30	70	3
			Practical-v- 604	20	30	2

A.G. & S.G. SIDDHARTHA DEGREE COLLEGE OF ARTS & SCIENCE

Vuyyuru- 521165.

NAAC reaccredited at 'A' level

Autonomous -ISO 9001 – 2015 Certified

Title of the Paper: Basics of Vascular plants and Phytogeography

(Pteridophytes, Gymnosperms, Taxonomy of Angiosperms and Phytogeography)

Semester : II

Course Code	BOTT21A	Course Delivery Method	Class Room / Blended Mode - Both
Credits	3	CIA Marks	25
No. of Lecture Hours / Week	4	Semester End Exam Marks	75
Total Number of Lecture Hours	60	Total Marks	100
Year of Introduction :2017-18	Year of Offering: 2021 - 22	Year of Revision: -	Percentage of Revision: -

Course Prerequisites: Knowledge of Pteridophytes, Gymnosperms, Taxonomy of Angiosperms and Phytogeography studied in intermediate.

Course Description:

This course will provide one with a basic and comprehensive understanding of anatomical structure and functions. Enable the student with depth of topics and helps them to gain an appreciation in the embryology of Angiosperms. On the other hand, importance of understanding plant ecology and biodiversity provides an extensive knowledge to the student.

Course Objectives:

1. The study of Pteridophytes
2. The study of Gymnosperms
3. Knowledge of Basic aspects of Taxonomy
4. Study of Systematic Taxonomy
5. Knowledge of Phytogeography

Course Outcomes: At the end of this course, students should be able to:

CO1: Gain knowledge in the classification and comparison of Pteridophytes and Gymnosperms based on their morphology, anatomy, reproduction and life cycle.

CO2: Justify evolutionary trends in Tracheophytes to adapt for land habitat. Evaluate the ecological, ethnic and economic value of different tracheophytes and summarize their good and services for human welfare

CO3: Explanation of the process of fossilization and compare the characteristics of extinct and extant plants.

CO4: Analyze the morphology of the most common Angiosperm plants of their localities and recognize their families.

CO5: Locate different Phytogeographical regions of the world and India and analyze their floristic wealth.

Syllabus

Course Details

Unit	Learning Units	Lecture Hours
I	<p>Pteridophytes General characteristics of Pteridophyta; classification of Smith (1955) upto divisions. Occurrence, morphology, anatomy, reproduction (developmental details are not needed) and life history of (a) <i>Lycopodium</i> (Lycopsida) and (b) <i>Marsilea</i> (Filicopsida). Stelar evolution in Pteridophytes Heterospory and seed habit.</p>	12
II	<p>Gymnosperms General characteristics of Gymnosperms; Sporne classification upto classes. Occurrence, morphology, anatomy, reproduction (developmental details are not needed) and life history of (a) <i>Cycas</i> (Cycadopsida) and (b) <i>Gnetum</i> (Gnetopsida). Outlines of geological time scale. A brief account on Cycadeoidea</p>	12
III	<p>Basic aspects of Taxonomy Aim and scope of taxonomy; Species concept: Taxonomic hierarchy, species, genus and family. Plant nomenclature: Binomial system, ICBN –rules for nomenclature. Herbarium and its techniques, BSI herbarium and Kew herbarium; concept of digital herbaria. Bentham and Hooker system of classification Systematic description and economic importance of the following families:(a) Annonaceae (b) Curcubitaceae</p>	
IV	<p>Systematic Taxonomy Systematic description and economic importance of the following families: (a) Asteraceae (b) Asclepiadaceae (c) Amaranthaceae (d) Euphorbiaceae (e) Orchidaceae (f) Arecaceae (i) Poaceae Outlines of Angiosperm Phylogeny Group (APG IV).</p>	12
V	<p>Phytogeography Principles of Phytogeography, Distribution (wides, endemic, discontinuous species) Endemism – types and causes. Phytogeographic regions of World. Pytogeographic regions of India. Vegetation types in Andhra Pradesh</p>	12

Textbook:

1. Botany – I (Vrukshasastram-I): Telugu Akademi, Hyderabad
2. Botany – II (Vrukshasastram-II): Telugu Akademi, Hyderabad
3. Acharya, B.C., (2019) Archchegoniates, Kalyani Publishers, New Delhi.
4. Bhattacharya, K., G. Hait & Ghosh, A. K., (2011) A Text Book of Botany, Volume II, New Central Book Agency Pvt. Ltd., Kolkata
5. Hait, G., K. Bhattacharya & A.K. Ghosh (2011) A Text Book of Botany, Volume-I, New Central Book Agency Pvt. Ltd., Kolkata
6. Pandey, B.P. (2013) College Botany, Volume-I, S. Chand Publishing, New Delhi Pandey, B.P. (2013) College Botany, Volume-II, S. Chand Publishing, New Delhi

Recommended Reference book:

1. Smith, G.M. (1971) Cryptogamic Botany Vol. II., Tata McGraw Hill, New Delhi
 2. Shama, O.P. (2012) Pteridophyta. Tata McGraw-Hill, New Delhi
 3. Kramer, K.U. & P. S. Green (1990) The Families and Genera of Vascular Plants, Volume –I: Pteridophytes and Gymnosperms (Ed. K. Kubitzki) .Springer-Verlag, New York
 6. Bhatnagar, S.P. & Alok Moitra (1996) Gymnosperms. New Age International, New Delhi Govil, C.M. (2007) Gymnosperms : Extinct and Extant. KRISHNA Prakashan Media (P) Ltd. Meerut & Delhi
 7. Sporne, K.R. (1971) The Morphology of Gymnosperms. Hutchinsons Co. Ltd., London
 8. Arnold, C.A., (1947) An introduction to Paleobotany McGraw –Hill Book Company, INC, New York
 9. Stewart, W.N., and G.W. Rothwell (2005) Paleobotany and the evolution of plants Cambridge University Press, New York Cambridge. London.
 10. Sambamurty, A.V.S.S. (2005) Taxonomy of Angiosperms I. K. International Pvt. Ltd., New Delhi
 11. Singh, G. (2012). Plant Systematics: Theory and Practice. Oxford & IBH Pvt. Ltd., New Delhi.
 12. Simpson, M.G. (2006). Plant Systematics. Elsevier Academic Press, San Diego, CA, U.S.A.
 - Cain, S.A. (1944) Foundations of Plant Geography Harper & Brothers, N.Y.
 13. Mani, M.S (1974) Ecology & Biogeography of India Dr. W. Junk Publishers, The Hague
- Course Delivery method:** Face-to-face / Blended

Course has focus on: Foundation

Websites of Interest:

- <https://www.youtube.com/watch?v=VA2LNWkZnW0>
<https://www.youtube.com/watch?v=zDUCacewuAg>
<https://www.youtube.com/watch?v=sfFDOSM-EuA>
<https://www.youtube.com/watch?v=wKNox2weqW4>

Co-curricular Activities:

A. Measurable:

1. Collection and identification of Pteridophytes from their native locality/ making an album by collecting photographs of Pteridophytes.
2. Collection and identification of Gymnosperms from their native locality/making an album by collecting photographs of Gymnosperms.
3. Collection of information on famous herbaria in the world and preparation of a report.
4. Collection of information on famous botanic gardens in the world and preparation of a report.
5. Collection of data on plants of ethnic and ethnobotanical importance from their native locality.
6. Preparation of a local flora by enlisting the plants of their native place.

c. Assignments: Written assignment at home / during 'O' hour at college;

Lycopodium-life cycle, Marselia-life cycle, Cycas-life cycle, Gnetum-life cycle, Bentham & Hooker classification, Stellar evolution in Pteridophytes, characteristics of Cycadeoidea, Asteraceae-taxonomy, Asclepiadaceae-taxonomy, Euphorbiaceae-taxonomy, Cucurbitaceae-taxonomy, Principles of phytogeography, Endemism types & causes, Phytogeographic regions of India.

preparation of charts with drawings, making models etc., on topics included in syllabus. Five kingdom classification, Miller & Urey experiment, Shape and Symmetry of viruses.

B. General:

1. Quiz

Model Question Paper Structure for SEE

Max.: 75 Marks

Min.Pass : 30 Marks

Section-A

Answer Any Five atleast one from each unit

5 x 5M = 25Marks

1. What is meant by heterospory? Justify the advantage of heterospory over homosporous.
CO1, L1.
2. Write about Protocorm and its morphological nature.**CO1, L6.**
3. Explain the characteristics of Cycadeoidea. **CO2, L2.**
4. Enumerate Geological time scale. **CO2, L1.**
5. Describe ICBN rules for nomenclature. **CO3, L2.**
6. Write a note on Angiosperms Phylogeny Group. **CO4, L6.**
7. Discuss about the Vegetation types in AndhraPradesh.**CO5, L2.**
8. Explain the causes and types of Endemism. **CO5, L2.**

Section-B

Answer the following questions (5 x 10M = 50Marks)

9. (a) Describe diverse gametophytes present in the *Lycopodium* species. **CO1, L2.**
(Or) **Unit I**
(b) What is sporocarp? Describe the structure of *Marselia* Sporocarp. **CO1, L2.**
10. (a) Describe the anatomy of *Cycas* leaflet. Add a note on xerophytic features of it. **CO2, L2.**
(Or) **Unit II**
(b) Describe the structure of *Gnetum* male and female cones. **CO2, L2.**
11. (a) What is Natural System of Classification, Bentham and Hooker System of Classification? **CO3, L1.**
(Or) **Unit III**
(b) Describe vegetative and floral characters of Cucurbitaceae. Add a note on andeconomic Importance **CO3, L1.**
12. (a) Elucidate floral characters of Asteraceae. **CO4, L1.**
(Or) **Unit IV**
(b) Describe floral characters of Poaceae. Add a note on economic importance **CO4, L1.**
13. (a) What is Phytogeography? Explain principles of Phytogeography. **CO5, L2.**
(Or) **Unit V**
(b) Explain about Phytogeographic region of India.**CO5, L1.**

A.G. & S.G. SIDDHARTHA DEGREE COLLEGE OF ARTS & SCIENCE

Vuyyuru - 521165.

NAAC recredited at 'A' level

Autonomous -ISO 9001 – 2015 Certified

Title of the Paper: **Basics of Vascular plants and Phytogeography**

(Pteridophytes, Gymnosperms, Taxonomy of Angiosperms and Phytogeography)

Total Number of Lecture Hours: 30

SEMESTER - II	BOTT21A	2021-22	B.Sc, B.Z.C,A.B.C
----------------------	----------------	----------------	--------------------------

Course Prerequisites: Knowledge of Pteridophytes, Gymnosperms, Taxonomy of Angiosperms and Phytogeography studied in intermediate.

Course Description:

This course will provide one with a basic and comprehensive understanding of anatomical structure and functions. Enable the student with depth of topics and helps them to gain an appreciation in the embryology of Angiosperms. On the other hand, importance of understanding plant ecology and biodiversity provides an extensive knowledge to the student.

Course Objectives

1. The study of Pteridophytes
2. The study of Gymnosperms
3. Knowledge of Basic aspects of Taxonomy
4. Study of Systematic Taxonomy
5. Knowledge of Phytogeography

Course Outcomes: At the end of this course, students should be able to:

CO1: Demonstrate the techniques of section cutting, preparing slides, identifying of the material and drawing exact figures.

CO2: Compare and contrast the morphological, anatomical and reproductive features of vascular plants.

CO3: Identify the local angiosperms of the families prescribed to their genus and species level and prepare herbarium.

CO4: Exhibit skills of preparing slides, identifying the given twigs in the lab and drawing figures of plant twigs, flowers and floral diagrams as they are.

CO5: Prepare and preserve specimens of local wild plants using herbarium techniques.

Syllabus

1. Study/ microscopic observation of vegetative, sectional/anatomical and Reproductive structures of the following using temporary or permanent slides/ specimens/ mounts:
 - a. Pteridophyta: *Lycopodium* and *Marselia*
 - b. Gymnosperms: *Cycas* and *Gnetum*
2. Study of fossil specimens of Cycadeoidea and Pentoxylon (photographs /diagramscan be shown if specimens are not available).
3. Demonstration of herbarium techniques.
4. Systematic / taxonomic study of locally available plants belonging to the families prescribed in theory syllabus. (Submission of 30 number of Herbarium sheets of wildplants with the standard system is mandatory).
5. Mapping of phytogeographical regions of the globe and India.

Textbook:

1. A text book of Practical Botany-I Ashok Bendra and Ashok kumar
2. Practical manual of College Botany I and II- B.S..Reddy and S.M.Reddy

Course Delivery method: Face-to-face / Blended.**Course has focus on:**

Skill Development **Websites of**

Interest:

<https://youtu.be/RJsOOhws5gI>

<https://youtu.be/9xtB1G4kJSQ>

<https://youtu.be/2wFN9YmkBOQ>

Model Question Paper Structure for SEE

Time: 3hrs.

Max. Marks 40M

1. Take T.S. of the material 'A' (Pteridophyta), make a temporary slide and justify the identification with apt points.....**8M**
2. Take T.S. of the material 'B' (Gymnosperms), make a temporary slide and justify the identification with apt points.....**8M**
3. Describe the vegetative and floral characters of the material 'C' (Taxonomy of Angiosperms) and derive its systematic position.....**8M**
4. Identify the specimen 'D' (Fossil Gymnosperm) and give specific reasons.....**3M**

1. Locate the specified phytogeographical regions the world / India (E) map supplied to you

2X2=4 M

2. Record + Herbarium & amp; Field note book **5+4 = 9M**

A.G.& S.G. SIDDHARTHA DEGREE COLLEGE OF ARTS & SCIENCE

Vuyyuru - 521165.

NAAC reaccruited at 'A' level

Autonomous -ISO 9001 – 2015 Certified

Title of the Paper: **Plant Physiology and Metabolism**

Semester: IV

Course Code	BOT - 401	Course Delivery Method	Class Room / Blended Mode - Both
Credits	3	CIA Marks	30
No. of Lecture Hours / Week	4	Semester End Exam Marks	70
Total Number of Lecture Hours	60	Total Marks	100
Year of Introduction :2021-22	Year of Offering: 2021 - 22	Year of Revision: --	Percentage of Revision: -

Learning Objectives:

- On successful completion of this course, the students will be able to;
- Comprehend the importance of water in plant life and mechanisms for transport of water and solutes in plants.
- Evaluate the role of minerals in plant nutrition and their deficiency symptoms.
- Interpret the role of enzymes in plant metabolism.
- Critically understand the light reactions and carbon assimilation processes responsible for synthesis of food in plants.
- Analyze the biochemical reactions in relation to Nitrogen and lipid metabolisms.
- Evaluate the physiological factors that regulate growth and development in plants.
- Examine the role of light on flowering and explain physiology of plants under stress conditions

THEORY: Learning outcomes:

- On _____
successful completion of this course, the students will be able to;
Understand on the organization of tissues and tissue systems in plants.
- Illustrate and interpret various aspects of embryology.
- Discuss the basic concepts of plant ecology, and evaluate the effects of environmental and biotic factors on plant communities.
- Appraise various qualitative and quantitative parameters to study the population and community ecology.
- Correlate the importance of biodiversity and consequences due to its loss.
- Enlist the endemic/ endangered flora and fauna from two biodiversity hot spots in India and assess strategies for their conservation.

SYLLABUS

Unit – 1	<p>Plant - water relations 10HRS</p> <p>Importance of water to plant life, physical properties of water, diffusion, Imbibition, Osmosis. Water potential, osmotic potential, pressure potential.</p> <p>Absorption and lateral transport of water; Ascent of sap</p> <p>Transpiration: stomata structure and mechanism of stomatal movements (K^+ ion flux).</p> <p>Mechanism of phloem transport; source-sink relationships.</p>
Unit – 2	<p>Mineral nutrition, Enzymes and Respiration 14 HRS</p> <p>Essential macro and micro mineral nutrients and their role in plants; symptoms of mineral deficiency.</p> <p>Absorption of mineral ions; passive and active processes.</p> <p>Characteristics, nomenclature and classification of Enzymes. Mechanism of enzyme action, enzyme kinetics.</p> <p>Respiration: Aerobic and Anaerobic; Glycolysis, Krebs cycle; electron transport system, mechanism of oxidative phosphorylation, Pentose Phosphate Pathway (HMP shunt).</p>
Unit – 3	<p>Photosynthesis and Photorespiration 12 HRS</p> <p>Photosynthesis: Photosynthetic pigments, absorption and action spectra; Red drop and Emerson enhancement effect</p> <p>Concept of two photosystems; mechanism of photosynthetic electron transport and evolution of oxygen; photophosphorylation</p> <p>Carbon assimilation pathways (C_3, C_4 and CAM); Photorespiration - C_2 pathway</p>
Unit – 4	<p>Nitrogen and lipid metabolism 12 HRS</p> <p>Nitrogen metabolism: Biological nitrogen fixation – asymbiotic and symbiotic nitrogen fixing organisms. Nitrogenase enzyme system.</p> <p>Lipid metabolism: Classification of Plant lipids, saturated and unsaturated fatty acids.</p> <p>Anabolism of triglycerides, β-oxidation of fatty acids, Glyoxylate cycle.</p>
Unit – 5	<p>Plant growth – development and stress physiology 12 HRS</p> <p>Growth and Development: Definition, phases and kinetics of growth.</p> <p>Physiological effects of Plant Growth Regulators (PGRs) - auxins, gibberellins, cytokinins, ABA, ethylene and brassinosteroids.</p> <p>Physiology of flowering: Photoperiodism, role of phytochrome in flowering.</p> <p>Seed germination and senescence; physiological changes.</p>

Text books:

- Botany – IV (Vrukshasastram-II) : Telugu Akademi, Hyderabad
- Pandey, B.P. (2013) *College Botany, Volume-III*, S. Chand Publishing, New Delhi
- Ghosh, A. K., K. Bhattacharya & G. Hait (2011) *A Text Book of Botany, Volume- III*, New Central Book Agency Pvt. Ltd., Kolkata

Books for Reference:

- Aravind Kumar & S.S. Purohit (1998) *Plant Physiology – Fundamentals and Applications*, AgroBotanica, Bikaner
- Datta, S.C. (2007) *Plant Physiology*, New Age International (P) Ltd., Publishers, New Delhi
- Hans Mohr & P. Schopfer (2006) *Plant Physiology*, Springer (India) Pvt. Ltd., New Delhi
- Hans-Walter heldt (2005) *Plant Biochemistry*, Academic Press, U.S.A.
- Hopkins, W.G. & N.P.A. Huner (2014) *Introduction to Plant Physiology*, Wiley India Pvt. Ltd., New Delhi
- Noggle Ray & J. Fritz (2013) *Introductory Plant Physiology*, Prentice Hall (India), New Delhi
- Pandey, S.M. & B.K. Sinha (2006) *Plant Physiology*, Vikas Publishing House, New Delhi
- Salisbury, Frank B. & Cleon W. Ross (2007) *Plant Physiology*, Thomsen & Wadsworth, Australia & U.S.A
- Sinha, R.K. (2014) *Modern Plant Physiology*, Narosa Publishing House, New Delhi
- Taiz, L. & E. Zeiger (2003) *Plant Physiology*, Panima Publishers, New Delhi
- Verma, V. (2007) *Text Book of Plant Physiology*, Ane Books India, New Delhi

BOTANY	BOT- 401C	w.e.f. 2021-22	B. Sc. (BZC), AQUA
---------------	------------------	-----------------------	---------------------------

II B. Sc – BOTANY

Model Question Paper

SEMESTER- IV

PAPER-IV: Time: 3 Hours

Max. Marks: 70

.....
SECTION-A

Answer any four of the following questions.

4x 5 = 20Marks

(Draw diagrams wherever necessary)

1. Types of Transpiration
2. Water potential.
3. Nitrogen.
4. Anaerobic respiration.
5. Emerson enhancement effect
6. Ethylene.
7. Photo periodism.
8. β -oxidation of fatty acids.

SECTION-B

Answer any five of the following questions.

5x10 = 50Marks

(Draw diagrams wherever necessary)

9. Write an essay on Ascent of sap.
10. Write an essay on the Translocation of organic substances in higher plants
11. Write an essay on the absorption of mineral ions.
12. Give an account on Krebs cycle?
13. Describe the carbon assimilation pathway in C4 plants.
14. Explain the non cyclic electron transport and evolution of oxygen?
15. Write an essay on various types of Lipids.
16. describe about physiological effects in Auxins and Gibberellins.

Guide lines for paper setter: (for Paper III – BOT- 401) w.e.f 2021-22

1. In **section A**: Unit III, IV must carry **one** question, Unit I,II & V must carry **two** questions.
2. In **section- B**: Set minimum **two** questions from Unit I, II, III . **One** question each from Unit IV and Unit V.
3. See the following table and Model paper for marks distribution.
4. Please provide the scheme of valuation for the paper.
5. Question paper should be both in English and Telugu media.

Unit	Section - A		Section - B		Weightage in
	Questions	Marks	Questions	Marks	Marks
Unit – I	2		2		
	10		20		30
Unit - II	2		2		
	10		20		30
Unit – III	1		2		
	05		20		25
Unit – IV	1		1		
	05		10		15
Unit – V	2		1		
	10		10		20
Max. Q & marks	8	(x 5) = 40	8	(x 10) = 80	(Total questions =16) Total marks = 120
Max. Q and marks for Valuation	Questions	Marks	Questions	Marks	Max. marks
	4	(4 X 5M) = 20 M	5	(5 X 10M)= 50 M	70M

INTERNAL EXAMS - 30Marks

(20 marks for unit tests, 5marks for Attendance 5 marks for seminars)

Practical Syllabus of Botany Core Course – 4 / Semester – IV Plant Physiology and Metabolism

Course outcomes: On successful completion of this practical course, students shall be able to:

1. Conduct lab and field experiments pertaining to Plant Physiology, that is, biophysical and biochemical processes using related glassware, equipment, chemicals and plant material.
2. Estimate the quantities and qualitative expressions using experimental results and calculations
3. Demonstrate the factors responsible for growth and development in plants.

Practical Syllabus

1. Determination of osmotic potential of plant cell sap by plasmolytic method using *Rhoeo/ Tradescantia* leaves.
2. Calculation of stomatal index and stomatal frequency of a mesophyte and a xerophyte.
3. Determination of rate of transpiration using Cobalt chloride method / Ganong's potometer (at least for a dicot and a monocot).
4. Effect of Temperature on membrane permeability by colorimetric method.
5. Study of mineral deficiency symptoms using plant material/photographs.
6. Demonstration of amylase enzyme activity and study the effect of substrate and Enzyme Concentration.
7. Separation of chloroplast pigments using paper chromatography technique.
8. Demonstration of Polyphenol oxidase enzyme activity (Potato tuber or Apple fruit)
9. Anatomy of C₃, C₄ and CAM leaves
10. Estimation of protein by biuret method/Lowry method
11. Minor experiments – Osmosis, Arc- auxonometer, ascent of sap through xylem, cytoplasmic streaming.

Model Question Paper for Practical Examination

Semester – IV/ Botany Core Course – 4

Plant Physiology and Metabolism

1. Conduct the experiment 'A' (Major experiment), write aim, principle, material and Apparatus/equipment, procedure, tabulates results and make conclusion..... 10 M
2. Demonstrate the experiment 'B' (Minor experiment), write the principle, procedure and give inference.....6 M
 1. Identify the following with apt reasons. 3 x 2 = 6 M
 - A. Plant water relations / Mineral nutrition
 - B. Plant metabolism
 - C. Plant growth and development
 2. Viva-voce = 3 M

Internals:

1. Record10M
2. Assignments05 M
3. Project work.....05 M
4. Internal practical exam.....05 M

A. Measurable :

Student seminars:

1. Anti transpirants and their significance in crop physiology and horticulture.
2. Natural chelating agents in plants.
3. Criteria of essentiality of elements and beneficial elements.
4. Hydroponics, aquaponics and aeroponics.
5. Mycorrhizal association and mineral nutrition in plants.
6. Non- proteinaceous enzymes.
7. Respiratory inhibitors.
8. Structure of ATPase and Chemiosmotic hypothesis.
9. Transpiration and photosynthesis – a compromise.
10. Amphibolic pathways and bypass pathways in plants.
11. Non-biological nitrogen fixation.
12. Role of Hydrogenase in nitrogen fixation.
13. Plant lectins – their role in plants and use in medicine and medical research.

A.G. & S.G. SIDDHARTHA DEGREE COLLEGE OF ARTS & SCIENCE

Vuyyuru - 521165.

NAAC reaccredited at 'A' level

Title of the Paper: **Cell Biology, Genetics and Plant Breeding****Semester: IV**

Course Code	BOT - 402	Course Delivery Method	Class Room / Blended Mode - Both
Credits	3	CIA Marks	30
No. of Lecture Hours / Week	4	Semester End Exam Marks	70
Total Number of Lecture Hours	60	Total Marks	100
Year of Introduction :2021-22	Year of Offering: 2021 - 22	Year of Revision: --	Percentage of Revision: --

Theory: Learning out comes:

- On successful completion of this course, the students will be able to:
- Distinguish prokaryotic and eukaryotic cells and design the model of a cell.
- Explain the organization of a eukaryotic chromosome and the structure of genetic material.
- Demonstrate techniques to observe the cell and its components under a microscope.
- Discuss the basics of Mendelian genetics, its variations and interpret inheritance of traits in living beings.
- Elucidate the role of extra-chromosomal genetic material for inheritance of characters.
- Evaluate the structure, function and regulation of genetic material.
- Understand the application of principles and modern techniques in plant breeding.
- Explain the procedures of selection and hybridization for improvement of crops.

SYLLABUS

Unit – 1	The Cell: Cell theory; prokaryotic vs eukaryotic cell; animal vs plant cell; a brief account on ultra-structure of a plant cell.	12 Hrs.
-----------------	--	----------------

	<p>Ultra-structure of cell wall. Ultra-structure of plasma membrane and various theories on its organization. Polymorphic cell organelles (Plastids); ultra structure of chloroplast. Plastid DNA.</p>
Unit – 2	<p>Chromosomes: 11Hrs. Prokaryotic vs eukaryotic chromosome. Morphology of a eukaryotic chromosome. Euchromatin and Heterochromatin; Karyotype and ideogram. Brief account of chromosomal aberrations - structural and numerical changes Organization of DNA in a chromosome (nucleosome models).</p>
Unit – 3	<p>Mendelian and Non-Mendelian genetics 14Hrs. Mendel's laws of inheritance. Incomplete dominance and co-dominance; Multiple allelism. Complementary, supplementary and duplicate gene interactions (plant based examples are to be dealt). A brief account of linkage and crossing over; Chromosomal mapping - 2 point and 3 point test cross.</p>
Unit – 4	<p>Structure and functions of DNA 12 Hrs. Watson and Crick model of DNA. Brief account on DNA Replication (Semi- conservative method). Brief account on Transcription, types and functions of RNA. Gene concept and genetic code and Translation. Regulation of gene expression in prokaryotes - Lac Operon.</p>
Unit – 5	<p>Plant Breeding 12 Hrs. Plant Breeding and its scope; Genetic basis for plant breeding. Plant Introduction and acclimatization. Definition, procedure; applications and uses; advantages and limitations of : (a) Mass selection, (b) Pure line selection and (c) Clonal selection. Hybridization – schemes, and technique; Heterosis (hybrid vigor). A brief account on Molecular breeding – DNA markers in plant breeding. RAPD, RFLP.</p>

**B.Sc – BOTANY
SEMESTER -V. THEORY MODEL PAPER**

Time: 3 Hours

Max. Marks: 70

SECTION-A

Answer any FOUR of the following question
(Draw diagrams wherever necessary)

4x5=20M.

1. Cell Theory
2. karyotype.
3. Rho - factor
4. Back cross and test cross.
5. supplementary genes
6. t RNA
- 7 RFLP
8. Hybridization.

SECTION-B

Answer any FIVE of the following questions.

5x10= 50M.

(Draw diagrams wherever necessary)

9. Describe the Ultra structure and functions of cell membrane.
10. Describe the Ultra structure of cell wall.
11. Give brief account on of chromosomal aberrations.
12. Explain the Mendel's law of inheritance.
13. Define linkage. Describe the different types of Linkage.
14. Write about structure and replication of DNA.
15. Write an essay on mechanism and Regulation of gene Expression in Prokaryotes
16. Discuss about methods of Crop improvement.

Guide lines for paper setter: (for Paper V-BOT-402) W.e.f. 2021-22

1. In Section A: Unit I & II, must carry one question from each unit. Unit III ,IV & V

Must carry 2 questions.

2. In section-B: Set minimum Two questions from Unit I, III & IV One question from Unit II&V.

3. See the following table and Model paper.

4. Please provide the scheme of valuation for the paper.

5. Question paper should be both in English and Telugu media.

Unit	Section - A		Section - B		Weightage in
	Questions	Marks	Questions	Marks	Marks
Unit – I	1		2		
		5	20		25
Unit – II	1		1		
		05	10		15
Unit –III	2		2		
		10		20	30
Unit-IV	2		2		
		10		20	30
Unit-V	2		1		
		10		10	20
Max .Q & marks	8	(x 5) =40	8	(x 10) = 80	(Total questions =16) Marks 120
Max. Q and marks for Valuation	Questions	Marks	Questions	Marks	Max. marks
	4		5		
		(4 x 5) = 20		(5 x 10) = 50	70

INTERNAL EXAMS - 30Marks

(20 marks for unit tests, 5marks for Attendance 5 marks for seminars)

Practical Syllabus of Botany Core Course –5/IVSemester

Cell Biology, Genetics and Plant Breeding

(Total hours of laboratory exercises 30 Hrs. @ 02 Hrs. /Week)

Course Outcomes:

- After successful completion of this practical course the student shall be able to:

- Show the understanding of techniques of demonstrating Mitosis and Meiosis in the laboratory and identify different stages of cell division.
- Identify and explain with diagram the cellular parts of a cell from a model or picture and prepare models
- Solve the problems related to crosses and gene interactions.
- Demonstrate plant breeding techniques such as emasculation and bagging

Practical Syllabus:

1. Study of ultra structure of plant cell and its organelles using Electron microscopic Photographs/models.
2. Demonstration of Mitosis in *Allium cepa*/*Aloe vera* roots using squash technique; observation of various stages of mitosis in permanent slides.
3. Demonstration of Meiosis in P.M.C.s of *Allium cepa* flower buds using squash technique; observation of various stages of meiosis in permanent slides.
4. Study of structure of DNA and RNA molecules using models.
5. Solving problems monohybrid, dihybrid, back and test crosses.
6. Solving problems on gene interactions (atleast one problem for each of the gene interactions in the syllabus).
7. Chromosome mapping using 3- point test cross data.
8. Demonstration of emasculation, bagging, artificial pollination techniques for hybridization.

Model paper for Practical Examination

Semester-IV / Botany Core Course – 5

Cell Biology, Genetics and Plant Breeding

Max. Time: 3 Hrs.

Max. Marks: 50

1. Make a cytological preparation of given material 'A' (mitosis or meiosis in Onion) by squash technique, report any two stages, draw labeled diagrams and write the reasons. 10 M
2. Solve the given Genetic problem (Dihybrid cross/ Interaction of genes/ 3-point test cross) 'B' and write the conclusions. 7 M
3. Identify the following and justify with apt reasons. 3 x 2 = 06M
- B.** Cell Biology (Cell organelle)
 - C.** Genetics (DNA/RNA)
 - D.** Plant Breeding
4. Viva-voce = 2 M

Internals:

1. Record10M
2. Assignments.....05 M
3. Project work.....05 M
4. Internal practical exam.....05 M

Suggested co-curricular activities for Botany Core Course- 5 in Semester-IV:

A. Measurable :

a. Student seminars :

1. Light microscopy : bright field and dark field microscopy.
2. Scanning Electron Microscopy (SEM).

3. Transmission Electron Microscopy (TEM).
4. Mitosis and Meiosis
5. Cell cycle and its regulation.
6. Cell organelles bounded by single membrane.
7. Prokaryotic chromosomes
8. Special types of chromosomes : Polytene, Lampbrush and B-chromosomes.
9. Different forms of DNA.
10. Gene mutations.
11. DNA damage and repair mechanisms.
12. Reverse transcription.
13. Protein structure.
14. Modes of reproduction in plants.
15. Modes of pollination in plants

b. Student Study Projects :

1. Study of mitotic cell cycle in roots of *Allium cepa*
2. Study of mitotic cell cycle in roots of *Aloe vera*
3. Observation of chromosomal aberrations in *Allium cepa* root cells exposed to industrial effluent(s).
4. Observation of chromosomal aberrations in *Allium cepa* root cells exposed to heavy metal(s).
5. Observation of polyembryony in *Citrus* spp. and *Mangifera indica*.

c. Assignments: Written assignment at home / during 'O' hour at college; preparation of charts with drawings, making models etc., on topics included in syllabus.

B. General :

1. Field visit to Agriculture/Horticulture University/ Research station to observe Plant breeding methods.
2. Group Discussion (GD)/ Quiz/ Just A Minute (JAM) on different modules in syllabus of the course.

RECOMMENDED ASSESSMENT OF STUDENTS:

Recommended continuous assessment methods for all courses:

Some of the following suggested assessment methodologies could be adopted. Formal assessment for awarding marks for Internal Assessment in theory.

(a) Formal:

1. The oral and written examinations (Scheduled and surprise tests),
2. Simple, medium and Critical Assignments and Problem-solving exercises,
3. Practical assignments and laboratory reports,
4. Assessment of practical skills,
5. Individual and group project reports,
6. Seminar presentations,
7. Viva voce interviews.

(b) Informal:

1. Computerized adaptive testing, literature surveys and evaluations,
2. Peers and self-assessment, outputs form individual and collaborative work
3. Closed-book and open-book tests,

A.G.& S.G. SIDDHARTHA DEGREE COLLEGE OF ARTS & SCIENCE

Vuyyuru - 521165.

NAAC reaccredited at 'A' level

Autonomous -ISO 9001 – 2015 Certified

Course Code	BOT - 601	Course Delivery Method	Class Room / Blended Mode - Both
-------------	------------------	------------------------	-------------------------------------

Hours			
Year of Introduction :2017-18	Year of Offering: 2019- 20	Year of Revision: -	Percentage of Revision: --

Title of the Paper: **Plant tissue culture and its Biotechnological applications**

Semester: **VI**

Course Description:

This course will provide one with a basic and comprehensive understanding of plant tissue culture. Enable the student with depth of topics and helps them to gain an appreciation in the tissue culture techniques. On the other hand, importance of understanding biotechnological applications provides an extensive knowledge to the student.

Course Objectives

1. To study methods of sterilization
2. To study medium preparation
3. To study tissue culturing techniques (endosperm, embryo)
4. To study research techniques, including methods of molecular biology, Genetic engineering.

Course Outcomes: At the end of this course, students should be able to: CO 1 : Analyze the basic principles of plant tissue culture CO2: Explain the, various culturing techniques.

CO3: Demonstrate recombinant DNA technology.

CO4: Discuss the methods of gene transfer.

CO5: Understand the applications of plant genetic engineering.

CO6: Elucidate the selection of transgenics.

SYLLABUS

Unit – 1	<p>PLANT TISSUE CULTURE – 1 (12hrs) History of plant tissue culture research - basic principles of plant tissue callus culture, Meristem culture, organ culture, Totipotency of cells. Sterilization procedures, culture media composition and preparations of explants. Murashige and Skoog's (MS medium), Cell and protoplast culture. Somatic Hybrids and Cybrids (out lines), Artificial Seeds, Somaclonal variations. Applications of Tissue culture (Brief account).</p>
Unit – 2	<p>Plant Tissue culture -2 (12hrs) Endosperm culture – Embryo culture -culture requirements – applications, embryo rescue technique. Cryopreservation; Germ plasm conservation.</p>

Unit – 3	R Recombinant DNA technology (12hrs) 1. r-DNA technology: Steps in r-DNA technology and tools 2. Cloning Vectors: Prokaryotic (pBR322, Ti plasmid and Lambda phage, Eukaryotic Vectors (YAC and briefly PAC) 3. Gene cloning (Bacterial Transformation and selection of recombinant clones, PCR Mediated gene cloning)
Unit – 4	Methods of gene transfer (12hrs) Methods of gene transfer- Agrobacterium-mediated, direct gene transfer By Electroporation, Microinjection, Micro projectile bombardment. 2. Selection of transgenics – selectable marker and reporter genes (Luciferase, GUS, GFP).
Unit – 5	Applications of Biotechnology (12 hrs) Applications of Plant Genetic Engineering – crop improvement, herbicide resistance, insect resistance, virus resistance. Genetic modification – transgenic plants for pest resistant (Bt-cotton); herbicide resistance (Round Up Ready soybean); improved agronomic traits flavrSavr tomato, Golden rice.

III B. Sc – BOTANY Model paper (2021-2022)

Plant tissue culture and its Biotechnological applications

SEMESTER- VI

ELECTIVE-C

PAPER – VII

Time: 3 Hours

Paper code: BOT-VII C

Max. Marks: 70

SECTION-A

Answer any FOUR of the following question
(Draw diagrams wherever necessary)

4x5=20M.

1. Organ culture.
2. Somatic hybrids.
3. Cryopreservation.

4. Application of tissue culture.
5. Restriction Endonuclease.
6. Bacterial transformation.
7. GUS.
8. Bt-Cotton.

SECTION-B

Answer any Five of the following questions.

5 x 10= 50M.

(Draw diagrams wherever necessary)

9. Describe the composition and preparation of different culture media.
10. Explain the callus sub-culture and their growth and measurement.
11. Give an account on secondary metabolites.
12. Write notes on endosperm culture and their applications.
13. Explain the PCR mediated gene cloning.
14. Explain the various types of cloning vectors.
15. Write about methods of gene transfer techniques.
16. Write an essay on application of Biotechnology in the field of medicine and industry.

Guide lines for paper setter: (for Paper VII -BOT-601) W.e.f. 2021-22.

1. In Section A: Unit I,III, IV must carry Two question from each unit. Unit II, V must carry one question.
2. In section-B: Set minimum two questions from Unit I, II, III and Set One Question from IV, V.
3. See the following table and Model paper.
4. Please provide the scheme of valuation for the paper.
5. Question paper should be both in English and Telugu media.

Unit	Section – A		Section - B		Weightage in Marks
	Questions	Marks	Questions	Marks	

Unit – I	2	2		
	10	20	30	
Unit – II	1	2		
	5	20	25	
Unit – III	2	2		
	10	20	30	
Unit-IV	2	1		
	10	10	20	
Unit-V	1	1		
	5	10	15	
Max. Q & marks	8 (x 5) = 40	8 (x 10) = 80	(Total questions = 16) Marks 120	
Max. Q and marks for Valuation	Questions	Marks	Questions	Marks
	5		5	
	(4 x 5) = 20		(5 x 10) = 50	
				70

INTERNAL EXAMS - 30Marks

(20 mark for unit tests, 5 marks for assignments and remaining 5 marks for seminar etc.)

Practical Paper VII-C

Plant Tissue Culture & Plant Biotechnology

SEMESTER- VI

BOT – 601P

Total hours of teaching 30hrs @ 2hrs per week

Credits: 2

1. (a) Preparation of MS medium.
(b) Demonstration of in vitro sterilization methods and inoculation methods using leaf and nodal explants of Tobacco/ Datura/ Brassica etc.
2. Study of embryo and culture, micro propagation of Banana, somatic embryogenesis, artificial seeds through photographs.
3. Construction of restriction map of circular and linear DNA from the data provided.
4. Study of methods of gene transfer through photographs: Agrobacterium- mediated, directgene

transfer by electroporation, microinjection, and micro projectile bombardment.

5. Different steps involved in genetic engineering for production of Bt. cotton, Golden rice, Flavr Savr tomato through photographs.
6. Isolation of plasmid DNA.
7. Restriction digestion and gel electrophoresis of plasmid DNA (optional)
8. Field visit to a lab involved in tissue culture
9. Study project under supervision of lecturer – tissue culture/ genetic engineering.

Expected domain skills to be achieved: Ability to prepare artificial nutrient media, preparing independently, applying various sterilization procedures for media, glassware and biological materials, invitro propagation of Banana callus, morphogenesis--s, clonal propagation methods, isolation of plasmid DNA individually and as a group.

Practical Paper VII-C
Plant Tissue Culture & Plant Biotechnology

SEMESTER- VI

BOT – 601(GE) P

Total hours of teaching 30hrs @ 2hrs per week

Credits: 2

Q1. Project report (A) -	10M
Viva-voce on study project.....	02M
Q2. Identify and write notes on B, C and D (3x3).....	09 M
B- Tool/instrument/container used in sterilization	
C- Tool/instrument/container used in gene transfer	

D- GM crops (Photographs)

Q3. Construct restriction map of circular and/ or linear DNA from the data
Provided.....06M

Q 4. Field report.....03M

Total.....30 Marks

Internal Assessment

a. Record -05M

b. Attendance.....05M

e. Internal practical exam.....10M

Total... 20Marks

Total ----- 50M

Books for Reference:

1. Pullaiah. T. and M.V.Subba Rao. 2009. Plant Tissue culture. Scientific Publishers, New Delhi.
2. Bhojwani, S.S. and Razdan, M.K., (1996). Plant Tissue Culture: Theory and Practice. Elsevier Science Amsterdam. The Netherlands.
3. Glick, B.R., Pasternak, J.J. (2003). Molecular Biotechnology- Principles and Applications of recombinant DNA. ASM Press, Washington.
4. Bhojwani, S.S. and Bhatnagar, S.P. (2011). The Embryology of Angiosperms. VikasPublicationHouse Pvt. Ltd., New Delhi. 5th edition.

A.G.& S.G. SIDDHARTHA DEGREE COLLEGE OF ARTS & SCIENCE

Vuyyuru - 521165.

NAAC reaccredited at 'A' level

Autonomous -ISO 9001 – 2015 Certified

Title of the Paper: **Plant diversity and Human welfare**

Semester: **VI**

Course Code	BOI - 602	Course Delivery Method	Class Room / Blended Mode - Both
Credits	3	CIA Marks	30
No. of Lecture Hours / Week	4	Semester End Exam Marks	70
Total Number of Lecture Hours	60	Total Marks	100
Year of Introduction :2017-18	Year of Offering: 2019- 20	Year of Revision: ---	Percentage of Revision: ---

Course Objectives:

1. To study plant diversity and its scope
2. To study the loss of biodiversity
3. To study contemporary practices
4. To study the conservation of biodiversity
5. To study the role of plants in relation to human welfare

Course Outcomes: At the end of this course, students should be able to: CO1: Distinguish the levels of biodiversity.

CO2: Explain the loss of biodiversity at different levels.

CO3: Demonstrate contemporary practices in resource management.

CO4: Discuss the conservation of biodiversity.

CO5: Elucidate the role of plants in relation to human welfare.

SYLLABUS

Unit – 1	Plant diversity and its scope: (12hrs) Genetic diversity, Species diversity, Plant diversity at the ecosystem level, Agro biodiversity and Vavilov Crop centers. Values and uses of biodiversity: Ethical and aesthetic values, Uses of plants.
Unit – 2	Loss of biodiversity: (12hrs) Loss of genetic diversity, Loss of species diversity, Loss of ecosystem diversity, Loss of agro biodiversity, projected scenario for biodiversity loss. Management of plant biodiversity: Organizations associated with biodiversity Management-Methodology for execution-IUCN, UNEP, UNESCO, WWF, NBPGR; Biodiversity legislation and conservations, Biodiversity information management and Communication.
Unit – 3	Contemporary practices in resource management: (12hrs) Environmental Impact Assessment (EIA), Geographical Information System GIS, Solid and liquid waste management.
	Conservation of biodiversity (12hrs)

Unit – 4	Conservation of genetic diversity, species diversity. Social approaches to conservation, Biodiversity awareness Programmes, Sustainable development.
Unit – 5	Role of plants in relation to Human Welfare (12hrs) Importance of forestry, their utilization and commercial aspects- a) Avenue trees, b) ornamental plants of India. Fruits and nuts: Important fruit crops their commercial importance. Wood, fiber and their uses.

III B. Sc – BOTANY Model paper (2019-2020)

SEMESTER- VI

Paper – VIII-A-1

PAPER – VIII

PLANT DIVERSITY AND HUMAN WELFARE

Time: 3 Hours

Max. Marks: 70

SECTION-A

Answer any FOUR of the following question

4x5=20M.

1. Species Diversity.
2. Wild Taxa.
3. NBPGR.
4. Biodiversity and its Conservation.
5. EIA.
6. Geographical information system (GIS).
7. Sustainable Development.
8. Fiber and their uses.

SECTION-B

Answer any Five of the following questions.

5 x10=50M.

9. Give a Note on Plant Diversity and its Scope.
10. Write about Values and Uses of Biodiversity.
11. What is Biodiversity? Discuss about the Loss of Biodiversity?
12. Explain the Various Types Organizations in Biodiversity?
13. Write an essay on EIA?
14. Write essays on Solid and Liquid Waste Management?
15. What is Conservation? Explain the In-situ and Ex-situ conservation?
16. What are Fruit crops? Explain their Commercial importance?

Guide lines for paper setter: (for Paper VIII -BOT-602) W.c.f. 2021-22

1. In Section A: Unit I, II, III, must carry Two question from each unit. Unit IV, V must carry one question.
2. In section-B: Set minimum two questions from Unit I, II & III and Set One Question from IV, V.
3. See the following table and Model paper.
4. Please provide the scheme of valuation for the paper.
5. Question paper should be both in English and Telugu media.

Unit	Section - A		Section - B		Weightage in Marks
	Questions	Marks	Questions	Marks	
Unit – I	2		2		
		10		20	30
Unit – II	2		2		

		10		20	30
Unit – III	1		2		
		05		20	25
Unit-IV	1		1		
		5		10	15
Unit-V	2		1		
		10		10	20
Max. Q & marks	8	(x 5) = 40	8	(x 10) = 80	(Total questions = 16) Marks 120
Max. Q and marks for Valuation	Questions	Marks	Questions	Marks	Max. marks
	4		5		
		(4 x 5) = 20		(5 x 10) = 50	70

INTERNAL EXAMS – 30 Marks

(20 mark for unit tests, 5 marks for assignments and remaining 5 marks for seminar etc)

Paper – VIII-A-1: Practicals:

PLANT DIVERSITY AND HUMAN WELFARE

SEMESTER- VI

BOT-602-A-1(CL)P

Time: 3hrs

Max. Marks: 50

- 1) Study of plant diversity (flowering plants).
- 2) Study of exotic species- Identification and morphological characteristics.
- 3) Identification of forest trees through bark, wood, flowers, leaves and fruits.
- 4) Maceration, Study of wood (Tracheary elements, fibres).
- 5) Methods of preservation and canning of fruits.
- 6) Visit to the local ecosystem to study the plants.
- 7) Study of Solid and Liquid waste management systems in rural/urban areas.

SCHEME OF PRACTICAL EXAMINATION

- I. Assign the plants **A, B and C** to their respective families, giving reasons, family name and classification-1marks, important diagrams- 2 marks.....**09 marks**
- II. Give the protocol of **D****04marks**
- III. Comment on specimens **E, F and G****3x3 = 09 marks**
- IV. Report on Field visit..... **4 marks**

To study sources of firewood (10 plants), timber-yielding trees (10 trees) and bamboos.

V. Viva-Voce **04 marks**
Total..... **30 Marks**

Internals

a. Record -05M
b. Attendance.....05M
c. Internal practical exam.....10M
Total..... **20 Marks**

Total -----50M

KEY

A-Cultivated Plant

B- Wild Plant

C –Exotic plant

D- Preservation and canning of fruits, solid and liquid waste management systems in rural/urban areas

E. Bark/wood/fruit yielding plant

F. Nuts/ Alcoholic beverage plant

G. wood /Fibre yielding plant

Paper – VIII-A-1: Practical's:

PLANT DIVERSITY AND HUMAN WELFARE

SEMESTER- VI

BOT-602-A-(CL) P

SCHEME OF PRACTICAL EXAMINATION

Time: 3hrs

Max. Marks: 50

I. Assign the plants **A, B and C** to their respective families, giving reasons, family name and classification-1 marks, important diagrams- 2 marks..... **09 marks**

II. Give the protocol of **D** **04 marks**

III. Comment on specimens **E, F and G** **3x3= 09 marks**

IV. Report on Field visit..... **4 marks**
To study sources of firewood (10 plants), timber-yielding trees (10 trees) and bamboos.

V. Viva-Voce **4 marks**

Total --- 30 marks

Internals:

a. Record -	05M
b. Attendance.....	05M
c. Internal practical exam.....	10M

Total --- 20marks

Total -----50M

KEY

A-Cultivated Plant

B- Wild Plant

C -Exotic plant

D- Preservation and canning of fruits, solid and liquid waste management systems in rural/urban areas

E. Bark/wood/fruit yielding plant

F. Nuts/ Alcoholic beverage plant

G. wood /Fibre yielding plant

Suggested Readings:

1. Krishnamurthy, K.V. (2004). An Advanced Text Book of Biodiversity - Principles and Practices. Oxford and IBH Publications Co. Pvt. Ltd. New Delhi.
2. Singh, J. S., Singh, S.P. and Gupta, S. (2006). Ecology, Environment and Resource Conservation. Anamaya Publications, New Delhi.
3. Rogers, P.P., Jalal, K.F. and Boyd, J.A. (2008). An Introduction to Sustainable Development. Prentice Hall of India Private Limited, New Delhi.

A.G.& S.G. SIDDHARTHA DEGREE COLLEGE OF ARTS & SCIENCE

Vuyyuru - 521165.

NAAC reaccruited at 'A' level

Autonomous -ISO 9001 – 2015 Certified

Title of the Paper: **Ethno Botany and Medicinal Botany**

Semester: **VI**

Course Code	BOT - 603	Course Delivery Method	Class Room / Blended Mode - Both
Credits	3	CIA Marks	30
No. of Lecture Hours / Week	4	Semester End Exam Marks	70
Total Number of Lecture Hours	60	Total Marks	100
Year of Introduction :2017-18	Year of Offering: 2019- 20	Year of Revision: --	Percentage of Revision: --

Course Objectives:

1. To learn about ethnobotany
2. To learn about the role of ethnobotany in modern medicine
3. To learn the ethnobotany as a tool to protect interests of ethnic groups
4. To study the history, scope and importance of medicinal plants in indigenous medicinal sciences
5. To study the conservation of endangered and endemic medicinal plants

Course Outcomes: At the end of this course, students should be able to:

CO1: Analyze the concept, scope and objectives.

CO2: Explain the role of ethnobotany in modern medicine.

CO3: Demonstrate ethnobotany as a tool to protect interests of ethnic groups.

CO4: Discuss the history scope and importance of medicinal plants in indigenous medicinal sciences.

CO5: Elucidate the conservation of endangered and endemic medicinal plants

SYLLABUS

Unit – 1	<p>Ethnobotany (12hrs)</p> <p>Introduction, concept, scope and objectives</p> <p>Major and minor ethnic groups or Tribal's of India, and their lifestyles.</p> <p>Plants used by the tribal populations:</p> <p>a) Food plants, b) Intoxicants</p> <p>c) Beverages, d) Resins and oils and miscellaneous uses.</p>
Unit – 2	<p>Role of ethnobotany in modern Medicine (12hrs)</p> <p>Role of Ethnobotany in modern medicine with special example; Rauwolfia serpentina, Artemisia annua, Withania somnifera.</p> <p>Significance of the following plants in ethno botanical practices (along with their habitat and morphology)</p> <p>a) Azadirachta indica, b) Vitex negundo, c) Ocimum sanctum, d) Phyllanthus niruri</p> <p>Medico-Ethnobotanical Sources of India.</p>
Unit – 3	<p>Ethno botany as a tool to protect interests of ethnic groups (12hrs)</p> <p>Sharing of wealth concept with few examples from India.</p> <p>Biopiracy, Intellectual Property Rights and Traditional Knowledge</p>
	<p>History, Scope and Importance of Medicinal Plants, Indigenous Medicinal Sciences (12hrs)</p> <p>Definition and Scope-Ayurveda: History, origin, panchamahabhutas, saptadhatu and</p>

Unit – 4	tridosha concepts, Rasayana, plants used in ayurvedic treatments. Homeopathy: Origin of Homeopathy medicinal systems, Basis of Homeopathy, plants used in Homeopathy medicine.
Unit – 5	Conservation of endangered and endemic medicinal plants (12hrs) Definition: endemic and endangered medicinal plants. 2. Red list criteria In situ conservation: Sacred groves, National Parks. Ex situ conservation: Botanical Gardens, Seed Banks.

III B. Sc – BOTANY Model paper (2021-2022)

Title of the Paper: **ETHNOBOTANY AND MEDICINAL BOTANY**

SEMESTER- VI PAPER – VIII Cluster – A **Paper – VIII-A-2**

Time: 3 Hours

Max. Marks: 70

SECTION-A

Answer any FOUR of the following question

4x5=20M.

1. Intoxicants.
2. Withania somnifera.
3. Phyllanthus niruri
4. Curcuma langa.
5. Biopiracy
6. Saptdhatu and Tridosha.
7. Tumors treatments.
8. Red list criteria.

SECTION-B

Answer any Five of the following questions.

5x10 =50M.

9. Explain the Relevance of Ethno-Botany in the present Context.

10. Discuss about Major and Minor Ethnic groups of India.
11. Write about Botanical name, Family, Active principle and medicinal uses of Rauvolfia serpentina, Artemisia annua.
12. Write about the Medico-Ethnobotanical Sources of India.
13. Write about the Intellectual property rights and Traditional knowledge.
14. Write an Essay on Basic concepts of Ayurveda.
15. What is Siddha System of Medicine? Explain their Basic Concepts?
16. Give an account of Endemic and Endangered Medicinal plants ?

Guide lines for paper setter: (for Paper VIII-BOT-603(CE)) W.e.f. 2021-22

1. In Section A: Unit I, IV, must carry two questions from each unit. Unit II must carry Two Question. Unit III, V must carry one question.
2. In section-B: Set minimum Two questions from Unit I, II & IV and Set One Question from III, V.
3. See the following table and Model paper.
4. Please provide the scheme of valuation for the paper.
5. Question paper should be both in English and Telugu media.

Unit	Section - A		Section - B		Weightage in Marks
	Questions	Marks	Questions	Marks	
Unit – I	2		2		
		10		20	30
Unit – II	2		2		
		10		20	30

Unit – III	1	1			
		05	10	15	
Unit-IV	2	2			
		10	20	30	
Unit-V	1	1			
		5	10	15	
Max. Q & marks	8	(x 5) = 40	8	(x 10) = 80	(Total questions = 16) Marks 120
Max. Q and marks for Valuation	Questions	Marks	Questions	Marks	Max. marks
	4		5		
		(4 x 5) = 20		(5 x 10) = 50	70

INTERNAL EXAMS - 30Marks

(20 mark for unit tests, 5 marks for assignments and remaining 5 marks for seminar etc.).

**III B. Sc – Practical Paper
ETHNOBOTANY AND MEDICINAL BOTANY**

**SEMESTER- VI
Time: 3 Hours**

**BOT-VIII-603-A- 2(CL)P
Max. Marks- 50**

1. Ethno botanical specimens as prescribed in theory syllabus
2. Detailed morphological and anatomical study of medicinally important part(s) of locally available plants (Minimum 8 plants) used in traditional medicine.
3. Field visits to identify and collect ethno medicinal plants used by local tribes/folklore.

Practical Question Paper

- I. Identify the specimen A- Give reasons (morphological and anatomical) and draw Labeled sketches10marks
- II. Identify and write about the medicinal uses of B and C.....2x4 = 08 marks
- III. Comment on D and E.....2 x 2= 04 marks
- IV. Report on Field visit:.....04 marks
List to be prepared mentioning special features of plants used by tribal Populations as Medicinal Plants & Spices. Write their botanical and common names, Parts used and diseases/disorders for which they are prescribed.
- V. Viva-voce..... 04 marks
- Total.....30Marks**

Internals Assessment

a. Record -	05M
b. Attendance.....	05M
c. Internal practical exam.....	10M
Total.....	<u>20 Marks</u>

Total-----50Marks

KEY

A-Plants given in unit II (i)

B-Plants used in Ayurvedic preparations (Amla in Chyavanprash, Senna in Laxatives)

C - - Do -

D. Photographs of National parks, Biosphere reserves and Botanical gardens.

E. Photograph of famous personalities in Ayurveda/Siddha medicine.

Suggested Readings:

- 1) S.K. Jain, Manual of Ethnobotany, Scientific Publishers, Jodhpur, 1995.
- 2) Glimpses of Indian. Ethnobotny, Oxford and I B H, New Delhi – 1981.
- 3) S.K. Jain (ed.) 1989. Methods and approaches in ethnobotany. Society of ethnobotanists, Lucknow, India.
- 4) S.K. Jain, 1990. Contributions of Indian ethnobotny. Scientific publishers, Jodhpur.
- 5) Colton C.M. 1997. Ethnobotany – Principles and applications. John Wiley and sons Chichester

A.G.& S.G. SIDDHARTHA DEGREE COLLEGE OF ARTS & SCIENCE

Vuyyuru - 521165.

NAAC reaccredited at 'A' level

Autonomous -ISO 9001 – 2015 Certified

Title of the Paper: **Pharmacognosy and Phytochemistry**

Semester: **VI**

Course Code	BOI - 604	Course Delivery Method	Class Room / Blended Mode - Both
Credits	3	CIA Marks	30
No. of Lecture Hours / Week	4	Semester End Exam Marks	70
Total Number of Lecture Hours	60	Total Marks	100
Year of Introduction :2017-18	Year of Offering: 2019- 20	Year of Revision: --	Percentage of Revision: --

Course Objectives:

1. The study of pharmacognosy.

2. The study of organoleptic and microscopic studies.
3. Knowledge of secondary metabolites.
4. Study of phytochemistry
5. Knowledge of enzymes, proteins and amino acids.

Course Outcomes: At the end of this course, students should be able to:

- CO1: Remember the importance of pharmacognosy.
 CO2: Understand organoleptic and microscopic studies with reference to nature of active principles and common adulterants of certain species.
 CO3: Apply detailed account of acetate pathway, mevalonate pathway and shikimate pathway.
 CO4: Analyze the importance of phytochemicals.
 CO5: Evaluate the biological importance of secondary metabolites.
 CO6: Create enzymes proteins and amino acids as drugs.

SYLLABUS

Unit – 1	Pharmacognosy Definition, Importance Classification of drugs - Chemical and Pharmacological Drug evaluation methods	(12hrs)
Unit – 2	Organoleptic and microscopic studies: Organoleptic and microscopic studies with reference to nature of active principles and common adulterants of a) Adhatoda vasica(leaf) b) Strychnosnuxvomica (seed), c)Rauwolfia serpentina(root) d)Zinziberofficinalis e)Catharanthusroseus.	(12hrs)
Unit – 3	Secondary Metabolites Definition of primary and secondary metabolites and their differences, Major types - terpenes, Phenolics, alkaloids, terpenoids, steroids .A brief idea about extraction of alkaloids. Origin of secondary metabolites–detailed account of Mevalonate pathway, Shikimate pathway.	(12hrs)
Unit – 4	Phytochemistry: Biosynthesis and sources of drugs: Structural type biosynthesis importance of simple Phenolic compounds, coumarins, Flavonoids. Steroids, sterols: Biosynthesis, commercial importance. Alkaloids: Different groups, biosynthesis, bioactivity. Volatile oils, aromatherapy.	(12hrs)
Unit – 5	Enzymes, proteins and amino acids as drugs: Vaccines, toxins and toxoids, immune globulins, antiserums, Vitamins, Antibiotics – chemical nature, mode of action. Pharmacological action of plant drugs – tumor inhibitors, PAF antagonists, antioxidants,	(12hrs)

III B. Sc – BOTANY Model paper (2021-2022)

SEMESTER- VI

PAPER – VIII Cluster – A

Paper – VIII-A-3: Title of the Paper: **Pharmacognosy and Photochemistry**

Time: 3 Hours

Max. Marks: 75

SECTION-A

Answer any FOUR of the following question

4x5=20M.

1. Classification of Drugs.
2. Catharanthus roseus.
3. Difference between Primary and Secondary Metabolites.
4. Terpenoids.
5. Flavonoids.
6. Aromatherapy
7. Vaccines.
8. Vitamins.

SECTION-B

Answer any Five of the following questions.

5x10=50M.

9. Give an account on Pharmacognosy ?
10. Write an essay on Drug Evolution methods ?
11. Write about nature and Active principles of *Adhatda vasica*, *Rauwfia serpentine* ?
12. Write about common Adulteration of *Zanzibar officinalis*, *Strychnos nuxvomica* ?
13. Give an Brief note on Extraction of Alkalods ?
14. Give an account of Acetate pathway ?
15. Write about Bio-Synthesis and Commercial importance of Steroids, Sterols, Cucurbitacins ?
16. Explain the role of Different Enzyme inhibitors ?

Guide lines for paper setter: (for Paper VI-BOT-604) W.e.f. 2021-22.

1. In Section A: Unit III, IV, V must carry two questions from each unit. Unit I, II, must carry One question.
2. In section-B: Set minimum two questions from Unit I, II & III and Set One Question from IV, V.
3. See the following table and Model paper.
4. Please provide the scheme of valuation for the paper.
5. Question paper should be both in English and Telugu media.

Unit	Section - A		Section - B		Weightage in
	Questions	Marks	Questions	Marks	Marks
Unit – I	1		2		
		5		20	25
Unit – II	1		2		
		5		20	25

Unit – III	2	2			
		10	20	30	
Unit-IV	2	1			
		10	10	20	
Unit-V	2	1			
		10	10	20	
Max. Q & marks	8	(x 5) = 40	8	(x 10) = 80	(Total questions = 16) Marks 120
Max. Q and marks for Valuation	Questions	Marks	Questions	Mark s	Max. marks
	4		5		
		(4 x 5) = 20		(5 x 10) = 50	70

INTERNAL EXAMS - 30Mark

(20 mark for unit tests, 5 marks for assignments and remaining 5 marks for seminar etc.)

Pharmacognosy and Phytochemistry

SEMESTER- VI
Time: 3 Hours

BOT-VIII-604-A- 3 (CL)P
Max. Marks- 50

1. Physical and chemical tests for evaluation of unorganized drugs- Asaphoetida. Honey, Castor oil. Acacia
2. Identification of bark drugs – cinchona, cinnamom
3. Identification of fruit drugs – Cardamom, Coriander
4. Identification of root and rhizome drugs- Ginger, Garlic, Turmeric
5. Identification of whole plant – Aloes, Vinca, Punarnava
6. Herbarium of medicinal plants (minimum of 20 platns)
7. Collection of locally available crude drugs from local venders (minimum of 20)

Practical Question Paper

- I. Identify the given crude drugs **A & B** by Anatomical study and Morphological Study.....**2X5 = 10marks**
- II. Perform suitable chemical test and identify the given phytochemical **C**.....**05marks**

III. Comment on D and E2x3= 06 marks

IV. Herbarium and submission of drugs -.....5 marks

IV. Viva-Voce04 marks

Total..... **30Marks**

Internals

a. Record -05M

b. Attendance.....05M

c. Internal practical exam.....10M

Total.....**20Marks**

Total -----50M

KEY

A-Flower/fruit drugs

B-Rhizome/whole plant drugs

C- Tannins/ phenolics/steroids/ isoprenoids /Asaphoetida/ Honey/ Castor oil/ Acacia

D. Column Chromatography/ Gas Chromatogram/HPLC (photograph/ instrument used for chemical analysis of drugs.

BOOKS FOR REFERENCE:

1. Wallis, T. E. 1946. Text book of Pharmacognosy, J & A Churchill Ltd. 2. Roseline, A. 2011. Pharmacognosy. MJP Publishers, Chennai.
2. Gurdeep Chatwal, 1980. Organic chemistry of natural productis. Vol.I.Himalaya Publishing house.
3. Kalsi, P. S. and Jagtap, S., 2012. Pharmaceutical medicinal and natural Product chemistry N.K. Mehra . Narosa Publishing House Pvt. Ltd. New Delhi.
4. Agarwal, O. P. 2002. Organic chemistry–Chemistry of organic natural products. Vol. II. Goel publishing house , Meerut.

A.G.& S.G. SIDDHARTHA DEGREE COLLEGE OF ARTS & SCIENCE

Vuyyuru - 521165.

NAAC re accredited at 'A' level

Autonomous -ISO 9001 – 2015 Certified

Title of the Paper: Plant Nursery Management

Offered to: BSc. BZC,AQU

Course Type: SDC

Year of Introduction: 2021-22

Year of Revision: --

Percentage of Revision: —

Semester: II

Credits: 02

Hours Taught: 30 hrs. Per Semester
Hours

Hours per week: 2

Course Prerequisites: Knowledge of herbarium methodology studied in intermediate. **Course Description:** This course will provide one with a basic and comprehensive understanding of herbarium. Enable the student with depth of topics and helps them to gain an appreciation in collection and processing of specimens. On the other hand, importance of understanding maintenance of herbarium, handling of specimens provides an extensive knowledge to the student.

Course Objectives:

1. To study importance of nursery.
2. To study the basic requirements for nursery.
3. To study the management of nursery.
4. To study seasonal activities and routine operations in a nursery.
5. To study vegetative propagation techniques.

Course Outcomes: At the end of this course, students should be able to:

CO1: Understand the importance of plant nursery, basic infrastructure to establish it. CO2: Explain the basic material, tools and techniques required for nursery.

CO3: Demonstrate expertise related to various practices in a nursery

CO4: Comprehend knowledge and skills to get an employment or to become an entrepreneur in plant nursery sector.

Syllabus

Course Details

Unit	Learning Units	Lecture Hours
I	Introduction to Plant Nursery 1. Plant nursery: definition, importance. 2. Different types of nurseries on the basis of duration, plant parts used for propagation. 3. Basic facilities for a nursery: layout and components of a good nursery 4. Plant propagation structures in brief 5. Bureau of Indian standards (BIS-2008) related to nursery.	6
II	Basic Requirements for Nursery 1. Nursery beds – types and precautions to be taken during preparation. 2. Growing media, nursery tools and implements, containers for plant nursery in brief. 3. Outlines of vegetative propagation techniques to produce planting material. 4. Sowing methods of seeds and planting material.	6
III	Management of Nursery 1. Seasonal activities and routine operations in a nursery. 2. Nursery management- watering, weeding and nutrients: pests and diseases. 3. Common possible errors in nursery activities. 4. Economics of nursery development, pricing and record maintenance. Online nursery information and sales systems.	6

Recommended Reference book:

1.Ratha Krishnan, M., et..al (2014) plant nursery management: principles and practices, Central arid Zone Research Institute (ICAR), Jodhpur, Rajasthan.

2.Kumar, N., (1997) Introduction to Horticulture, Rajalakshmi Publications Nagercoil.

3.Kumar Mishra.,N.K. Mishra and Satish Chand (1994) Plant Propagation, John Wiley & Sons. New Jersey

Course Delivery method: Face-to-face / Blended.

Course has focus on: Foundation/Skill Development

Websites of Interest: <https://youtu.be/Y6BgWWPFGss>

<https://www.youtube.com/watch?v=9Dc-NYGz-9w>.

MODEL QUESTION PAPER

PLANT NURSERY MANAGEMENT

Time: 2hrs

Max. Marks: 40

SECTION- A

2x5M=10 M

**Answer any TWO questions. Each answer carries 5 marks
(At least 1 question should be given from each Unit)**

1. Write a short note on Nursery.
2. Soil sterilization
3. Bio pesticides
4. Seed Scarification

SECTION B

3x10M = 30 M

Answer any three questions. Each answer carries 10 marks

(At least TWO question should be given from each Unit)

1. Write an essay on components of Model nursery?
2. Write an essay on Bureau of Indian Standards related to nursery?
3. Write an essay on Growing media?
4. What is layering? Explain different types of layering?
5. Write about nursery management?
6. Explain about Nursery diseases and their management?

**A.G & S.G.SIDDHARTHA DEGREE COLLEGE OF ARTS & SCIENCE
VUYYURU-521165, KRISHNA Dt., A.P. (Autonomous)**

Accredited by NAAC with "A" Grade



**DEPARTMENT OF ZOOLOGY
MINUTES OF BOARD OF STUDIES
ODD SEMESTER
01-11-2021**







Minutes of the meeting of Board of studies in Zoology for the Autonomous courses of AG & SG Siddhartha Degree College of Arts & Science, Vuyyuru, held at 2:30 pm on 01-11-2021 in the Department of Zoology.

Smt.D.A. Kiranmayee. ...

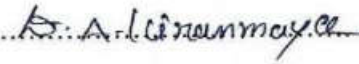
Presiding

Members Present:

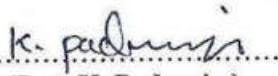
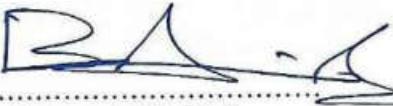
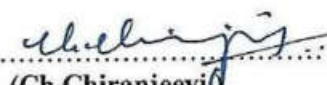
- 1)  Chair person Head, Department of Zoology,
(Smt. D.A.Kiranmayee.) A.G&S.G.S Degree College of
Vuyyuru-521165.
- 2)  University Nominee Bio Sciences & Bio technology
(Smt. Dr.L.Suseela.) Krishna University
Machilipatnam.
- 3)  Academic Council Head,Department of Zoology,
(Sri Dr.M.Viyay kumar.) Nominee SRR & CVR Govt. Degree College,
Vijayawada.
- 4)  Academic Council Head, Department of Zoology,
(Sri Ch. Venkateswaralu.) Nomine P.B. Siddhartha College,
Vijayawada.
- 5)  Member Lecturer in Zoology,
(Smt. K. Padmaja.) A.G&S.G.S Degree College
Vuyyuru-521165.
- 6)  Industrialist Asst. Project Manager,
(B. Appala Naidu.) RGCA
Manikonda.
- 7)  Student Represent P.hd –Research Scholar,
(Ch.Chiranjeevi) Dept.of Botany & Microbiology,
Acharya Nagarjuna University,
Guntur.

ZOOLOGY

Agenda for B.O.S Meeting.

1. To recommend the syllabi (Theory & Practical), Model question paper for I Semester of I B.Sc (B.Z.C) for the academic year 2021 - 2022.
2. To recommend the syllabi (Theory & Practical), Model question paper for III Semester of II B.Sc (B.Z.C) for the academic year 2021 - 2022.
3. To recommend the syllabi (Theory & Practical), Model question paper for V Semester of III B.Sc (B.Z.C) for the academic year 2021 - 2022.
4. To recommend the Blue print for the semester end exam for I, III & V semester of I, II, III B.Sc (B.Z.C) for the academic year 2021 - 2022.
5. To introduce Life Skill Course Environmental Studies for I year students in this academic year 2021-22.
6. To introduce Skill Development Course Poultry Farming for III year students in this academic year 2021-22.
7. To recommend the teaching and evolution methods to be followed under Autonomous statues.
8. Any other matter.

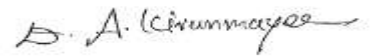

Chairman

ZOOLOGY- RESOLUTIONS

1. It is resolved to continue the changed syllabi (Theory & Practical), model question paper & guide lines to be followed by the question paper setters of Zoology of I semester of I B.Sc. (B.Z.C) under Choice Based Credit System (CBCS) approved by the Academic Council of 2021 – 2022.
2. It is resolved to implement **the new paper Cell Biology, Genetics, Molecular Biology & Organic Evolution** (Theory & Practical), to be followed under Choice Based Credit System (CBCS) in Zoology of III Semester of II B.Sc. (B.Z.C) approved by the Academic Council of 2021 – 2022.
3. It is resolved to implement the same syllabi & model papers under Choice Based Credit System (CBCS) Setters of Zoology of V semester of III B.Sc. (B.Z.C) approved by the Academic Council of 2021-2022.
4. It is resolved to Continue the same Blue prints of I, III, & V Semesters of B.Sc Zoology for the Academic year 2021-2022.
5. It is resolved to implement Life skill Course for I year students.
6. It is resolved to implement Skill Development Course for II year students.
7. It is resolved to continue the following teaching & evolution methods for the Academic year 2021-22.
8. Any other matter.

Teaching methods:

Besides the conventional methods of teaching, we use modern technology i.e. Using of OHP and LCD projector to display on U boards etc; for better understanding of concepts.

Evaluation of a student is done by the following procedure:

❖ Internal Assessment Examination:

- ❖ Out of maximum 100 marks in each paper for II, III B.Sc, 30 marks shall be allocated for internal assessment.
- ❖ Out of these 30 marks, 20 marks are allocated for announced tests (i.e . IA-1& IA-2). Two announced tests will be conducted and average of these two tests shall be deemed as the marks obtained by the student, 5 marks are allocated on the basis of candidate's percentage of attendance and remaining 5 marks are allocated for the assignment for II, III B.SC.
- ❖ Out of maximum 100 marks in each paper for I B.Sc, 25 marks shall be allocated for internal assessment.
- ❖ Out of these 25 marks, 20 marks are allocated for announced tests (i.e . IA-1& IA-2). Two announced tests will be conducted and average of these two tests shall be deemed as the marks obtained by the student, 5marks allocated on the basis of candidate's percentage of attendance / assignment for I semester.
- ❖ There is no pass minimum for internal assessment for I, II, III B.Sc

❖ Semester – End Examination:

- ❖ The maximum mark for I (BZC) semester – End examination shall be 75 marks and duration of the examination shall be 3 hours.
- ❖ The maximum mark for II, III B.Sc semester- End examination shall be 70 marks and duration of the examination shall be 3 hours. Even though the candidate is absent for two IA exams / obtain zero marks the external marks are considered (if the candidate gets 40/70) and the result shall be declared as “PASS”
- ❖ Semester – End examination shall be conducted in theory papers at the end of every semester, while in practical papers, these examinations are conducted at the end of I, III, & V semester for I, II & III B.Sc.
- ❖ Discussed and recommended for organizing Seminars, Guest lectures, Work – Shops to upgrade the Knowledge of students, for the approval of the Academic Council.

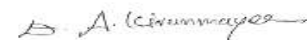

Chairman

ADUSUMILLI GOPALAKRISHNAIAH & SUGAR CANE GROWERS SIDDHARTHA DEGREE COLLEGE OF ARTS & SCIENCE, VUYYURU-521165, KRISHNA Dt., A.P. (AUTONOMOUS).

ALLOCATION OF CREDITS

For the Papers offered during I,III & V Semesters

<i>Year</i>	<i>Semester</i>	<i>Title</i>	<i>Teaching hours</i>	<i>Internal marks</i>	<i>External marks</i>	<i>Credits</i>
I	I	Animal Diversity – I Biology of Non-Chordates	4	25	75	03
		Animal Diversity -Biology of Non-Chordates – Practical - I	2	10	40	01
II	III	Cell Biology, Genetics, Molecular biology & Evolution	4	30	70	03
		Practical Cell Biology, Genetics, Molecular biology & Evolution	2	25	25	01
III	V(501)	Animal Bio technology	4	30	70	03
		Practical – 501p Animal Bio technology	2	25	25	01
	V(502)	Animal Husbandry	4	30	70	03
		Practical – 502p Animal Husbandry	2	25	25	01
		Total Credits				16

**ADUSUMILLI GOPALAKRISHNAIAH & SUGAR CANE GROWERS SIDDHARTHA DEGREE COLLEGE
OF ARTS & SCIENCE, VUYYURU-521165, KRISHNA Dt., A.P. (AUTONOMOUS).**

NACC reaccredited at 'A' level

Autonomous –ISO 9001-2015 Certified

Title of the Paper: **Animal Diversity Biology of Non – Chordates**

Semester: - I

Course Code	ZOOT11A	Course Delivery Method	Class Room/Blended Mode - Both
Credits	3	CIA Marks	25
No. of Lecture Hours/ Week	4	Semester End Exam Marks	75
Total Number of Lecture Hours	60	Total Marks	100
Year of Introduction : 2017-18	Year of Offering 2021-2022	Year of Revision – 2021-22	Percentage of Revision: 0%

AIM

- To know the biodiversity of invertebrates

LEARNING OBJECTIVES

- To understand the structural organization of animals from Protozoa to Hemichordate
 - To understand the evolutionary relationship of different phyla from Protozoa to Hemichordate
 - To understand the specific phenomena exhibited by different groups of invertebrates from Protozoa to Hemichordate
 - To understand the taxonomic position and affinities of certain groups of invertebrates
- AsConnecting links
- To study the life cycles, and pathogenicity of certain

PREREQUISITE

- Knowledge of invertebrates acquired in Intermediate

COURSE OUTCOMES

By the end of the course students will be able to

CO 1 Gain knowledge in the fundamental concepts underlying the structural complexity in the organization of invertebrates.

CO 2 Understand biology and pathogenicity of parasites and their adaptations analyse remedial and preventive measures and promote the same in public domain.

CO 3 Appreciate and evaluate the economic, commercial, medicinal and culture importance of invertebrates and their larval stages in relation to phylogeny

CO 4 Describe the significance of connecting links in understanding the concept of evolution

CO 5 Explain the significance of specific phenomena in different group's of invertebrates in relation to their adaptability for survival

CO 6 Comprehend the systems biology of individual phyla with a specific type study and understand the origin and evolutionary relationship of different phyla and appreciate the uniqueness of individual phyla.

Syllabus
Course Details

Unit	Learning Units	Lecture Hours
I	<p>PROTOZOA AND PORIFERA Introduction to Non-chordates – Origin of metazoans Type study: <i>Polystomella</i>(structure and life cycle) Locomotion in protozoans Nutrition in protozoans Type study: <i>Sycon</i>(Structure, histology and skeleton) Canal system in sponges</p>	13
II	<p>CNIDARIA AND CTENOPHORA Type study: <i>Obelia</i>. (Structure – polyp and medusa and life cycle) Polymorphism in cnidarians. Corals and coral reefs Ctenophora (structure and affinities)</p>	10
III	<p>HELMINTHES AND ANNELIDA Type study: <i>Fasciola hepatica</i> (Structure, reproduction, life cycle and pathogenicity) Parasitic adaptations in helminthes Type study: <i>Ascarislumbricoides</i>(Structure, reproduction, life cycle and pathogenicity) Type study: <i>Hirudinaria</i>(Structure, circulatory, excretory and reproductive systems) Coelom and coelomoducts in annelids</p>	17
IV	<p>ARTHROPODA AND MOLLUSCA Structural affinities of Onychophora Type study: <i>Macrobrachiumrosenbergii</i>(Structure, appendages and Respiratory system) Economic importance of insects (Beneficial – Lac insect, honey bee, <i>Bombyxmori</i>and Lady bird; Harmful – house fly, mosquito, locustand bedbug) Metamorphosis in insects Study of Pearl Oyster and Pearl Formation Torsion in gastropods</p>	14
V	<p>ECHINODERMATA AND HEMICHORDATA Water-vascular system Echinoderm larvae <i>Balanoglossus</i>- Structure and affinities</p>	6

TEXTBOOKS

1. R.L. Kotpal, *Modern Text Book of Zoology - Invertebrates*.
2. P.S. Dhami and J.K. Dhami *Invertebrate Zoology*.

SUGGESTED READINGS

1. L.H. Hyman, '*The Invertebrates*' Vol I, II and V. – M.C. Graw Hill Company Ltd.
2. Ruppert, Fox and Barnes, *Invertebrate Zoology - A Functional Evolutionary Approach* - Thomas Publishers. Indian Edition.
3. E.L. Jordan and P.S. Verma '*Invertebrate Zoology*' S. Chand and Company.
4. R.D. Barnes '*Invertebrate Zoology*' by: W.B. Saunders CO., 1986.
5. Barrington. E.J.W. '*Invertebrate Structure and Function*' by ELBS.
6. Sedgwick. A. '*A Student Text Book of Zoology*' Vol-I, II and III – Central Book Depot, Allahabad.

CO-CURRICULAR ACTIVITIES

- Preparation of chart/model of *Elphidium* life cycle
- Visit to Zoology museum or Coral island as part of Zoological tour
- Charts on life cycle of *Obelia*, polymorphism, sponge spicules
- Clay models of canal system in sponges
- Preparation of charts on life cycles of *Fasciola* and *Ascaris*
- Visit to adopted village and conducting awareness campaign on diseases, to people as part of Social Responsibility.
- Plaster-of-Paris or Thermocol model of *Peripatus*
- Construction of a vermicompost in each college, manufacture of manure by students and donating to local farmers
- Models of compound eye, bee hive and termitarium (termitaria) by students
- Visit to apiculture centre and short-term training as part of apprenticeship programme of the govt. of Andhra Pradesh
- Chart on pearl forming layers using clay or Thermocol
- Visit to a pearl culture rearing industry/institute
- Live model of water vascular system
- Phylogeny chart on echinoderm larvae and their evolutionary significance
- Preparation of charts depicting the feeding mechanism, 3 coeloms, tornaria larva etc., of *Balanoglossus*

I SEMESTER END EXAMINATIONS

PAPER – I MODEL PAPER *Cours Code: ZOOT11A*

Title of the paper: Animal Diversity Biology of Non – Chordates

Time: 3 Hours

Max. Marks: 75

SECTION –A

Draw neat labeled diagrams wherever necessary.

Answer and FIVE of the following

5x5=25 Marks

1. Describe the structure of *Polystomella* CO 1, L1
2. List out/state the different types of cells in sponges CO1, L1
3. Describe *Obelia* medusa CO1, L1
4. Describe Flame cells in *Fasciola hepatica* CO1, L1
5. Explain the significance of coelom in annelids CO2, L2
6. Explain bipinnaria larva in relation to phylogeny CO3, L2
7. Explain the process of pearl formation and its significance CO5, L2
8. *Peripatus* is a connecting link. Analyze. CO4, L4

SECTION – B

Answer the following questions.

5X10=50 Marks

9. Explain the different types of nutrition in protozoans. CO5, L2
OR
Explain the different types of canal system in sponges. CO5, L2
10. Evaluate the process of metagenesis in the life cycle of *Obelia*. CO1, L5
OR
Evaluate how ctenophores differ structurally from cnidarians. CO1, L5
11. Describe the life cycle of *Ascaris lumbricoides*. CO2, L2
OR
Describe the reproductive system of *Hirudinaria*. CO2, L2
12. Enumerate the economic importance of insects CO3, L1
OR
Describe torsion in gastropods as significant in larval development CO3, L1
13. Analyze the functional suitability of water vascular system in echinoderms CO5, L4
OR
Examine the structural affinities of *Balanoglossus*. CO4, L4

PRACTICAL- I (At the end of I Semester)

Title of the paper: Animal Diversity Biology of Non – Chordates

No of Hours: 30

Credits: 01

WEF: 2021-2022 Course Code: ZOO P11A

LEARNING OUTCOMES:

By the end of the course students will be able to

1. Understand the general characters and classification from Protozoa to Hemichordata
2. Understand the importance of preservation of museum specimens
3. Identify animals based on special identifying characters
4. Understand different organ systems through demo or virtual dissections
5. Maintain a neat, labeled record of identified museum specimens
6. Exhibit the hidden creative talent

COURSE OUTCOMES

CO1 To identify the characteristics and systematic position of protozoans and poriferans PO1, PO2, PO5, PO6, PO7, PSO1

CO2 To identify the characteristics and systematic position of Cnidarians and Helmenthes. PO1, PO2, PO5, PO6, PO7, PSO1

CO3 To identify the characteristics and systematic position of Annelids, Arthropodans and Molluscans. PO1, PO2, PO5, PO6, PO7, PSO1

CO4 To identify the characteristics and systematic position of Echinoderms and hemichordates. PO1, PO2, PO5, PO6, PO7, PSO1

CO5 To understand the various systems of Prawn by Dissecting and Mounting its appendages. PO1, PO2, PO5, PO6, PO7, PSO1

Syllabus
Course Details

Unit	Learning Units
Syllabus	General characters and classification of the following phyla and sub-phyla up to classes with suitable examples: Protozoa, Porifera, Cnidaria, Platyhelminthes, Nematoda, Annelida, Arthropoda, Mollusca, Echinodermata and Hemichordata.
I	<p>SPOTTERS</p> <p>Porifera: <i>Euspongia</i>, <i>Spongilla</i>, <i>Sycon</i>. Cnidaria: <i>Physalia</i>, <i>Velella</i>, <i>Aurelia</i>, <i>Gorgonia</i>, <i>Pennatula</i>. Annelida: <i>Nereis</i>, <i>Heteronereis</i>, <i>Aphrodite</i>, <i>Hirudineria</i>. Arthropoda: <i>Scylla</i>, <i>Macrobrachium</i>, <i>Scolopendra</i>, <i>Sacculina</i>, <i>Limulus</i>, <i>Scorpion</i>, <i>Peripatus</i>. Mollusca: <i>Chiton</i>, <i>Murex</i>, <i>Unio</i>, <i>Sepia</i>, <i>Loligo</i>, <i>Octopus</i>, <i>Nautilus</i>. Echinodermata: <i>Asterias</i>, <i>Ophiothrix</i>, <i>Echinus</i>, <i>Clypeaster</i>, <i>Cucumaria</i>, <i>Antedon</i>. Hemichordata: <i>Balanoglossus</i></p>
II	<p>SLIDES</p> <p>Protozoa: <i>Elphidium</i>, <i>Paramoecium</i>, <i>Paramoecium</i> - Binary fission and conjugation, <i>Vorticella</i>, <i>Entamoebahistolytica</i>, <i>Plasmodium vivax</i> Porifera: T.S and L.S. of <i>Sycon</i>, spicules, gemmule Cnidaria: <i>Obeliacolony</i> and medusa, Platyhelminthes: <i>Planaria</i>, <i>Fasciola hepatica</i>, <i>Fasciolalarval</i> forms (Miracidium, Redia, Cercaria) <i>Echinococcusgranulosus</i>, <i>Taeniasolium</i> Nematoda: <i>Ascarislumbricoides</i> (male and female), <i>Ancylostomaduodenale</i> (male and female), <i>Dracunculus</i>, <i>Wuchereria</i> Annelida: Trochophore larva Arthropoda: Mouthparts of housefly, butter fly, male and female <i>Anopheles</i> and <i>Culex</i>, Crustacean larvae (nauplius, mysis, zoea) Mollusca: Glochidium larva Echinodermata: Bipinnarialarva Hemichordata: Tornaria larva</p>
III	<p>DEMONSTRATION OF DISSECTIONS</p> <p>1. Prawn: Nervous system Mounting of statocyst Mounting of appendages 2. Mounting of Insect mouth parts</p> <ul style="list-style-type: none"> • Animal Album to be submitted at the time of practical examination • Laboratory Record Book to be submitted at the time of practical examination

Suggested Manuals

1. Practical Zoology- Invertebrates S.S.Lal
2. Practical Zoology - Invertebrates P.S.Verma
3. Practical Zoology K.P.Kurl

I B.Sc. ZOOLOGY PRACTICAL EXAMINATION

Practical - I

Course Code: ZOO P11A

Title of the paper: Animal Diversity Biology of Non – Chordates

Time: 3hrs.

Max. Marks 40M

-
1. List out the general characters of Phylum ----- . CO1 L1 3 M
2. Identify and draw a neat labeled diagram of nervous system/appendages of prawn. 7 M
CO 4 L3 Identification: 1 M
Diagram: 4 M
Labeling: 2 M
2. Prepare a neat mount of statocyst/ mouth parts of cockroach. 5 M
CO4 L3 Mounting: 2 M
Diagram: 1 M
Labeling: 2 M
3. Identify, draw a labeled diagram, classify and write notes on A, B, C, D and E
CO3 L2 5 X 3 = 15 M
A. Protozoa & Porifera
B. Cnidaria & Platyhelminthes
C. Nematoda & Annelida
D. Arthropoda
E. Mollusca, Echinodermata & Hemichordata
- Identification: 1 M
Diagram: ½ M
Classification: ½ M
Comments: 1 M
4. Practical Record Book CO5 L3 5 M
5. VIVA CO6 L5 5M

Total Marks :- 40M

**ADUSUMILLI GOPALAKRISHNAIAH & SUGAR CANE GROWERS SIDDHARTHA DEGREE COLLEGE
OF ARTS & SCIENCE, VUYYURU-521165, KRISHNA Dt., A.P. (AUTONOMOUS).**

NACC reaccredited at 'A' level
Autonomous –ISO 9001-2015 Certified

Title of the Paper: **Cell Biology, Genetics, Molecular Biology & Evolution**

Semester: - III

Course Code	ZOO-301	Course Delivery Method	Class Room/Blended Mode - Both
Credits	3	CIA Marks	30
No. of Lecture Hours/ Week	4	Semester End Exam Marks	70
Total Number of Lecture Hours	60	Total Marks	100
Year of Introduction : 2017-18	Year of Offering 2021-2022	Year of Revision – 2021-22	Percentage of Revision: 0%

Course Outcomes:

The overall course outcome is that the student shall develop deeper understanding of what life is and how it functions at cellular level. This course will provide students with a deep knowledge in Cell Biology, Animal Biotechnology and Evolution and by the completion of the course the graduate shall be able to–

- CO1 To understand the basic unit of the living organisms and to differentiate the organisms by their cell structure.
- CO2 Describe fine structure and function of plasma membrane and different cell organelles of eukaryotic cell.
- CO3 To understand the history of origin of branch of genetics, gain knowledge on heredity, interaction of genes, various types of inheritance patterns existing in animals
- CO4 Acquiring in-depth knowledge on various aspects of genetics involved in sex determination, human karyotyping and mutations of chromosomes resulting in various disorders
- CO5 Understand the central dogma of molecular biology and flow of genetic information from DNA to proteins.
- CO6 Understand the principles and forces of evolution of life on earth, the process of evolution of new species and apply the same to develop new and advanced varieties of animals for the benefit of the society

Learning Objectives

- To understand the origin of cell and distinguish between prokaryotic and eukaryotic cell
- To understand the role of different cell organelles in maintenance of life activities
- To provide the history and basic concepts of heredity, variations and gene interaction
- To enable the students distinguish between polygenic, sex-linked, and multiple allelic modes of inheritance.
- To acquaint student with basic concepts of molecular biology as to how characters are expressed with coordinated functioning of replication, transcription and translation in all living beings
- To provide knowledge on origin of life, theories and forces of evolution
- To understand the role of variations and mutations in evolution of organisms

Syllabus
Course Details

Unit	Learning Units	Lecture Hours
I	<p>Unit-I Cell Biology Definition, history, prokaryotic and eukaryotic cells, virus, viroids, mycoplasma Electron microscopic structure of animal cell. Plasma membrane – Models and transport functions of plasma membrane. Structure and functions of Golgi complex, Endoplasmic Reticulum and Lysosomes Structure and functions of Ribosomes, Mitochondria, Nucleus, Chromosomes (Note: 1. General pattern of study of each cell organelle – Discovery, Occurrence, Number, Origin Structure and Functions with suitable diagrams) 2. Need not study cellular respiration under mitochondrial functions)</p>	10
II	<p>Unit-II Genetics –I Mendel's work on transmission of traits Gene Interaction – Incomplete Dominance, Codominance, Lethal Genes Polygenes (General Characteristics & examples); Multiple Alleles (General Characteristics and Blood group inheritance Sex determination (Chromosomal, Genic Balance, Hormonal, Environmental and Haplo-diploidy types of sex determination) Sex linked inheritance (X-linked, Y-linked & XY-linked inheritance)</p>	13
III	<p>Unit-III Genetics –II Mutations & Mutagenesis Chromosomal Disorders (Autosomal and Allosomal) Human Genetics – Karyotyping, Pedigree Analysis (basics) Basics on Genomics and Proteomics</p>	10
IV	<p>UNIT IV: Molecular Biology Central Dogma of Molecular Biology Basic concepts of – a. DNA replication – Overview (Semi-conservative mechanism, Semi-discontinuous mode, Origin & Propagation of replication fork) b. Transcription in prokaryotes – Initiation, Elongation and Termination, Post-transcriptional modifications (basics) c. Translation – Initiation, Elongation and Termination Gene Expression in prokaryotes (Lac Operon); Gene Expression in eukaryotes</p>	15
V	<p>Unit-V Origin of life Theories of Evolution: Lamarckism, Darwinism, Germ Plasm Theory, Mutation Theory. Neo-Darwinism: Modern Synthetic Theory of Evolution, Hardy-Weinberg Equilibrium. Forces of Evolution: Isolating mechanisms, Genetic Drift, Natural Selection, and Speciation.</p>	12

**A.G. &S.G.Siddhartha Degree College of Arts & Science, Vuyyuru – 521165, Krishna
Dt. A.P. (Autonomous)**

Semester III w.e.f. 2021-2022

(Model question paper)

Title of the paper: Cell Biology, Genetics, Molecular Biology & Evolution

Code – ZOO-301C

Time: 3hrs.

max.marks: 70

Section – A

4 x 5= 20.

Answer any **four** questions. Each question carries **five** marks. Draw neat labeled diagrams wherever necessary.

1. Golgicomplex
2. Nucleus,
3. LethalGenes
4. Sexdetermination
5. Mutations
6. Proteomics
7. Semi-conservativemechanism
8. Hardy-WeinbergEquilibrium

Section – B 5 x 10 =50.

Answer any **five** questions. Each question carries **Ten** marks. Draw neat labeled diagrams wherever necessary.

9. Explain the Models and transport functions of Plasmamembrane?
10. Structure and functions of Mitochondria?
11. Explain about Sex linked inheritance?
12. Give an account of Chromosomal Disorders?
13. Explain about Translation?
14. Write an essay on Gene Expression in prokaryotes?
15. Explain about theory of Lamarckism & Darwinism?
16. Write an essay on Speciation?

**A.G. & S.G.Siddhartha Degree College of Arts & Science, Vuyyuru – 521165,
Krishna Dt. A.P. (Autonomous)**

Semester -III

Guide

lines to the Paper Setter.

W.e.f. 2021-

2022 Title of the paper: Cell Biology, Genetics, Molecular Biology & Evolution

Code – ZOO-301C

Time: 3hrs.

Max. Marks: 70.

1. Answer any **four** questions out of eight in Section – A. Each question carries five marks. $4 \times 5 = 20M$.

2. Answer any **five** questions out of eight in Section – B. Each question carries Ten marks. $5 \times 10 = 50M$.

	Section	UNIT-I	UNIT-II	UNIT-III	UNIT-IV	UNIT-V
5 Marks Questions	A	2	2	2	1	1
10 Marks Questions	B	2	1	1	2	2
Weightage		30	25	20	25	25

Note: 1. please provide the scheme of valuation for the paper.

2. Question paper should be in English medium.

REFERENCES:

1. Lodish, Berk, Zipursky, Matsudaria, Baltimore, Darnell 'Molecular Cell Biology' W.H. Freeman and company New York.
2. Cell Biology by De Robertis
3. Bruce Alberts, Molecular Biology of the Cell
4. Rastogi, Cytology
5. Varma & Aggarwal, Cell Biology
6. C.B. Pawar, Cell Biology
7. Gardner, E.J., Simmons, M.J., Snustad, D.P. (2008). Principles of Genetics. VIII Edition. Wiley India.
8. Snustad, D.P., Simmons, M.J. (2009). Principles of Genetics. V Edition. John Wiley and Sons Inc.
9. Klug, W.S., Cummings, M.R., Spencer, C.A. (2012). Concepts of Genetics. X Edition. Benjamin Cummings.
10. Russell, P. J. (2009). Genetics- A Molecular Approach. III Edition. Benjamin Cummings.
11. Griffiths, A.J.F., Wessler, S.R., Lewontin, R.C. and Carroll, S.B. Introduction to Genetic Analysis. IX Edition. W. H. Freeman and Co.
12. Ridley, M. (2004). Evolution. III Edition. Blackwell Publishing
13. Molecular Biology by Freifelder
14. Instant Notes in Molecular Biology by Bios scientific publishers and Viva Books Private Limited
15. Hall, B. K. and Hallgrímsson, B. (2008). Evolution. IV Edition. Jones and Bartlett Publishers
16. Campbell, N. A. and Reece J. B. (2011). Biology. IX Edition, Pearson, Benjamin, Cummings.
17. Douglas, J. Futuyma (1997). Evolutionary Biology. Sinauer Associates.
18. Minkoff, E. (1983). Evolutionary Biology. Addison-Wesley.
19. James D. Watson, Nancy H. Hopkins 'Molecular Biology of the Gene'
20. Jan M. Savage. Evolution, 2nd ed., Oxford and IBH Publishing Co., New Delhi.
21. Gupta P.K., 'Genetics

PRACTICAL – III

Code: ZOO- 301P

w.e.f. 2021-2022

MAX.MARKS: 50.

(2hrs/week)

**Cell Biology, Genetics, Molecular Biology & Evolution
PRACTICAL SYLLABUS**

Learning Objectives:

- Acquainting and skill enhancement in the usage of laboratory microscope
- Hands-on experience of different phases of cell division by experimentation
- Develop skills on human karyotyping and identification of chromosomal disorders
- To apply the basic concept of inheritance for applied research
- To get familiar with phylogeny and geological history of origin & evolution of animals

Syllabus

Course Details

Unit	Learning Units
I	I. Cell Biology 1. Preparation of temporary slides of Mitotic divisions with onion root tips 2. Observation of various stages of Mitosis and Meiosis with prepared slides 3. Mounting of salivary gland chromosomes of <i>Chironomus</i>
II	II. Genetics 1. Study of Mendelian inheritance using suitable examples and problems 2. Problems on blood group inheritance and sex linked inheritance 3. Study of human karyotypes (Down's syndrome, Edwards syndrome, Patau syndrome, Turner's syndrome and Klinefelter syndrome)
III	III. Evolution 1. Study of fossil evidences 2. Study of homology and analogy from suitable specimens and pictures 3. Phylogeny of horse with pictures 4. Study of Genetic Drift by using examples of Darwin's finches (pictures) 5. Visit to Natural History Museum and submission of report

**A. G & S. G. S. DEGREE COLLEGE OF ARTS & SCIENCE, VUYURU 521165, KRISHNA Dt.,
A.P. (AUTONOMOUS)
PAPER – III
(Cell Biology, Genetics, Molecular Biology & Evolution)**

w.e.f.2021-22.

Model Question paper (External)Max.Marks: 25 M.

Paper Code: ZOO-301P

I. Cell Biology

1. Identify, draw neat labeled diagram & notes of the following stages. 2x2 ½= 5M.
A & B

II. Genetics

- 1.Genetics Problem. 5M.
2. Identify the following Chromosomes & Comment. 2x2 ½= 5M.
A & B

III. Evolution

1. Identify the given pictures and write the Comment. 2x2 ½= 5M
A & B
2. Identify the given pictures and Comment. 2x2 ½= 5M
A & B

**A. G.& S.G. SIDDHARTHA DEGREE COLLEGE OF ARTS & SCIENCE, VUYURU-521165
ZOOLOGY PRACTICAL -III**

**(INTERNAL)
w.e.f. 2021-2022.**

(2hrs/week).

**Cell Biology, Genetics, Molecular Biology & Evolution
Code: ZOO-301P.**

Max.marks:25M.

Time: 3hrs.

1. Attendance ----- 5M.
2. Record ----- 10M.
3. Field trip & Field note book -----10M.

Total ----- 25M.

A. G & S. G. S. DEGREE COLLEGE OF ARTS & SCIENCE, VUYYURU 521165, KRISHNA Dt., A.P.
(AUTONOMOUS)
PAPER – III

Guide lines for the practical Examiner

W.e.f.2021-2022

Class: II B.Z.C

Paper Title: **(Cell Biology, Genetics, Molecular Biology & Evolution)**

Paper Code: ZOO-301P

Max.Marks: 25 M.

.....

I.Cytology

1. Slide A from Mitosis & Slide B Meiosis. $2 \times 2 \frac{1}{2} = 5M.$
($\frac{1}{2}$ mark for identification, 1 mark for labeled diagram & 1 mark for comments)

II.Genetics

2. Checker board 2M.
Explanation 3M.
3. Identify & Comment on A& B (From Chromosomes). $2 \times 2 \frac{1}{2} = 5M$
A-Identification – 1 M, Comment – $1 \frac{1}{2} M$
B-Identification – 1 M, Comment – $1 \frac{1}{2} M$

III.Evolution

4. Identify & Comment on A& B(A- fossil evidence, B – Homology & Analogy) $2 \times 2 \frac{1}{2} = 5M$
A-Identification – 1 M, Comment – $1 \frac{1}{2} M$
B-Identification – 1 M, Comment – $1 \frac{1}{2} M$
5. Identify & Comment on A& B (A- Phylogeny of Horse, B – Darwin's Finches) $2 \times 2 \frac{1}{2} = 5M$
A-Identification – 1 M, Comment – $1 \frac{1}{2} M$
B-Identification – 1 M, Comment – $1 \frac{1}{2} M$

**ADUSUMILLI GOPALAKRISHNAIAH & SUGAR CANE GROWERS SIDDHARTHA DEGREE COLLEGE
OF ARTS & SCIENCE, VUYYURU-521165, KRISHNA Dt., A.P. (AUTONOMOUS).**

NACC reaccredited at 'A' level
Autonomous –ISO 9001-2015 Certified

Title of the Paper: Animal Biotechnology

Semester: - V

Course Code	ZOO-501	Course Delivery Method	Class Room/Blended Mode - Both
Credits	3	CIA Marks	30
No. of Lecture Hours/ Week	4	Semester End Exam Marks	70
Total Number of Lecture Hours	60	Total Marks	100
Year of Introduction : 2017-18	Year of Offering 2021-2022	Year of Revision – 2021-22	Percentage of Revision: 0%

Objective of the course: To educate students on various biotechnological techniques involve in animal biotechnology, gene manipulations, their role in production of medicines and transgenic animals.

Course outcomes:

CO1 Students are made to become aware of the use of technology that is involved in cloning.

CO2 Improved quality of species with gene manipulations

CO3 Recent development in biotechnology that helps for better environment and
Production of various monoclonal antibodies and vaccines.

CO4 Formation of different species - transgenic animals

CO5 Resistant variety and better yield

Learning Objectives

- To understand the natural function of Restriction enzymes and explained how they are used in r-DNA technology.
- To understand the features & Types of cloning vectors.
- Purposes and applications of r-DNA techniques.
- To understand uses of DNA probes.
To understand gene transfer technologies for animals and animal cell lines.
- Explain how the creation of sticky ends by restriction enzymes in use full in producing a r-DNA technologies.
- To understand the process of nucleic acid hybridization .

Syllabus
Course Details

Unit	Learning Units	Lecture Hours
I	<p>Unit 1: Tools of Recombinant DNA technology - Enzymes and Vectors Restriction modification systems : Types I, II and III- Nomenclature, Applications of Type II restriction enzymes in genetic engineering ,DNA polymerases, transferase, kinases and phosphatases,and DNA ligases Cloning Vectors: : Properties of Cloning Vectors Plasmid vectors:pBR and pUC 18, Bacteriophage and, Cosmids.Artificial Chromosome Vectors: BACs, YACs</p>	15
II	<p>Unit 2: Techniques of Recombinant DNA technology Cloning: Procedure of gene cloning, Use of linkers and adaptors. Microinjection, electroporation, biolistic method (gene gun). PCR:- Basics of PCR, Principle and Procedure of PCR. DNA Sequencing: Sanger’s method of DNA sequencing- traditional and automated sequencing. Southern, Northern and Western blotting. DNA finger printing,</p>	15
III	<p>UNIT 3 Animal Cell Technology Cell culture media: Natural and Synthetic, Types Cell cultures-: primary culture, secondary culture. Continuous cell lines , Established Cell lines (common examples such as MRC, HeLa,CHO, BHK,) Cryopreservation of cultures, Hybridoma Technology:- Cell fusion, Production of Monoclonal antibodies (mAb), Applications of mAb Stem cells: Types of stem cells- Embryonic and Adult Stem Cells, Diabetes and Parkinson’s diseases.</p>	10
IV	<p>Unit 4: Reproductive Technologies & Transgenic Animals Manipulation of reproduction in animals, Artificial Insemination, <i>In vitro</i> fertilization. Super ovulation, Embryo transfer, Embryo cloning. Transgenic Animals- Production of Transgenic Animals- sheep, fish.</p>	10
V	<p>Unit 5: Applied Biotechnology Industry: Fermentation- Different types of Fermentation. Submerged & Solid state, batch, Fed batch & Continuous (Short notes only) Downstream processing - Filtration, centrifugation, chromatography, spray drying , Fisheries: Polyploidy in fishes.</p>	10

SEMESTER-V (Model Question paper)

w.e.f.- 2021-2022. *Paper*

Title:Animal Biotechnology.

Paper Code: ZOO 501C

Time: 3 hrs.

Max.Marks:70

.....
Part – A

Answer **any FOUR** questions out of eight in Part - A. Each question carries five marks. **4 X 5 = 20**

Part – B

- 1.Ligases
- 2.YAC
- 3.Southern Blotting
- 4.DNA Fingerprinting
- 5.Applications of mAb
- 6.Polyploidy in fishes
- 7.Invivo fertilization
- 8.Chromatography

Part – B

Answer **any FIVE** questions out of eight in Part - B .Each question carries Ten marks. **5 X 10 = 50**

9. Write an essay on cloning vectors.
10. Explain the role of Type II Restriction enzymes in genetic engineering.
11. Define gene cloning .Describe the procedure of gene cloning in detail.
12. What is PCR. Briefly describe various steps of PCR.
13. Define Stem Cell Technology ? Briefly describe about it.
14. Write in detail about the transgenic animals.
15. Write an essay on different types of fermentation.
16. Briefly describe the technology of super ovulation and Embryo transfer in cattle's and discuss their applications and limitations.

SEMESTER-V

Time: 3 hrs

Max.Marks:70

Guide lines to the paper setter

Paper Title: Animal Biotechnology

Paper Code: ZOO -501C

Note:1. Answer **any FOUR** questions out of eight in Part-A . Each question carries five marks. $4 \times 5 = 20M$.

2. Answer any **FIVE** questions out of eight in Part-B . Each question carries 10 marks. $5 \times 10 = 50M$.

	PART	Unit – I	Unit – II	Unit – III	Unit – IV	Unit – V
5 Marks Questions	A	2	2	1	1	2
10 Marks Questions	B	2	2	1	2	1
Weightage		30	30	15	25	20

- Note:**
1. please provide the scheme of valuation for the paper.
 2. Question paper should be both in English and Telugu media.

Reference Books:-

1. Brown TA. (2010). Gene Cloning and DNA Analysis. 6th edition. Blackwell Publishing , Oxford,U.K
2. Clark DP and Pazdernik NJ. (2009). Biotechnology: Applying the Genetic Revolution. ElsevierAcademic Press, USA
3. Primrose SB and Twyman RM. (2006). Principles of Gene Manipulation and Genomics, 7th edition. Blackwell Publishing, Oxford, U.K.

A. G & S. G. S. DEGREE COLLEGE OF ARTS & SCIENCE, VUYYURU 521165, KRISHNA Dt., A.P.
(AUTONOMOUS)

ZOOLOGY PRACTICAL SYLLABUS

PAPER - V

Periods: 30 Code: ZOO-501P

Credits :2 Paper Title : Animal Biotechnology

Max.Marks:50

Unit	Learning Units
SYLLABUS	1. Genomic DNA isolation from <i>E. coli</i> .
	2. Plasmid DNA isolation (pUC 18/19) from <i>E. coli</i>
	3. Study the following techniques through photographs. a. Southern blotting. b. Western blotting. c. DNA sequencing (Sanger's method) d. DNA finger printing
	4. PCR (demonstration) on site or of site demonstration
	5. Project report on animal cell culture

A.G & S. G.S.DEGREE COLLEGE OF ARTS & SCIENCE, VUYYURU - 521165, KRISHNA Dt., A.P.
(AUTONOMOUS)

Practical - V *w.e.f. 2021- 22*
(Animal Biotechnology) *Max. Marks: 25*
Model Question Paper (External) *Paper Code: ZOO-501P*

-
1. Identify the following Genomic DNA isolation from *E. coli*. 5m
 2. Identify the following Plasmid DNA isolation (pUC 18/19) from *E. coli*. 5m
 3. Study the following techniques given on photographs & Write notes on 2x5=10
A & B
 4. PCR (demonstration) on site or of site demonstration. 5m
- Total: 25m

Guide lines for the Practical Examiners.

Class: III B.Z.C

Paper Title: Animal Biotechnology.

Max.Marks: 25 M.

W.e.f.2021-22.

Paper Code: ZOO-501C

-
1. Identify the following Genomic DNA isolation from *E. coli*.
(5 marks for Procedure)
 2. Identify the following Plasmid DNA isolation (pUC 18/19) from *E. coli* .
(5 marks for Procedure)
 3. Study the following techniques given on photographs & Write notes on A & B.
(1 mark for identification & 4 marks for diagram and notes, for each photographs)
 4. PCR (demonstration) on site or of site demonstration.
(5 marks for PCR demonstration)

A.G & S. G.S.DEGREE COLLEGE OF ARTS & SCIENCE, VUYURU - 521165, KRISHNA Dt., A.P.
(AUTONOMOUS)

Practical – V
(Animal Biotechnology)
Model Question Paper (Internal)

w.e.f. 2021-22
Max. Marks: 25
Paper Code: ZOO-501P

1. Attendance	--	5 M
2. Record	--	10M
3. Field trip & Field note book	--	10M

Total -- 25M

**ADUSUMILLI GOPALAKRISHNAIAH & SUGAR CANE GROWERS SIDDHARTHA DEGREE COLLEGE
OF ARTS & SCIENCE, VUYYURU-521165, KRISHNA Dt., A.P. (AUTONOMOUS).**

NACC reaccredited at 'A' level
Autonomous –ISO 9001-2015 Certified

Title of the Paper: Animal Husbandry

Semester: - V

Course Code	ZOO-502	Course Delivery Method	Class Room/Blended Mode - Both
Credits	3	CIA Marks	30
No. of Lecture Hours/ Week	4	Semester End Exam Marks	70
Total Number of Lecture Hours	60	Total Marks	100
Year of Introduction : 2017-18	Year of Offering 2021-2022	Year of Revision – 2021-22	Percentage of Revision: 0%

Objective of the course: To help students to stand on their own legs, acquire skills in poultry and Dairy farms and to set up their own firms.

Course outcomes:

CO1; Students are given awareness about different varieties of chicks.

CO2: Students are familiarized with recent technologies those are applied to produce different species with variations which are more beneficial and income fetching.

CO3: Students with the help of self help schemes, can set up their own firms, and provide

CO4: Employability to others and to tap the resources of Government and Non governmental sectors.

CO5: They are given managerial and marketing skills as well.

Learning Objectives

- To understand production of milk, meat, egg and other animal bi – products.
- To understand delivery of necessary livestock health care through timely immunization against total diseases, proper diagnosis and rational treatment for optimization of livestock production.
- To understand fulfil the objective of protein enriched quality food requirement of the growing population of the country and prevent malnutrition in one the highest malnourished children population in the world.
- To understand principles of feeding and nutrient requirements for different stages of layers and broilers.
- To make available quality concentrated animals feed to the cattle, buffalo, sheep and poultry to provide balanced ration at affordable prices.

Syllabus

Course details

Unit	Learning Units	Lecture Hours
I	UNIT – I: General introduction to poultry farming, Principles of poultry housing. Poultryhouses. Systems of poultry farming. Management of chicks, growers, layers, and Broilers.	10
II	UNIT – II: Poultry feed management – Principles of feeding. Nutrient requirements for different stages of layers and broilers. Methods of feeding- Whole grain feeding system, Grain and mash method, All mash method, Pellet feeding. Poultry diseases – viral, bacterial, fungal and parasitic (two each); symptoms, control and management.	10
III	UNIT – III: Selection, care and handling of hatching eggs, Egg testing. Methods of hatching. Brooding and rearing, Sexing of chicks.	10
IV	UNIT- IV: Breeds of Dairy Cattle and Buffaloes – Definition of breed; Classification of Indian Cattle breeds, exotic breeds and Indian buffalo breeds. Systems of inbreeding and crossbreeding. Housing of dairy animals – Selection of site for dairy farm; systems of housing – loose, housing system. Conventional dairy barn.	20
V	UNIT - V: Care and management of dairy animals - Care and management of calf, heifer, milk animal, dry and pregnant animal, bulls and bullocks. Cleaning and sanitation of programme. Records to be maintained in a dairy farm.	10

SEMESTER-V (Model Question paper)

Time: 3 hrs Paper Code: Zoo-502C

Paper Title: Animal Husbandry Max.Marks:70

Part – A

Answer **any FOUR** questions out of eight in Part - A . Each question carries five marks. **4 X 5 = 20**

1. Principles of poultry farming.
2. Chick management.
3. Poultry feed management.
4. Marek's disease.
5. Egg testing (Candle test)
6. Cleaning and sanitation of Dairy farm.
7. Milk record register
8. Loose housing system

Part – B

Answer **any five** questions out of eight in Part - B .Each question carries Ten marks. **5 X 10 = 50**

9. Write an essay on systems of poultry farming
10. Write an essay on management of Broilers
11. Write an essay on symptoms control and management of two viral and bacterial diseases.
12. Write an essay on methods of feeding in Poultry
13. Write an essay on different methods of hatching eggs
14. Give an account of breeds of Indian Cows
15. Explain the vaccination programme in Cattle
16. Write an essay on care and management of Calf, heifer and milk animals

SEMESTER-V

Time: 3 hrs

Max.Marks:70

Guide lines to the paper setter

Paper Title: Animal Husbandry.

Paper Code: 502C

Note: 1. Answer **any FOUR** questions out of eight in Part-A . Each question carries five marks. 4 X 5 = 20M.

2. Answer any **five** questions out of eight in Part-B . Each question carries 10 marks. 5 X 10 = 50M.

	PART	Unit – I	Unit – II	Unit – III	Unit – IV	Unit – V
5 Marks Questions	A	2	2	1	2	1
10 Marks Questions	B	2	2	1	2	1
Weightage		30	30	15	30	15

Note: 1. please provide the scheme of valuation for the paper.

2. Question paper should be both in English and Telugu media.

Text Books:-

1. Animal Husbandry: ---- Technical Test paper.
2. Poultry- Technical Revised Common Core.
3. Animal Husbandry --- Dr.K.Kondaiah, A.V.N.Gupta.

ZOOLOGY PRACTICAL SYLLABUS

Period: 30

PAPER – VI

Credits:2

Paper Code: Zoo-502P

Paper Title: Animal Husbandry

Max.Marks:50

Unit	Learning Units
SYLLABUS	1. Study of various breeds of layers and broilers (photographs)
	2. Identification of disease causing organisms in poultry birds (as per theory)
	3. Study of the anatomy of a poultry bird by way of dissecting a bird. (Demonstration)
	4. Study of various activities in a poultry farm (layers and broilers) and submission of a report.
	5. Study of various breeds of cattle (photographs/microfilms)
	6. Study of various activities carried out in a dairy farm and submission of a report.

A.G & S. G.S.DEGREE COLLEGE OF ARTS & SCIENCE, VUYURU - 521165, KRISHNA Dt., A.P.
(AUTONOMOUS)

Practical - VI

(Animal Husbandry)

Max. Marks: 50

Model Question Paper (External)

Paper Code: ZOO-502P

1. Study of various breeds of layers and broilers (photographs) A & B	2X2 ¹ / ₂ =5M
2. Identification of disease causing organisms in poultry birds (as per theory) A & B	2X2 ¹ / ₂ =5M
3. Study of the anatomy of a poultry bird by way of dissecting a bird. (Demonstration)	5M
4. Study of various breeds of cattle (photographs/microfilms) A & B	2X5=10M
	Total -- 25M

**A.G & S. G.S.DEGREE COLLEGE OF ARTS & SCIENCE, VUYURU - 521165, KRISHNA Dt., A.P.
(AUTONOMOUS)**

Guide lines for the Practical Examiners.

Class: III B.Z.C

Paper Title: (Animal Husbandry)

Max.Marks: 25m
Paper Code: ZOO-502C

1. Identify and comment on A & B (Charts / Photographs).
(Identification - $\frac{1}{2}$ mark & Comments -2m)
2. Identify and comment on A & B (Charts / Photographs)
(Identification - $\frac{1}{2}$ mark & Comments -2m)
3. Demonstration: (4 marks for diagram & 1 mark for labeling)
4. Identify and comment on A & B (Photographs/ microfilms).
(Identification -1 mark & Comments -4m)

A.G& S. G.S.DEGREE COLLEGE OF ARTS & SCIENCE, VUYURU - 521165, KRISHNA Dt., A.P. (AUTONOMOUS)

Animal Husbandry

Practical - V I
Max. Marks: 50

Model Question Paper (Internal) Paper Code: ZOO-502P

1. Attendance	--	5 M
2. Record	--	10M
3. Field trip & Field note book (Any one)	--	10M

Total -- 25M

**ADUSUMILLI GOPALAKRISHNAIAH & SUGAR CANE GROWERS SIDDHARTHA DEGREE COLLEGE
OF ARTS & SCIENCE, VUYYURU-521165, KRISHNA Dt., A.P. (AUTONOMOUS).**

NACC reaccredited at 'A' level
Autonomous –ISO 9001-2015 Certified

Title of the Paper: **Environmental Studies.**

Semester: - I

Course Code		Course Delivery Method	Class Room/Blended Mode - Both
Credits	2	CIA Marks	10
No. of Lecture Hours/ Week	10	Semester End Exam Marks	40
Total Number of Lecture Hours	30	Total Marks	50
Year of Introduction : 2021	Year of Offering 2020-2021	Year of Revision – 2021-22	Percentage of Revision: 0%

LIFE SKIL COURSE	CLAC001	2021-2022	B.A., B.Com., A.B.C.,&B.Sc
-------------------------	----------------	------------------	---------------------------------------

CO1: Realize the importance of environment, the goods and services of a healthy biodiversity, dependence of humans on environment.

CO2: Evaluate the ways and ill effects of destruction of environment, population explosion on ecosystems and global problems consequent to anthropogenic activities.

CO3: Discuss the laws/ acts made by government for environmental conservation and acquaint with international agreements and national movements and realize citizen's role in protecting environment and nature.

Syllabus
Course Details

Unit	Learning Units	Lecture Hours
I	<p>Unit 1: Environment and Natural Resources Multidisciplinary nature of environmental education. Scope and importance of environmental education. A brief account of forest, water and renewable energy resources. Biodiversity introduction, Levels of Biodiversity: genetic, species and ecosystem diversity. Concept, Structure and functions of an Ecosystem.</p>	8
II	<p>Unit 2 : Environmental degradation and Impacts Threats to Biodiversity: Natural calamities, habitat destruction and fragmentation, over exploitation, hunting and poaching, introduction of exotic species, pollution, predator and pest control. A brief account of causes and effects of Air, Water, Soil and Noise pollution. Non-renewable energy resources, their utilization and influences. Climate change, Global warming, Acid rains, Ozone depletion. Human population growth and its impacts on environment; land use change, land degradation, soil erosion and desertification.</p>	12
III	<p>Unit 3: Conservation of Environment Conservation of biodiversity: In-situ and ex-situ conservation of biodiversity. Control measures for various types of pollution; use of renewable and alternate sources of energy. Solid waste management- Measures for safe urban and Industrial wastes disposal. Environment Laws: Environment Protection Act; Wildlife Protection Act; Forest Conservation Act. International agreements: Montreal and Kyoto protocols. Environmental movements: Bishnois of Rajasthan, Chipko, Silent valley.</p>	10

Suggested activities to learner:

1. Visit to a local polluted site-Urban/Rural/Industrial/Agricultural site.
2. Visit to a local waste disposal/ land filling site

Reference Books :

1. Environmental Studies by Dr.M.Satyanarayana, Dr.M.V.R.K.Narasimhacharyulu, Dr.G. Rambabu and Dr.V.VivekaVardhani, Published by Telugu Academy, Hyderabad.
2. Environmental Studies by R.C.Sharma, Gurbir Sangha, published by Kalyani Publishers.
3. Environmental Studies by Purnima Smarath, published by Kalyani Publishers

MODEL PAPER
AEC002 /HRDMM/

Title of the paper: Environmental Studies.

No. of Pages:-1.

Max. Marks: 40M

Time: 2 Hrs

No. of Questions: 16 Pass min. 16M

SECTION –A

Answer any FOUR of the following:

4x7=28 M

1. Explain the scope and importance of environmental studies?
.
2. Give an account of renewable energy resources?
.
3. Define ecosystem. Explain the structural components of an ecosystem?
.
4. Define biodiversity. Explain various strategies for its conservation?
.
5. Explain the causes, effects and control measures of air pollution?
.
6. Give an account on environmental acts?

SECTION –B

Answer any SIX of the following:

6x2=12 M

7. Deforestation.
8. Chipko movement
9. Food chain
10. Biodiversity Hotspots
11. Poaching
12. Floods
13. Earthquakes
14. Rainwater harvesting
15. Global warming
16. Population explosion

**ADUSUMILLI GOPALAKRISHNAIAH & SUGAR CANE GROWERS SIDDHARTHA DEGREE COLLEGE
OF ARTS & SCIENCE, VUYYURU-521165, KRISHNA Dt., A.P. (AUTONOMOUS).**

NACC reaccredited at 'A' level
Autonomous –ISO 9001-2015 Certified

Title of the Paper: **Poultry Farming**

Semester: - III

Course Code	PF-301	Course Delivery Method	Class Room/Blended Mode - Both
Credits	2	CIA Marks	00
No. of Lecture Hours/ Week	10	Semester End Exam Marks	50
Total Number of Lecture Hours	30	Total Marks	50
Year of Introduction :	Year of Offering 2020-2021	Year of Revision – 2021-22	Percentage of Revision: 0%

SKILL DEVELOPMENT COURSE	Course code: PF-301	2021-2022	A.B.C.,& B.Sc
---------------------------------	------------------------	------------------	--------------------------

Learning Outcomes:

By successful completion of the course, students will be able to;

1. Understand the field level structure and functioning of insurance sector and its role in protecting the risks
2. Comprehend pertaining skills and their application for promoting insurance coverage
3. Prepare better for the Insurance Agent examination conducted by IRDA
4. Plan 'promoting insurance coverage practice' as one of the career options.

Syllabus
Course Details

Unit	Learning Units	Lecture Hours
I	<p>Section I (Introduction to Poultry Farming): General introduction to poultry farming -Definition of Poultry; past and present scenario of poultry industry in India. Principles of poultry housing. Poultry houses. Systems of poultry farming. Management of chicks, growers and layers. Management of Broilers. Preparation of project report for banking and insurance</p>	10
II	<p>Section II (Feed and Livestock Health Management): Poultry feed management – Principles of feeding, Nutrient requirements for different stages of layers and broilers. Feed formulation and Methods of feeding. Poultry diseases – viral, bacterial, fungal and parasitic (two each); symptoms, control and management; Vaccination programme.</p>	10
III	<p>Section III (Harvesting of Eggs and Sanitation): Selection, care and handling of hatching eggs. Egg testing .Methods of hatching. Brooding and rearing. Sexing of chicks. Farm and Water Hygiene, Recycling of poultry waste.</p>	10

Co- Curricular Activities suggested:

(4 Hrs)

1. Group discussion & SWOT analysis
2. Visit to a poultry farm
3. Invited Lectures by Concerned officers of government or private farms
4. Cheap and Healthy Feed preparation by students based on government standards
5. Market study and Survey (Monitoring of daily price hike in poultry market and analysis)
6. Online Swayam Moocs course on poultry farming (see reference 9 below)

Reference books:

1. Sreenivasaiah., P. V., 2015. Textbook of Poultry Science. 1st Edition. Write & Print Publications, New Delhi
2. Jull A. Morley, 2007. Successful Poultry Management. 2nd Edition. Biotech Books, New Delhi"

Semester –III

w.e.f. 2021-2022 Time: 90 mins (Model question paper)

Title of the paper: Poultry Farming. Code – PF- 301(SDC)

max.marks: 50

Section – A

Answer any **four** questions. Each question carries **five** marks. $4 \times 5 = 20$.

1. Poultry house
2. Broilers
3. Any two viral diseases of poultry
4. Any two bacterial diseases of poultry
5. Any two fungal diseases of poultry
6. Egg testing
7. Brooding
8. Sexing chicks

Section – B

Answer any **three** questions. Each question carries **Ten** marks. $3 \times 10 = 30$

9. Discuss briefly the past, present and future scenario of poultry farming industry in India
10. Explain principles of poultry housing in detail, with examples.
11. Write an essay on viral diseases of poultry.
12. Give an account of fungal and bacterial diseases (any two each) of poultry
13. Write an essay on selection, handling and hatching of eggs.

A.G & S.G.S.DEGREE COLLEGE OF ARTS & SCIENCE, VUYURU 521165, KRISHNA Dt., A.P.
(AUTONOMOUS)

**SEMESTER-III
SKILL DEVELOPMENT COURSE**

Guide lines to the paper setter

Time: 1¹/₂ hrs

Max.Marks:50

Paper Title: - Poultry Farming.

Paper Code: PF-301 (SDC)

*Note:*1. Answer **any four** questions out of eight in Part-A. Each question carries five marks.4X 5 = 20M.

2. Answer any**three** questions out of five in Part-B. Each question carries 10 marks.3 X 10 = 30M.

	PART	Unit –I	Unit – II	Unit-III
5 Marks Questions	A	2	3	3
10 Marks Questions	B	2	2	1
Weightage		30	35	25

- Note:**
1. please provide the scheme of valuation for the paper.
 2. Question paper should be both in English and Telugu media.

**A.G& S.G.SIDDHARTHA DEGREE COLLEGE OF ARTS & SCIENCE
VUYYURU-521165, KRISHNA Dt., A.P. (Autonomous)**

**Accredited by NAAC with "A" Grade
2021-2022**



**DEPARTMENT OF ZOOLOGY
MINUTES OF BOARD OF STUDIES
EVEN SEMESTER
01-04-2022**







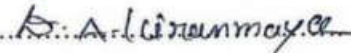

Minutes of the meeting of Board of studies in Zoology for the Autonomous courses of AG & SG Siddhartha Degree College of Arts & Science, Vuyyuru, held at 2:30 pm on 01.04,2022 in the Department of Zoology.

Smt.D.A. Kiranmayee. ...

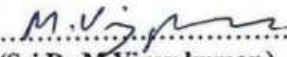
Presiding

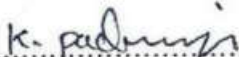
Members Present:

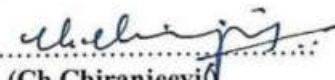
- 1)  Chair person Head, Department of Zoology,
(Smt. D.A.Kiranmayee.) A.G&S.G.S Degree College of
Vuyyuru-521165.
- 2)  University Nominee Bio Sciences & Bio technology
(Smt. Dr.L.Suseela.) Krishna University
Machilipatnam.
- 3)  Academic Council Head,Department of Zoology,
(Sri Dr.M.Viyay kumar.) Nominee SRR & CVR Govt. Degree College,
Vijayawada.
- 4)  Academic Council Head, Department of Zoology,
(Sri Ch. Venkateswaralu.) Nomine P.B. Siddhartha College,
Vijayawada.
- 5)  Member Lecturer in Zoology,
(Smt. K. Padmaja.) A.G&S.G.S Degree College
Vuyyuru-521165.
- 6)  Industrialist Asst. Project Manager,
(B. Appala Naidu.) RGCA
Manikonda.
- 7)  Student Represent P.hd -Research Scholar,
(Ch.Chiranjeevi) Dept.of Botany & Microbiology,
Acharya Nagarjuna University,
Guntur.

ZOOLOGY

Agenda for B.O.S Meeting.

1. To recommend the syllabi (Theory & Practical), Model question paper for II Semester of I B.Sc (B.Z.C) for the academic year 2021 - 2022.
2. To recommend the syllabi (Theory & Practical), Model question paper for IV Semester of II B.Sc (B.Z.C) for the academic year 2021 - 2022.
3. To discuss to the syllabus of Elective & Clusters in VI semesters to be for the academic year 2021-2022.
4. To recommend the syllabi (Theory & Practical), Model question paper for VI Semester of III B.Sc (B.Z.C) for the academic year 2021 - 2022.
5. To recommend the Blue print for the semester end exam for I, IV& VI semester of I,II,III B.Sc (B.Z.C) for the academic year 2021 - 2022.
6. To recommend the conduction of Value Added Course in Sericulture
6. To recommend the teaching and evaluation methods to be followed under Autonomous statues.
7. Any other matter.

B. A. Chinnmayee

CHAIRMAN

ZOOLOGY- RESOLUTIONS

1. It is resolved to continue the revised syllabi (Theory & Practical), model question paper & guide lines to be followed by the question paper setters of Zoology II semester of I B.Sc. (B.Z.C) under Choice Based Credit System (CBCS) to be approved by the Academic Council of 2021 – 2022. The syllabus is revised in all the units of II semester of I B.Sc. (B.Z.C) according to the suggestions of BOS members.

2. It is resolved to implement the Revised syllabi (Theory & Practical) as per the instructions of APSCHE, under Choice Based Credit System (CBCS) for Zoology IV Semester of II B.Sc. (B.Z.C) to be approved by the Academic Council of 2021 –2022. Two Papers are introduced in Sem IV with Titles Animal Physiology, Cellular metabolism and Embryology-Course Code-Zoo 401, and Immunology and Animal Bio-Technology Course-code Zoo-402

3. It is resolved to follow Elective – A (Immunology) in VI Semester from the Academic year 2021-2022 for IIB.Sc. BZC

4. It is resolved to continue the following teaching & evaluation methods for the Academic year 2021-22.

Teaching methods:

Besides the conventional methods of teaching, we use modern technology i.e. Using of OHP and LCD projector to display on U boards etc; for better understanding of concepts.

Evaluation of a student is done by the following procedure:

Internal Assessment Examination:

- Out of maximum 100 marks in each paper for II, III B.Sc, 30 marks shall be allocated for internal assessment.
- Out of these 30 marks, 20 marks are allocated for announced tests (i.e . IA-1& IA-2). Two announced tests will be conducted and average of these two tests shall be deemed as the marks obtained by the student, 5 marks are allocated on the basis of candidate's percentage of attendance and remaining 5 marks are allocated for the assignment for II, III B.SC.
- Out of maximum 100 marks in each paper for II B.Sc, 25 marks shall be allocated for internal assessment.
- Out of these 25 marks, 15 marks are allocated for announced tests (i.e . IA-1& IA-2). Two announced tests will be conducted and average of these two tests shall be deemed as the marks obtained by the student, 5 marks allocated on the basis of candidate's percentage of attendance / assignment for II semester. There is no pass minimum for internal assessment for I, II, III B.Sc

Semester – End Examination:

- The maximum mark for II (BZC) semester – End examination shall be 75 marks and duration of the examination shall be 3 hours.
- The maximum mark for II, III B.Sc semester- End examination shall be 70 marks and duration of the examination shall be 3 hours. Even though the candidate is absent for two IA exams / obtain zero marks the external marks are considered (if the candidate gets 40/70) and the result shall be declared as "PASS"
- Semester – End examination shall be conducted in theory papers at the end of every semester, while in practical papers, these examinations are conducted at the end of I, IV, & VI semester for I, II & III B.Sc.
- Discussed and recommended for organizing Seminars, Guest lectures, Work – Shops to upgrade the Knowledge of students, for the approval of the Academic Council.

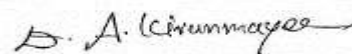

Chairman

**ADUSUMILLI GOPALAKRISHNAIAH & SUGAR CANE GROWERS SIDDHARTHA DEGREE COLLEGE
OF ARTS & SCIENCE, VUYYURU-521165, KRISHNA Dt., A.P. (AUTONOMOUS).**

NAAC reaccredited at 'A' level
Autonomous –ISO 9001-2015 Certified

Title of the Paper: **Animal Diversity Biology of Chordates.**

Semester: - II

Course Code	ZOO T21A	Course Delivery Method	Class Room/Blended Mode - Both
Credits	4	CIA Marks	25
No. of Lecture Hours/ Week	4	Semester End Exam Marks	75
Total Number of Lecture Hours	60	Total Marks	100
Year of Introduction : 2021-22	Year of Offering 2020-2021	Year of Revision – 2021-22	Percentage of Revision: 70%

Course Description:

This course will provide one with a basic and comprehensive understanding of *Pro chordates* and pisces origin, type study, respiratory, circulatory and nervous system etc., Enable the student with depth of topics and helps then to gain appreciation of Amphibia and Reptilia type studies, Aves and mammals type studies. On the other hand, importance of understanding parental care in amphibians, south indian chelonians, birds as glorified reptiles and significance of birds migration and flight adaptations in birds are learnt. A part from these the students will be enhanced with the knowledge of aquatic mammals and dentition in mammals.

Course Objectives:

- To understand the structural organization of animals of prochordates and cyclostomes.
- To understand the type study belonging to Pisces.
- To understand type study belonging to amphibian.
- To understand the type study belonging to reptilia and identification of piousness snakes.
- To understand the type study belonging to Aves and Aquatic mammals.

Course Outcomes:

CO1	Gain knowledge in the major Chordate groups, describe their salient features, appreciate the diversity and analyze the uniqueness of different groups.
CO 2	Understand the fundamental organization of chordates and evaluate the similarities and differences among the different groups of chordates in the light o evolutionary significance.
CO 3	Comprehend and compare the morphology and anatomy of different classes of chordates and apply the same to their fitness in the ecological habitats
CO 4	Develop the skill of identifying the vertebrate fauna in general and South Indian fauna in specific.
CO 5	Acquaint with the significance of unique mechanisms and behavioral patterns exhibited by different groups of chordates.

Syllabus

Unit	Learning Units	Lecture Hours
I	<p>UNIT I</p> <p>Protochordates to cyclostomes</p> <p>Protochordates</p> <p>Salient features of Urochordata and Cephalochordata 1 hour</p> <p>Structure and life-history of <i>Herdmania</i>, 2 hours</p> <p>Significance of retrogressive metamorphosis. 2 hours</p> <p>General organization of vertebrates 1 hour</p> <p>General characters of cyclostomes 1 hour</p> <p>Comparison of <i>Petromyzon</i> and <i>Myxine</i> 1 hour</p>	8 hrs
II	<p>UNIT II</p> <p>Fishes</p> <p>Type study – <i>Scoliodon</i> - Morphology, respiratory, circulatory, excretory and nervous systems and sense organs. 8hrs</p> <p>Migration in fishes. 1 hour</p> <p>Viviparity in fishes 1 hour</p> <p>Types of scales 1 hour</p> <p>Accessory respiratory organs in fishes 2 hours</p>	13 HOURS
III	<p>UNIT III</p> <p>Amphibia</p> <p>South Indian Amphibians. 1 hour</p> <p>Type study - <i>Rana</i>: Morphology, digestive system, respiratory system, circulatory system, excretory system, nervous system and reproductive system 9 hours</p> <p>Parental care in amphibians 1 hour</p>	11 HOURS
IV	<p>UNIT IV</p> <p>Reptilia</p> <p>South Indian Chelonians. 2 hours</p> <p>Type study – <i>Calotes</i>: Morphology, digestive, respiratory, circulatory, urinogenital and nervous systems. 8hrs</p> <p>Identification of poisonous snakes 1 hour</p>	11 HOURS
V	<p>UNIT V</p> <p>Aves and Mammalia</p> <p>Aves</p> <p>Birds as Glorified Reptiles. 2 hours</p> <p>Type study - Pigeon (<i>Columba livia</i>): Exoskeleton, respiratory, circulatory and excretory systems 7 hours</p> <p>Significance of migration in birds 2 hours</p> <p>Flight adaptations in birds 2 hours</p> <p>Mammalia</p> <p>Aquatic Mammals 2 hours</p> <p>Dentition in Mammals. 2 hours</p>	17 HOURS

Textbooks

1. R.L. Kotpal, *Modern Text Book of Zoology - Invertebrates*.
2. P.S. Dhama and J.K. Dhama *Invertebrate Zoology*.

Suggested Readings

1. E.L. Jordan and P.S. Verma '*Chordate Zoology*' - S. Chand Publications.
2. Mohan P. Arora. '*Chordata – I*, Himalaya Publishing House Pvt. Ltd.
3. Marshall, Parker and Haswell '*Text book of Vertebrates*'. ELBS and McMillan, England.
4. Alfred Sherwood Romer. Thomas S. Pearson '*The Vertebrate Body*, Sixth edition, CBS college Publishing, Saunders College Publishing

Course Delivery method: Face-to-face / Blended.

Course has focused on: Foundation

Websites of Interest:

https://www.youtube.com/watch?v=-mcfPHd_sH8

<https://www.youtube.com/watch?v=U8F9IzuwdzQ><https://www.youtube.com/watch?v=jhXqIy49YEw>

<https://www.youtube.com/watch?v=ywD50XyayFk>

Co-curricular Activities:

- Preparation of charts on Chordate classification (with representative animal photos) and retrogressive metamorphosis
- Thermocol or Clay models of Herdmania and Amphioxus.
- Visit to local fish market and identification of local cartilaginous and bony fishes.
- Maintaining of aquarium by students.
- Thermocol model of fish heart and brain.
- Preparation of slides of scales of fishes.

A.G. &S.G.Siddhartha Degree College of Arts & Science, Vuyuru – 521165, Krishna Dt. A.P. (Autonomous)

Semester II

(Model question paper)

Title of the paper:- ANIMAL DIVERSITY - BIOLOGY OF CHORDATES

Course Code: ZOO T21A

Time: 3 Hrs

Max. Marks: 75M

Draw neat labeled diagrams wherever necessary.

SECTION-A

Answer any Five of the following.

5X5= 25M

1. Describe the structure of *Herdmania*– CO1 L2
2. Enumerate the general characters of Cephalochordata – CO1 L1
3. Explain the different types of Scales in fishes –CO2 L2
4. Enumerate the different South Indian Amphibians – CO3, L4
5. Describe the Female Genital System in *Calotes*– CO4, L2
6. Describe the structure of a Quill feather – CO5, L1
7. Explain and Illustrate the structure of Tooth – CO5, L3
8. Give an account of the lateral line system in *Scoliodon*- CO2, L2

SECTION-B

Answer the following Questions.

5X10=50M

9. (a). What is meant by Retrogressive Metamorphosis? Apply the phenomenon with reference to the development of *Herdmania* – CO1, L3

(Or)

(b). Enumerate the General characters of Cyclostomes – CO1 L3

10. (a). Describe the Respiratory system in *Scoliodon*– CO2, L2

(Or)

(b) Explain the significance of Accessory respiratory organs –CO3, L2

11.(a) Describe Respiratory system in *Rana*– CO3, L2

(Or)

(b). Discuss Parental Care in Amphibians – CO3 L2

12.(a). Explain about the South Indian Chelonians – CO4, L2

(Or)

(b). Describe the Arterial System in *Calotes*- CO4, L2

13.(a) Describe the Respiratory system in Penguin – CO,5 L2

(Or)

(b). Explain about the Aquatic Mammals – CO5, L2

PRACTICAL - II

w.e.f. 2021-2022.

Code: ZOO T21A

Title of the paper: - Animal Diversity Biology of Chordates.

MAX.MARKS: 50.

(2hrs/week)

Course Prerequisites:

Knowledge of vertebrates acquired in Intermediate

Course Description:

This course will provide one with a basic and comprehensive understanding of *Pro chordates* and pices origin, type study, respiratory, circulatory and nervous system etc., Enable the student with depth of topics and helps then to gain appreciation of Amphibia and reptalia type studies, Aves and mammals type studies. On the other hand, importance of understanding parental care in amphibians, south indian chelonians, birds as glorified reptailles and significance of bird's migration and flight adaptations in birds are learnt. A part from these the students will be enhanced with the knowledge of aquatic mammals and dentition in mammals.

LEARNING OUTCOMES:

By the end of the course students will be able to

1. to Understand the general characters and classification from Pisces to Mammalia
2. to Understand the importance of preservation of museum specimens
3. to Identify chordates based on special identifying characters
4. to Understand different organ systems through demo or virtual dissections

COURSE OUTCOMES:

CO1	To identify the systematic position of Protochordata, Cyclostomata and Pisces.
CO2	To identify the systematic position of Amphibians and Reptiles.
CO3	To identify the systematic position of Aves and mammals.
CO4	To Study the Appendicular skeleton of <i>Varanus</i> , <i>Gallus</i> and <i>Oryctolagus</i> .
CO5	To understand the various systems of Fish by Dissecting and process of Mounting

SYLLABUS:

General characters and classification of the following phyla and sub-phyla up to classes with suitable examples: Pisces (up to subclass only), Amphibia (up to orders), Reptilia (up to orders) Aves (up to subclass only) and Mammalia (up to infraclass only).

I. SPECIMENS.

1. Protochordata: Herdmania, Amphioxus.

Slides: Amphioxus T.S through pharynx.

2. Cyclostomata: Petromyzon, Myxine.

3. Pisces: Pristis, Torpedo, Channa, Pleuronectes, Labeo, Catla, Hippocampus, Exocoetus, Echeneis, Clarias, Anguilla.

Slides: Fish scales.

4. Amphibia: Ichthyophis, Amblystoma, Siren, Axolotl larva, Hyla, Rhacophorus.

5. Reptilia: Trionyx, Testudo, Draco, Chamaeleon, Uromastix, Daboia (=Vipera russelli)

Naja, Enhydrina, Bungarus, Crocodilus.

6. Aves: Psittacula, Bubo, Alcedo, Passer, Eudynamis, Corvus

Different types of feathers- quill, contour, filoplume and down.

7. Mammalia: Ornithorhynchus, Didelphys, Pteropus, Funambulus, Manis, Erinaceus.

II. OSTEOLOGY.

Appendicular skeleton of *Varanus*, *Gallus* and *Oryctolagus* - limbs and girdles.

III. DEMONSTRATION OF DISSECTIONS

1. Mounting of fish scales.

2. *Channa*: Digestive system

3. *Scoliodon*: V, VII, IX and X cranial nerves.

Suggested Manuals:

Suggested manuals

1. Practical Zoology – Vertebrata - S.S.Lal

2. A manual of Practical Zoology – Chordata P.S.Verma

Co-curricular Activities:

Preparation of slides of scales of fishes

- Visit to local/nearby river to identify migratory fishes and prepare study notes
- Preparation of Charts on topics by students (Eg: comparative account of vertebrate heart/brain/lungs, identification of snakes etc.)

heart/brain/lungs, identification of snakes etc.)

- Collecting and preparation of Museum specimens with dead frogs/snakes/lizards etc., and/or their skeletons

**A. G & S. G. S. DEGREE COLLEGE OF ARTS & SCIENCE, VUYYURU 521165, KRISHNA Dt.,
A.P. (AUTONOMOUS)**

II B.Sc. ZOOLOGY PRACTICAL EXAMINATION

PRACTICAL- II COURSE CODE: ZOO P21A
TITLE OF THE PAPER: ANIMAL DIVERSITY - BIOLOGY OF CHORDATES
Time: 3hrs.

Max. Marks 40M

SEE MODEL PAPER

1. List out the general characters of Class Mammalia. CO5, L1 5 M

2. Identify and draw a neat labelled diagram of digestive system of *Channa*. CO2, L3 10 M
Identification: 2M
Diagram: 4 M
Labelling: 4 M

3. Identify, draw a labelled diagram, classify and write notes on A, B, C, D and E CO1,2,3,4,5 L2 5 X 3 = 15 M
A. Protochordata and Cyclostomata
B. Pisces
C. Amphibia and Reptilia
D. Aves and Mammalia
E. Osteology
Identification: 1 MP
Diagram : $\frac{1}{2}$ M
Classification: $\frac{1}{2}$ M
Comment 1 M

4. Practical Record Book CO1, 2,3,4,5 L3 5 M

5. VIVA CO1, 2,3,4,5 L5 5 M

**ADUSUMILLI GOPALAKRISHNAIAH & SUGAR CANE GROWERS SIDDHARTHA DEGREE COLLEGE
OF ARTS & SCIENCE, VUYURU-521165, KRISHNA Dt., A.P. (AUTONOMOUS).**

NAAC reaccredited at 'A' level
Autonomous –ISO 9001-2015 Certified

Title of the Paper: **ANIMAL PHYSIOLOGY, CELLULAR METABOLISM ANDEMBRYOLOGY**

Semester: - IV

Course Code	ZOO-401	Course Delivery Method	Class Room/Blended Mode - Both
Credits	3	CIA Marks	30
No. of Lecture Hours/ Week	4	Semester End Exam Marks	70
Total Number of Lecture Hours	60	Total Marks	100
Year of Introduction : 2019-20	Year of Offering 2021-2022	Year of Revision – 2021-22	Percentage of Revision: 100%

Course Outcomes:

This course will provide students with a deep knowledge in Physiology, Cellular metabolism and Molecular Biology and by the completion of the course the graduate shallable to–

CO1: Understand the functions of important animal physiological systems including digestion, cardio-respiratory and renal systems.

CO2: Understand the muscular system and the neuro-endocrine regulation of animal growth, development and metabolism with special knowledge of hormonal control of human reproduction.

CO3: Describe the structure, classification and chemistry of biomolecules and enzymes responsible for sustenance of life in living organisms

CO4: Develop broad understanding the basic metabolic activities pertaining to the catabolism and anabolism of various biomolecules

CO5 : Describe the key events in early embryonic development starting from the formation of gametes upto gastrulation and formation of primary germ layers.

Learning Objectives

- To achieve thorough understanding of various aspects of physiological systems and their functioning in animals.
- To instill the concept of hormonal regulation of physiology, metabolism and reproduction in animals.
- To understand the disorders associated with the deficiency of hormones
- To demonstrate thorough knowledge of the intersection between the disciplines of Biology and Chemistry.
- To provide insightful knowledge on the structure and classification of carbohydrates, proteins, lipids and enzymes
- To demonstrate an understanding of fundamental biochemical principles such as the function of biomolecules, metabolic pathways and the regulation of biochemical processes
- To make students gain proficiency in laboratory techniques in biochemistry and orient them to apply the scientific method to the processes of experimentation and hypothesis testing.

Syllabus
Course Details

Unit	Learning Units	Lecture Hours
I	<p>Animal Physiology -I Process of digestion and assimilation Respiration - Pulmonary ventilation, transport of oxygen and CO₂ (Note: Need not study cellular respiration here) Circulation - Structure and functioning of heart, Cardiac cycle Excretion - Structure and functions of kidney urine formation, counter current Mechanism</p>	10
II	<p>Animal Physiology –II Nerve impulse transmission - Resting membrane potential, origin and propagation of action potentials along myelinated and non-myelinated nerve fibers Muscle contraction - Ultra structure of muscle, molecular and chemical basis of muscle contraction Endocrine glands - Structure, functions of hormones of pituitary, thyroid, parathyroid, adrenal glands and pancreas Hormonal control of reproduction in a mammal</p>	15
III	<p>Cellular Metabolism –I (Biomolecules) Carbohydrates - Classification of carbohydrates. Structure of glucose Proteins - Classification of proteins. General properties of amino acids Lipids - Classification of lipids Enzymes: Classification and Mechanism of Action</p>	15
IV	<p>Cellular Metabolism –II Carbohydrate Metabolism - Glycolysis, Krebs cycle, Electron Transport Chain, Glycogen metabolism, Gluconeogenesis Lipid Metabolism – β-oxidation of palmitic acid Protein metabolism – Transamination, Deamination and Urea Cycle</p>	10
V	<p>Embryology: Gametogenesis Fertilization Types of eggs Types of cleavages Development of Frog up to formation of primary germ layers</p>	10

REFERENCEBOOKS

1. Eckert H. *Animal Physiology: Mechanisms and Adaptation*. W.H. Freeman & Company.
2. Flory E. *An Introduction to General and Comparative Animal Physiology*. W.B. Saunders Co., Philadelphia.
3. Goel KA and Satish KV. 1989. *A Text Book of Animal Physiology*, Rastogi Publications, Meerut, U.P.
4. Hoar WS. *General and Comparative Physiology*. Prentice Hall of India, New Delhi.
5. Lehninger AL, Nelson and Cox. *Principles of Biochemistry*. Lange Medical Publications, New Delhi.
6. Prosser CL and Brown FA. *Comparative Animal Physiology*. W.B. Saunders Company, Philadelphia.
7. *Developmental Biology* by Balinsky
8. *Developmental Biology* by Gerard Karp
9. *Chordate embryology* by Varma and Agarwal
10. *Embryology* by V.B. Rastogi
11. Austen CR and Short RV. 1980. *Reproduction in Mammals*. Cambridge University Press.
12. Gilbert SF. 2006. *Developmental Biology*, 8th Edition. Sinauer Associates Inc., Publishers, Sunderland, USA.
13. Longo FJ. 1987. *Fertilization*. Chapman & Hall, London.
14. Rastogi VB and Jayaraj MS. 1989. *Developmental Biology*. Kedara Nath Ram Nath Publishers, Meerut, Uttar Pradesh.
15. Schatten H and Schatten G. 1989. *Molecular Biology of Fertilization*. Academic Press, New York.

A.G. &S.G.Siddhartha Degree College of Arts & Science, Vuyyuru – 521165, Krishna Dt. A.P. (Autonomous)

Semester IV *w.e.f. 2021-2022*
(Model question paper)

Title of the paper: ANIMAL PHYSIOLOGY, CELLULAR METABOLISM AND EMBRYOLOGY

Code – ZOO-401C

Time: 3hrs.

max.marks: 70

Section – A 4 x 5 = 20.

Answer any **four** questions. Each question carries **five** marks. Draw neat labeled diagrams wherever necessary.

1. Cardiac cycle
2. Non-myelinated nerve fibers
3. pituitary gland
4. Structure of glucose
5. Glycolysis
6. Urea Cycle
7. Fertilization
8. Types of cleavages

Section – B 5 x 10 = 50.

Answer any **five** questions. Each question carries **Ten** marks. Draw neat labeled diagrams wherever necessary.

9. Give an account of process of digestion in mammals?
10. Describe the Structure and functions of Mammal heart?
11. Explain about the production of Nerve Impulse?
12. Explain about the hormonal control of reproduction in mammals?
13. Give an account of Classification of carbohydrates?
14. Discourse about General properties of amino acids?
15. Explain about Krebs cycle ?
16. Write an essay on types of eggs?

**A.G. & S.G.Siddhartha Degree College of Arts & Science, Vuyuru – 521165,
Krishna Dt. A.P. (Autonomous)
Semester -IV**

Guide lines to the Paper Setter.

W.e.f. 2021-2022

Title of the paper: ANIMAL PHYSIOLOGY, CELLULAR METABOLISM ANDEMBRYOLOGY

Code – ZOO-401C

Time: 3hrs.

Max. Marks: 70.

1. Answer any **four** questions out of eight in Section – A. Each question carries five marks. $4 \times 5 = 20M$.

2. Answer any **five** questions out of eight in Section – B. Each question carries Ten marks. $5 \times 10 = 50M$.

	Section	UNIT-I	UNIT-II	UNIT-III	UNIT-IV	UNIT-V
5 Marks Questions	A	1	2	1	2	2
10 Marks Questions	B	2	2	2	1	1
Weightage		25	30	25	20	20

Note: 1. please provide the scheme of valuation for the paper.

2. Question paper should be in English medium.

PRACTICAL - IV

w.e.f. 2021-2022.

Code: ZOO- 401P

ANIMAL PHYSIOLOGY, CELLULAR METABOLISM AND EMBRYOLOGY

MAX.MARKS: 50.

(2hrs/week)

PRACTICAL SYLLABUS

Learning Objectives:

- Identification of an organ system with histological structure
- Deducing human health based on the information of composition of blood cells
- Demonstration of enzyme activity *in vitro*
- Identification of various biomolecules of tissues by simple colorimetric methods and also quantitative methods
- Identification of different stages of early embryonic development in animals

I. ANIMAL PHYSIOLOGY

1. Qualitative tests for identification of carbohydrates, proteins and fats
2. Study of activity of salivary amylase under optimum conditions
3. T.S. of duodenum, liver, lung, kidney, spinal cord, bone and cartilage
4. Differential count of human blood

II. CELLULAR METABOLISM

1. Estimation of total proteins in given solutions by Lowry's method.
2. Estimation of total carbohydrate by Anthrone method.
3. Qualitative tests for identification of ammonia, urea and uric acid
4. Protocol for Isolation of DNA in animal cells

III. EMBRYOLOGY

1. Study of T.S. of testis, ovary of a mammal
2. Study of different stages of cleavages (2, 4, 8 cell stages)
3. Construction of fate map of frog blastula

REFERENCE BOOKS:

- Harper's Illustrated Biochemistry
- Cell and molecular biology: Concepts & experiments. VI Ed. John Wiley & sons. Inc.
- Lab Manual on Blood Analysis and Medical Diagnostics, S.Chand and Co.Ltd.
- Laboratory techniques by Plummer

**A. G & S. G. S. DEGREE COLLEGE OF ARTS & SCIENCE, VUYYURU 521165, KRISHNA Dt.,
A.P. (AUTONOMOUS)
PAPER – IV**

(Animal physiology, Cellular Metabolism and Embryology)

w.e.f.2021-22.

*Model Question paper (External)Max.Marks: 25 M.
Paper Code: ZOO-401P*

I.Embryology:

1. Identify, draw neat labeled diagram & comment on. 2x 1^{1/2} = 3M.

A & B

II. Physiology& Cellular Metabolism

2. Identify, draw neat labeled diagram & comment on .2x 1^{1/2} = 3M. **A & B**
3. Studyof activityof salivaryamylaseunder optimumconditions 4M
4. Identify the Qualitative test for in the given samples A & B, each with two tests. 4x 1^{1/2} = 6M.
(Sample A- 2X1^{1/2} =3 Marks & sample B -- 2X1 ^{1/2} =3 Marks)
5. Identify the Qualitative test for in the given samples A & B, each with two tests. 4x 1^{1/2} = 6M.
(Sample A- 2X1 ^{1/2} =3 Marks & sample B -- 2X1 ^{1/2} =3 Marks)
6. Identify, draw neat labeled diagram &comment on. 2x 1^{1/2} = 3M.

A & B

**A. G.& S.G. SIDDHARTHA DEGREE COLLEGE OF ARTS & SCIENCE, VUYYURU-521165
ZOOLOGY PRACTICAL -IV**

**(INTERNAL)
w.e.f. 2021-2022.**

(2hrs/week).

**(Animal physiology, Cellular Metabolism and Embryology)
Code: ZOO-401P.**

Max.marks:25M.

Time: 3hrs.

1. Attendance ----- 5M.
2. Record ----- 10M.
3. Assignment -----10M.

Total ----- 25M.

**ADUSUMILLI GOPALAKRISHNAIAH & SUGAR CANE GROWERS SIDDHARTHA DEGREE COLLEGE
OF ARTS & SCIENCE, VUYURU-521165, KRISHNA Dt., A.P. (AUTONOMOUS).**

NAAC recredited at 'A' level
Autonomous –ISO 9001-2015 Certified

Title of the Paper: **IMMUNOLOGY AND ANIMAL BIOTECHNOLOGY**

Semester: - IV

Course Code	ZOO-402	Course Delivery Method	Class Room/Blended Mode - Both
Credits	3	CIA Marks	30
No. of Lecture Hours/ Week	4	Semester End Exam Marks	70
Total Number of Lecture Hours	60	Total Marks	100
Year of Introduction : 2019-20	Year of Offering 2021-2022	Year of Revision – 2021-22	Percentage of Revision: 100%

Course Outcomes:

This course will provide students with a deep knowledge in immunology, genetics, embryology and ecology and by the completion of the course the graduates shall be able to –

CO1: To get knowledge of the organs of the immune system, types of immunity, cells and organs of immunity.

CO2: To describe immunological responses and how they are triggered (antigens) and regulated (antibodies)

CO3: Understand the applications of Biotechnology in the fields of industry and agriculture including animal cell/tissue culture, stem cell technology and genetic engineering.

CO4: Get familiar with the tools and techniques of animal biotechnology.

Learning Objectives

- To trace the history and development of immunology
- To provide students with a foundation in immunological processes
- To be able to compare and contrast the innate versus adaptive immune systems and humoral versus cell-mediated immune responses
- Understand the significance of the Major Histocompatibility Complex in terms of immune response and transplantation
- To provide knowledge on animal cell and tissue culture and their preservation
- To empower students with latest biotechnology techniques like stem cell technology, genetic engineering, hybridoma technology, transgenic technology and their application in medicine and industry for the benefit of living organisms
- To explain *in vitro* fertilization, embryo transfer technology and other reproduction manipulation methodologies.
- To get insight in applications or recombinant DNA technology in agriculture, production of therapeutic proteins.
- To understand principles of animal culture, media preparation

Syllabus
Course Details

Unit	Learning Units	Lecture Hours
I	Immunology –I(OverviewofImmunesystem) IntroductiontobasicconceptsInImmunology Innateandadaptiveimmunity,VaccinesandImmunizationprogramme Cellsofimmunesystem Organsofimmunesystem	10
II	Immunology –II (Antigens,Antibodies, MHCandHypersensitivity) Antigens:Basicpropertiesofantigens,BandTcellepitopes,haptensandadjuvants;Factors influencingimmunogenicity Antibodies:Structureof antibody,Classesand functionsofantibodies Structureandfunctionsofmajor histocompatibilitycomplexes ExogenousandEndogenouspathwaysofantigenpresentationandprocessing Hypersensitivity–ClassificationandTypes	15
III	Techniques AnimalCell,TissueandOrganculturemedia:NaturalandSyntheticmedia, Cellcultures:Establishmentofcellculture(primaryculture,secondaryculture, types of cell lines; Protocols for Primary Cell Culture); EstablishedCell lines (common examples such as MRC, HeLa, CHO, BHK, Vero); Organculture;Cryopreservation of cultures Stemcells:Typesofstemcellsandapplications Hybridoma Technology: Production & applications of Monoclonal antibodies(mAb)	15
IV	Genetic Engineering:Basic concept, Vectors, Restriction Endonucleases andRecombinantDNATEchnology Gene delivery:Microinjection, electroporation, biolistic method (gene gun),liposomeand viral-mediated genedelivery Transgenic Animals:Strategies of Gene transfer; Transgenic - sheep, - fish; applications Manipulationofreproductioninanimals:Artificial Insemination, <i>Invitro</i> fertilization,superovulation,Embryotransfer,Embryo cloning	10
V	PCR:BasicsofPCR. DNA Sequencing: Sanger’s method of DNA sequencing- traditional andautomatedsequencing (2 hrs) Hybridizationtechniques:Southern,Northernand Westernblotting DNafingerprinting:Procedureandapplications Applicationsin IndustryandAgriculture: Fermentation:Different types of Fermentation and Downstream processing; Agriculture: Monocultureinfishes, polyploidyinfishes	10

A.G. &S.G.Siddhartha Degree College of Arts & Science, Vuyyuru – 521165, Krishna Dt. A.P. (Autonomous)

Semester IV *w.e.f. 2021-2022*

(Model question paper)

Title of the paper: IMMUNOLOGY AND ANIMAL BIOTECHNOLOGY

Code – ZOO-402C

Time: 3hrs.

max.marks: 70

Section – A

4 x 5 = 20.

Answer any **four** questions. Each question carries **five** marks. Draw neat labeled diagrams wherever necessary.

1. Organs of immune system
2. Haptens
3. Types of stem cells
4. BHK
5. Electroporation
6. Transgenic - sheep
7. Western blotting
8. polyploidy in fishes

Section – B 5 x 10 = 50.

Answer any **five** questions. Each question carries **Ten** marks. Draw neat labeled diagrams wherever necessary.

9. Give an account of Innate and adaptive immunity?
10. Describe the cells of immune system ?
11. Explain about the Structure and function of major histocompatibility complexes?
12. Explain about the Hypersensitivity – Classification and Types?
13. Give an account of Cryopreservation of cultures ?
14. Discourse about Production & applications of Monoclonal antibodies (mAb)
15. Explain about endonucleases and Recombinant DNA technology?
16. Different types of Fermentation and Downstream processing ?

**A.G. & S.G.Siddhartha Degree College of Arts & Science, Vuyyuru – 521165,
Krishna Dt. A.P. (Autonomous)
Semester -IV**

Guide lines to the Paper Setter.

w.e.f. 2021-2022

Title of the paper:IMMUNOLOGYANDANIMALBIOTECHNOLOGYCode – ZOO-402C

Time: 3hrs.

Max. Marks: 70.

1. Answer any **four** questions out of eight in Section – A. Each question carriesfive marks. 4x5 = 20M.

2. Answer any **five** questions out of eight in Section – B. Each question carriesTen marks. 5x10= 50M.

	Section	UNIT-I	UNIT-II	UNIT-III	UNIT-IV	UNIT-V
5 Marks Questions	A	1	1	2	2	2
10 Marks Questions	B	2	2	2	1	1
Weightage		25	25	30	20	20

- Note:** 1. please provide the scheme of valuation for the paper.
2. Question paper should be in English medium.

PRACTICAL - IV

w.e.f. 2021-2022. Code: ZOO- 402P

IMMUNOLOGY AND ANIMAL BIOTECHNOLOGY

MAX. MARKS: 50.

(2hrs/week)

PRACTICAL SYLLABUS

Learning Objectives:

- Acquainting student with immunological techniques vis-à-vis theory taught in the classroom
- Interconnect the theoretical and practical knowledge of immunity with the outer world for the development of a healthier life.
- Demonstrate basic laboratory skills necessary for Biotechnology research
- Promoting application of the lab techniques for taking up research in higher studies

I. IMMUNOLOGY

1. Demonstration of lymphoid organs (as per UGC guidelines)
2. Histological study of spleen, thymus and lymph nodes (through prepared slides)
3. Blood group determination
4. Demonstration of
 - a. ELISA
 - b. Immunoelectrophoresis

II. Animal biotechnology

1. DNA quantification using DPAM method.
2. Techniques: Western Blot, Southern Hybridization, DNA Fingerprinting
3. Separation, Purification of biological compounds by paper, Thin-layer and Column chromatography
4. Cleaning and sterilization of glass and plastic wares for cell culture.
5. Preparation of culture media.

REFERENCE BOOKS

1. Immunology Lab Biology 477 Lab Manual; Spring 2016 Dr. Julie Jameson
2. Practical Immunology A Laboratory Manual; LAP LAMBERT Academic

Publishing

3. Manual of laboratory experiments in cell biology by Edward, G Laboratory Techniques by Plummer

A. G & S. G. S. DEGREE COLLEGE OF ARTS & SCIENCE, VUYURU 521165, KRISHNA Dt., A.P.
(AUTONOMOUS)
PAPER – IV

(IMMUNOLOGY AND ANIMAL BIOTECHNOLOGY)

w.e.f.2021-22.

Model Question paper (External) Max.Marks: 25 M.

Paper Code: ZOO-402P

-
- | | |
|--|-------|
| 1. Blood group determination. | 5 m |
| 2. Demonstration of ELISA. | 5m |
| 3. Preparation of culture media. | 5m |
| 4. Study the following techniques given on photographs & Write notes on. | 4X2=8 |
| .A.spleen, | |
| B.Lymph nodes | |
| C.Western Blot, | |
| D. DNA Fingerprinting | |
| 5. Cleaning of glasswares for cell culture. | 2m |

A. G. & S.G. SIDDHARTHA DEGREE COLLEGE OF ARTS & SCIENCE, VUYURU-521165

ZOOLOGY PRACTICAL -IV

(INTERNAL)

w.e.f. 2021-2022.

(2hrs/week).

(IMMUNOLOGY AND ANIMAL BIOTECHNOLOGY)

Code: ZOO-402P.

Max.marks:25M.

Time: 3hrs.

- | | | |
|---------------|-------|------|
| 4. Attendance | ----- | 5M. |
| 5. Record | ----- | 10M. |
| 6. Assignment | ----- | 10M. |
| Total | ----- | 25M. |

**ADUSUMILLI GOPALAKRISHNAIAH & SUGAR CANE GROWERS SIDDHARTHA DEGREE
COLLEGE OF ARTS & SCIENCE, VUYYURU-521165, KRISHNA Dt., A.P. (AUTONOMOUS).**

NAAC recredited at 'A' level
Autonomous –ISO 9001-2015 Certified

Title of the Paper: **Immunology**

Semester: - VI

Course Code	ZOO-601C	Course Delivery Method	Class Room/Blended Mode - Both
Credits	3	CIA Marks	30
No. of Lecture Hours/ Week	4	Semester End Exam Marks	70
Total Number of Lecture Hours	60	Total Marks	100
Year of Introduction : 2019	Year of Offering 2021-2022	Year of Revision – 2021-22	Percentage of Revision: 0%

Objective of the course: To facilitate students to understand the role of immune system in the body, cells and organs of immune system, their structures and functioning

Course out comes:

- Students grow in understanding of immune system, to improve their immunity and to protect them from pathogens.
- They identify their blood groups, their compatibility and the need to donate blood to save life.
- Students identify the classes, structures and functions of antibodies, antigen – antibody reactions.
- This study enables students to take care of themselves and take timely precautions against various diseases.
- They identify the cure of different diseases through various vaccines, the instruments involved in identification of immune reactions etc.

Syllabus
Course Details

Unit	Learning Units	Lecture Hours
I	UNIT- I: Overview of Immune system Introduction to basic concepts in Immunology. Innate and adaptive immunity *Cells and organs of Immune system Cells of immune system Organs of immune system	10
II	UNIT-II:Antigens Basic properties of antigens B and T cell epitopes, haptens and adjuvants Factors influencing immunogenicity	10
III	UNIT-III: Antibodies Structure of an antibody Classes and functions of antibodies Antigen and antibody interactions. Monoclonal antibodies and their production.	15
IV	UNIT-IV: Working of an Immune system Structure and functions of major histocompatibility complexes Exogenous and Endogenous pathways of antigen presentation and processing Basic properties and functions of mediator molecules. (cytokines, interferons and complement proteins). Mechanisms of humoral and cell mediated immunities	15
V	UNIT-V: Immune system in health and disease Classification and brief description of various types of hyper sensitivities Introduction to concepts of autoimmunity and immunodeficiency *Vaccines General introduction to vaccines Types of vaccines	10

**A.G& S.G.S.DEGREE COLLEGE OF ARTS & SCIENCE, VUYURU – 521165,
KRISHNA Dt.,A.P. (AUTONOMOUS)
SEMESTER-VI (Model Question paper)**

Paper Title: Immunology

Paper Code:ZOO-601GEw.e.f. 2021 – 2022.

Time: 3 hrs

Max.Marks:70

SECTION-A

Answer **any four** questions out of eight in Part - A. Each question carries five marks. **4 X 5 = 20m**

1. Active immunity
2. Monoclonal antibodies .
3. T Cell Epitope
4. Structure of antibody.
5. Functions of major histo compatibility complexes (MHC)
6. Humoral immunity.
7. Causes of autoimmune diseases .
- 8 .BCG Vaccine .

Part – B

Answer **any five** questions out of eight in Part – B. Each question carries ten marks **5 X 10 =50m**

9. Give an account of innate immunity.
10. Write an essay on primary lymphoid organs.
11. Discuss about the basic properties of Antigen.
12. Write an essay on immunogenicity.
13. Describe about different types of immunoglobulins.
14. Give an account of basic properties and functions of Cytokines.
15. Define Hypersensitivity. Explain it in detail.
16. Explain different types of vaccines.

**A.G & S.G.S.DEGREE COLLEGE OF ARTS & SCIENCE, VUYYURU 521165, KRISHNA Dt.,
A.P. (AUTONOMOUS)**

**SEMESTER-VI
ZOOLOGY ELECTIVE PAPER-VII (A)**

Guide lines to the paper setter w.e.f. 2021 – 2022.

Paper Title: Immunology. **Paper Code:** ZOO-601GE

Time: 3 hrs

Max.Marks:70

Note: 1. Answer **any four** questions out of eight in Part-A. Each question carries five mark 4 X 5= 20M.

2. Answer any **five** questions out of eight in Part-B. Each question carries 10 marks. 5 X 10= 50M.

	PART	Unit – I	Unit – II	Unit – III	Unit – IV	Unit – V
5 Marks Questions	A	1	1	2	2	2
10 Marks Questions	B	2	2	1	1	2
Weightage		25	25	20	20	30

Note: 1. please provide the scheme of valuation for the paper.

2. Question paper should be both in English and Telugu media.

A. G & S. G. S. DEGREE COLLEGE OF ARTS & SCIENCE, VUYYURU 521165, KRISHNA Dt.,
A.P. (AUTONOMOUS)

ZOOLOGY PRACTICAL SYLLABUS

PAPERS – VI

w.e.f. 2021 – 2022.

Period: 24

Max.Marks:50

Credits: 2

Paper Title: Immunology.

Paper Code: ZOO-601GE (P)

Part – A

1. Demonstration of lymphoid organs (as per UGC guidelines).
2. Histological study of spleen, thymus and lymph nodes (through prepared slides).
3. Blood group determination.
4. Demonstration of
 - a. ELISA
 - b. Immunoelectrophoresis

REFERENCES BOOKS

William F. Ganong, *A Review of Medical Physiology*, 22 ed, McGraw Hill, 2005
Sherwood, Klandrof, Yanc, *Human Physiology*, Thompson Brooks/Coole, 2005.
Knut Schmidt-Nielson, *Animal Physiology*, 5th ed, Cambridge Low Price Edition.
Richard A. Glodsby, Thomas J Kind, Barbara A. Osborne, Janis Kuby, *Immunology*, 5th ed, Freeman and Co. New York
Ivan Roitt, *Immunology*, 4th ed, JohanthanBrostoff, Moshy, London.
Thomas C. Chung, *General Parasitology*, Hardcourt Brace and Co ltd. Asia. New Delhi.
Gerard D. Schmidt and Larry S Roberts, *Foundations of Parasitology*, McGraw Hill
Kindt, T. J., Goldsby, R. A., Osborne, B. A., Kuby, J. (2006). VI Edition. Immunology. W.H. Freeman and Company.
Delves, P. J., Martin, S. J., Burton, D. R., Roitt, I.M. (2006). XI Edition. Roitt's Essential Immunology, Blackwell Publishing.

**A.G & S. G.S.DEGREE COLLEGE OF ARTS & SCIENCE, VUYYURU - 521165, KRISHNA Dt.,
A.P. (AUTONOMOUS)**

Model Question Paper (External)

Immunology

Practical - VI

w.e.f. 2021 – 2022.
Paper Code: ZOO-601GE (P)
Max.marks:25m

-
1. Demonstration of lymphoid organs (as per UGC guidelines)5m
2. Blood group determination 5m
3. Study the following techniques given on photographs & Write notes on. 2x5=10m
A & B
4. ELISA & Immuno electrophoresis (demonstration) on site or of site demonstration. 5m
- Total: 25m.
Total: 25m
-

Guide lines for the Practical Examiners.

1. Demonstration of lymphoid organs
(5 marks for Procedure)
2. Blood group determination. .
(5 marks for Procedure)
3. Study the following techniques given on photographs & Write notes on A & B.
(1 mark for identification & 4 marks for diagram and notes, for each photographs)
4. ELISA (demonstration) on site or of site demonstration.
(5 marks for ELISA demonstration)
-

A.G & S. G.S.DEGREE COLLEGE OF ARTS & SCIENCE, VUYYURU - 521165, KRISHNA Dt.,
A.P. (AUTONOMOUS)

Immunology.

Model Question Paper (Internal)
Practical - VI

Paper Code: ZOO-601GE (P)
Max. Marks: 25

1. Attendance	--	5 M
2. Record	--	10M
3. Assignments	--	10M
Total	--	25M

**A.G& S.G.SIDDHARTHA DEGREE COLLEGE OF ARTS &
SCIENCE**

VUYYURU-521165, KRISHNA Dt., A.P.(Autonomous)

Accredited by NAAC with "A" Grade

2021-2022



DEPARTMENT OF CHEMISTRY

MINUTES OF BOARD OF STUDIES

ODD SEMESTER

03-11-2021

Minutes of the Meeting of Board of Studies in Chemistry for the Autonomous Course

A.G. & S.G. Siddhartha Degree College of Arts & Science, Vuyyuru Held at 11.00 A.M on 03-11-2021 in
the Department of Chemistry.

K.RAMESH Presiding

Members Present:

- 1) K. Ramesh Chairman HOD, Dept. of Chemistry,
(Sri. K.RAMESH) A.G. & S.G.S.Degree College, Vuyyuru.
- 2) Prof.D.Ramasekhar Reddy University Nominee Assistant Professor,
Dept. of Chemistry, Krishna University, MTM.
- 3) Dr. S. Kalpana Academic Council Nominee HOD, Dept. of Chemistry,
(Dr. S. Kalpana) SDMS M College, Vijayawada.
- 4) Smt. A. Indira Academic Council Nominee Lecturer in Chemistry,
(Smt. A. Indira) G.D.C, Dumpagadapa
- 5) Dr. G Raja Industrialist Manager, Q.A, Biophore india
(Dr. G Raja) Pharmaceuticals pvt ltd Hyd,
- 6) Smt. M. Sowjanya Student Nominee Lecturer in Chemistry,
(Smt. M. Sowjanya) ANR College Gudivada.
- 7) Dr. G.Giri prasad Member Lecturer in Chemistry,
(Dr. G.Giri prasad) A.G. & S.G.S.Degree College, Vuyyuru
- 8) Smt. M.V.Santhi Member Lecturer in Chemistry,
(Smt. M.V.Santhi) A.G. & S.G.S.Degree College, Vuyyuru.
- 9) Sri. P.Suresh Member Lecturer in Chemistry,
(Sri. P.Suresh) A.G.& S.G.S.Degree College, Vuyyuru.
- 10) MS. M.Santhi Member Lecturer in Chemistry,
(MS. M.Santhi) A.G. & S.G.S.Degree College, Vuyyuru:
- 11) Sri. J.Nageswara Rao Member Rtd.Lecturer in Chemistry,
(Sri. J.Nageswara Rao) A.G. & S.G.S.Degree College, Vuyyuru.

Agenda for B.O.S Meeting

1. To recommend the syllabus and model paper for I semester of I Degree B.Sc., Chemistry for the Academic year 2021-2022.
2. To recommend the syllabus and model papers for III semester of II Degree B.Sc., Chemistry for the Academic year 2021-2022.
3. To recommend the syllabus and model papers for V semester of III Degree B.Sc. Chemistry for the Academic year 2021-2022.
4. To recommend the Blue print of I, III, V semesters of B.Sc. Chemistry for the Academic year 2021-2022.
5. To recommend the Guidelines to be followed by the question paper setters in Chemistry for I, III, V Semester-end exams.
6. To recommend the teaching and evaluation methods to be followed under Autonomous status.
7. Any suggestions regarding certificate course, seminars, workshops, Guest lecture to be organized.
8. Recommend the panel of paper setters and Examiners to the controller of Examinations of autonomous Courses of A.G. & S.G.S. Degree colleges of Arts & Science, Vuyyuru.
9. Any other matter.

K. Ramell
Chairman.

RESOLUTIONS

- 1) It is resolved to Change the **syllabus of academic year 2020-2021 for I semesters of I B.Sc.** under Choice Based Credit System (CBCS) for the Academic year 2021–2022.
 - **Adding Syllabus:** P-block elements in unit-1, Dilute Solutions.
 - **Deleting Syllabus:** Inorganic Polymers and Collegative Properties.
- 2) It is resolved to implement the changed **syllabus and model papers** under Choice Based Credit System (CBCS) from this Academic year onwards for **III semester of II B.Sc** for the Academic year 2021-2022.
 - It is resolved to implement the new paper with title Organic chemistry and Spectroscopy with paper code CHE-301.
- 3) It is resolved to implement the same **syllabus (theory and practical)** under Choice Based Credit System for the Academic year 2021-2022 for **V semester of III B.Sc.**
- 4) It is resolved to follow the **Blue prints** as proposed by members of BOS I, III & V semester of Degree B.Sc. for the Academic year 2021-2022.
- 5) It is resolved to follow the guidelines to be followed by the question paper setters of Chemistry for I, III & V semesters of Degree B.Sc. for the Academic Year 2021-2022.
- 6) It is resolved to continue the following teaching and evaluation methods for Academic year 2021-22.

Teaching Methods:

Besides the conventional methods of teaching, we use modern technology i.e. using of LCD projector to display on U boards etc, for better understanding of concepts.

Evaluation of a student is done by the following procedure:

• Internal Assessment Examinations:

- Out of maximum 100 marks in each paper for I B.Sc, 25 marks shall be allocated for internal assessment. Out of these 25 marks, 15 marks are allocated for announced tests (i.e. IA-1 & IA-2).
- Out of maximum 100 marks in each paper for II, III B.Sc, 30 marks shall be allocated for internal assessment. Out of these 30 marks, **20 marks are allocated for announced tests (i.e. IA-1 & IA-2).**
- Two announced tests will be conducted and average of these two tests shall be deemed as the marks obtained by the student, **5 marks are allocated on the basis of candidate's percentage of attendance and remaining 5 marks are allocated for the innovative component like assignment/quiz/seminars for I, II, III B.Sc.**
- There is **no pass minimum** for internal assessment for I, II, III B.Sc.

Semester – End Examination:

- The maximum marks for I B.Sc Semester – End examination shall be 75 marks and 70 marks for II, III B.Sc., duration of the examination shall be 3 hours. Even though the candidate is absent for two IA exams / obtain Zero marks the external marks are considered (if the candidate gets 40/70) and the result shall be declared as "PASS".
- Semester – End examinations shall be conducted in theory papers at the end of every semester, while in practical papers, these examinations are conducted at the end of I, III, & V semesters for I, II & III B.Sc for 50 marks.
- Discussed and recommended for organizing **certificate course, seminars, Guest lecturers, workshops** to upgrade the knowledge of students, for the approval of the academic council.
- Discussed and empowered the Head of the department of Chemistry to suggest the panel of paper setters and examiners to the controller of examinations. **Department of Chemistry Adopted Value Added Course "Water Analysis".**
- NIL.

K. Ramell
Chairman

**A.G.&S.G.SIDDHARTHA DEGREE COLLEGE OF ARTS & SCIENCE
(AUTONOMOUS), VUYYURU.
(Accredited at "A" Grade by NAAC, Bangalore)**

SEMESTER – I	SUBJECT: CHEMISTRY	COURSE CODE:
PAPER TITLE : INORGANIC &PHYSICAL CHEMISTRY, PAPER-I		
ACADEMIC YEAR-2021-2022		

60 hrs(4h/w)

Credits-3

COURSE OUTCOMES:

At the end of the course, the student will be able to;

1. Understand the basic concepts of p-block elements.
2. Explain the difference between solid, liquid and gases in terms of inter molecular interactions.
3. Apply the concepts of gas equations, pH and electrolytes while studying other chemistry courses.

INORGANIC CHEMISTRY

24h

UNIT – I

1. Chemistry of p-block elements

8h

Group 13: Preparation & structure of Diborane, Borazine

Group 14: Preparation, classification and uses of silicones

Group 15: Preparation & structures of Phosphonitrilic halides $\{(PNCI_2)_n\}$ where $n=3, 4$

Group 16: Oxides and Oxoacids of Sulphur (structures only)

Group 17: Pseudo halogens, Structures of Interhalogen compounds.

UNIT-II

1. Chemistry of d-block elements:

6h

Characteristics of d-block elements with special reference to electronic configuration, variable valence, magnetic properties, catalytic properties and ability to form complexes. Stability of various oxidation states.

2. Chemistry of f-block elements: 6h

Chemistry of lanthanides - electronic structure, oxidation states, lanthanide contraction, consequences of lanthanide contraction, magnetic properties. Chemistry of actinides - electronic configuration, oxidation states, actinide contraction, comparison of lanthanides and actinides.

3. Theories of bonding in metals: 4h

Valence bond theory and free electron theory, explanation of thermal and electrical conductivity of metals based on these theories, Band theory- formation of bands, explanation of conductors, semiconductors and insulators.

PHYSICAL CHEMISTRY 36h

UNIT-III

Solid state 10h

Symmetry in crystals. Law of constancy of interfacial angles. The law of rationality of indices. The law of symmetry. Miller indices, Definition of lattice point, space lattice, unit cell. Bravais lattices and crystal systems. X-ray diffraction and crystal structure. Bragg's law. Powder method. Defects in crystals. Stoichiometric and non-stoichiometric defects.

UNIT-IV

1. Gaseous state 6h

Van der Waal's equation of state. Andrew's isotherms of carbon dioxide, continuity of state. Critical phenomena. Relationship between critical constants and vander Waal's constants. Law of corresponding states. Joule- Thomson effect. Inversion temperature.

2. Liquid state 4h

Liquid crystals, mesomorphic state. Differences between liquid crystal and solid/liquid. Classification of liquid crystals into Smectic and Nematic. Application of liquid crystals as LCD devices.

UNIT-V

Solutions, Ionic equilibrium & dilute solutions

1. Solutions 6h

Azeotropes-HCl-H₂O system and ethanol-water system. Partially miscible liquids-phenol-water system. Critical solution temperature (CST), Effect of impurity on consolute temperature. Immiscible liquids and steam distillation. Nernst distribution law. Calculation of the partition coefficient. Applications of distribution law.

2. Ionic equilibrium

3h

Ionic product, common ion effect, solubility and solubility product. Calculations based on solubility product.

3. Dilute solutions

7h

Colligative properties- RLVP, Osmotic pressure, Elevation in boiling point and depression in freezing point. Experimental methods for the determination of molar mass of a non-volatile. Solute using osmotic pressure, Elevation in boiling point and depression in freezing point. Abnormal colligative properties. Van't Hoff factor.

Co-curricular activities and Assessment Methods

1. Continuous Evaluation: Monitoring the progress of student's learning.
2. Class Tests, Work sheets and Quizzes.
3. Presentations, Projects and Assignments and Group Discussions: Enhances critical thinking skills and personality.
4. Semester end Examination: critical indicator of student's learning and teaching methods adopted by teachers throughout the semester.

List of Reference Books

1. Principles of physical chemistry by Prutton and Marron
2. Solid State Chemistry and its applications by Anthony R. West
3. Text book of physical chemistry by K L Kapoor
4. Text book of physical chemistry by S Glasstone
5. Advanced physical chemistry by Bahl and Tuli
6. Inorganic Chemistry by J.E.Huheey
7. Basic Inorganic Chemistry by Cotton and Wilkinson
8. A textbook of qualitative inorganic analysis by A.I. Vogel
9. Atkins,P.W.&Paula,J.deAtkin'sPhysicalChemistryEd.,OxfordUniversityPress
10thEd(2014).
10. Castellan,G.W.PhysicalChemistry4thEd.Narosa(2004).
11. Mortimer,R. G.PhysicalChemistry3rdEd. Elsevier:NOIDA,UP(2009).
12. Barrow,G.M.PhysicalChemis

**A.G. & S.G.SIDDHARTHA DEGREE COLLEGE OF ARTS & SCIENCE
(AUTONOMOUS), VUYYURU.**

SEMESTER-I	PAPER-I	PAPER CODE : CHE-101C
PAPER TITLE : INORGANIC & PHYSICAL CHEMISTRY		
ACADEMIC YEAR-2021-2022		

Time: 3Hours

Maximum marks: 75

Pass marks:

Time: 3 Hours

Max. Marks: 75M

PART- A

Answer any FIVE of the following questions. Each carries FIVE marks 5 X 5 = 25 Marks

1. Explain the preparation & structures of Phosphonitrilic compounds. **L2- CO1**
2. Explain in brief, catalytic properties & stability of various oxidation states of d- block elements.
L2-CO2
3. Define Unit Cell , Space Lattice and Lattice Point. **L1- CO3**
4. What are Smectic & Nematic liquid Crystals? Explain. **L1- CO4**
5. Write account on Common ion effect & Solubility product. **L2- CO5**
6. Write a short note on Law of Corresponding States. **L1- CO4**
7. Explain Actinide Contraction. **L2- CO2**
8. Explain the structure of Borazine. **L2- CO1**

PART-B

Answer All of the following questions. Each carries TEN marks

5 X 10 = 50 Marks

9. (a). Explain Classification, Preparations & uses of Silicones **L2- CO1**

(or)

(b). (i). What are Pseudohalogens. **L2- CO1**

(ii). Explain the Structures of any one AX₃& AX₅ interhalogen compounds. **L2- CO1**

10. (a).What is Lanthanide Contraction? Explain the Consequences of Lanthanide Contraction.

L2- CO2

(or)

(b). (i). Explain the magnetic properties of d- block elements. **L2- CO2**

(ii). Explain about Conductors, Semi-Conductors& Insulators using Band Theory. **L2- CO2**

11. (a). Write an essay on Crystal defects. **L1- CO3**

(or)

(b). what is Bragg's Law. Explain the determination of structure of a crystal by powder method.

L2- CO3

12. (a). Derive the relationship between Critical constants & Vander Waal's constants **L1- CO4**.

(or)

(b). (i). Write any 5 differences between liquid crystals & liquids, solids

(ii). Write the applications of Liquid crystals. **L2- CO4**

13. (a). Explain Nernst distribution Law. Explain its applications. **L2- CO5**

(or)

(b). What are colligative properties. Write experimental methods for determination of molar mass of a non-volatile solute by using Elevation in boiling point & depression in freezing point. **L2- CO5**

**A.G.&S.G.SIDDHARTHA DEGREE COLLEGE OF ARTS & SCIENCE
(AUTONOMOUS), VUYYURU.
(Accredited at "A" Grade by NAAC, Bangalore)
PRACTICAL SYLLABUS**

Practical Paper – I Analysis of SALTMIXTURE	PAPER CODE : CHE-101 P ACADEMIC YEAR-2021-2022
--	---

LABORATORY COURSE -I

30hrs (2 h / w)

Practical-I

(At end of Semester-I)

Qualitative inorganic analysis (Minimum of Six mixtures should be analysed)

Course outcomes:

At the end of the course, the student will be able to;

1. Understand the basic concepts of qualitative analysis of inorganic mixture.
2. Use glassware, equipment and chemicals and follow experimental procedures in the laboratory.
3. Apply the concepts of common ion effect, solubility product and concepts related to qualitative analysis.

Analysis of SALT MIXTURE

50 M

Analysis of mixture salt containing two anions and two cations (From two different groups) from the following:

Anions: Carbonate, Sulphate, Chloride, Bromide, Acetate, Nitrate, Borate, Phosphate.

Cations: Lead, Copper, Iron, Aluminium, Zinc, Nickel, Manganese, Calcium, Strontium, Barium, Potassium and Ammonium.

**A.G.&S.G.SIDDHARTHA DEGREE COLLEGE OF ARTS & SCIENCE
(AUTONOMOUS), VUYYURU.
(Accredited at "A" Grade by NAAC, Bangalore)**

SEMESTER – III	SUBJECT: CHEMISTRY	COURSE CODE: CHE-
301C		
PAPER TITLE : ORGANIC CHEMISTRY & SPECTROSCOPY, PAPER-III		
ACADEMIC YEAR-2021-2022		

60 hrs(4h/w)

Credits-3

ORGANIC CHEMISTRY

UNIT – I

1. Chemistry of Halogenated Hydrocarbons: 6h

Nomenclature, any two preparations of Alkyl halides, Aryl halides,

Chemical properties

Marks Weightage-5

a. Williamson's synthesis b. substitution vs elimination.

c. Relative reactivity of alkyl, allyl, vinyl, benzyl and aryl halides towards nucleophilic substitution reactions.

Mechanisms

(Marks Weightage-10)

SN¹, SN², and SNⁱ Nucleophilic substitution reactions with stereo chemical aspects and effect of solvent.

2. Chemistry of Alcohols & Phenols

6h

Nomenclature, any two preparations of Alcohols & Phenols

Chemical properties

(Marks Weightage-5)

a. Acidity of phenols and factors affecting it b. Ring substitution reactions (Bromination, Nitration) c. Fries rearrangements d. Kolbe's-Schmidt Reactions, e. Oxidation of diols by periodic acid and lead tetra acetate,

Mechanisms

(Marks Weightage-10)

Reimer-Tieman reaction, Claisen rearrangements, and Pinacol-Pinacolone rearrangement.

UNIT-II

Carbonyl Compounds

6h

Nomenclature, any two preparations of (Carbonyl Compounds) Aldehyde and ketones.

Chemical properties

(Marks Weightage-5)

A. Nucleophilic addition reactions of A. NaHSO_3 , HCN , RMgX B. Nucleophilic addition reactions with ammonia derivatives, C. Wittig Reaction, Halo form Reaction, Beckmann rearrangements, Michael-addition, Benzoin condensation, Perkin Reaction. and Reformatsky reactions. Reduction reactions: Clemmenson, wolf-kishner, LiAlH_4 and NaBH_4 .

Mechanisms

(Marks Weightage-10)

Aldol condensation, Cannizzaro Reaction, Baeyer-Villiger oxidation.

UNIT-III

Carboxylic Acids and their Derivatives

16h

Nomenclature, any two preparations of Carboxylic Acids, and their derivatives.

Chemical properties

(Marks Weightage-5)

A. Reactions involving H, OH and COOH groups- salt formation, anhydride formation, acid chloride formation, amide formation and esterification,

B. Huns-Diecker reaction, Schimdt reaction, Curtius rearrangement, Arndt-Eistert synthesis, C. Typical Reactions of dicarboxylic acids, hydroxy acids and unsaturated acids. Reactions of acid chlorides, anhydrides, esters and amides.

Mechanisms

(Marks Weightage-10)

Mechanism of acidic and alkaline hydrolysis of esters, Hell-Volhard- Zelinsky.

Active methylene compounds

(Marks Weightage-10+5)

Acetoacetic esters: keto-enol tautomerism, preparation by Claisen condensation (mechanism), Acid hydrolysis and ketonic hydrolysis. Synthetic applications:Preparation of a) monocarboxylic acids (Acetic acid, Propanoic acid) b) Dicarboxylic acids (Succinic acid, Adipic acid).

C) Reaction with urea.

Malonic ester: preparation from acetic acid.

Synthetic applications: Preparation of a) monocarboxylic acids (Acetic acid, Propanoic acid)

b) Dicarboxylic acids (succinic acid and adipic acid) C.Reaction with urea.

SPECTROSCOPY

UNIT-IV

Spectrophotometry **6h** **(Marks Weightage-5+5)**

General feature of absorption-Beer-Lambert's law and its application, transmittance Absorbance, and molecular absorptivity. Single and double beam Spectrophotometers. Applications of Beer-Lambert's for Quantitative analysis of 1. Chromium in $K_2Cr_2O_7$ 2. Manganese in Manganous sulphate.

Electronic spectroscopy: **6h** **(Marks Weightage-10)**

Interactions of electromagnetic radiations with molecules and types of molecular spectra. Energy levels of molecular orbital (σ , π , n). Selection rules for electronic spectra. Types of electronic transitions in molecules, effect of conjugation. Concept of chromophore and auxochrome.

Nuclear Magnetic Resonance (NMR) spectroscopy: **6h** **(Marks Weightage-10+5)**

Principles of nuclear magnetic resonance, equivalent and non-equivalent protons, position of signals. Chemical shift, NMR splitting of signals - spin-spin coupling, coupling constants. Applications of NMR with suitable examples - ethyl bromide, ethanol, acetaldehyde, 1,1,2-tribromo ethane, ethyl acetate, toluene and acetophenone.

UNIT-V

8h

Application of Spectroscopy to Simple Organic Molecules **(Marks Weightage-10)**

Application of visible, ultraviolet and infrared spectroscopy in organic molecules.

Application of electronic spectroscopy and Wood ward rules for calculating λ_{max} of conjugated dienes and α,β – unsaturated compounds.

Infrared radiation and types of molecular vibrations, functional group and fingerprint region. IR spectra of alkanes, alkenes and simple alcohols (inter and intra molecular hydrogen bonding), aldehydes, ketones, carboxylic acids and their derivatives (effect of substitution on $>C=O$ stretching absorptions).

List of Reference Books

1. A Text Book of Organic Chemistry by Bahl and Arunbahl
2. A Text Book of Organic chemistry by I L Finar Vol I
3. Organic chemistry by Bruice
4. Organic chemistry by Clayden

5. Spectroscopy by William Kemp
6. Spectroscopy by Pavia
7. Organic Spectroscopy by J. R. Dyer
8. Elementary organic spectroscopy by Y.R. Sharma
9. Spectroscopy by P.S.Kalsi
10. Spectrometric Identification of Organic Compounds by Robert M Silverstein, Francis X Webster
11. Mann, F.G. & Saunders, B.C. Practical Organic Chemistry, Pearson Education (2009)
12. Furniss, B.S., Hannaford, A.J., Smith, P.W.G. & Tatchell, A.R. Practical Organic Chemistry, 5th Ed. Pearson (2012).
13. Ahluwalia, V.K. & Aggarwal, R. Comprehensive Practical Organic Chemistry: Preparation and Quantitative Analysis, University Press (2000).

**A.G. & S.G.SIDDHARTHA DEGREE COLLEGE OF ARTS & SCIENCE
(AUTONOMOUS), VUYYURU.**

SEMESTER – III	PAPER-III	PAPER CODE : CHE-301C
PAPER TITLE : ORGANIC CHEMISTRY & SPECTROSCOPY		
ACADEMIC YEAR-2021-2022		

Time: 3Hours

Maximum marks: 70

Minimum marks: 28

SECTION-A

Answer any FOUR of the following. Each question carries 5 marks.

4X5=20

1. Explain relative reactivity of aryl halides.
2. Explain ring substitution reaction (bromination) in phenols.
3. Explain the reaction Beckmann rearrangement.
4. Explain the reaction Curtius-rearrangement.
5. Explain Keto-enol Tautomerism.
6. Write a short note on single beam spectrophotometer.
7. Explain absorbance and molar absorptivity.
8. Write a short note on coupling constant.

SECTION-B

Answer any FIVE questions. Each question carries 10 marks.

5X10=50

9. Discuss the reaction and mechanism of S_N^i nucleophilic substitutions.
10. Discuss the reaction and mechanism of Reimer-Tiemann.
11. Explain Baeyer-villiger Oxidation reaction with mechanism.
12. Explain mechanism of ester hydrolysis through acidic medium.
13. Write the preparation of n- butyric acid, succinic acid and crotonic acid from malonic ester.
14. Explain the selection rules of electronic spectra.
15. Give the principle and theory involved in PMR spectroscopy.
16. Explain IR spectra of alkanes and alkenes.

The Guidelines to be followed by the question paper setters in chemistry for the

III- Semester - end exams

SEMESTER – III SUBJECT: CHEMISTRY COURSE CODE: CHE-301C
PAPER TITLE : ORGANIC CHEMISTRY & SPECTROSCOPY
ACADEMIC YEAR-2021-2022

Weightage for the question paper

syllabus	Section-A (Short answer questions)	Section-B (essay questions)
Unit-1 (30 Marks)	1+1	1+1
Unit-2 (15 Marks)	1	1
Unit-3 (30 Marks)	1+1	1+1
Unit-4 (35 Marks)	1+1+1	1+1
Unit-5 (10 Marks)	---	1

- Each Short answer question carries 5 marks in Section –A
- Each Essay question carries 10 marks in Section –B
- The Question papers setters are requested to cover all the topics in the syllabus stipulated as per the weightage given by us.

**A.G.&S.G.SIDDHARTHA DEGREE COLLEGE OF ARTS & SCIENCE
(AUTONOMOUS), VUYYURU.
(Accredited at "A" Grade by NAAC, Bangalore)
PRACTICAL SYLLABUS**

Practical Paper – III Organic preparations and IR Spectral Analysis	PAPER CODE : CHE-301 P ACADEMIC YEAR-2021-2022
--	---

30 hrs (2 h/W) Credits: 2

Organic preparations:

- i. Acetylation of one of the following compounds: amines (aniline, o-, m-, p-toluidines and o-, m-, p-anisidine) and phenols (β -naphthol, vanillin, salicylic acid) by any one method: a. Using conventional method. b. Using green approach
- ii. Benzoylation of one of the following amines (aniline, o-, m-, p-toluidines and o-, m-, p-anisidine).
- iii. Nitration of any one of the following: a. Acetanilide/nitrobenzene by conventional method b. Salicylic acid by green approach (using ceric ammonium nitrate).

IR Spectral Analysis

IR Spectral Analysis of the following functional groups with examples

- a) Hydroxyl groups
- b) Carbonyl groups
- c) Amino groups
- d) Aromatic groups

SCHEME OF VALUATION

1. INTERNAL MARKS- Record-10M
2. EXTERNAL MARKS-40
 - preparations of an organic compound -25M
 - Viva questions = 10 M
 - Project = 5M

TOTAL = 50 M__
A.G. & S.G.SIDDHARTHA DEGREE COLLEGE OF ARTS & SCIENCE
(AUTONOMOUS), VUYYURU.
(Accredited at "A" Grade by NAAC, Bangalore)

SEMESTER – V	SUBJECT: CHEMISTRY	COURSE CODE: CHE-
501C		
PAPER TITLE : INORGANIC,ORGANIC & PHYSICAL CHEMISTRY, Paper –V		
ACADEMIC YEAR-2021-2022		

INORGANIC CHEMISTRY

60 hrs(4h/w) Credits-3

UNIT – I

Coordination Chemistry: (10+10+5)

12h

IUPAC nomenclature - bonding theories - Review of Werner's theory and Sidg-wick's Concept of coordination - Valence bond theory - geometries of coordination numbers 4-tetrahedral and square planar and 6-octahedral and its limitations, crystal field theory - Splitting of d-orbitals in octahedral, tetrahedral and square-planar complexes - low spin and high spin complexes - factors affecting crystal-field splitting energy, merits and demerits of crystal-field theory. Isomerism in coordination compounds – structural isomerism and stereo isomerism, stereochemistry of complexes with 4 and 6 coordination numbers

UNIT-II

1. Magnetic properties of metal complexes: (10+5)

5h

Types of magnetic behavior, spin-only formula, calculation of magnetic moments, experimental determination of magnetic susceptibility-Gouy method.

2. Stability of metal complexes: (10+5)

6h

Thermodynamic stability and kinetic stability, factors affecting the stability of metal complexes, chelate effect, determination of composition of complex by Job's method and mole ratio method.

ORGANIC CHEMISTRY

UNIT- III

Nitro hydrocarbons: (10+5)

5h

Nomenclature and classification-nitro hydrocarbons, structure -Tautomerism of nitroalkanes leading to aci and keto form, Preparation of Nitroalkanes, reactivity-halogenation, reaction with

HONO (Nitrous acid), Nef reaction and Mannich reaction leading to Michael addition and reduction.

UNIT – IV

Nitrogen compounds: (10+10+5)

16h

Amines (Aliphatic and Aromatic): Nomenclature, Classification into 1°, 2°, 3° Amines and Quaternary ammonium compounds. Preparative methods – 1. Ammonolysis of alkyl halides 2. Gabriel synthesis 3. Hoffman's bromide reaction (mechanism). Reduction of Amides and Schmidt reaction. Physical properties and basic character - Comparative basic strength of Ammonia, methyl amine, dimethyl amine, tri methyl amine and aniline - comparative basic strength of aniline, N-methyl aniline and N,N-dimethyl aniline (in aqueous and non-aqueous medium), steric effects and substituent effects.

Chemical properties: a) Alkylation b) Acylation c) Carbylamines reaction d) Hinsberg separation e) Reaction with Nitrous acid of 1°, 2°, 3° (Aliphatic and aromatic amines). Electrophilic substitution of Aromatic amines – Bromination and Nitration. Oxidation of aryl and Tertiary amines, Diazotization.

PHYSICAL CHEMISTRY

UNIT- V

Thermodynamics (10+5+5)

16h

The first law of thermodynamics-statement, definition of internal energy and enthalpy. Heat capacities and their relationship. Joule-Thomson effect- coefficient. Calculation of w , for the expansion of perfect gas under isothermal and adiabatic conditions for reversible processes. State function. Temperature dependence of enthalpy of formation-Kirchhoff's equation. Second law of thermodynamics. Different Statements of the law. Concept of entropy, entropy as a state function, entropy changes in reversible and irreversible processes. Entropy changes in spontaneous and equilibrium processes.

List of Reference Books

1. Concise coordination chemistry by Gopalan and Ramalingam
2. Coordination Chemistry by Basalo and Johnson
3. Organic Chemistry by G. Mare loudan, Purdue Univ
4. Advanced Physical Chemistry by
5. Text book of physical chemistry by S Glasstone

6. Concise Inorganic Chemistry by J.D. Lee

**A.G. & S.G. SIDDHARTHA DEGREE COLLEGE OF ARTS & SCIENCE
(AUTONOMOUS), VUYYURU.
(Accredited at "A" Grade by NAAC, Bangalore)**

SEMESTER – V	PAPER-V	PAPER CODE : CHE-501C
PAPER TITLE : INORGANIC, ORGANIC & PHYSICAL CHEMISTRY		
ACADEMIC YEAR-2021-2022		

Time: 3 Hours

Maximum marks: 70

Minimum marks: 28

SECTION-A

Answer any FOUR of the following. Each question carries 5 marks.

4X5=20

1. Define Crystal field energy? Explain the factors affecting Crystal field energy?
2. Write short note on Magnetic behavior of metal complexes.
3. Define Stability constant? Explain Thermodynamic and kinetic stability.
4. Explain Tautomerism of Nitro alkanes.
5. Write comparative study of Basic strength of Aniline, N-methyl aniline and N,N dimethyl aniline.
6. Define the following terms (a) Enthalpy (b) Internal energy.
7. Explain entropy changes in Spontaneous and Non –Spontaneous processes.

SECTION-B

Answer any FIVE questions. Each question carries 10 marks. 5X10=50

8. Explain VBT of coordination compounds
9. Explain Crystal field splitting Theory
10. Describe Gouy's method
11. Explain Factors affecting the stability of Metal complexes.
12. What are Nitro alkanes? write any two preparation methods and two chemical reactions.
13. What are amines? Write any four chemical reactions of amines
14. Write about Electrophilic substitution of Aromatic amines
15. Define an equation for work done of an ideal gas under isothermal and adiabatic process.

**The Guidelines to be followed by the question paper setters in chemistry for the
V- Semester - end exams**

SEMESTER – V SUBJECT: CHEMISTRY COURSE CODE: CHE-501C
PAPER TITLE : INORGANIC,ORGANIC & PHYSICAL CHEMISTRY, Paper –V
ACADEMIC YEAR-2021-2022

Weightage for the question paper

syllabus	Section-A (Short answer questions)	Section-B (essay questions)
Unit-1 (25 Marks)	1	1 + 1
Unit-2 (30 Marks)	1 + 1	1+1
Unit-3 (15 Marks)	1	1
Unit-4 (25 Marks)	1	1 + 1
Unit-5 (20Marks)	1 +1	1

- Each Short answer question carries 5 marks in Section –A
- Each Essay question carries 10 marks in Section –B
- The Question papers setters are requested to cover all the topics in the syllabus stipulated as per the weightage given by us.

**A.G. & S.G.SIDDHARTHA DEGREE COLLEGE OF ARTS & SCIENCE (AUTONOMOUS),
VUYYURU.
(Accredited at "A" Grade by NAAC, Bangalore)
PRACTICAL SYLLABUS**

Practical Paper – V Organic Qualitative Analysis	PAPER CODE : CHE-501 P ACADEMIC YEAR-2021-2022
---	---

30 hrs (2 h/W) Credits: 2

Organic Qualitative Analysis:

50M

Analysis of an organic compound through systematic qualitative procedure for functional group identification including the determination of melting point and boiling point .

Alcohols, Phenols, Aldehydes, Ketones, Carbohydrates, Carboxylic acids, Aromatic Primary Amines.

SCHEME OF VALUATION

1. INTERNAL MARKS- Record-10M
 2. EXTERNAL MARKS-40
 - Analysis of an organic compound and preparation of suitable derivative-30M
 - Viva questions = 10 M
- TOTAL = 50 M__

**A.G. & S.G.SIDDHARTHA DEGREE COLLEGE OF ARTS & SCIENCE
(AUTONOMOUS),VUYYURU.**

(Accredited at “A” Grade by NAAC, Bangalore)

SEMESTER – V	Paper – VI	SUBJECT: CHEMISTRY	PAPER CODE: CHE-
502C			
PAPER TITLE : INORGANIC,ORGANIC & PHYSICAL CHEMISTRY			
ACADEMIC YEAR-2021-2022			

60 hrs (4h/w) Credits-3

INORGANIC CHEMISTRY

UNIT-I

1. Reactivity of metal complexes: (10+5) 5h

Labile and inert complexes, ligand substitution reactions - SN^1 and SN^2 , substitution reactions of square planar complexes - Trans effect and applications of Trans effect.

2. Bio inorganic chemistry: (10) 5h

Essential elements, biological significance of Na, K, Mg, Ca, Fe, Co, Ni, Cu, Zn and Cl. Metallo porphyrins – Structure and functions of hemoglobin, Myoglobin and Chlorophyll.

ORGANIC CHEMISTRY

UNIT- II

Heterocyclic Compounds (10+5) 10h

Introduction and definition: Simple five membered ring compounds with one hetero atom Ex. Furan. Thiophene and pyrrole - Aromatic character – Preparation from 1,4,-dicarbonyl compounds, Paul-Knorr synthesis. Properties: Acidic character of pyrrole - electrophilic substitution at 2 or 5 position, Halogenation, Nitration and Sulphonation under mild conditions - Diels Alder reaction in furan. Pyridine – Structure - Basicity - Aromaticity - Comparison with pyrrole - one method of preparation and properties - Reactivity towards Nucleophilic substitution reaction.

UNIT-III

Carbohydrates (10+5+5+5)

12h

Monosaccharide's: Glucose (aldo hexose) - Evidence for cyclic structure of glucose (some negative aldehydes tests and mutarotation) - Proof for the ring size (methylation, hydrolysis and oxidation reactions) - Pyranose structure (Haworth formula and chair conformational formula).

Fructose (keto hexose) - Evidence of 2 - keto hexose structure (formation of pent acetate, formation of cyanohydrin its hydrolysis and reduction by HI). Cyclic structure for fructose (Furanose structure and Haworth formula) - osazone formation from glucose and fructose – Definition of anomers with examples.

Interconversion of Monosaccharide's: Aldopentose to Aldohexose (Arabinose to D- Glucose, D-Mannose) (Kiliani - Fischer method). Epimers, Epimerisation - Lobry de bruyn van Ekenstein rearrangement. Aldohexose to Aldopentose (D-Glucose to D- Arabinose) by Ruff degradation. Aldohexose to Ketohexose [(+) Glucose to (-) Fructose] and Ketohexose to Aldohexose (Fructose to Glucose)

UNIT- IV

Amino acids and proteins (10+10+5)

12h

Introduction: Definition of Amino acids, classification of Amino acids into alpha, beta, and gamma amino acids. Natural and essential amino acids - definition and examples, classification of alpha amino acids into acidic, basic and neutral amino acids with examples. Methods of synthesis: General methods of synthesis of alpha amino acids (specific examples - Glycine, Alanine, valine and leucine) by following methods: a) from halogenated carboxylic acid b) Malonic ester synthesis c) strecker's synthesis.

Physical properties: Zwitter ion structure - salt like character - solubility, melting points, amphoteric character, definition of isoelectric point.

Chemical properties: General reactions due to amino and carboxyl groups-lactams from gamma and delta amino acids by heating peptide bond (amide linkage). Structure and nomenclature of peptides and proteins.

Mass Spectrometry: (10M)

6h

Basic principles-Molecular ion/parent ion, fragment ions/daughter ions. Theory-formation of parent ions. Representation of mass spectrum. Identification of parent ion, (M+1),(M+2), base

peaks(relative abundance 100%) Determination of molecular formula-mass spectra of ethyl benzene, acetophenone,1-propanol.

PHYSICAL CHEMISTRY

UNIT-V

1. Chemical kinetics (10+5)

10h

Rate of reaction - Definition of order and molecularity. Derivation of rate constants for first, second, third and zero order reactions and examples. Derivation for time half change. Methods to determine the order of reactions. Effect of temperature on rate of reaction, Arrhenius equation, concept of activation energy.

List of Reference Books

1. Concise coordination chemistry by Gopalan and Ramalingam
2. Coordination Chemistry by Basalo and Johnson
3. Organic Chemistry by G.Mare loudan, Purdue Univ
4. Advanced Physical Chemistry by Atkins
5. Text book of physical chemistry by S Glasstone

**A.G. & S.G.SIDDHARTHA DEGREE COLLEGE OF ARTS & SCIENCE
(AUTONOMOUS), VUYYURU.**

(Accredited at "A" Grade by NAAC, Bangalore)

SEMESTER – V	PAPER-VI	PAPER CODE : CHE-502C
PAPER TITLE : INORGANIC,ORGANIC & PHYSICAL CHEMISTRY		
ACADEMIC YEAR-2021-2022		

Time: 3Hours

Maximum marks: 70

Minimum marks: 28

SECTION-A

Answer any FOUR of the following. Each question carries 5 marks.

4X5=20

1. Explain labile and inert complex with suitable examples.
2. Explain the aromatic character of pyrrole.
3. Write the classification of Carbohydrates with suitable examples
4. How do you convert Ketohexose to Aldohexose.
5. Write a note on Ruff's degradation of an Aldohexose.
6. Write the preparation of lactams from gamma and delta amino acids
7. What is Zero order reaction? give examples

SECTION-B

Answer any FIVE questions. Each question carries 10 marks. 5X10=50

8. Explain uni molecular and bi molecular nucleophilic substitution reactions and write mechanism of nucleophilic substitution in square planar complexes.
9. Explain the role of Fe, Co, Zn in biological systems.
10. What are Hetero cyclic compounds? Write the preparation and properties of Furan.
11. Explain the structure of Fructose.
12. What are amino acids and proteins? Give two methods of preparation of α -amino acids with equations.
13. Give reactions to show the presence of NH_2 and COOH groups in α -amino acids.
14. Write the principles of Mass spectrometry.
15. Define order of the reaction. Explain any three methods for the determination of the order of the reaction

**The Guidelines to be followed by the question paper setters in chemistry for the
V- Semester - end exams**

SEMESTER – V	SUBJECT: CHEMISTRY	PAPER CODE: CHE-502C
PAPER TITLE : INORGANIC,ORGANIC & PHYSICAL CHEMISTRY, Paper – VI		
ACADEMIC YEAR-2021-2022		

Weightage for the question paper

syllabus	Section-A (Short answer questions)	Section-B (essay questions)
Unit-1 (25 Marks)	1	1 + 1
Unit-2 (15 Marks)	1	1
Unit-3 (25 Marks)	1 + 1+1	1
Unit-4 (35 Marks)	1	1 + 1 +1
Unit-5 (15 Marks)	1	1

- Each Short answer question carries 5 marks in Section –A
- Each Essay question carries 10 marks in Section –B
- The Question papers setters are requested to cover all the topics in the syllabus stipulated as per the weightage given by us.

**A.G. & S.G.SIDDHARTHA DEGREE COLLEGE OF ARTS & SCIENCE (AUTONOMOUS),
VUYYURU.**

(Accredited at "A" Grade by NAAC, Bangalore)

PRACTICAL SYLLABUS

Practical Paper –VI Physical Chemistry	COURSE CODE : CHE-502 P ACADEMIC YEAR-2021-2022
---	--

30 hrs (2 h/W) Credits: 2

1. Determination of rate constant for acid catalyzed ester hydrolysis.
2. Determination of molecular status and partition coefficient of benzoic acid in Benzene and water.
3. Determination of Surface tension of liquid
4. Determination of Viscosity of liquid.
5. Adsorption of oxalic acid on silica gel, verification of Freundlich isotherm.

SCHEME OF VALUATION

2. INTERNAL MARKS- Record-10M

2. EXTERNAL MARKS-40

- Practical-30M
- Viva questions = 10 M

TOTAL = 50 M__

**A.G& S.G.SIDDHARTHA DEGREE COLLEGE OF ARTS &
SCIENCE**

VUYYURU-521165, KRISHNA Dt., A.P.(Autonomous)

Accredited by NAAC with "A" Grade

2021-2022



DEPARTMENT OF CHEMISTRY

MINUTES OF BOARD OF STUDIES

EVEN SEMESTER

06-04-2022

Minutes of the Meeting of Board of Studies in Chemistry for the Autonomous Course

A.G. & S.G.Siddhartha Degree College of Arts & Science, Vuyyuru held at 11.00 A.M on 06-04--2022 in

the Department of Chemistry.

Sri. K.RAMESH

Presiding

Members Present:

- 1) K. Ramesh Chairman HOD, Dept. of Chemistry,
(Sri. K.RAMESH) A.G. & S.G.S.Degree College, Vuyyuru.
- 2) D. Ramasekhara Reddy University Nominee Assistant Professor,
(Prof.D.Ramasekhara Reddy) Dept. of Chemistry, Krishna University, MTM.
- 3) S. Kalpana Academic Council Nominee HOD, Dept. of Chemistry,
(Dr. S. Kalpana) SDMS M College, Vijayawada.
- 4) A. Indira Academic Council Nominee Lecturer in Chemistry,
(Smt. A. Indira) G.D.C, Dumpagadapa
- 5) Industrialist Manager, Q.A, Biophore india
(Dr. G Raja) Pharmaceuticals pvt ltd Hyd,
- 6) Student Nominee Lecturer in Chemistry,
(Smt. M. Sowjanya) ANR College Gudivada.
- 7) G. Giri Prasad Member Lecturer in Chemistry,
(Dr. G.Giri prasad) A.G. & S.G.S.Degree College, Vuyyuru
- 8) M. Venkatesh Member Lecturer in Chemistry,
(Smt. M.V.Santhi) A.G. & S.G.S.Degree College, Vuyyuru.
- 9) P. Suresh Member Lecturer in Chemistry,
(Sri. P.Suresh) A.G. & S.G.S.Degree College, Vuyyuru.
- 10) M. Santhi Member Lecturer in Chemistry,
(MS. M.Santhi) A.G. & S.G.S.Degree College, Vuyyuru.
- 11) J. Nageswara Rao Member Rtd.Lecturer in Chemistry,
(Sri. J.Nageswara Rao) A.G. & S.G.S.Degree College, Vuyyuru.

Agenda for B.O.S Meeting

1. To recommend the syllabus and model paper for II semester of I Degree B.Sc., Chemistry for the Academic year 2021-2022.
2. To recommend the syllabus and model papers for IV semester of II Degree B.Sc., Chemistry for the Academic year 2021-2022.
3. To recommend the syllabus and model papers for VI semester of III Degree B.Sc. Chemistry for the Academic year 2021-2022.
4. To recommend the Blue print of II, IV, VI semesters of B.Sc. Chemistry for the Academic year 2021--2022.
5. To recommend the Guidelines to be followed by the question paper setters in Chemistry for II, IV, VI Semester-end exams.
6. To recommend the teaching and evaluation methods to be followed under Autonomous status.
7. Any suggestions regarding certificate course, seminars, workshops, Guest lecture to be organized.
8. Recommend the panel of paper setters and Examiners to the controller of Examinations of autonomous Courses of A.G. & S.G.S. Degree colleges of Arts & Science, Vuyyuru.
9. Any other matter.

K. Ramallu
Chairman.

RESOLUTIONS

- 1) It is resolved to Change the **syllabus for II semesters of I B.Sc.** under Choice Based Credit System (CBCS) for the Academic year 2021--2022.
Adding Syllabus: HSAB Unit-4
- 2) It is resolved to follow the **syllabus of APSCHE for IV semesters of II B.Sc.** under Choice Based Credit System (CBCS) for the Academic year 2021--2022. II, IV, & VI
 - In this academic year two papers will be introduced i.e. CHE-401(Inorganic, Organic and Physical chemistry) & CHE-402(Inorganic, Organic and Physical chemistry)
- 3) It is resolved to implement the same **syllabus** under Choice Based Credit System for the Academic year 2021-2022 for **VI semester of III B.Sc.**
- 4) It is resolved to follow the **Blue prints** as proposed by members of BOS II, IV & VI semester of Degree B.Sc. for the Academic year 2021-2022.
- 5) It is resolved to follow the **guidelines** to be followed by the question paper setters of Chemistry for II, IV & VI semesters of Degree B.Sc. for the Academic Year 2021-2022.
- 6) It is resolved to continue the following teaching and evolution methods for Academic year 2021-22.

Teaching Methods:

Besides the conventional methods of teaching, we use modern technology i.e. using of LCD projector to display on U boards etc, for better understanding of concepts.

Evaluation of a student is done by the following procedure:

• Internal Assessment Examinations:

- Out of maximum 100 marks in each paper for I B.Sc, 25 marks shall be allocated for internal assessment. Out of these 25 marks, 15 marks are allocated for announced tests (i.e. IA-1 & IA-2).
- Out of maximum 100 marks in each paper for II, III B.Sc, 30 marks shall be allocated for internal assessment. Out of these 30 marks, **20 marks are allocated for announced tests (i.e. IA-1 & IA-2).**
- Two announced tests will be conducted and average of these two tests shall be deemed as the marks obtained by the student, **5 marks** are allocated on the basis of candidate's **percentage of attendance and remaining 5 marks are allocated for the innovative component like assignment/quiz/seminars for II, IV, VI B.Sc.**
- There is **no pass minimum** for internal assessment for I, II, III B.Sc.

Semester – End Examination:

- The maximum marks for I B.Sc Semester – End examination shall be 75 marks and 70 marks for II, III B.Sc., duration of the examination shall be 3 hours. Even though the candidate is absent for two IA exams /obtain Zero marks the external marks are considered (if the candidate gets 40/70) and the result shall be declared as "PASS".
- Semester – End examinations shall be conducted in theory papers at the end of every semester, while in practical papers, these examinations are conducted at the end of II, IV, & VI semesters for I, II & III B.Sc for 50 marks.
- Discussed and recommended for organizing **certificate course, seminars, Guest lecturers, workshops** to upgrade the knowledge of students, for the approval of the academic council.
- Discussed and empowered the Head of the department of Chemistry to suggest the panel of paper setters and examiners to the controller of examinations.
- NIL.

K. Ramani

Chairman



**A.G & S.G. SIDDHARTHA DEGREE COLLEGE OF
ARTS & SCIENCE**

Vuyyuru-521165

NAAC recredited at "A" level

Autonomous -ISO 9001 – 2015 Certified

Title of the Paper: ORGANIC AND GENERAL CHEMISTRY

Semester: II

Course Code	CHET21A	Course Delivery Method	Class Room / Blended Mode
Credits	3	CIA Marks	25
No. of Lecture Hours / Week	4	Semester End Exam Marks	75
Total Number of Lecture Hours	60	Total Marks	100
Year of Introduction : 2021-22	Year of Offering: 2021 - 22	Year of Revision: -----	Percentage of Revision: 0

Course outcomes:

At the end of the course, the student will be able to;

CO1. Understand and explain the differential behaviour of organic compounds based on fundamental concepts learnt.

CO2. Formulate the mechanism of organic reactions by recalling and correlating the fundamental properties of the reactants involved.

CO3. Learn and identify many organic reaction mechanisms including Free Radical Substitution, Electrophilic Addition and Electrophilic Aromatic Substitution.

CO4. Understand the concepts of absorption and adsorption, colloidal chemistry and nature of Chemical Bonding.

CO5. Correlate and describe the stereo chemical properties of organic compounds and reactions.

Learning Objectives:

1. To understand the basic concepts of alkanes & cycloalkanes.
2. To identify the difference between saturated and unsaturated hydrocarbons.
3. To learn the basic concepts of aromatic compounds and its reactivity.
4. To understand the chemistry of adsorption, colloid chemistry, HSAB principle and Molecular Orbital theory.
5. To learn the fundamental aspects of stereo chemistry.

Syllabus

Course Details

Unit	Learning Units	Lecture Hours
ORGANIC CHEMISTRY		
I	<p>Recapitulation of Basics of Organic Chemistry Carbon-Carbon sigma bonds (Alkanes and Cycloalkanes)</p> <p>1.1 General methods of preparation of alkanes- Wurtz and Wurtz - Fittig reaction, Corey House synthesis, physical and chemical properties of alkanes, Isomerism and its effect on properties.</p> <p>1.2 Free radical substitutions; Halogenation, concept of relative reactivity v/s selectivity.</p> <p>1.3 Conformational analysis of alkanes (Conformations, relative stability and energy diagrams of Ethane, Propane and butane).</p> <p>1.4 General molecular formulae of cycloalkanes and relative stability, Baeyer strain theory, Cyclohexane conformations with energy diagram, Conformations of mono substituted cyclohexane.</p>	12h
II	<p>Carbon-Carbon pi Bonds (Alkenes and Alkynes)</p> <p>2.1 General methods of preparation, physical and chemical properties.</p> <p>2.2 Mechanism of E1, E2, E1CB reactions, Saytzeff and Hoffmann eliminations, Electrophilic Additions, mechanism (Markownikoff / Antimarkownikoff addition) with suitable examples, <i>syn</i> and <i>anti</i>-addition; addition of H₂, X₂, HX. oxymercuration-9, demercuration, hydroboration-oxidation, ozonolysis, Hydroxylation, Diels alder reaction, 1,2 and 1,4 addition reaction in Conjugated Dienes.</p> <p>2.3 Reactions of alkynes; acidity, electrophilic and</p>	12h

	nucleophilic additions, hydration to form carbonyl compounds, Alkylation of terminal alkynes.	
III	<p>Benzene and its reactivity</p> <p>3.1 Concept of aromaticity, Huckel's rule - application to Benzenoid (Benzene, Naphthalene) and Non - Benzenoid compounds (cyclopropenylcation, cyclopentadienyl anion and tropyliumcation)</p> <p>3.2 Reactions - General mechanism of electrophilic aromatic substitution, mechanism of nitration, Friedel-Craft's alkylation and acylation.</p> <p>3.3 Orientation of aromatic substitution - ortho, para and meta directing groups. Ring activating and deactivating groups with examples (Electronic interpretation of various groups like NO₂ and Phenolic). Orientation of (i) Amino, methoxy and methyl groups (ii) Carboxy, nitro, nitrile, carbonyl and sulphonic acid groups (iii) Halogens (Explanation by taking minimum of one example from each type)</p>	12h
GENERAL CHEMISTRY		
IV	<p>Surface chemistry and chemical bonding</p> <p>1. Surface chemistry</p> <p>4.1 Colloids- Coagulation of colloids- Hardy-Schulze rule. Stability of colloids, Protection of Colloids, Gold number.</p> <p>4.2 Adsorption-Physical and chemical adsorption, Langmuir adsorption isotherm, applications of adsorption.</p> <p>2. Chemical Bonding</p> <p>4.3 Valence bond theory, hybridization, VB theory as applied to ClF₃, Ni(CO)₄</p>	14h

	<p>4.4 Molecular orbital theory -LCAO method, construction of M.O. diagrams for homo-nuclear and hetero-nuclear diatomic molecules (N₂, O₂, CO and NO).</p> <p>3. HSAB</p> <p>4.5 Pearson's concept, HSAB principle & its importance, bonding in Hard-Hard and Soft-Soft combinations.</p>	
V	<p>Stereochemistry of carbon compounds</p> <p>5.1 Molecular representations- Wedge, Fischer, Newman and Saw-Horse formulae.</p> <p>5.2 Optical isomerism: Optical activity- wave nature of light, plane polarised light, optical rotation and specific rotation.</p> <p>5.3 Chiral molecules- definition and criteria(Symmetry elements)- Definition of enantiomers and diastereomers – Explanation of optical isomerism with examples- Glyceraldehyde, Lactic acid, Alanine, Tartaric acid, 2,3-dibromopentane.</p> <p>5.4 D, L, R,S and E,Z- configuration with examples. Definition of Racemic mixture – Resolution of racemic mixtures (any 3 techniques)</p>	10h

Co-curricular activities and Assessment Methods

Continuous Evaluation: Monitoring the progress of student's learning

Class Tests, Worksheets and Quizzes

Presentations, Projects and Assignments and Group Discussions: Enhances critical thinking skills and personality

Semester-end Examination: critical indicator of student's learning and teaching methods adopted by teachers throughout the semester.

List of Text Books

1. A Text book of Organic Chemistry by Lloyd.N.Ferguson
2. A Text book of Organic Chemistry by Rakesh K.Parashar & V.K.Ahluwalia
3. Telugu Academy Book
4. Unified Chemistry by O.P.Agarwal-Vol-I

List of Reference Books

Theory:

1. Morrison, R. N. & Boyd, R. N. Organic Chemistry, Dorling Kindersley (India) Pvt. Ltd. (Pearson Education).
2. Finar, I. L. Organic Chemistry (Volume 1), Dorling Kindersley (India) Pvt. Ltd. (Pearson Education).
3. Finar, I. L. Organic Chemistry (Volume 2: Stereochemistry and the Chemistry of Natural Products), Dorling Kindersley (India) Pvt. Ltd. (Pearson Education).
4. Eliel, E. L. & Wilen, S. H. Stereochemistry of Organic Compounds; Wiley: London, 1994.
5. Kalsi, P. S. Stereochemistry Conformation and Mechanism; New Age International, 2005.

Practical:

1. Ahluwalia, V.K. & Aggarwal, R. Comprehensive Practical Organic Chemistry: Preparation and Quantitative Analysis, University Press (2000).
2. Ahluwalia, V.K. & Dhingra, S. Comprehensive Practical Organic Chemistry: Qualitative Analysis, University Press (2000).
3. Furniss, B.S.; Hannaford, A.J.; Smith, P.W.G.; Tatchell, A.R. Practical Organic Chemistry, 5th Ed., Pearson (2012)

Additional Resources:

1. Solomons, T. W. G.; Fryhle, C. B. & Snyder, S. A. Organic Chemistry, 12th Edition, Wiley. Bruice, P. Y. Organic Chemistry, Eighth Edition, Pearson.
2. Clayden, J.; Greeves, N. & Warren, S. Organic Chemistry, Oxford.
3. Nasipuri, D. Stereochemistry of Organic Compounds: Principles and Applications, Third Edition, New Age International.
4. Gunstone, F. D. Guidebook to Stereochemistry, Prentice Hall Press, 1975.

**A.G. & S.G.SIDDHARTHA DEGREE COLLEGE OF ARTS & SCIENCE
(AUTONOMOUS), VUYYURU.**

SEMESTER – II	PAPER-II	PAPER CODE : CHET21A
PAPER TITLE: ORGANIC & GENERAL CHEMISTRY -I		
ACADEMIC YEAR-2021-2022		

Time: 3 Hours

Max. Marks: 75M

PART- A

5 X 5 = 25 Marks

Answer any **FIVE** of the following questions. Each carries **FIVE** marks

1. Write different conformations of n-butane. Explain their relative stability. **L2- CO1**
2. Explain 1, 2- & 1,4- addition reactions of conjugated dienes. **L2- CO2**
3. Explain the orientation effect of halogens on mono substituted benzene. **L2- CO3**
4. Explain the mechanism of E₁CB elimination reaction. **L2- CO2**
5. Explain the structure of ClF₃ by Valency Bond theory. **L2- CO4**
6. What are Hard & soft acids & bases? Explain with examples. **L1- CO4**
7. Draw the Wedge, Fischer, Newmann & saw-Horse representations for Tartaric acid. **L1- CO5**
8. Define Enantiomers and Diastereomers and give two examples for each. **L2- CO5**

PART- B

5 X 10 = 50 Marks

Answer **ALL** the questions. Each carries **TEN** marks

9. (a) (i) Write the preparation of alkanes by Wurtz and Corey-House reaction.
(ii) Explain Halogenation of alkanes. Explain the reactivity and selectivity in free radical substitutions. **L2- CO1**
(or)
(b). (i) Explain Baeyer Strain Theory
(ii) Draw the conformations of Cyclohexane and explain their stability by drawing energy profile diagram. **L2- CO1**
10. (a). (i) Write any two methods of preparation of alkenes.
(ii) Explain the mechanism of Markownikoff and Anti-Markownikoff addition of HBr to alkene. **L2- CO2**
(or)
(b) (i) Explain the acidity of 1-alkynes
(ii) How will you prepare acetaldehyde and acetone from alkynes?
(iii) Write alkylation reaction of terminal alkyne. **L1- CO2**

11. (a) Define Huckel rule of aromatic compounds. What are Benzenoid and non-Benzenoid aromatic compounds? Give examples. **L1- CO3**

(or)

(b) Explain the mechanisms of Nitration and Friedel-Craft's alkylation of Benzene. **L2- CO3**

12. (a) (i) Define Hardy-Schulze rule & Gold number.

(ii) Differentiate Physisorption & Chemisorption. Explain Langmuir adsorption isotherm.

L2- CO4

(or)

(b) Construct the Molecular Orbital diagram for O₂ and NO and explain their bond order and magnetic property. **L2- CO4**

13. (a) Define racemic mixture. Explain any two techniques for resolution of racemic mixture. **L2- CO5**

(or)

(b) (i) Define Optical activity and Specific rotation.

(ii) Draw the R- & S- isomers of Alanine, Glyceraldehyde.

(iii) Write the E- & Z- isomers of 2-butene. **L1- CO5**

**A.G.&S.G.SIDDHARTHA DEGREE COLLEGE OF ARTS & SCIENCE
(AUTONOMOUS), VUYYURU.
(Accredited at “A” Grade by NAAC, Bangalore)
PRACTICAL SYLLABUS.**

Practical Paper – II Volumetric Analysis	PAPER CODE : CHEP21A ACADEMIC YEAR-2021-2022
---	---

30 hrs (2h/w)

Credits-2

Course outcomes:

At the end of the course, the student will be able to;

1. Use glassware, equipment and chemicals and follow experimental procedures in the laboratory
2. Understand and explain the volumetric analysis based on fundamental concepts learnt in ionic Equilibria
3. Learn and identify the concepts of standard solutions, primary and secondary standards
4. Facilitate the learner to make solutions of various molar concentrations. This may include: The concept of the mole; Converting moles to grams; Converting grams to moles; Defining concentration; Dilution of Solutions; Making different molar concentrations.

Volumetric analysis 50 M

1. Estimation of sodium carbonate and sodium hydrogen carbonate present in a mixture.
2. Determination of Fe (II) using KMnO_4 with oxalic acid as primary standard.
3. Determination of Cu (II) using $\text{Na}_2\text{S}_2\text{O}_3$ with $\text{K}_2\text{Cr}_2\text{O}_7$ as primary standard
4. Estimation of water of crystallization in Mohr's salt by titrating with KMnO_4



A.G & S.G. SIDDHARTHA DEGREE COLLEGE OF ARTS & SCIENCE

Vuyyuru-521165

NAAC recredited at "A" level

Autonomous -ISO 9001 – 2015 Certified

Title of the Paper: INORGANIC, ORGANIC AND PHYSICAL CHEMISTRY

Semester: IV

Course Code	CHE-401C	Course Delivery Method	Class Room / Blended Mode
Credits	3	CIA Marks	30
No. of Lecture Hours / Week	4	Semester End Exam Marks	70
Total Number of Lecture Hours	60	Total Marks	100
Year of Introduction : 2021 - 22	Year of Offering: 2021 - 22	Year of Revision: -----	Percentage of Revision: 0

Program outcomes:

Main objectives of this paper is to give a basics, applications and updated knowledge for the students on Chemistry of Organometallic Compounds, Carbohydrates Amino acids and proteins, Nitrogen Containing Functional Groups, Photochemistry and Thermodynamics.

Course Outcomes:

At the end of the course, the student will be able to:

1. To learn about the laws of absorption of light energy by molecules and the subsequent photochemical reactions.
2. To understand the concept of quantum efficiency and mechanisms of photochemical reactions

Syllabus

Course Details

Unit	Learning Units	Lecture Hours
INORGANIC CHEMISTRY		
I	<p>Organometallic Compounds (Marks weightage 10+5)</p> <p>Definition and classification of organometallic Compounds on the basis of bond type, Concept of hapticity of organic ligands. Metal carbonyls: 18electronrule, electron count of mononuclear, poly nuclear and substituted metal carbonyls of Fe, Ni, Co.</p>	8h
ORGANIC CHEMISTRY		
II	<p>Carbohydrates (Marks weightage 10)</p> <p>Occurrence, classification, Monosaccharides: Constitution and absolute configuration of glucose and fructose, epimers and anomers, mutarotation, determination of ring size of glucose and fructose, Haworth projections and conformational structures;</p> <p>Interconversions (Marks weightage 5)</p> <p>1. Aldopentose to Aldohexose (Killiani-Fischer synthesis) 2. Aldohexose to Aldopentose (Ruff degradation). 3. Aldohexose to ketohexose 4. Ketohexose to Aldohexose</p>	8h
III	<p>1. Amino acids and proteins (Marks weightage 10)</p> <p>6h</p> <p>Introduction: Definition of Amino acids, classification of Amino acids into alpha, beta, and gamma amino acids. Natural and essential amino acids - definition and examples, classification of alpha amino acids into acidic, basic and neutral amino acids with examples. Methods of synthesis: General methods of synthesis of alpha amino acids (specific examples - Glycine, Alanine, valine and leucine) by following methods: a) from halogenated carboxylic acid b) from malonic ester synthesis c) strecker's synthesis.</p>	6h

	<p>Physical properties: (Marks weightage 5) Zwitter ion structure - salt like character - solubility, melting points, amphoteric character, definition of isoelectric point.</p> <p>Chemical properties: (Marks weightage 5) General reactions due to amino and carboxyl groups - lactams from gamma and delta amino acids by heating- peptide bond (amide linkage). Structure and nomenclature of peptides and proteins.</p> <p>2. Heterocyclic Compounds (Marks weightage 10) Introduction and definition: Simple five membered ring compounds with one hetero atom Ex. Furan. Thiophene and pyrrole - Aromatic character – Preparation from 1, 4, -dicarbonyl compounds, Paul-Knorr synthesis. Properties: Acidic character of pyrrole - electrophilic substitution at 2 or 5 position, Halogenation, Nitration and Sulphonation under mild conditions - Diels Alder reaction in furan.</p> <p>Pyridine (Marks weightage 5) Pyridine – Structure - Basicity - Aromaticity- Comparison with pyrrole- one method of preparation and properties - Reactivity towards Nucleophilic substitution reaction</p>	7h
IV	<p>Nitrogen Containing Functional Groups Preparation, properties and important reactions of nitro compounds, amines and diazonium salts.</p> <p>1. Nitrohydrocarbons 3h</p> <p>Nomenclature and classification-nitro hydrocarbons, structure - Tautomerism of nitroalkanes leading to aci and keto form, Preparation of Nitroalkanes, reactivity -halogenation, reaction with HONO (Nitrous acid),</p> <p>Reactions (Marks weightage 10) Nef reaction and Mannich reaction leading to Micheal addition</p>	3h

	<p>and reduction.</p> <p>2. Amines (Marks weightage 10 +5)</p> <p>Introduction, classification, chirality in amines (pyramidal inversion), importance and general methods of preparation.</p> <p>Properties : Physical properties, Basicity of amines: Effect of substituent, solvent and steric effects. Distinction between Primary, Secondary and tertiary amines using nitrous acid.</p> <p>Discussion of the following reactions; (Not required mechanism) Gabriel Phthalimide synthesis, Hoffmann-Bromamide reaction, Carbylamine reaction.</p> <p>Diazonium Salts:</p> <p>Synthetic applications of diazonium salts including preparation of arenes, haloarenes, Coupling reactions of diazonium salts (preparation of azo dyes).</p>	11h
V	<p>1.Photochemistry (Marks weightage 10+5)</p> <p>Difference between thermal and photochemical processes, Laws of photochemistry- Grothus- Draper's law and Stark-Einstein's law of photochemical equivalence, Quantum yield- Photochemical reaction mechanism- hydrogen- chlorine and hydrogen- bromine reaction. Qualitative description of fluorescence, phosphorescence, Jablonski diagram, Photosensitized reactions- energy transfer processes (simple example).</p> <p>2. Thermodynamics (Marks weightage 10+5)</p> <p>The first law of thermodynamics-statement, definition of internal energy and enthalpy, Heat capacities and their relationship, Joule-Thomson effect- coefficient, Calculation of work for the expansion of perfect gas under isothermal and adiabatic conditions for reversible processes, State function. Temperature dependence of enthalpy of formation- Kirchoff s equation, Second law of thermodynamics Different Statements of the law,</p>	5h

Carnot cycle and its efficiency, Carnot theorem, Concept of entropy, entropy as a state function, entropy changes in reversible and irreversible processes.	12h
---	------------

List of Reference Books

1. Concise coordination chemistry by Gopalan and Ramalingam
2. Coordination Chemistry by Basalo and Johnson
3. Organic Chemistry by G.Mareloudan, Purdue Univ
4. Text book of physical chemistry by S Glasstone
5. Concise Inorganic Chemistry by J.D.Lee
6. Advanced Inorganic Chemistry Vol-I by Satyaprakash, Tuli, Basu and Madan
7. A Text Book of Organic Chemistry by Bahl and Arunbahl
8. A Text Book of Organic chemistry by I L FinarVol I
9. A Text Book of Organic chemistry by I L FinarVol II
10. Advanced physical chemistry by Gurudeep Raj

**A.G. & S.G.SIDDHARTHA DEGREE COLLEGE OF ARTS & SCIENCE
(AUTONOMOUS), VUYYURU.**

SEMESTER – IV IV	PAPER-	PAPER CODE : CHE-401C
PAPER TITLE: INORGANIC, ORGANIC & PHYSICAL CHEMISTRY ACADEMIC YEAR-2021-2022		

Time: 3 hours

Maximum Marks: 70

PART- A

4 X 5 = 20 Marks

Answer any **FOUR** of the following questions. Each carries **FIVE** marks

1. Describe the 18 electron rule of mono nuclear and polynuclear metal carbonyls with suitable examples.
2. What are epimers and anomers. Give examples.
3. Discuss about isoelectric point.
4. Write the reactions due to amino group.
5. Discuss the structure of pyridine.
6. Discuss the basic nature of amines.
7. Write the differences between thermal and photochemical reactions.
8. Derive heat capacities and derive $C_p - C_v = R$.

PART- B

Answer any FIVE questions. Each question carries 10 marks.

5X10=50M

9. What are organometallic compounds? Discuss their Classification on the basis of type of bonds with examples.
10. Discuss the structure illustration of fructose.
11. What are amino acids? Write any two general methods of preparation of amino acids.
12. Discuss the aromatic character of Furan, Thiophene and Pyrrole.
13. Write the mechanism for the following. (i). Nef reaction (ii) Mannich reaction
14. Discuss any three synthetic applications of diazonium salts
15. Explain about Jablonski diagram.
16. Define entropy. Describe entropy changes in the reversible and irreversible process.

The Guidelines to be followed by the question paper setters in chemistry for the

IV- Semester - end exams

SEMESTER – IV SUBJECT: CHEMISTRY COURSE CODE: CHE-401C
PAPER TITLE : INORGANIC, ORGANIC AND PHYSICAL CHEMISTRY
ACADEMIC YEAR-2021-2022

Weightage for the question paper

syllabus	Section-A (Short answer questions)	Section-B (essay questions)
Unit-1 (15 Marks)	1	1
Unit-2 (15 Marks)	1	1
Unit-3 (35 Marks)	1+1+1	1+1
Unit-4 (25 Marks)	1	1+1
Unit- 5 (30 Marks)	1+1	1+1

- Each Short answer question carries 5 marks in Section –A
- Each Essay question carries 10 marks in Section –B

The Question papers setters are requested to cover all the topics in the syllabus stipulated as per the weightage given by us.

**A.G.&S.G.SIDDHARTHA DEGREE COLLEGE OF ARTS & SCIENCE
(AUTONOMOUS), VUYYURU.
(Accredited at “A” Grade by NAAC, Bangalore)
PRACTICAL SYLLABUS.**

Practical Paper – IV Organic Qualitative analysis	PAPER CODE : CHE-401 P ACADEMIC YEAR-2021-2022
--	---

30 hrs (2h/w)

Credits-2

Course outcomes:

At the end of the course, the student will be able to;

1. Use glassware, equipment and chemicals and follow experimental procedures in the laboratory.
2. Determine melting and boiling points of organic compounds
3. Understand the application of concepts of different organic reactions studied in theory part of organic chemistry.

Organic Qualitative analysis

50 M

Analysis of an organic compound through systematic qualitative procedure for functional group identification including the determination of melting point and boiling point with suitable derivatives.

Alcohols, Phenols, Aldehydes, Ketones, Carboxylic acids, Aromatic primary amines, amides and simple sugars.

SCHEME OF VALUATION

1. INTERNAL MARKS- Record-10M
 2. EXTERNAL MARKS-40
 - Analysis of an organic compound and preparation of suitable derivative-30M
 - Viva questions = 10 M
- TOTAL = 50 M_



A.G & S.G. SIDDHARTHA DEGREE COLLEGE OF

ARTS & SCIENCE

Vuyyuru-521165

NAAC recredited at "A" level

Autonomous -ISO 9001 – 2015 Certified

Title of the Paper: INORGANIC & PHYSICAL CHEMISTRY

Semester: IV

Course Code	CHE-402C	Course Delivery Method	Class Room / Blended Mode
Credits	3	CIA Marks	30
No. of Lecture Hours / Week	4	Semester End Exam Marks	70
Total Number of Lecture Hours	60	Total Marks	100
Year of Introduction : 2021 - 22	Year of Offering: 2021 - 22	Year of Revision: -----	Percentage of Revision: 0

Program outcomes:

Main objectives of this paper is to give a basics, applications and updated knowledge for the students on Chemistry of Coordination Chemistry, Inorganic Reaction Mechanism Stability of metal complexes, Bioinorganic Chemistry, Phase rule, Chemical Kinetics and Electrochemistry.

Course outcomes:

At the end of the course, the student will be able to;

1. Understand concepts of boundary conditions and quantization, probability distribution, most probable values, uncertainty and expectation value
2. Application of quantization to spectroscopy.

3. Various types of spectra and their use in structure determination.

Syllabus

Course Details

Unit	Learning Units	Lecture Hours
INORGANIC CHEMISTRY		26h
I	<p>Coordination Chemistry (Marks weightage 10+10+5) IUPAC nomenclature of coordination compounds, Structural and stereoisomerism in complexes with coordination numbers 4 and 6. Valence Bond Theory (VBT): Inner and outer orbital complexes. Limitations of VBT, Crystal field effect, octahedral symmetry. Crystal field stabilization energy (CFSE), Crystal field effects for weak and strong fields. Tetrahedral symmetry, Factors affecting the magnitude of crystal field splitting energy, Spectro chemical series,</p>	12h
II	<p>1. Inorganic Reaction Mechanism (Marks weightage 10+5) 4h Labile and inert complexes, ligand substitution reactions SN^1 and SN^2, Substitution reactions in square planar complexes, Trans-effect, theories of trans effect and its applications</p>	4h
	<p>2. Stability of metal complexes (Marks weightage 10+5) Thermodynamic stability and kinetic stability, factors affecting the stability of metal complexes, chelate effect, determination of composition of complex by Job's method and mole ratio method.</p>	8h
	<p>3. Bioinorganic Chemistry (Marks weightage 5+5) Metal ions present in biological systems, Importance of sodium, potassium and magnesium. Structure and functions of Hemoglobin.</p>	2h
PHYSICAL CHEMISTRY		34h
III	<p>1 .Phase rule (Marks weightage 10+5) Concept of phase, components, degrees of freedom. Phase diagram of one component system - water system, Study of Phase diagrams of Simple eutectic systems i) Pb-Ag system, desilverisation of lead Definition and</p>	6h

	examples for systems having congruent and incongruent melting point , freezing mixtures.	
IV	<p>Electrochemistry (Marks weightage 10+5)</p> <p>Specific conductance, equivalent conductance and molar conductance- Definition and effect of dilution. Cell constant. Strong and weak electrolytes, Kohlrausch's law and its applications, Definition of transport number, determination of transport number by Hittorf's method. Debye-Huckel-Onsagar's equation for strong electrolytes (elementary treatment only), Application of conductivity measurements- conductometric titrations. Electrochemical Cells- Single electrode potential, Types of electrodes with examples: Metal- metal ion, Gas electrode, Inert electrode, Redox electrode, Metal-metal insoluble salt- salt anion. Determination of EMF of a cell, Nernst equation, Applications of EMF measurements - Potentiometric titrations.</p>	14h
V	<p>Chemical Kinetics: (Marks weightage 10+10+5)</p> <p>The concept of reaction rates. Effect of temperature, pressure, catalyst and other factors on reaction rates. Order and molecularity of a reaction, Derivation of integrated rate equations for zero, first and second order reactions (both for equal and unequal concentrations of reactants). Half-life of a reaction. General methods for determination of order of a reaction. Concept of activation energy and its calculation from Arrhenius equation.</p>	14 h

List of Reference Books

1. Text book of physical chemistry by S Glasstone
2. Concise Inorganic Chemistry by J.D.Lee
3. Advanced Inorganic Chemistry Vol-I by Satyaprakash, Tuli, Basu and Madan
4. Advanced physical chemistry by Gurudeep Raj
5. Principles of physical chemistry by Prutton and Marron
6. Advanced physical chemistry by Bahl and Tuli
7. Inorganic Chemistry by J.E.Huheey
8. Basic Inorganic Chemistry by Cotton and Wilkinson
9. A textbook of qualitative inorganic analysis by A.I. Vogel
10. Atkins,P.W.&Paula,J.deAtkin'sPhysicalChemistryEd.,OxfordUniversityPress 10thEd(2014).
11. Castellan,G.W.Physical Chemistry 4thEd.Narosa(2004).
12. Mortimer,R. G.PhysicalChemistry 3rdEd. Elsevier:NOIDA,UP(2009).
13. Barrow,G.M.Physical Chemistry

The Guidelines to be followed by the question paper setters in chemistry for the

III- Semester - end exams

SEMESTER – IV SUBJECT: CHEMISTRY COURSE CODE: CHE-402C
PAPER TITLE : INORGANIC & PHYSICAL CHEMISTRY
ACADEMIC YEAR-2021-2022

Weightage for the question paper

syllabus	Section-A (Short answer questions)	Section-B (essay questions)
Unit-1 (25 Marks)	1	1+1
Unit-2 (40Marks)	1+1+1+1	1+1
Unit-3 (15Marks)	1	1
Unit-4 (15Marks)	1	1
Unit-5 (20Marks)	1	1+1

- Each Short answer question carries 5 marks in Section –A
- Each Essay question carries 10 marks in Section –B
- The Question papers setters are requested to cover all the topics in the syllabus stipulated as per the weightage given by us.

**A.G. & S.G.SIDDHARTHA DEGREE COLLEGE OF ARTS & SCIENCE
(AUTONOMOUS), VUYYURU.**

SEMESTER – IV	PAPER-V	PAPER CODE : CHE-402C
PAPER TITLE : INORGANIC & PHYSICAL CHEMISTRY		
ACADEMIC YEAR-2021-2022		

Time: 3 hours

Maximum Marks: 70

PART- A

4X 5 = 20 Marks

Answer any FOUR of the following questions. Each carries FIVE marks

1. Write note structural isomerism.
2. Explain Labile & inert complexes.
3. Explain mole ratio method for determination of composition of complex.
4. write structure and functions of Haemoglobin.
5. Write the importance of metals Na and K.
6. Write about freezing mixtures.
7. Explain about kohltrausch's law.
8. Explain order and molecularity.

PART- B

Answer any FIVE questions. Each question carries 10 marks.

5X10=50M

9. Explain Valence Bond theory with Inner and Outer orbital complexes. Write limitations of VBT.
10. Define CFSE. Explain the factors affecting the magnitude of crystal field splitting energy.
11. Explain Trans effect. Explain the theories of trans effect and write any two applications of trans effect.
12. Write about factors affecting the stability of metal complexes.
13. Define Phase rule and terms involved in it. Explain phase diagram of Pb-Ag system.

14. Define Transport number. Write experimental method for the determination of transport number by Hittorf method.
15. Explain general methods for determination of order of a reaction.
16. Derive second order rate equation and half-life and units.

A.G.&S.G.SIDDHARTHA DEGREE COLLEGE OF ARTS & SCIENCE (AUTONOMOUS), VUYYURU.

(Accredited at "A" Grade by NAAC, Bangalore)

PRACTICAL SYLLABUS

Practical Paper – V Conductometric and Potentiometric Titrimetry	PAPER CODE : CHE-402P ACADEMIC YEAR-2021-2022
--	--

30 hrs (2 h/W)

Credits: 2

Practical-Course –V Conductometric and Potentiometric Titrimetry

50 M

Course outcomes:

At the end of the course, the student will be able to;

1. Use glassware, equipment and chemicals and follow experimental procedures in the laboratory
2. Apply concepts of electrochemistry in experiments
3. Be familiar with electro analytical methods and techniques in analytical chemistry which study an analyte by measuring the potential (volts) and/or current (amperes) in an electrochemical cell containing the analyte

Conductometric and Potentiometric Titrimetry

50 M

1. Conductometric titration- Determination of concentration of HCl solution using standard NaOH solution.
2. Conductometric titration- Determination of concentration of CH₃COOH Solution using standard NaOH solution.
3. Conductometric titration- Determination of concentration of CH₃COOH and HCl in a mixture using standard NaOH solution.
4. Potentiometric titration- Determination of Fe (II) using standard K₂Cr₂O₇ solution.

Determination of rate constant for acid catalyzed ester hydrolysis



A.G & S.G. SIDDHARTHA DEGREE COLLEGE OF

ARTS & SCIENCE

Vuyyuru-521165

NAAC recredited at "A" level

Autonomous -ISO 9001 – 2015 Certified

Title of the Paper: ANALYTICAL METHODS IN CHEMISTRY

Semester: VI

Course Code	CHE-601GE	Course Delivery Method	Class Room / Blended Mode
Credits	3	CIA Marks	30
No. of Lecture Hours / Week	4	Semester End Exam Marks	70
Total Number of Lecture Hours	60	Total Marks	100
Year of Introduction : 2017-18	Year of Offering: 2021 - 22	Year of Revision: -----	Percentage of Revision: 0

Syllabus

Course Details

Unit	Learning Units	Lecture Hours
I	<p>Quantitative analysis: (Marks weightage 10+5) Methods of different types of chemical analysis, Principle of volumetric analysis. Theories of acid-base, redox, complexometric, iodometric and precipitation titrations - choice of indicators for these titrations.</p>	15h
II	<p>Treatment of analytical data: (Marks weightage 10+5) Types of errors, significant figures and its importance, accuracy - methods of expressing accuracy, error analysis and minimization of errors, precision - methods of expressing precision, standard deviation and confidence limit.</p>	8h
III	<p>Separation Techniques in Chemical analysis (Marks weightage 10+10+5) Solvent extraction: Introduction, principle, techniques, factors affecting solvent Extraction, Batch extraction, continuous extraction. Synergism. Application - Determination of Iron (III), organic mixture analysis.</p>	15h
IV	<p>Chromatography (Marks weightage 10+10+5+5) Classification of chromatography methods, principles of differential migration adsorption phenomenon, Nature of adsorbents, solvent systems, R_f values, factors effecting R_f values. Ion exchange Chromatography: Introduction, action of ion exchange resins, separation of inorganic mixtures, applications. Paper Chromatography : Principle, experimental procedures, choice of paper and solvent systems, developments of chromatogram - ascending, descending and radial.</p>	12h

	Two dimensional chromatography, applications.	
V	<p>Thin layer Chromatography (TLC): (Marks weightage 10+10+5+5) Principles, Experimental procedures. Adsorbents and solvents. Preparation of plates. Development of the chromatogram. Detection of the spots. Applications.</p> <p>Column Chromatography: Principles, experimental procedures, Stationary and mobile Phases, Separation technique. Applications. GC: Principle and applications, HPLC: Basic principle and applications.</p>	10h

List of Reference Books

1. Analytical Chemistry by Skoog and Miller
2. A textbook of qualitative inorganic analysis by A.I. Vogel
3. Nanochemistry by Geoffrey Ozin and Andre Arsenault
4. Stereochemistry by D. Nasipuri
5. Organic Chemistry by Clayden

**A.G. & S.G.SIDDHARTHA DEGREE COLLEGE OF ARTS & SCIENCE
(AUTONOMOUS), VUYYURU
(Accredited at "A" Grade by NAAC, Bangalore)**

Model question paper

SEMESTER – VI	PAPER CODE : CHE-601GE
PAPER TITLE : ANALYTICAL METHODS IN CHEMISTRY, PAPER-VII,	
Model question paper- AC-2021-22	

Time: 3Hours

Maximum marks: 70

Pass marks: 28

SECTION-A

Answer any **FOUR** of the following. Each question carries 5 marks. 4X5=20M

1. Explain the principals involved in chemical analysis
2. Define precession write the methods of expressive precession.
3. Write the applications of Solvent extraction.
4. Write the Principle of differential migration of adsorption phenomenon.
5. Write a short note on Nature of adsorbent
6. Write the Principles of TLC and give their applications.
7. Write the development methods of chromatograms.

SECTION-B

Answer any FIVE questions. Each question carries 10 marks. 5X10=50M

8. Explain about (a)Complexometric titrations (b) Idometric titrations
9. Explain the Choice of indicators for Acid -base and Redox titrations.
10. Define and explain the methods of expressing Accuracy.
11. Discuss the principle, factors affecting the solvent extraction and write the applications of solvent extraction.
12. Discuss the Separation of in organic mixtures by using ion exchange method.
13. Explain the classification of Chromatographic methods.
14. How to prepare plates in TLC.
15. Explain principle and applications of HPLC.

**The Guidelines to be followed by the question paper setters in chemistry for the
VI- Semester - end exams –Academic year -2021-22**

SEMESTER – VI	PAPER CODE : CHE-601GE
PAPER TITLE : ANALYTICAL METHODS IN CHEMISTRY, PAPER-VII	

syllabus	Section-A (Short answer questions)	Section-B (Essay questions)
Unit-1 (15 Marks)	1	1
Unit-2 (15 Marks)	1	1
Unit-3 (25 Marks)	1	1+1
Unit-4 (30 Marks)	1+1	1+1
Unit-5 (30 Marks)	1 +1	1 + 1

- Each Short answer question carries 5 marks in Section –A
- Each Essay question carries 10 marks in Section –B
- The Question papers setters are requested to cover all the topics in the syllabus stipulated as per the weightage given by us.

**A.G.&S.G.SIDDHARTHA DEGREE COLLEGE OF ARTS & SCIENCE
(AUTONOMOUS), VUYYURU.**

(Accredited at "A" Grade by NAAC, Bangalore)

PRACTICAL SYLLABUS

Practical Paper – I Analysis of SALTMIXTURE	PAPER CODE : CHE-601GE ACADEMIC YEAR-2021-2022
--	---

1. Identification of amino acids by paper chromatography.
2. Determination of Zn using EDTA
3. Determination of Mg using EDTA
4. Hardness of water.

SCHEME OF VALUATION

1. INTERNAL MARKS- Record-10M
2. EXTERNAL MARKS-40
 - Titrimetric analysis -30
 - Viva-10

TOTAL = 50 M__



A.G & S.G. SIDDHARTHA DEGREE COLLEGE OF

ARTS & SCIENCE

Vuyyuru-521165

NAAC recredited at “A” level

Autonomous -ISO 9001 – 2015 Certified

Title of the Paper: ORGANIC SPECTROSCOPIC TECHNIQUES

Semester: VI

Course Code	CHE-602CE	Course Delivery Method	Class Room / Blended Mode
Credits	3	CIA Marks	30
No. of Lecture Hours / Week	4	Semester End Exam Marks	70
Total Number of Lecture Hours	60	Total Marks	100
Year of Introduction : 2017-18	Year of Offering: 2021 – 22	Year of Revision: -----	Percentage of Revision: 0

Syllabus

Course Details

Unit	Learning Units	Lecture Hours
I	<p>NUCLEAR MAGNETIC RESONANCE SPECTROSCOPY (Marks weightage 10+10+5)</p> <p>Nuclear spin, Principles of NMR-Classical and Quantum Mechanical methods, Larmour Frequency. Instrumentation. Saturation, Relaxation spin-spin & spin lattice relaxation. Chemical shifts -Factors influencing Chemical shift, Shielding and De-shielding mechanism.</p>	15h
II	<p>NUCLEAR MAGNETIC RESONANCE SPECTROSCOPY (Marks weightage 10+5)</p> <p>Spin-Spin interactions-factors affecting spin-spin interactions, Deuterium exchange (H^+) Coupling constant- types of coupling constant-vicinal, Geminal and long range coupling constant-Factors influencing coupling constants. Types of PMR Spectrums –AX, AX₂ and AB type with one example.</p>	8h
III	<p>Electron Spin Resonance Spectroscopy (Marks weightage 10+10+5+5)</p> <p>Basic Principles, Theory of ESR, Comparison of NMR & ESR.Instrumentation, Factors affecting the 'g' value, determination of 'g' value. Isotropic and Anisotropic constants. Splitting hyper fine splitting coupling constants. Line width, Zero field splitting and Kramer degeneracy. Crystal field splitting,Crystal field effects.Applications:- Detection of free radicals, ESR spectra of (a) H- radical (b)Deuterium radical (c) Methyl radical(CH₃) (d) Benzene anion (C₆H₆) (e) [Cu(H₂O)₆]⁺²</p>	14h
IV	UV & VISIBLE SPECTROSCOPY	

	(Marks weightage 10+10+5+5)	
	Electronic spectra of diatomic molecules. The Born- oppenheimer approximation. Vibration coarse structure: Intensity of Vibrational-electronic spectra: The Franck-Condon principle. Electronic structure of diatomic molecules. Types of transitions, Chromophores, Auxochrome, types of shifts in UV Visible spectrum, Conjugated dienes, trienes and polyenes, unsaturated carbonyl compounds-Woodward – Fieser rules.	15h
V	<p style="text-align: center;">Electronic spectra of polyatomic molecules</p> <p style="text-align: center;">(Marks weightage 10+5)</p> <p>Chemical analysis by Electronic Spectroscopy – Beer-Lambert’s Law. Deviation from Beer’s law. Quantitative determination of metal ions (Mn^{+2}, Fe^{+2}). Simultaneous determination of Chromium and Manganese in a mixture.</p>	8h

REFERENCE BOOKS:

1. Electron Spin Resonance Elementary Theory and Practical Applications- John E. Wertz and James R. Bolton, Chapman and Hall, 1986.
2. Spectroscopic Identification of organic compounds – Silverstein, Basseler and Morrill.
3. Organic Spectroscopy- William Kemp.
4. Fundamentals of Molecular Spectroscopy- C.N.Banwell and E.A. Mc cash 4thEdition, Tata Mc GrawHillPublishing Co., Ltd. 1994.
5. Physical Methods in Inorganic Chemistry – R.S.Drago, Saunders Publications.
6. Application of Mössbauer Spectroscopy – Green Mood.
7. NMR, NQR, EPR and Mössbauer Spectroscopy in inorganic chemistry – R.VParish, Ellis, Harwood.

**A.G. & S.G.SIDDHARTHA DEGREE COLLEGE OF ARTS & SCIENCE
(AUTONOMOUS), VUYYURU
(Accredited at "A" Grade by NAAC, Bangalore)**

Model question paper

SEMESTER – VI

PAPER CODE : CHE-602CE

PAPER TITLE : : ORGANIC SPECTROSCOPIC TECHNIQUES, PAPER-VIII, Model question paper- AC-2021-

22

Time: 3Hours

Maximum marks: 70

Pass marks: 28

Answer any FOUR of the following. Each question carries 5 marks.

4X5=20M

1. Write about Nuclear spin?
2. Write any two types of coupling constant?
3. Write about Kramer degeneracy?
4. What is isotropic and anisotropic constants?
5. Explain Woodward-Fieser rules?
6. Write a short note on Auxochrome?
7. Define and derive Beer-Lambert's law.

SECTION-B

Answer any FIVE questions. Each question carries 10 marks.

5X10=50M

8. Explain the instrumentation of the NMR?
9. Explain Spin-Spin relaxation and spin lattice relaxation.
10. Write the types of PMR spectrums of AX, AX₂ & AB?
11. Explain the instrumentation of the ESR.
12. Explain the ESR splitting of a) Deuterium radical b) [Cu(H₂O)₆]⁺² ion
13. Explain the electronic spectra of di atomic molecule.
14. Write note on Vibrational coarse structure.
15. Explain the simultaneous determination of Chromium and Manganese in a mixture.

The Guidelines to be followed by the question paper setters in chemistry for the VI-Semester - end exams Academic year- 2021-22

**PAPER TITLE: ORGANIC SPECTROSCOPIC TECHNIQUES,
PAPER CODE: CHE-602CE**

Paper – VIII Maximum marks : 70 Duration : 3 Hours

Weightage for the question paper

syllabus	Section-A (Short answer questions)	Section-B (essay questions)
Unit-1 (25Marks)	1	1+1
Unit-2 (15 Marks)	1	1
Unit-3 (30Marks)	1+1	1+1
Unit-4 (30Marks)	1+1	1+1
Unit-5 (15Marks)	1	1

- Each Short answer question carries 5 marks in Section –A
- Each Essay question carries 10 marks in Section –B
- The Question papers setters are requested to cover all the topics in the syllabus stipulated as per the weightage given by us.



A.G & S.G. SIDDHARTHA DEGREE COLLEGE OF

ARTS & SCIENCE

Vuyyuru-521165

NAAC recredited at "A" level

Autonomous -ISO 9001 – 2015 Certified

Title of the Paper: ADVANCED ORGANIC REACTIONS

Semester: VI

Course Code	CHE-603CE	Course Delivery Method	Class Room / Blended Mode
Credits	3	CIA Marks	30
No. of Lecture Hours / Week	4	Semester End Exam Marks	70
Total Number of Lecture Hours	60	Total Marks	100
Year of Introduction : 2017-18	Year of Offering: 2021 – 22	Year of Revision: -----	Percentage of Revision: 0

Syllabus

Course Details

Unit	Learning Units	Lecture Hours
I	<p>ORGANIC PHOTO CHEMISTRY (Marks weightage 10+10+5)</p> <p>Organic photochemistry: Molecular orbitals, carbonyl chromophore–Jablonski diagram, Photochemical reactions- Photo reduction-mechanism, example-aromatic compounds. Sensitizer and influence of sensitizer.</p>	10h
II	<p>ORGANIC PHOTOCHEMISTRY (Marks weightage 10+10+5)</p> <p>Norrish cleavages, type -I: Mechanism, acyclic cyclic diones, Photo Fries rearrangement. Norrish type II cleavage: Mechanism and stereochemistry, Type- II reactions of esters: 1: 2 diketones, photo decarboxylation, Di-π methane Rearrangement, Photochemistry – of conjugated dienes, Decomposition of nitrites –Barton reaction.</p>	12h
III	<p>PROTECTING GROUPS AND ORGANIC REACTIONS (Marks weightage 10+10+5+5)</p> <p>Principles of (1) Protection of alcohols – ether formation including silyl ethers – ester formation, (2) Protection of diols – acetal,ketal and carbonate formation, (3) Protection of carboxylic acids – ester formation, benzyl and t-butyl esters, (4) Protection of amines– acetylation, benzylation, benzyloxy carbonyl, triphenyl methyl groups and fmoc, (5)Protection of carbonyl groups – acetal, ketal, 1,2-glycols and 1,2-dithioglycols formation.</p>	15h
IV	<p>SYNTHETIC REACTIONS: (Marks weightage 10+5+5)</p> <p>Mannich reaction – Mannich bases – Robinson annulations. The Shapiro reaction, Stork–enamine reaction. Use of dithioacetals – Umpolung, phase transfercatalysis – mechanisms and use of</p>	8h

	benzyl trialkyl ammonium halides. Wittig reaction.	
V	<p>NEW SYNTHETIC REACTIONS (Marks weightage 10+5)</p> <p>Define with example and mechanism- Suzuki coupling, Click reaction, Baylis–Hillman reaction, RCM olefin metathesis, Mukayama aldol reaction.</p> <p>Define with one example: (Mechanism not required) Mitsunobu reaction, McMurrey reaction, Julia–Lythgoe olefination, Stille coupling and Heck reaction.</p>	15h

Recommended Books

1. Molecular reactions and Photochemistry by Charles Dupey and O.L. Chapman.
2. Molecular Photochemistry by Turru.
3. Importance of antibonding orbitals by Jaffe and Orchin.
4. Text Book of Organic Chemistry by Cram, Hammand and Henrickson.
5. Some modern methods of organic synthesis by W. Carruthers.
6. Guide Book to Organic Synthesis by R.K. Meckie, D.M. Smith and R.A. Atken.
7. Organic Synthesis by O. House.
8. Organic synthesis by Michael B. Smith.

**A.G. & S.G.SIDDHARTHA DEGREE COLLEGE OF ARTS & SCIENCE
(AUTONOMOUS), VUYURU
(Accredited at "A" Grade by NAAC, Bangalore)**

Model question paper

SEMESTER – VI	PAPER CODE : CHE-603CE
PAPER TITLE : ORGANIC SPECTROSCOPIC TECHNIQUES, PAPER-IX, <u>Model question paper- AC-2021-22</u>	

Time: 3Hours

Maximum marks: 70

Pass marks: 28

SECTION-A

Answer any FOUR of the following. Each question carries 5 marks.

4X5=20M

1. Write about Chromophore triplet state?
2. Write about Barton reaction?
3. Explain how to protect the Carbonyl group?
4. Explain how to protect the Diols?
5. Explain about Umpolung?
6. Explain PTC with mechanism?
7. Explain Suzuki coupling?

SECTION-B

Answer any FIVE questions. Each question carries 10 marks.

5X10=50M

8. Explain about Jablonski diagram in organic photo chemistry?
9. Explain mechanism of photo reduction with examples?
10. Explain Norrish type –I cleavage with mechanism?
11. Explain Norrish type –II cleavage with mechanism?
12. Explain how to protect Alcohols?
13. Explain how to protect Carboxylic acids?
14. What is Mannich reaction? Explain with mechanism and Mannich bases?
15. Write the mechanism of Baylis-Hillman reaction and RCM Olefination?

The Guidelines to be followed by the question paper setters in chemistry for the VI-Semester - end exams Academic year- 2021-22

PAPER TITLE: ADVANCED ORGANIC REACTIONS, PAPER CODE: CHE-603CE

Paper – VIII

Maximum marks : 70

Duration : 3 Hours

Weightage for the question paper

syllabus	Section-A (Short answer questions)	Section-B (essay questions)
Unit-1 (25Marks)	1	1+1
Unit-2 (25 Marks)	1	1+1
Unit-3 (30 Marks)	1+1	1+1
Unit-4 (20Marks)	1+1	1
Unit-5 (15 Marks)	1	1

- Each Short answer question carries 5 marks in Section –A
- Each Essay question carries 10 marks in Section –B
- The Question papers setters are requested to cover all the topics in the syllabus stipulated as per the weightage given by us.



A.G & S.G. SIDDHARTHA DEGREE COLLEGE OF

ARTS & SCIENCE

Vuyyuru-521165

NAAC recredited at “A” level

Autonomous -ISO 9001 – 2015 Certified

Title of the Paper: PHARMACEUTICAL AND MEDICINAL CHEMISTRY

Semester: VI

Course Code	CHE-604CE	Course Delivery Method	Class Room / Blended Mode
Credits	3	CIA Marks	30
No. of Lecture Hours / Week	4	Semester End Exam Marks	70
Total Number of Lecture Hours	60	Total Marks	100
Year of Introduction : 2017-18	Year of Offering: 2021 - 22	Year of Revision: -----	Percentage of Revision: 0

Syllabus

Course Details

Unit	Learning Units	Lecture Hours
I	<p>Pharmaceutical chemistry Terminology: (Marks weightage 10+5+5)</p> <p>Pharmacy, Pharmacology, Pharmacophore, Pharmacodynamics, Pharmacokinetics (ADME, Receptors - brief treatment) Metabolites and Anti metabolites.</p>	12h
II	<p>Drugs (Marks weightage 10+10+5)</p> <p>Nomenclature: Chemical name, Generic name and trade names with 10-examples Classification based on structures and therapeutic activity with one example each.</p>	10h
III	<p>Synthesis and therapeutic activity of the compounds:</p> <p>Chemotherapeutic Drugs (Marks weightage 10+10+5) 1.Sulphadruugs(Sulphamethoxazole) 2.Antibiotics - β-Lactam Antibiotics-Isolation of Pencilline by submerged culture method, 3. Anti malarial Drugs (chloroquine).</p> <p>Psycho therapeutic Drugs: (Marks weightage 10+5) 1.Antipyretics(Paracetamol)2.Hypnotics,Tranquilizers (Diazepam) 3.Levodopa.</p>	18h
IV	<p>Pharmacodynamic Drugs: (Marks weightage 10+5) 1.Antiasthma Drugs (Solbutamol) 2. Antianginals (Glycerol Trinitrate) 3.Diuretics (Frusemide)</p>	8h
V	<p>HIV-AIDS: (Marks weightage 10+5)</p> <p>Immunity - CD-4cells, CD-8cells, Retro virus, Replication in human body, Investigation available, prevention of AIDS, Drugs available - examples with structures: PIS: Indivanir (crixivan), Nelfinavir(Viracept).</p>	12h

List of Reference Books:

1. Medicinal Chemistry by Dr. B.V.Ramana
2. Synthetic Drugs by O.D.Tyagi & M.Yadav
3. Medicinal Chemistry by Ashutoshkar
4. Medicinal Chemistry by P.Parimoo
5. Pharmacology & Pharmacotherapeutics R.S Satoshkar & S.D.Bhandenkar

**A.G. & S.G.SIDDHARTHA DEGREE COLLEGE OF ARTS & SCIENCE
(AUTONOMOUS), VUYYURU
. (Accredited at "A" Grade by NAAC, Bangalore)**

Model question paper

SEMESTER – VI

PAPER CODE : CHE-604CE

PAPER TITLE : PHARMACEUTICAL AND MEDICINAL CHEMISTRY, PAPER-IX, Model question paper- AC-2021-22

Time: 3Hours

Maximum marks: 70

Pass marks: 28

SECTION-A

Answer any FOUR of the following. Each question carries 5 marks. 4X5=20M

1. What are Metabolites and anti metabolites? Explain with example.
2. Write a note on Pharmacology and Pharmacophore.
3. Explain the classification of drugs on the basis of structure.
4. Describe the synthesis and therapeutic activities of Sulphamethoxazole.
5. Write the synthesis,therapeutic activity and side effects of paracetamol.
6. Write a note on Antianginals.
7. Explain about immunity.

SECTION-B

Answer any FIVE questions. Each question carries 10 marks. 5X10=50M

8. What are Pharma cokinetics ? Describe Absorption,Distribution,Metabolism and Excretion(ADME)of drug.
9. Explain the classification of drugs based on therapeutic activity with examples.
10. Describe the nomenclature systems of drugs.
11. What are antibiotics? Give examples. Explain the isolation method of Pencillin by submerged culture method.
12. Write the synthesis, therapeutic activity and side effects of Chloroquine.
13. Discuss the synthesis and therapeutic activity of Levodopa.
14. Explain in detail about antiasthma drugs.
15. What is AIDS ?How it causes ? Write the drugs available for the treatment of AIDS with their structure?

The Guidelines to be followed by the question paper setters in chemistry for the VI-Semester - end exams Academic year-2021-22

PAPER TITLE: PHARMACEUTICAL AND MEDICINAL CHEMISTRY,

PAPER CODE: CHE-604CE

Paper – VIII-C-3 Semester – VI Maximum marks : 70 Duration : 3 Hours

Weightage for the question paper

syllabus	Section-A (Short answer questions)	Section-B (essay questions)
Unit-1 (20 Marks)	1+1	1
Unit-2 (25Marks)	1	1+1
Unit-3 (40Marks)	1+1	1+1+1
Unit-4 (15 Marks)	1	1
Unit-5 (15Marks)	1	1

- Each Short answer question carries 5 marks in Section –A
- Each Essay question carries 10 marks in Section –B
- The Question papers setters are requested to cover all the topics in the syllabus stipulated as per the weightage given by us.

**A.G.&S.G.SIDDHARTHA DEGREE COLLEGE OF ARTS & SCIENCE
(AUTONOMOUS), VUYYURU.**

(Accredited at "A" Grade by NAAC, Bangalore)

PRACTICAL SYLLABUS

Practical Paper – I Preparations of Organic compounds	PAPER CODE : CHE-602CE ACADEMIC YEAR-2021-2022
--	---

30 hrs (2 h / W)

Credits-2

1. Preparation of Aspirin.
2. Preparation of Paracetamol.
3. Preparation of Acetanilide
4. Preparation of Barbituric Acid.
5. Preparation of Phenyl Azo β -naphthol.

SCHEME OF VALUATION

1. INTERNAL MARKS- Record-10M
2. EXTERNAL MARKS-40M
 - Titrimetric analysis -30
 - Viva-10

TOTAL = 50 M__

**A.G.&S.G.SIDDHARTHA DEGREE COLLEGE OF ARTS & SCIENCE
(AUTONOMOUS), VUYYURU.**

(Accredited at “A” Grade by NAAC, Bangalore)

PRACTICAL SYLLABUS

Practical Paper – I Preparations of Organic compounds by Green procedure	PAPER CODE : CHE-603CE ACADEMIC YEAR-2021-2022
---	---

30 hrs (2h / W),

Credits-2

1. Green procedure for organic qualitative analysis: Detection of N, S and halogens
2. Acetylation of 1^o amine by green method: Preparation of acetanilide
3. Rearrangement reaction in green conditions: Benzil-Benzilic acid rearrangement
4. Electrophilic aromatic substitution reaction: Nitration of phenol
5. Radical coupling reaction: Preparation of 1, 1-bis -2-naphthol
6. Green oxidation reaction: Synthesis of Adipic acid
7. Green procedure for Diels Alder reaction between furan and Maleic anhydride

SCHEME OF VALUATION

1. INTERNAL MARKS- Record-10M
2. EXTERNAL MARKS-40 M
 - Practical -30
 - Viva-10

TOTAL = 50 M__

**A.G.&S.G.SIDDHARTHA DEGREE COLLEGE OF ARTS & SCIENCE
(AUTONOMOUS), VUYYURU.**

(Accredited at “A” Grade by NAAC, Bangalore)

PRACTICAL SYLLABUS

Practical Paper – I Project work	PAPER CODE : CHE-604CE ACADEMIC YEAR-2021-2022
---	---

The students have chosen chemistry as cluster elective.

“Spectral analysis of various shaded dried leaves powder extract with polar and non-polar solvents using IR and UV spectroscopies” is selected as a project work to the students for this academic year.

SCHEME OF VALUATION

1. EXTERNAL- 25M- given by the Examiner (Viva)

2. INTERNAL = 25 M

- Written viva-10 M
- Submission of the project book-15M

TOTAL = 50 M__

**A.G& S.G.SIDDHARTHA DEGREE COLLEGE OF ARTS &
SCIENCE**

VUYYURU-521165, KRISHNA Dt., A.P.(Autonomous)

Accredited by NAAC with "A" Grade

2021-2022



DEPARTMENT OF MATHEMATICS

MINUTES OF BOARD OF STUDIES

ODD SEMESTER

10-11-2021

Minutes of the meeting of BOS in Mathematics for B.Sc Degree Courses of
AG & SG Siddhartha Degree College of Arts & Science, Vuyyuru, held at 2.30
PM on 10 – 11 – 2021.

N.V. Srinivasa Rao

Presiding

Members Present:

- | | | |
|---|-----------------------|---|
| 1) <u><i>N.V. Srinivasa Rao</i></u>
(N.V. Srinivasa Rao) | Chairman | Head, Department of
Mathematics,
AG & SG S Degree College. |
| 2) <u><i>K. Jaya Lakshmi</i></u>
(Dr. K. Jaya Lakshmi) | University
Nominee | Department of Mathematics,
Krishna University,
Machilipatnam. |
| 3) <u><i>M. Venkateswara Rao</i></u>
(M. Venkateswara Rao) | Subject
Expert | Department of Mathematics,
Govt. Degree College,
Avanigadda. |
| 4) <u><i>I. V. Venkateswara Rao</i></u>
(I. V. Venkateswara Rao) | Subject
Expert | Department of Mathematics,
P. B. Siddhartha College,
Vijayawada |
| 5) <u><i>D. Sunitha</i></u>
(D. Sunitha) | Member | Lecturer in Mathematics
AG & SG S Degree College. |
| 6) <u><i>A. Bhargavi</i></u>
(A. Bhargavi) | Member | Lecturer in Mathematics
AG & SG S Degree College. |
| 7) <u><i>Noor Mohammad</i></u>
(Noor Mohammad) | Member | Lecturer in Mathematics
AG & SG S Degree College. |
| 8) <u><i>K. Rajya Lakshmi</i></u>
(K. Rajya Lakshmi) | Member | Lecturer in Mathematics
AG & SG S Degree College. |
| 9) <u><i>B. Durga Praveen</i></u>
(B. Durga Praveen) | Student
Member | III B.Sc M.C.Cs
AG & SG S Degree College. |
| 10) <u><i>M. Rose Manasa</i></u>
(M. Rose Manasa) | Student
Member | III B.Sc M.P.C (E)
AG & SG S Degree College. |

Agenda of B.O.S Meeting:

1. To discuss and recommend the Syllabi, Model Question Papers and Guidelines to be followed by question paper setters in Mathematics for 1st Semester as per the guidelines and instructions under CBCS prescribed by Krishna University from the Academic Year 2021-22.
2. To discuss and recommend the Syllabi, Model Question Papers and Guidelines to be followed by question paper setters in Mathematics and Analytical Skills for 3rd Semester as per the guidelines and instructions under CBCS prescribed by Krishna University from the Academic Year 2021-22.
3. To discuss and recommend the Syllabi, Model Question Papers and Guidelines to be followed by question paper setters in Mathematics for 5th Semester as per the guidelines and instructions under CBCS prescribed by Krishna University from the Academic Year 2021-22.
4. Any other matter.

Resolutions.

1. Discussed and recommended that changes are required in Syllabi, Model Question Papers and Guidelines to be followed by the question paper setters in Mathematics for 1st Semesters from the Academic year 2021-22. The maximum marks for IA is 25 and SE is 75. Each IA written examination is of 1 Hr. 30 min duration for 20 marks. The tests will be conducted centrally. The average of two such IA is calculated for 20 marks. 5 marks will be allotted basing on Assignment. There is no minimum passing for IA and there is no provision for improvement in IA. Even though the candidate is absent for two IA exams/obtain zero marks the external marks are considered (if he/ she gets 40 out of 75) and the result shall be declared as 'PASS' from the Academic year 2021-22.
2. Discussed and recommended that changes are required in Syllabi, Model Question Papers and Guidelines to be followed by the question paper setters in Mathematics and Analytical Skills for all degree programs of 3rd Semesters from the Academic year 2021-22. The maximum marks for IA is 30 and SE is 70. Each IA written examination is of 1 Hr. 30 min duration for 20 marks. The tests will be conducted centrally. The average of two such IA is calculated for 20 marks. 5 marks will be allotted basing on Assignment and 5 marks are allotted for attendance. There is no minimum passing for IA and there is no provision for improvement in IA. Even though the candidate is absent for two IA exams/obtain zero marks the external marks are considered (if he/ she gets 40 out of 70) and the result shall be declared as 'PASS' from the Academic year 2021-22. There is no IA for Analytical Skills and minimum pass marks is 20 out of 50 in SE.
3. Discussed and recommended that no changes are required in syllabi, Model Question Papers and Guidelines for question paper setters in Mathematics for the 5th Semester for the Academic year 2021-22.
4. Discussed and recommended for organizing seminars, Guest lecturers, Online Examinations and Workshops to upgrade the knowledge of students for Competitive Examinations for the approval of the Academic Council.

V. Srinivasan
Chairman

University Nominee

M. Venkatesh
Subject Expert

J. Venkatesh
Subject Expert

A . G & S . G Siddhartha Degree College of Arts and Science (Autonomous), Vuyyuru

(An Autonomous College in the jurisdiction of Krishna University, Machilipatnam)
NAAC reaccredited at 'A' level and *ISO 9001 – 2015 Certified*

Department of Mathematics**COURSE STRUCTURE****Paper Title :- DIFFERENTIAL EQUATIONS****Semester : I**

Course Code	MATT11A	Course Delivery Method	Class Room / Blended Mode - Both
Credits	5	CIA Marks	30
No. of Lecture Hours / Week	6	Semester End Exam Marks	70
Total Number of Lecture Hours	90	Total Marks	100
Year of Introduction : 2018-19	Year of Offering: 2022 - 23	Year of Revision: ----	Percentage of Revision: 0%

Programme Outcomes

S. No	P.O
	At the end of the Programme the student will be able to:
1	Demonstrate the ability to use mathematical skills such as formulating and tackling mathematics related problems and identifying and applying approximate physical principles and methodologies to solve a wide range of problems associated with mathematics.
2	Apply the underlying unifying structures of mathematics and the relationships among them.
3	Investigate and apply mathematical problems and solutions in variety of contexts related to science and technology, business and industry.

Course Outcomes of MATT11A

S. No	C.O	Mapping
	Upon successful completion of this course, students should have the knowledge and skills to:	
1	Determine the solution of differential equations of the first order and of the first degree by Exact, Linear and Bernoulli's method.	L2, PO – 1
2	Understand the basic concepts of first order differential equations to find Orthogonal trajectories.	L2, PO - 1
3	Determine the solution of differential equations of the first order and of a degree higher than first by using methods of solvable for P, X, and Y.	L2, PO - 1
4	Compute all solutions of second and higher order linear differential equations with constant coefficients, linear equations with variable coefficients.	L3, PO – 1
5	Calculate the solutions of higher order differential equations by Cauchy Euler and Variation of parameters.	L2, PO – 1

A . G & S . G Siddhartha Degree College of Arts and Science (Autonomous), Vuyyuru

(An Autonomous College in the jurisdiction of Krishna University, Machilipatnam)

MATHEMATICS	MAT T11A	2021 – 22 onwards	B.Sc (MPC, MPCS, MCCS, MSCS)
--------------------	-----------------	--------------------------	-------------------------------------

DIFFERENTIAL EQUATIONS

SEMESTER-I

No of Credits: 5

OBJECTIVES:

1. Understand all of the concepts relating to the order and linearity of ODEs, analytic and computational solution methods for ODEs, and the real-world applications of ODEs.
2. Apply your understanding of the concepts, formulas, and problem-solving procedures to thoroughly investigate relevant physical models.
3. Explain the concepts of linear systems, ODE solution methods, and related ideas at a fundamental level, as well as how and why we use the solution techniques that we use.

UNIT-I: DIFFERENTIAL EQUATIONS OF FIRST ORDER& FIRST DEGREE (12Hrs)

- 1.1 Linear Differential Equations
- 1.2 Differential Equations Reducible to Linear Form, Bernoulli's differential equations.
- 1.3 Exact Differential Equations
- 1.4 Integrating Factors, $1/Mx+Ny$, $1/Mx-Ny$, $e^{\int f(x)} dx$, $e^{\int g(y)} dy$, and Inspection method
- 1.5 Change of Variables

UNIT-II: ORTHOGONAL TRAJECTORIES &DIFFERENTIAL EQUATIONS OF FIRST ORDER BUT NOT FIRST DEGREE (12Hrs)

- 2.1 Orthogonal Trajectories
- 2.2 Self-Orthogonal Trajectories
- 2.3 Equations solvable for p
- 2.4 Equations solvable for y
- 2.5 Equations solvable for x
- 2.6 Equations Homogeneous in X & Y
- 2.7 Equations that do not contain x (or y)
- 2.8 Clairaut's Equation and Equations reducible to Clairaut's form.

UNIT – III: Higher order linear differential equations-I (12Hrs)

- 3.1 Solution of homogeneous linear differential equations of order n with constant coefficients
- 3.2 Solution of the non-homogeneous linear differential equations with constant coefficients by means of polynomial operators.
- 3.3 General Solution of $f(D)y=0$
- 3.4 General Solution of $f(D)y=Q$ when Q is a function of x.
- 3.5 $1/f(D)$ is Expressed as partial fractions.
- 3.6 P.I. of $f(D) y = Q$ when $Q= be^{ax}$
- 3.7 P.I. of $f(D) y = Q$ when Q is $b \sin ax$ or $b \cos ax$.

UNIT – IV: Higher order linear differential equations-II (12Hrs)

- 4.1 Solution of the non-homogeneous linear differential equations with constant coefficients.
- 4.2 P.I. of $f(D) y = Q$ when $Q= bx^k$
- 4.3 P.I. of $f(D) y = Q$ when $Q= e^{ax}V$
- 4.4 P.I. of $f(D) y = Q$ when $Q= xV$
- 4.5 P.I. of $f(D) y = Q$ when $Q= x^mV$ where $v = \sin bx$ and $\cos bx$

UNIT-V: Higher order Differential Equations –III (12Hrs)

- 5.1 The Cauchy-Euler Equation.
- 5.2 Linear differential Equations with non-constant coefficients
- 5.3 Method of Variation of parameters.

Student Activities:

- 1) **Class-room activities:** Power point presentations, Assignments
- 2) **Library activities:** Visit to library and preparation of notes for Assignment problems.
- 3) **Activities in the Seminars, workshops and conferences:** Participation/presentation in seminar/workshop/conference.

CO-CURRICULAR ACTIVITIES:

- Quiz Competitions, Seminars
- Group Discussions

WEB LINKS:

https://en.wikipedia.org/wiki/Differential_equation

<https://tutorial.math.lamar.edu/classes/de/de.aspx>

<https://www.mathsisfun.com/calculus/differential-equations.html>

Prescribed Text book:				
S.NO	AUTHOR	TITLE OF THE BOOK	PUBLISHER	YEAR OF PUBLICATION
1	V. Krishna Murthy	A text book of Mathematics for B.A/B.ScVol – I	S-Chand&co	2015

Reference books:				
S.NO	AUTHOR	TITLE OF THE BOOK	PUBLISHER	YEAR OF PUBLICATION
1	Dr.A. Anjaneyulu	A text book of mathematics for B.A/B.ScVol – I	Deepthi Publications	2015
2	Rai Singhania	Ordinary& Partial Differential Equations	S-Chand	2009
3	Zafar Ahsan	Differential Equations and their applications	Prentice-Hall of India Pvt Ltd, McGraw Hill	2000

Recommended Question Paper Pattern and Model BLUE PRINT FOR QUESTION PAPER
PATTERN COURSE-I, DIFFERENTIAL EQUATIONS

Unit	TOPIC	S.A.Q(including choice)	E.Q(including choice)	Total Marks
I	Differential Equations of 1 st order and 1 st degree	2	2	28
II	Orthogonal Trajectories, Differential Equations of 1 st order but not of 1 st degree	2	2	28
III	Higher Order Linear Differential Equations (with constant coefficients) – I	2	2	28
IV	Higher Order Linear Differential Equations (with constant coefficients) – II	2	2	28
V	Higher Order Linear Differential Equations (with non-constant coefficients)	2	2	28
TOTAL		10	10	140

S.A.Q. = Short answer questions (4 marks)

E.Q. = Essay questions (10 marks)

Total Marks = 70 M

.....

COURSE-I, DIFFERENTIAL EQUATIONS

B.Sc MATHEMATICS MODEL PAPER (W.E.F 2022 – 2023)

Time: 3Hrs

Max.Marks:70M

Answer the following questions.

5 x 14 = 70M

1. (a) i) ----- 10 M
ii) ----- 4M
(OR)

(b) i) ----- 10M
ii) ----- 4 M

2. (a) i) ----- 10 M
ii) ----- 4M
(OR)

(b) i) ----- 10M
ii) ----- 4 M

3. (a) i) ----- 10 M
ii) ----- 4M
(OR)

(b) i) ----- 10M
ii) ----- 4 M

4. (a) i) ----- 10 M
ii) ----- 4M
(OR)

(b) i) ----- 10M
ii) ----- 4 M

5. (a) i) ----- 10 M
ii) ----- 4M
(OR)

(b) i) ----- 10M
ii) ----- 4 M

A. G & S. G Siddhartha Degree College of Arts and Science (Autonomous), Vuyyuru

(An Autonomous College in the jurisdiction of Krishna University, Machilipatnam)

NAAC recredited at 'A' level

Autonomous -ISO 9001 – 2015 Certified

Title of the Paper: ABSTRACT ALGEBRA

Semester: III

Course Code	MAT - 301	Course Delivery Method	Class Room / Blended Mode - Both
Credits	5	CIA Marks	30
No. of Lecture Hours / Week	6	Semester End Exam Marks	70
Total Number of Lecture Hours	75	Total Marks	100
Year of Introduction :2021-22	Year of Offering: 2021 - 22	Year of Revision: ---- 2021-22	Percentage of Revision: 0%

Course Outcomes:

After successful completion of this course, the student will be able to;

1. Acquire the basic knowledge and structure of groups, subgroups and cyclic groups.
2. Get the significance of the notation of a normal subgroups.
3. Get the behavior of permutations and operations on them.
4. Study the homomorphisms and isomorphisms with applications.
5. Understand the ring theory concepts with the help of knowledge in group theory and to prove the theorems.
6. Understand the applications of ring theory in various fields.

Course Syllabus:

UNIT – I: GROUPS:

(12 Hours)

Binary Operation – Algebraic structure – semi group- monoid – Group definition and elementary properties

Finite and Infinite groups – examples – order of a group, Composition tables with examples.

UNIT – II: SUB - GROUPS:

(12 Hours)

Complex Definition – Multiplication of two complexes Inverse of a complex-Subgroup definition- examples- criterion for a complex to be a subgroups. Criterion for the product of two subgroups to be a subgroup-union and Intersection of subgroups.

Co-sets and Lagrange's Theorem :

Cosets Definition – properties of Cosets–Index of a subgroups of a finite groups–Lagrange's Theorem.

UNIT –III: NORMAL SUBGROUPS :

(12 Hours)

Definition of normal subgroup – proper and improper normal subgroup–Hamilton group – criterion for a subgroup to be a normal subgroup – intersection of two normal subgroups – Sub group of index 2 is a normal sub group –quotient group – criteria for the existence of a quotient group.

HOMOMORPHISM :

Definition of homomorphism – Image of homomorphism elementary properties of homomorphism – Isomorphism – automorphism definitions and elementary properties–kernel of a homomorphism – fundamental theorem on Homomorphism and applications.

UNIT – IV: PERMUTATIONS AND CYCLIC GROUPS : (12 Hours)

Definition of permutation – permutation multiplication – Inverse of a permutation – cyclic permutations – transposition – even and odd permutations – Cayley’s theorem.

Cyclic Groups :- Definition of cyclic group – elementary properties – classification of cyclic groups.

UNIT – V: RINGS : (12 Hours)

Definition of Ring and basic properties, Boolean Rings, divisors of zero and cancellation laws Rings, Integral Domains, Division Ring and Fields, The characteristic of a ring - The characteristic of an Integral Domain, The characteristic of a Field. Sub rings and Ideals (only definitions)

Co-Curricular Activities (15 Hours)

Seminar/ Quiz/ Assignments/ Group theory and its applications / Problem Solving.

Text Book:

A text book of Mathematics for B.A. / B.Sc. by B.V.S.S. SARMA and others, published by S.Chand & Company, New Delhi.

Reference Books:

1. Abstract Algebra by J.B. Fraleigh, Published by Narosa publishing house.
2. Modern Algebra by M.L. Khanna.
3. Rings and Linear Algebra by Pundir & Pundir, published by Pragathi Prakashan.

A . G & S . G Siddhartha Degree College of Arts and Science (Autonomous), Vuyyuru

(An Autonomous College in the jurisdiction of Krishna University, Machilipatnam)

SEMESTER - III, ABSTRACT ALGEBRA

B.Sc MATHEMATICS MODEL PAPER

Time: 3Hrs

Max.Marks:70M

SECTION - A

Answer any **FOUR** questions. Each question carries **FIVE** marks.
Choosing at least **ONE** question from each part.

4 X 5 M=20 M.

Part – 1

1. Show that the set $G = \{x/ x = 2^a, 3^b \text{ and } a, b \in \mathbb{Z}\}$ is a group under multiplication.
2. Define order of an element of a Group. In a group G if $a \in G$ then $O(a) = O(a^{-1})$.
3. If H and K are two subgroups of a group G , then prove that HK is a subgroup of G
If and only if $HK=KH$
4. If G is a group and H is a subgroup of index 2 in G then prove that H is a normal subgroup.

Part – 2

5. The necessary and sufficient condition for a homomorphism f of a group G on to a group G^1 with kernel K to be an isomorphism of G into G^1 is that $K = \{e\}$
6. Examine whether the following permutations are even or odd
i) $\begin{pmatrix} 1 & 2 & 3 & 4 & 5 & 6 & 7 & 8 & 9 \\ 6 & 1 & 4 & 3 & 2 & 5 & 7 & 8 & 9 \end{pmatrix}$ ii) $\begin{pmatrix} 1 & 2 & 3 & 4 & 5 & 6 & 7 \\ 3 & 2 & 4 & 5 & 6 & 7 & 1 \end{pmatrix}$
7. Prove that a group of prime order is cyclic.
8. Every field is an integral domain.

SECTION - B

Answer any **FIVE** questions. Each question carries **TEN** marks.
Choosing at least **TWO** question from each part

5 X 10 M = 50 M

Part – 1

9. Show that the set Q_+ of all +ve rational numbers forms an abelian group under the composition defined by “ \circ ” such that $a \circ b = ab/3$ for $a, b \in Q_+$
10. Show that the set of n^{th} roots of unity forms an abelian group under multiplication.
11. The Union of two subgroups is also a subgroup \Leftrightarrow one is contained in the other.
12. State and prove Lagrange’s theorem.

Part – 2

13. Prove that a subgroup H of a group G is a normal subgroup of G iff the product of two right coset of H in G is again a right coset of H in G .
14. State and prove fundamental theorem of homomorphisms of groups.
15. Prove that every subgroup of cyclic group is cyclic.
16. Prove that the characteristic of an integral domain is either prime or zero.

BLUE PRINT FOR QUESTION PAPER PATTERN COURSE-III, ABSTRACT ALGEBRA

Unit	TOPIC	S.A.Q (including choice)	E.Q (including choice)	Total Marks
I	Groups	2	2	30
II	Subgroups, Cosets & Lagrange's theorem	1	2	25
III	Normal Subgroups and Homomorphism	2	2	30
IV	Permutations and Cyclic groups	2	1	20
V	Rings	1	1	15
Total		8	8	120

S.A.Q. = Short answer questions (5 marks)

E.Q. = Essay questions (10 marks)

Short answer questions : 4 X 5 M = 20 M

Essay questions : 5 X 10 M = 50 M

.....
Total Marks = 70 M

A.G & S.G SIDDHARTHA DEGREE COLLEGE OF ARTS AND SCIENCE,
VUYYURU-521165, KRISHNA Dt, A.P.
 (An Autonomous College in the jurisdiction of Krishna University, Machilipatnam)
 Accredited with “A” Grade by NAAC, Bengaluru

Title of the Paper: Analytical Skills

Semester: III

Course Code	ANS - 301	Course Delivery Method	Class Room / Blended Mode - Both
Credits	2	CIA Marks	0
No. of Lecture Hours / Week	2	Semester End Exam Marks	50
Total Number of Lecture Hours	30	Total Marks	50
Year of Introduction :2021-22	Year of Offering: 2021 - 22	Year of Revision: ----	Percentage of Revision: 0%

Course Objective: Intended to inculcate quantitative analytical skills and reasoning as an inherent ability in students.

Course Outcomes:

After successful completion of this course, the student will be able to;

- 1) Understand the basic concepts of arithmetic ability, quantitative ability, logical reasoning, business computations and data interpretation and obtain the associated Skills.
- 2) Acquire competency in the use of verbal reasoning.
- 3) Apply the skills and competencies acquired in the related areas
- 4) Solve problems pertaining to quantitative ability, logical reasoning and verbal ability inside and outside the campus.

UNIT – 1

6 Hrs

Test of Reasoning – I:-Coding – Decoding, Direction Test, Interchange of Signs, Logical Venn diagrams, Series Puzzles.

UNIT – 2

6 Hrs

Test of Reasoning – II: - Analogies of numbers and Alphabets completion of blank spaces following the pattern in A: B: C: D relationship odd thing out; Missing number in a sequence or a series.

UNIT – 3

6 Hrs

Arithmetic ability:-Algebraic operations BODMAS, Fractions, Divisibility rules, LCM and GCD (HCF).

Date, Time and Arrangement Problems: Calendar Problems, Clock Problems, Blood Relationship.

UNIT – 4

6 Hrs

Quantitative aptitude: - Averages, Ration and proportion, Problems on ages, Time-distance-speed.

UNIT – 5

6 Hrs

Business computations:- Percentages, Profit & loss, Partnership, simple, compound interest.

Reference Books:

1. Quantitative Aptitude for Competitive Examination by R S Agrawal, S.Chand publications.
2. Quantitative Aptitude and Reasoning by R V Praveen, PHI publishers.
3. Quantitative Aptitude: Numerical Ability (Fully Solved) Objective Questions, Kiran Prakashan, Pratogitaprakasan, Kic X, Kiran Prakasan publishers
4. Quantitative Aptitude for Competitive Examination by Abhijit Guha, Tata Mc Graw hill Publications.
5. Old question Paper of the exams conducted by (Wipro, TCS, Infosys, Etc) at their recruitment process, source-Internet.

**A.G & S.G SIDDHARTHA DEGREE COLLEGE OF ARTS AND SCIENCE
VUYYURU-521165**

(An Autonomous College in the jurisdiction of Krishna University, Machilipatnam)
Accredited with “A” Grade by NAAC, Bengaluru

DEPARTMENT OF MATHEMATICS

Analytical Skills

Time: 2 Hrs

Code: ANS – 301

Max. Marks: 50

Min. Marks: 20

Guidelines for Paper setter

To be set all the questions are “Multiple Choice” with four (or) five options.

Section – A

Unit – 1:- Ten questions. Each question carries **ONE** mark 10x1=10M

Unit – 2:- Ten questions. Each question carries **ONE** mark 10x1=10M

Section – B

Unit – 3:- Five questions. Each question carries **TWO** mark 5x2=10M

Unit – 4:- Five questions. Each question carries **TWO** mark 5x2=10M

Unit – 5:- Five questions. Each question carries **TWO** mark 5x2=10M

A.G &S.G SIDDHARTHA DEGREE COLLEGE, VUYYURU-521165
(An Autonomous College in the jurisdiction of Krishna University, Machilipatnam)

MATHEMATICS MAT-501C 2021-22 III B.Sc (MPC, MPCs, MCCs)

SEMESTER-V

PAPER-V

Max.Marks:70

Hours/ Week: 5

No. of Credits: 5

VECTOR CALCULUS & RING THEORY

UNIT – 1: VECTOR DIFFERENTIATION: - (12 hrs)

Vector Differentiation, Ordinary derivatives of vectors, Differentiability, Gradient, divergence, Curl operators, Formulae Involving these operators.

UNIT – 2: VECTOR INTEGRATION: - (12 hrs)

Line Integral, Surface Integral and Volume integral with examples.

UNIT – 3: VECTOR INTEGRATION APPLICATIONS: - (12 hrs)

Theorems of Gauss and Stokes, Green’s theorem in plane and applications of these theorems.

UNIT – 4: RINGS-I: - (12 hrs)

Definition of Ring and basic properties, Boolean Rings, divisors of zero and cancellation laws Rings, Integral Domains, Division Ring and Fields, The characteristic of a ring – The characteristic of an Integral Domain, The characteristic of a Field. Sub Rings, Ideals

UNIT – 5: RINGS-II: - (12 hrs)

Definition of Homomorphism – Homomorphic Image – Elementary Properties of Homomorphism – Kernel of a Homomorphism – Fundamental theorem of Homomorphism
Maximal Ideals – Prime Ideals.

Reference Books:-

1. Abstract Algebra by J. Fraleigh, Published by Narosa Publishing house.
2. Vector Calculus by Santhi Narayana, Published by S. Chand & Company Pvt. Ltd., New Delhi.
3. A text Book of B.Sc., Mathematics by B.V.S.S.Sarma and others, published by S. Chand & Company Pvt. Ltd., New Delhi.
4. Vector Calculus by R. Gupta, Published by Laxmi Publications.
5. Vector Calculus by P.C. Matthews, Published by Springer Verlag publications.
6. Rings and Linear Algebra by Pundir & Pundir, Published by Pragathi Prakashan.

Suggested Activities:

Seminar/ Quiz/ Assignments/ Project on Ring theory and its applications

Chairman

University Nominee

Subject Expert

Subject Expert

A.G & S.G SIDDHARTHA DEGREE COLLEGE: VUYYURU
(An Autonomous College in the jurisdiction of Krishna University, Machilipatnam)

DEPARTMENT OF MATHEMATICS

Question Paper Guidelines for SEMESTER-END Examinations

Time: 3 Hrs MAT- 501 C Max.Marks:70 Min. Mark: 28

Note :- 1) Answer any FOUR questions out of 8 in Section-A. Each question Carries 5 marks.
(4x5=20 Marks)

2) Answer any FIVE questions out of 8 in Section-B. Each question Carries 10 marks.
(5x10=50 Marks)

Questions to be set as follows:

Questions to be set as follows:

	Unit-1	Unit-2	Unit-3	Unit-4	Unit-5
<u>Section-A</u> (Short Answer Questions)	2	2	1	2	1
<u>Section-B</u> (Essay Questions)	2	1	2	2	1

Chairman

University Nominee

Subject Expert

Subject Expert

-The End -

EXAMINATION AT THE END OF FIFTH SEMESTER (w.e.f 2020-21)

MATHEMATICS Paper VI MAT- 502C MAX.MARKS: 70 TIME: 3 hrs

LINEAR ALGEBRA

Section – A (short answer questions)

Answer any Four of the following questions.

4x5 = 20M

Choosing at least ONE question from each Part.

Part - I

1) Show that the rank of the transpose of a matrix is equal to the rank of the original matrix. i.e., $\rho(A) = \rho(A^T)$.

2) Find the rank of the matrix $\begin{bmatrix} 1 & -2 & 2 & -3 \\ 4 & 1 & 0 & 2 \\ 0 & 3 & 0 & 4 \\ 0 & 1 & 0 & 2 \end{bmatrix}$ by reducing it in the Normal form

3) If S is a subset of a vector space V(F), then prove that S is a subspace of V $\Leftrightarrow L(S) = S$

4) Let w_1 and w_2 be two subspaces of R^4 given by $w_1 = \{(a,b,c,d) ; b-2c+d=0\}$,
 $w_2 = \{(a,b,c,d); a=d, b=2c\}$. Find the basis and dimension (i) w_1 (ii) w_2 (iii) $w_1 \cap w_2$
and hence find the $dim(w_1 + w_2)$

Part - II

5) Let $T: R^2 \rightarrow R^2$ be a linear transformation defined by $T(1,0)=(1,1), T(0,1)=(-1,2)$ then find a linear transformation T

6) The mapping $T: V_3(R) \rightarrow V_2(R)$ is defined by $T(x, y, z) = (x - y, x - z)$ is a linear transformation.

- 7) State and prove Cauchy – Schwarz’s inequality
- 8) State and prove Triangle inequality

Section – B (long answer questions)

Answer any **FIVE** of the following questions.

5x10 = 50M

Choosing at least TWO questions from each Part.

Part - I

- 9) State and prove Cayley – Hamilton theorem in Matrices.
- 10) Find the characteristic roots and the corresponding characteristic vectors of the matrix

$$A = \begin{bmatrix} 1 & 4 \\ 3 & 2 \end{bmatrix}$$

- 11) Let $V(F)$ be a vector space. A non-empty set $W \subseteq V$. The necessary and sufficient condition for W to be a subspace of V is $a, b \in F$ and $\alpha, \beta \in V \Rightarrow a\alpha + b\beta \in W$
- 12) Let W be a subspace of a finite dimensional vector space $V(F)$ then

$$\dim V/W = \dim V - \dim W.$$

Part - II

- 13) Find the linear Transformation $T(x, y, z)$ where $T : R^3 \rightarrow R$ is defined by
 $T(1, 1, 1) = 3, T(0, 1, -2) = 1$ and $T(0, 0, 1) = -2.$
- 14) State and prove Rank-nullity theorem
- 15) State and prove Bessel’s inequality
- 16) If $(1, 0, 1, 1) (-1, 0, -1, 1) (0, -1, 1, 1)$ forms a basis of a subspace of $R^4(R)$ use Gram-Schmidt process to obtain an orthonormal basis.

Chairman

University Nominee

Subject Expert

Subject Expert

A.G & S.G SIDDHARTHA DEGREE COLLEGE: VUYYURU-521165

(An Autonomous College in the jurisdiction of Krishna University, Machilipatnam)

MATHEMATICS MAT-502C 2021-22 III B.Sc (MPC, MPCs, MCCs)

SEMESTER-V

PAPER-VI

Max.Marks:70

Hours/ Week: 5

No. of Credits: 5

LINEAR ALGEBRA

UNIT –I Matrix:

(12 hrs)

Matrices, Elementary Properties of Matrices, Triangular form, Echelon form, Normal form Inverse Matrices, Non – Singular form, Rank of Matrix, Linear Equations, Characteristic Roots, Characteristic Vectors of square Matrix, Cayley – Hamilton Theorem.

UNIT – II Vector Spaces-I:

(12 hrs)

Vector Spaces, General properties of vector spaces, n-dimensional Vectors, addition and scalar multiplication of Vectors, internal and external composition, Null space, Vector subspaces, Algebra of subspaces, Linear Sum of two subspaces, linear combination of Vectors, Linear span Linear independence and Linear dependence of Vectors.

UNIT –III Vector Spaces-II:

(12 hrs)

Basis of Vector space, Finite dimensional Vector spaces, basis extension, co-ordinates, Dimension of a Vector space, Dimension of a subspace, Quotient space and Dimension of Quotient space.

UNIT –IV Linear Transformations:

(12 hrs)

Linear transformations, linear operators, Properties of L.T, sum and product of LTs, Algebra of Linear Operators, Range and null space of linear transformation, Rank and Nullity of linear transformations – Rank – Nullity Theorem.

UNIT –V Inner product space:

(12 hrs)

Inner product spaces, Euclidean and unitary spaces, Norm or length of a Vector, Schwartz inequality, Triangle in Inequality, Parallelogram law, Orthogonality, Orthonormal set, complete orthonormal set, Gram – Schmidt orthogonalisation process. Bessel's inequality and Parseval's Identity.

Reference Books:

1. Linear Algebra by J.N. Sharma and A.R. Vasista, published by Krishna Prakashan Mandir, Meerut- 250002.
2. Matrices by Shanti Narayana, published by S.Chand Publications.
3. Linear Algebra by Kenneth Hoffman and Ray Kunze, published by Pearson Education (low priced edition), New Delhi.
4. Linear Algebra by Stephen H. Friedberg et al published by Prentice Hall of India Pvt. Ltd. 4th Edition 2007.

Suggested Activities:

Seminar/ Quiz/ Assignments/ Project on “Applications of Linear algebra Through Computer Sciences”

Chairman

University Nominee

Subject Expert

Subject Expert

A.G & S.G SIDDHARTHA DEGREE COLLEGE: VUYYURU
(An Autonomous College in the jurisdiction of Krishna University, Machilipatnam)

DEPARTMENT OF MATHEMATICS

Question Paper Guidelines for SEMESTER-END Examinations

Time: 3 Hrs MAT- 502 C Max.Marks:70 Min. Mark: 28

Note :- 1) Answer any FOUR questions out of 8 in Section-A. Each question Carries 5 marks. (4x5=20 Marks)

2) Answer any FIVE questions out of 8 in Section-B. Each question Carries 10 marks. (5x10=50 Marks)

Questions to be set as follows:

Questions to be set as follows:

	Unit-1	Unit-2	Unit-3	Unit-4	Unit-5
<u>Section-A</u> (Short Answer Questions)	2	1	1	2	2
<u>Section-B</u> (Essay Questions)	2	1	1	2	2

Chairman

University Nominee

Subject Expert

Subject Expert

-The End -

**A.G & S.G SIDDHARTHA DEGREE COLLEGE OF ARTS AND SCIENCE,
VUYYURU – 521165, KRISHNA Dt., A.P.
(An Autonomous College in the jurisdiction of Krishna University, Machilipatnam)
EXAMINATION AT THE END OF FIFTH SEMESTER (w.e.f 2020-21)**

MATHEMATICS Paper V MAT- 501C MAX.MARKS: 70 TIME: 3 hrs

(VECTOR CALCULUS AND RING THEORY)

Section – A (short answer questions)

Answer any **Four** of the following questions.

4x5 = 20M

Choosing at least **ONE** question from each Part.

Part - I

- 1) If $r = a \cos t i + a \sin t j + at \tan \theta k$ find $\left| \frac{dr}{dt} \times \frac{d^2r}{dt^2} \right|$ and $\left[\frac{dr}{dt} \frac{d^2r}{dt^2} \frac{d^3r}{dt^3} \right]$
- 2) Find $\text{div } f$ and $\text{curl } f$ where $f = \text{grad}(x^3 + y^3 + z^3 - 3xyz)$.
- 3) If $F = 3xyi - y^2j$ evaluate $\oint_c F \cdot dr$ where 'c' is the curve $y = 2x^2$ in the xy plane from (0, 0) to (1, 2).
- 4) If $F = 2xzi - xj + y^2k$ evaluate the $\int_v F \cdot dv$ where v is the region bounded by the surface $x = 0, x = 2, y = 0, y = 6, z = x^2, z = 4$.

Part - II

- 5) State and prove Green's theorem in a plane.
- 6) Prove that $Z_m = \{0, 1, 2, 3, \dots, m-1\}$ is a ring with respect to addition and multiplication modulo 'm'
- 7) Prove that a field has no Zero divisors.
- 8) If f is homomorphism of a ring R into a ring R^1 then $\text{ker } f$ is an ideal of R

Chairman

University Nominee

Subject Expert

Subject Expert

Section – B (long answer questions)

Answer any **FIVE** of the following questions.

5x10 = 50M

Choosing at least TWO questions from each Part.

Part - I

- 9) Prove that $\text{grad}(A \cdot B) = (B \cdot \nabla)A + (A \cdot \nabla)B + B \times \text{curl} A + A \times \text{curl} B$.
- 10) Evaluate $\int_s F \cdot N ds$ where $F = zi + xj - 3y^2zk$ and s is the surface $x^2 + y^2 = 16$ included in the first octant between $z=0$ and $z=5$.
- 11) State and prove Gauss divergence Theorem.
- 12) Verify Green's Theorem in the plane for $\oint_c (3x^2 - 8y^2)dx + (4y - 6xy)dy$ where c is the region bounded by $y = \sqrt{x}$ and $y = x^2$.

Part - II

- 13) Find the directional derivative of the function $f = x^2 - y^2 + 2z^2$ at the point $P(1, 2, 3)$ in the direction of the line PQ where $Q = (5, 0, 4)$.
- 14) Define Field. Prove that every field is an integral domain.
- 15) Prove that $Q(\sqrt{2}) = \{a + b\sqrt{2} / a, b \in Q\}$ is a ring with respect to ordinary addition and multiplication.
- 16) State and prove fundamental theorem of ring homomorphism.

Chairman

University Nominee

Subject Expert

Subject Expert

**A.G& S.G.SIDDHARTHA DEGREE COLLEGE OF ARTS &
SCIENCE**

VUYYURU-521165, KRISHNA Dt., A.P.(Autonomous)

Accredited by NAAC with "A" Grade

2021-2022



DEPARTMENT OF MATHEMATICS

MINUTES OF BOARD OF STUDIES

EVEN SEMESTER

30-03-2022

Minutes of the meeting of BOS in Mathematics for B.Sc Degree Courses of
AG & SG Siddhartha Degree College of Arts & Science, Vuyuru, held at
2.30PM on 30 - 03 - 2022 through online.

N.V. Srinivasa Rao

Presiding

Members Present:

- | | | |
|--|-----------------------|---|
| 1) <u>N.V. Srinivasa Rao</u>
(N.V. Srinivasa Rao) | Chairman | Head, Department of
Mathematics,
AG & SG S Degree College. |
| 2) _____
(Dr. K. Jaya Lakshmi) | University
Nominee | Department of Mathematics,
Krishna University,
Machilipatnam. |
| 3) _____
(M. Venkateswara Rao) | Subject
Expert | Department of Mathematics,
Govt. Degree College,
Avanigadda. |
| 4) _____
(I. V. Venkateswara Rao) | Subject
Expert | Department of Mathematics,
P. B. Siddhartha College,
Vijayawada |
| 5) <u>D. Sunitha</u>
(D. Sunitha) | Member | Lecturer in Mathematics
AG & SG S Degree College. |
| 6) <u>A. Bhargavi</u>
(A. Bhargavi) | Member | Lecturer in Mathematics
AG & SG S Degree College. |
| 7) <u>Noor Mohammad</u>
(Noor Mohammad) | Member | Lecturer in Mathematics
AG & SG S Degree College. |
| 8) <u>K. Rajya Lakshmi</u>
(K. Rajya Lakshmi) | Member | Lecturer in Mathematics
AG & SG S Degree College. |
| 9) <u>B. Durga Praveen</u>
(B. Durga Praveen) | Student
Member | III B.Sc M.C.Cs
AG & SG S Degree College. |
| 10) <u>M. Rose Manasa</u>
(M. Rose Manasa) | Student
Member | III B.Sc M.P.C (E)
AG & SG S Degree College. |

Agenda of B.O.S Meeting:

1. To discuss and recommend the Syllabi, Model Question Papers and Guidelines to be followed by question paper setters in Mathematics for 2nd Semester as per the guidelines and instructions under CBCS prescribed by Krishna University from the Academic Year 2021-22.
2. To discuss and recommend the Syllabi, Model Question Papers and Guidelines to be followed by question paper setters in Mathematics for 4th Semester as per the guidelines and instructions under CBCS prescribed by Krishna University from the Academic Year 2021-22.
3. To discuss and recommend the Syllabi, Model Question Papers and Guidelines to be followed by question paper setters in Mathematics for 6th Semester as per the guidelines and instructions under CBCS prescribed by Krishna University from the Academic Year 2021-22.
4. Any other matter.

Resolutions.

1. Discussed and recommended that changes are required in Syllabi, Model Question Papers, Guidelines to be followed by the question paper setters in Mathematics for 2nd Semesters from Academic year 2021-22. The maximum marks for IA is 25 and SE is 75. Each IA written examination is of 1 Hr. duration for 15 marks. The tests will be conducted centrally. The average of two such IA is calculated for 15 marks. 5 marks will be allotted basing on Assignment. 5 marks will be allotted basing on performance of seminar, group discussion, surprise tests etc. There is no minimum passing for IA and there is no provision for improvement in IA. Even though the candidate is absent for two IA exams/obtain zero marks the external marks are considered (if he/ she gets out of 75) and the result shall be declared as 'PASS' from the Academic year 2021-22.
2. Discussed and recommended that changes are required in Syllabi, Model Question Papers, Guidelines to be followed by the question paper setters in Mathematics of 4th Semesters from Academic year 2021-22. The maximum marks for IA is 30 and SE is 70. Each IA written examination is of 1 Hr. 30 min duration for 20 marks. The tests will be conducted centrally. The average of two such IA is calculated for 20 marks. 5 marks will be allotted basing on Assignment. 5 marks are allotted for attendance. There is no minimum passing for IA and there is no provision for improvement in IA. Even though the candidate is absent for two IA exams/obtain zero marks external marks are considered (if he/ she gets 40 out of 70) and the result shall be declared as 'PASS' from the Academic year 2021-22.
3. Discussed and recommended that no changes are required in syllabi, Model Question Papers, Guidelines for question paper setters in Mathematics for the 6th Semester for the Academic year 2021-22.
4. Discussed and recommended for organizing seminars, Guest lecturers, Online Examinations, Workshops to upgrade the knowledge of students for Competitive Examinations for the approval of the Academic Council.

N.V. [Signature]
Chairman

A. G & S. G Siddhartha Degree College of Arts and Science (Autonomous), Vuyyuru

(An Autonomous College in the jurisdiction of Krishna University, Machilipatnam)

NAAC reaccruited at 'A' level

Autonomous -ISO 9001 – 2015 Certified

Title of the Paper: REAL ANALYSIS

Semester: II

Course Code	MAT T21B	Course Delivery Method	Class Room / Blended Mode - Both
Credits	5	CIA Marks	25
No. of Lecture Hours / Week	6	Semester End Exam Marks	75
Total Number of Lecture Hours	75	Total Marks	100
Year of Introduction :2021-22	Year of Offering: 2021 - 22	Year of Revision: ----	Percentage of Revision: 0%

Course Outcomes:

After successful completion of this course, the student will be able to

1. Get clear idea about the real numbers and real valued functions.
2. Obtain the skills of analyzing the concepts and applying appropriate methods for testing convergence of a sequence/ series.
3. Test the continuity and differentiability and Riemann integration of a function.
4. Know the geometrical interpretation of mean value theorems.

Course Syllabus:

UNIT – I (12 Hours) REAL NUMBERS:

The algebraic and order properties of \mathbb{R} , Absolute value and Real line, Completeness property of \mathbb{R} , Applications of supremum property; intervals. (No question is to be set from this portion).

Real Sequences:

Sequences and their limits, Range and Boundedness of Sequences, Limit of a sequence and Convergent sequence. The Cauchy's criterion, properly divergent sequences, Monotone sequences, Necessary and Sufficient condition for Convergence of Monotone Sequence, Limit Point of Sequence, Subsequences and the Bolzano-weierstrass theorem – Cauchy Sequences – Cauchy's general principle of convergence theorem.

UNIT –II (12 Hours) INFINITE SERIES:

Series: Introduction to series, convergence of series. Cauchy's general principle of convergence for series tests for convergence of series, Series of Non-Negative Terms.

1. P-test
2. Cauchy's n^{th} root test or Root Test.
3. D'Alembert's Test or Ratio Test.
4. Alternating Series – Leibnitz Test.

Absolute convergence and conditional convergence.

UNIT – III (12 Hours) CONTINUITY :

Limits : Real valued Functions, Bounded ness of a function, Limits of functions. Some extensions of the limit concept, Infinite Limits. Limits at infinity. (No question is to be set from this portion).

Continuous functions: Continuous functions, Combinations of continuous functions, Continuous Functions on intervals, uniform continuity.

UNIT – IV (12 Hours) DIFFERENTIATION AND MEAN VALUE THEORMS:

The derivability of a function, on an interval, at a point, Derivability and continuity of a function, Graphical meaning of the Derivative, Mean value Theorems; Rolle's Theorem, Lagrange's Theorem, Cauchy's Mean value Theorem

UNIT – V (12 Hours) RIEMANN INTEGRATION :

Riemann Integral, Riemann integral functions, Darboux theorem. Necessary and sufficient condition for R – integrability, Properties of integrable functions, Fundamental theorem of integral calculus, integral as the limit of a sum, Mean value Theorems.

Co-Curricular Activities(15 Hours)

Seminar/ Quiz/ Assignments/ Real Analysis and its applications / Problem Solving.

Text Book:

Introduction to Real Analysis by Robert G.Bartle and Donlad R. Sherbert, published by John Wiley.

Reference Books:

1. A Text Book of B.Sc Mathematics by B.V.S.S. Sarma and others, published by S. Chand & Company Pvt. Ltd., New Delhi.
2. Elements of Real Analysis as per UGC Syllabus by Shanthi Narayan and Dr. M.D.Raisinghania, published by S. Chand & Company Pvt. Ltd., New Delhi.

A . G & S . G Siddhartha Degree College of Arts and Science (Autonomous), Vuyyuru

(An Autonomous College in the jurisdiction of Krishna University, Machilipatnam)

SEMESTER – II , REAL ANALYSIS

B.Sc MATHEMATICS MODEL PAPER

Time: 3Hrs

Max.Marks:75M

SECTION - A

Answer any FIVE questions. Each question carries FIVE marks.

5x5 = 25M

- 1.
- 2.
- 3.
- 4.
- 5.
- 6.
- 7.
- 8.

SECTION - B

Answer ALL the questions. Each question carries TEN marks.

5 X 10 M = 50 M

9. a) OR b)
10. a) OR b)
11. a) OR b)
12. a) OR b)
13. a) OR b)

BLUE PRINT FOR QUESTION PAPER PATTERN COURSE-IV, REAL ANALYSIS

Unit	TOPIC	S.A.Q	E.Q	Total Marks
I	Real Number System and Real Sequence	1	2	25
II	Infinite Series	1	2	25
III	Limits and Continuity	2	2	30
IV	Differentiation and Mean Value Theorem	2	2	30
V	Riemann Integration	2	2	30
	TOTAL	8	10	140

S.A.Q. = Short answer questions (5 marks)

E.Q. = Essay questions (10 marks)

Short answer questions : 5 X 5 M = 25 M

Essay questions : 5 X 10 M = 50 M

Total Marks = 75 .

A. G & S. G Siddhartha Degree College of Arts and Science (Autonomous), Vuyyuru

(An Autonomous College in the jurisdiction of Krishna University, Machilipatnam)

NAAC reaccredited at 'A' level

Autonomous -ISO 9001 – 2015 Certified

Title of the Paper: REAL ANALYSIS

Semester: IV

Course Code	MAT - 401	Course Delivery Method	Class Room / Blended Mode - Both
Credits	5	CIA Marks	30
No. of Lecture Hours / Week	6	Semester End Exam Marks	70
Total Number of Lecture Hours	75	Total Marks	100
Year of Introduction :2021-22	Year of Offering: 2022 - 23	Year of Revision: ----	Percentage of Revision: 0%

Course Outcomes:

After successful completion of this course, the student will be able to

1. Get clear idea about the real numbers and real valued functions.
2. Obtain the skills of analyzing the concepts and applying appropriate methods fortesting convergence of a sequence/ series.
3. Test the continuity and differentiability and Riemann integration of a function.
4. Know the geometrical interpretation of mean value theorems.

Course Syllabus:

UNIT – I (12 Hours) REAL NUMBERS:

The algebraic and order properties of R, Absolute value and Real line, Completeness property of R, Applications of supremum property; intervals. (No question is to be set from this portion).

Real Sequences:

Sequences and their limits, Range and Boundedness of Sequences, Limit of a sequence and Convergent sequence. The Cauchy's criterion, properly divergent sequences, Monotone sequences, Necessary and Sufficient condition for Convergence of Monotone Sequence, Limit Point of Sequence, Subsequences and the Bolzano-weierstrass theorem – Cauchy Sequences – Cauchy's general principle of convergence theorem.

UNIT –II (12 Hours) INFINITIE SERIES:

Series: Introduction to series, convergence of series. Cauchy's general principle of convergence for series tests for convergence of series, Series of Non-Negative Terms.

1. P-test
2. Cauchy's n^{th} root test or Root Test.
3. D'-Alembert's Test or Ratio Test.
4. Alternating Series – Leibnitz Test.

Absolute convergence and conditional convergence.

UNIT – III (12 Hours) CONTINUITY :

Limits : Real valued Functions, Bounded ness of a function, Limits of functions. Some extensions of the limit concept, Infinite Limits. Limits at infinity. (No question is to be set from this portion).

Continuous functions: Continuous functions, Combinations of continuous functions, Continuous Functions on intervals, uniform continuity.

UNIT – IV (12 Hours) DIFFERENTIATION AND MEAN VALUE THEORMS:

The derivability of a function, on an interval, at a point, Derivability and continuity of a function, Graphical meaning of the Derivative, Mean value Theorems; Rolle's Theorem, Lagrange's Theorem, Cauchy's Mean value Theorem

UNIT – V (12 Hours) RIEMANN INTEGRATION :

Riemann Integral, Riemann integral functions, Darboux theorem. Necessary and sufficient condition for R – integrability, Properties of integrable functions, Fundamental theorem of integral calculus, integral as the limit of a sum, Mean value Theorems.

Co-Curricular Activities(15 Hours)

Seminar/ Quiz/ Assignments/ Real Analysis and its applications / Problem Solving.

Text Book:

Introduction to Real Analysis by Robert G.Bartle and Donlad R. Sherbert, published by John Wiley.

Reference Books:

1. A Text Book of B.Sc Mathematics by B.V.S.S. Sarma and others, published by S. Chand & Company Pvt. Ltd., New Delhi.
2. Elements of Real Analysis as per UGC Syllabus by Shanthi Narayan and Dr. M.D. Raisinghania, published by S. Chand & Company Pvt. Ltd., New Delhi.

A . G & S . G Siddhartha Degree College of Arts and Science (Autonomous), Vuyuru

(An Autonomous College in the jurisdiction of Krishna University, Machilipatnam)

SEMESTER – IV , REAL ANALYSIS

B.Sc MATHEMATICS MODEL PAPER

Time: 3Hrs

Max.Marks:70M

SECTION - A

Answer any FOUR questions. Each question carries FIVE marks.

Choosing at least ONE question from each part.

4 X 5 M=20 M.

Part – 1

1. Unit - I
2. Unit - II
3. Unit - II
4. Unit - III

Part – 2

5. Unit - IV
6. Unit - IV
7. Unit - V
8. Unit - V

SECTION - B

Answer any FIVE questions. Each question carries TEN marks.

Choosing at least TWO question from each part

5 X 10 M = 50 M

Part – 1

9. Unit - I
10. Unit - II
11. Unit - II
12. Unit - III

Part – 2

13. Unit - IV
14. Unit - IV
15. Unit - V
16. Unit - V

BLUE PRINT FOR QUESTION PAPER PATTERN COURSE-IV, REAL ANALYSIS

Unit	TOPIC	S.A.Q	E.Q	Total Marks
I	Real Number System and Real Sequence	1	1	15
II	Infinite Series	2	2	30
III	Limits and Continuity	1	1	15
IV	Differentiation and Mean Value Theorem	2	2	30
V	Riemann Integration	2	2	30
	TOTAL	8	8	120

S.A.Q. = Short answer questions (5 marks)

E.Q. = Essay questions (10 marks)

Short answer questions : $4 \times 5 \text{ M} = 20 \text{ M}$

Essay questions : $5 \times 10 \text{ M} = 50 \text{ M}$

Total Marks = 70 .

A. G & S. G Siddhartha Degree College of Arts and Science (Autonomous), Vuyyuru

(An Autonomous College in the jurisdiction of Krishna University, Machilipatnam)

NAAC reaccredited at 'A' level

Autonomous -ISO 9001 – 2015 Certified

Title of the Paper : LINEAR ALGEBRA

Semester: IV

Course Code	MAT - 402	Course Delivery Method	Class Room / Blended Mode - Both
Credits	5	CIA Marks	30
No. of Lecture Hours / Week	6	Semester End Exam Marks	70
Total Number of Lecture Hours	75	Total Marks	100
Year of Introduction :2021-22	Year of Offering: 2022 - 23	Year of Revision: ----	Percentage of Revision: 0%

Course Outcomes:

After successful completion of this course, the student will be able to;

1. Understand the concepts of vector spaces, subspaces, basis, dimension and their properties
2. Understand the concepts of linear transformations and their properties
3. Apply Cayley- Hamilton theorem to problems for finding the inverse of a matrix and higher powers of matrices without using routine methods
4. Learn the properties of inner product spaces and determine orthogonality in inner product spaces.

Course Syllabus:

UNIT – I (12 Hours) Vector Spaces-I:

Vector Spaces, General properties of vector spaces, n-dimensional Vectors, addition and scalar multiplication of Vectors, internal and external composition, Null space, Vector subspaces, Algebra of subspaces, Linear Sum of two subspaces, linear combination of Vectors, Linear span Linear independence and Linear dependence of Vectors.

UNIT –II (12 Hours) Vector Spaces-II:

Basis of Vector space, Finite dimensional Vector spaces, basis extension, co-ordinates, Dimension of a Vector space, Dimension of a subspace, Quotient space and Dimension of Quotient space.

UNIT –III (12 Hours) Linear Transformations:

Linear transformations, linear operators, Properties of L.T, sum and product of LTs, Algebra of Linear Operators, Range and null space of linear transformation, Rank and Nullity of linear transformations – Rank – Nullity Theorem.

UNIT –IV (12 Hours) Matrix :

Matrices, Elementary Properties of Matrices, Inverse Matrices, Rank of Matrix, Linear Equations, Characteristic equations, Characteristic Values & Vectors of square matrix, Cayley – Hamilton Theorem.

UNIT –V (12 Hours) Inner product space:

Inner product spaces, Euclidean and unitary spaces, Norm or length of a Vector, Schwartz inequality, Triangle Inequality, Parallelogram law, Orthogonality, Orthonormal set, complete orthonormal set, Gram – Schmidt orthogonalization process. Bessel's inequality and Parseval's Identity.

Co-Curricular Activities (15 Hours)

Seminar/ Quiz/ Assignments/ Linear algebra and its applications / Problem Solving.

Text Book:

Linear Algebra by J.N. Sharma and A.R. Vasista, published by Krishna Prakashan Mandir, Meerut- 250002.

Reference Books :

1. Matrices by Shanti Narayana, published by S.Chand Publications.
2. Linear Algebra by Kenneth Hoffman and Ray Kunze, published by Pearson Education (low priced edition), New Delhi.
3. Linear Algebra by Stephen H. Friedberg et. al. published by Prentice Hall of India Pvt. Ltd. 4th Edition, 2007.

A . G & S . G Siddhartha Degree College of Arts and Science (Autonomous), Vuyuru

(An Autonomous College in the jurisdiction of Krishna University, Machilipatnam)

SEMESTER – IV , LINEAR ALGEBRA

B.Sc MATHEMATICS MODEL PAPER

Time: 3Hrs

Max.Marks:70M

SECTION - A

Answer any FOUR questions. Each question carries FIVE marks.

Choosing at least ONE question from each part.

4 X 5 M=20 M.

Part – 1

1. Unit - I
2. Unit - II
3. Unit - III
4. Unit - III

Part – 2

5. Unit - IV
6. Unit - IV
7. Unit - V
8. Unit - V

SECTION - B

Answer any FIVE questions. Each question carries TEN marks.

Choosing at least TWO question from each part

5 X 10 M = 50 M

Part – 1

9. Unit - I
10. Unit - II
11. Unit - III
12. Unit - III

Part – 2

13. Unit - IV
14. Unit - IV
15. Unit - V
16. Unit - V

BLUE PRINT FOR QUESTION PAPER PATTERN COURSE-V, LINEAR ALGEBRA

Unit	Topic	S.A.Q	E.Q	Total Marks
I	Vector spaces - I	1	1	15
II	Vector spaces - II	1	1	15
III	Linear Transformation	2	2	30
IV	Matrix	2	2	30
V	Inner product spaces	2	2	30
Total		8	8	120

S.A.Q. = Short answer questions (5 marks)

E.Q. = Essay questions (10 marks)

Short answer questions : $4 \times 5 \text{ M} = 20 \text{ M}$

Essay questions : $5 \times 10 \text{ M} = 50 \text{ M}$

Total Marks = 70 M

A.G & S.G SIDDHARTHA DEGREE COLLEGE: VUYYURU-521165
(An Autonomous College in the jurisdiction of Krishna University, Machilipatnam)
Accredited with “A” Grade by NAAC, Bengaluru

MATHEMATICS	MAT-601GE	w.e.f.2020-21	III B.Sc
--------------------	------------------	----------------------	-----------------

SEMESTER-VI	PAPER-VII	Max.Marks:70
Hours/ Week: 5		No.of Credits: 5

ELECTIVE-VII-(B); NUMERICAL ANALYSIS

UNIT- I:	10 hours
-----------------	-----------------

Errors in Numerical computations: Errors and their Accuracy, Mathematical Preliminaries, Errors and their Analysis, Absolute, Relative and Percentage Errors, A general error formula, Error in a series approximation.

UNIT – II:	12 hours
-------------------	-----------------

Solution of Algebraic and Transcendental Equations: The bisection method, the iteration method, the method of false position, Newton Raphson method, Generalized Newton Raphson method.

UNIT – III:	12 hours
--------------------	-----------------

Finite Differences and Interpolation: Errors in polynomial interpolation, Finite Differences, Forward differences, Backward differences, Symbolic relations, Detection of errors by use of Differences Tables, Differences of a polynomial, Newton’s formulae for interpolation

UNIT – IV:	12 hours
-------------------	-----------------

Central Differences: Central Differences, Central Difference Interpolation Formulae, Gauss’s central difference formulae, Stirling’s central difference formula, Bessel’s Formula, Everett’s Formula.

UNIT – V:	14 hours
------------------	-----------------

Interpolation – III:

Interpolation with unevenly spaced points, Lagrange’s formula, Error in Lagrange’s formula, Divided differences and their properties, Relation between divided differences and forward differences, Relation between divided differences and backward differences Relation between divided differences and central differences, Newton’s general interpolation Formula, Inverse interpolation.

Reference Books:

1. Numerical Analysis by S.S.Sastry, published by Prentice Hall of India Pvt. Ltd., New Delhi. (Latest Edition)
2. Numerical Analysis by G. SankarRao published by New Age International Publishers, New – Hyderabad.
3. Finite Differences and Numerical Analysis by H.C Saxena published by S. Chand and Company, Pvt. Ltd., New Delhi.
4. Numerical methods for scientific and engineering computation by M.K.Jain, S.R.K.Iyengar, R.K. Jain.

Suggested Activities:

Seminar/ Quiz/ Assignments

A.G & S.G SIDDHARTHA DEGREE COLLEGE OF ARTS AND SCIENCE,
VUYYURU – 521165, KRISHNA Dt., A.P.
(An Autonomous College in the jurisdiction of Krishna University, Machilipatnam)
Accredited with “A” Grade by NAAC, Bengaluru
EXAMINATION AT THE END OF SIXTH SEMESTER (w.e.f 2020-21)

MATHEMATICS Paper VII MAT- 601GE MAX.MARKS: 70 TIME: 3 hrs

ELECTIVE–VII-(B):NUMERICAL ANALYSIS

Section – A (short answer questions)

Answer any Four of the following questions.

4x5 = 20M

Choosing at least ONE question from each Part.

PART - I

1. Evaluate the sum $S = \sqrt{3} + \sqrt{5} + \sqrt{7}$ to four significant digits and find its absolute and relative errors.
2. Find the real root of the equation $x^3 + x - 1 = 0$ by Iteration method, given that the root lies near 1
3. Find the real root of the equation $x \log_{10} x = 1.2$ by Newton – Raphson method
4. Prove that $e^x = \left(\frac{\Delta^2}{E}\right) e^{x \frac{Ee^x}{\Delta^2 e^x}}$ the interval of differencing being unity.

PART - II

5. If $u_0 = 3, u_1 = 12, u_2 = 81, u_3 = 200, u_4 = 100, u_5 = 8$ find the value of $\Delta^5 u_0$
6. Prove that i) $\mu^2 = 1 + \frac{1}{4} \delta^2$ ii) $\Delta = \frac{1}{2} \delta^2 + \delta \sqrt{1 + \frac{1}{4} \delta^2}$
7. Apply Gauss’s Forward formula to find the value of u_9 if $u_0 = 14, u_4 = 24, u_8 = 32, u_{12} = 35, u_{16} = 40$
8. Find the third divided difference for the function $f(x) = x^3 + x + 2$ for the arguments 1, 3, 6, 11

Section – B (long answer questions)

Answer any FIVE of the following questions.

5x10 = 50M

Choosing at least TWO question from each Part.

PART - I

9. If $U = 5xy^2 / z^3$ then find relative maximum error in U, given that $\Delta x = \Delta y = \Delta z = 0.001$ and $x = y = z = 1$
10. Find the real root of the equation $x^2 - 4x - 10 = 0$ by bisection method.
11. Find the real root of the equation $x^3 - 2x - 5 = 0$ by Regula – Falsi method.
12. State and prove Newton’s Gregory forward interpolation formula

PART - II

13. The following table gives the marks obtained by 100 students in Mathematics in a certain examination

Marks obtained: 30-40 40-50 50-60 60-70 70-80

No.of Students: 25 35 22 11 7

How many students got more than 55 marks.

14. The population of town is as follows. Find the population for the year 1956 by Gauss's Backward formula from the following table

Year : 1931 1941 1951 1961 1971

Population : 15 20 27 39 52
(in thousand)

15. State and prove Stirling's formula
16. State and prove Newton's Divided difference formula

A.G & S.G SIDDHARTHA DEGREE COLLEGE: VUYYURU-521165

(An Autonomous College in the jurisdiction of Krishna University, Machilipatnam)

Accredited with "A" Grade by NAAC, Bengaluru

MATHEMATICS	MAT-602CE	w.e.f.2020-21	III B.Sc
-------------	-----------	---------------	----------

SEMESTER-VI

PAPER-VIII

Max.Marks:70

Hours/ Week: 5

No.of Credits: 5

Cluster Elective- VIII-A-1: INTEGRAL TRANSFORMS

UNIT-1:Application of Laplace Transform to solutions of Differential Equations 12 hrs

Solutions of ordinary Differential Equations. Solutions of Differential Equations with constants co-efficient Solutions of Differential Equations with Variable co-efficient

UNIT – 2:Application of Laplace Transform : - 12 hrs

Solution of simultaneous ordinary Differential Equations.Solutions of partial Differential Equations.

UNIT – 3:Application of Laplace Transforms to Integral Equations : - 12 hrs

Integral Equations-Abel's, Integral Equation-Integral Equation of Convolution Type, Integro Differential Equations. Application of L.T. to Integral Equations.

UNIT –4: Fourier Transforms-I : - 12 hrs

Definition of Fourier Transform – Fourier's sine Transform – Fourier cosine Transform – Linear Property of Fourier Transform – Change of Scale Property for Fourier Transform – sine Transform and cosine transform shifting property – modulation theorem.

UNIT – 5: Fourier Transform-II : - 12 hrs

Convolution Definition – Convolution Theorem for Fourier transform – parseval's Identify Relationship between Fourier and Laplace transforms – problems related to Integral Equations.

Finte Fourier Transforms : -

Finte Fourier Sine Transform – Finte Fourier Cosine Transform – Inversion formula for sine and cosine Transforms only statement and related problems.

Reference Books :-

1. Integral Transforms by A.R. Vasistha and Dr. R.K. Gupta Published by Krishna Prakashan Media Pvt. Ltd. Meerut.
2. A Course of Mathematical Analysis by ShanthiNarayana and P.K. Mittal, Published by S. Chand and Company pvt. Ltd., New Delhi.
3. Fourier Series and Integral Transforms by Dr. S. Sreenadh Published by S.Chand and Company Pvt. Ltd., New Delhi.
4. Lapalce and Fourier Transforms by Dr. J.K. Goyal and K.P. Gupta, Published by Pragathi Prakashan, Meerut.
5. Integral Transforms by M.D. Raising hania, - H.C. Saxsena and H.K. Dass Published by S.Chand and Company pvt. Ltd., New Delhi.

Suggested Activities:

Seminar/ Quiz/ Assignments

A.G & S.G SIDDHARTHA DEGREE COLLEGE: VUYYURU-521165

(An Autonomous College in the jurisdiction of Krishna University, Machilipatnam)

Accredited with "A" Grade by NAAC, Bengaluru

MATHEMATICS	MAT-603CE	w.e.f.2020-21	III B.Sc
--------------------	------------------	----------------------	-----------------

SEMESTER-VI	PAPER-VIII	Max.Marks:70
--------------------	-------------------	---------------------

Hours/ Week: 5

No.of Credits: 5

ELECTIVE – VIII-A-2: ADVANCED NUMERICAL ANALYSIS

Unit – I Curve Fitting: 10 Hours

Least – Squares curve fitting procedures, fitting a straight line, Polynomial fitting, Curve fitting by a power functions and exponential function.

UNIT- II Numerical Differentiation: 12 hours

Derivatives using Newton's forward difference formula, Newton's backward difference formula, Derivatives using central difference formula, Stirling's interpolation formula, Newton's divided difference formula, Maximum and minimum values of a tabulated function.

UNIT- III Numerical Integration: 12 hours

General quadrature formula, Trapezoidal rule, Simpson's 1/3 – rule, Simpson's 3/8 – rule, Boole's rule and Weddle's rules (only problems),

UNIT – IV Solutions of simultaneous Linear Systems of Equations: 14 hours

Solution of linear systems – Direct methods, Matrix inversion method, Gaussian elimination methods, Gauss-Jordan Method, Method of factorization. Iterative methods – Jacobi's method, Gauss-Seidel method.

UNIT – V Numerical solution of ordinary differential equations: 12 Hours

Introduction, Solution by Taylor's Series, Picard's method of successive approximations, Euler's method, Modified Euler's method, Runge – Kutta methods.

Reference Books :

1. Numerical Analysis by S.S.Sastry, published by Prentice Hall India (Latest Edition).
2. Numerical Analysis by G. SankarRao, published by New Age International Publishers, Hyderabad.
3. Finite Differences and Numerical Analysis by H.C Saxena published by S. Chand and Company, Pvt. Ltd., New Delhi.
4. Numerical methods for scientific and engineering computation by M.K.Jain, S.R.K.Iyengar, R.K. Jain.

Suggested Activities:

Seminar/ Quiz/ Assignments

A.G & S.G SIDDHARTHA DEGREE COLLEGE: VUYYURU-521165

(An Autonomous College in the jurisdiction of Krishna University, Machilipatnam)

Accredited with "A" Grade by NAAC, Bengaluru

MATHEMATICS	MAT-604CE	w.e.f.2020-21	III B.Sc
SEMESTER-VI	PAPER-VIII		Max.Marks:70
Hours/ Week: 5		No.of Credits: 5	

ELECTIVE – VIII-A-3: Project

Applications of advanced Numerical Analysis with 'C' Programme

EXAMINATION AT THE END OF SIXTH SEMESTER (w.e.f 2020-21)

MATHEMATICS Paper VIII MAT-602CE MAX.MARKS: 70 TIME: 3 hrs

Cluster Elective- VIII-A-1: INTEGRAL TRANSFORMS

Section – A (short answer questions)

Answer any **Four** of the following questions.

4x5 = 20M

Choosing at least **ONE** question from each Part.

PART – I

1. Solve $(D^2 - 2D + 2)y = 0$, $y = Dy = 1$, when $t = 0$.
2. Solve $(D^2 - 3D + 2)y = 1 - e^{2t}$, if $y = 1$, $Dy = 0$, when $t = 0$.
3. Solve $(D - 2)x + 3y = 0$, $2x + (D - 1)y = 0$ if $x(0) = 8$ and $y(0) = 3$.
4. Solve $\frac{\partial y}{\partial x} = 2\frac{\partial y}{\partial t} + y$, $y(x, 0) = 6e^{-3x}$ which is bounded for $x > 0$, $t > 0$.

PART – II

5. Convert $y''(t) - 3y'(t) + 2y(t) = 4 \sin t$, $y(0) = 1$, $y'(0) = -2$ into integral equation.
6. Solve the integral equation $F(t) = t + 2 \int_0^t \cos(t - u) F(u) du$.
7. Find the Fourier sine and cosine transform of $f(x) = x$
8. Show that $\int_0^\infty \frac{\cos \lambda x}{\lambda^2 + 1} d\lambda = \frac{\pi}{2} e^{-x}$, $x \geq 0$.

Section – B (long answer questions)

Answer any **FIVE** of the following questions.

5x10 = 50M

Choosing at least **TWO** question from each Part.

PART – I

9. Solve $(D + 1)^2 = t$, given that $y = -3$, when $t = 0$ and $y = -1$ when $t = 1$.
10. Solve $y'' - t y' + y = 1$ if $y(0) = 1$, $y'(0) = 2$.
11. Solve $(D^2 - 3)x - 4y = 0$, $x + (D^2 + 1)y = 0$, $t > 0$ if $x = y = Dy = 0$, $Dx = 2$.
12. Solve $\frac{\partial y}{\partial t} = \frac{\partial^2 y}{\partial x^2}$, $y(\frac{\pi}{2}, t) = 0$, $(\frac{\partial y}{\partial x})_{x=0} = 0$ and $y(x, 0) = \cos 3x$.

PART – II

13. Solve the integral equation $F(t) = 1 + \int_0^t F(u) \sin(t - u) du$ and verify your solution.

14. Solve the integral equation $\int_0^t \frac{F(u) du}{\sqrt{(t-u)}} = 1 + t + t^2$.

15. Find the Fourier transform of $f(x)$ defined by $f(x) = \begin{cases} 1, & |x| < a \\ 0, & |x| > a \end{cases}$ and hence evaluate

$$i \int_{-\infty}^{\infty} \frac{\sin pa \cos px}{p} dp \text{ ii) } \int_0^{\infty} \frac{\sin p}{p} dp.$$

16. Find the finite Fourier sine and cosine transforms of the function $f(x) = 2x, 0 < x < 4$.

**A.G & S.G SIDDHARTHA DEGREE COLLEGE OF ARTS AND SCIENCE,
VUYYURU – 521165, KRISHNA Dt., A.P.**

(An Autonomous College in the jurisdiction of Krishna University, Machilipatnam)
Accredited with “A” Grade by NAAC, Bengaluru

EXAMINATION AT THE END OF SIXTH SEMESTER (w.e.f 2020-21)

MATHEMATICS Paper VIII MAT-603CE MAX.MARKS: 70 TIME: 3 hrs

Cluster Elective VIII-A-2: ADVANCED NUMERICAL ANALYSIS

Section – A (short answer questions)

Answer any **Four** of the following questions.

4x5 = 20M

Choosing at least **ONE** question from each Part.

PART – I

1. Find the least square line $y = a + bx$ for the data

Xi: -2 -1 0 1 2

Yi: 1 2 3 3 4

2. Find $f^{-1}(5)$ from the following table

x: 1 2 4 8 10

f(x): 0 1 5 21 27

3. Evaluate $\int_0^1 \frac{1}{1+x^2} dx$ by Trapezoidal rule

4. Evaluate $\int_0^4 e^x dx$ by Simpson's $\frac{1}{3}$ rule

PART – II

5. Solve $3x + y + 2z = 3$, $2x - 3y - z = -3$, $x + 2y + z = 4$ by Matrix inversion method

6. Solve $x + y + z = 9$, $2x + 5y + 7z = 52$, $2x + y - z = 0$ by Cramer's rule

7. Given D.E is $\frac{dy}{dx} = 1 + xy$ with $y = 1$ when $x = 0$ compute $y(0.1)$

8. Solve the equation $y' = -y$ with $y(0) = 1$ for $x = 0.04$ in four steps

Section – B (long answer questions)

Answer any **FIVE** of the following questions.

5x10 = 50M

Choosing at least **TWO** question from each Part.

PART – I

9. Find the least square power function of the form $y = ax^b$ for the data
- X_i : 1 2 3 4
 Y_i : 3 12 21 35
10. Using the given table find $\frac{dy}{dx}$ and $\frac{d^2y}{dx^2}$ at $x = 1.2$
- x : 1.0 1.2 1.4 1.6 1.8 2.0 2.2
 y : 2.7183 3.3201 4.0552 4.9530 6.0496 7.3891 9.0250
11. Find the value of $\int_0^1 \frac{1}{1+x^2} dx$ by using Simpson's 3/8 rule and hence find the value of " π "
12. Evaluate $\int_4^{5.2} \log x dx$ by using Weddle's rule.

PART – II

13. Solve $2x + y + z = 10$, $3x + 2y + 3z = 18$, $x + 4y + 9z = 16$ by Gauss elimination method
14. Solve $3x + 2y + 4z = 7$, $2x + y + z = 7$, $x + 3y + 5z = 2$ by Factorization method
15. Solve the D.E $\frac{dy}{dx} = 1 + y^2$, $y(0) = 0$ by Picard's method
16. Given $\frac{dy}{dx} = y - x$ with $y(0) = 2$ find $y(0.1)$ and $y(0.2)$ correct to four decimal places by RK method.

**A.G & S.G SIDDHARTHA DEGREE COLLEGE OF ARTS AND SCIENCE,
VUYYURU – 521165, KRISHNA Dt., A.P.
(An Autonomous College in the jurisdiction of Krishna University, Machilipatnam)
EXAMINATION AT THE END OF SIXTH SEMESTER (w.e.f 2020-21)**

MATHEMATICS Paper VIII MAT-604CE MAX.MARKS: 70 TIME: 3 hrs

**Cluster Elective- VIII-A-3: PROJECT
Applications of advanced Numerical Analysis with ‘C’ Programme**

DEPARTMENT OF MATHEMATICS

Guidelines of III B.Sc for Question Paper Setters VI Semester-End Exams: 2020-21

Time: 3 Hrs **Elective.MAT- 601GE** Max.Marks:70

Paper Title : Numerical analysis

Note :- 1). Answer any FOUR questions out of 8 in Section-A.
Each question carries 5 marks. (4x5=20 Marks)

2). Answer any FIVE questions out of 8 in Section-B.
Each question carries 10 marks. (5x10 =50 marks)

Questions to be set as follows:

	Unit-1	Unit-2	Unit-3	Unit-4	Unit-5
<u>Section-A</u> (Short Answer Questions)	1	2	2	2	1
<u>Section-B</u> (Essay Questions)	1	2	2	2	1

-The End -

DEPARTMENT OF MATHEMATICS

Guidelines of III B.Sc for Question Paper Setters VI Semester-End Exams: 2020-21

Time: 3 Hrs **Cluster.MAT- 602CE**

Max.Marks:70

Paper Title: Integral Transforms

Note :- 1). Answer any FOUR questions out of 8 in Section-A.

Each question carries 5 marks.

(4x5=20 Marks)

2). Answer any FIVE questions out of 8 in Section-B.

Each question carries 10 marks.

(5x10 =50 marks)

Questions to be set as follows:

	Unit-1	Unit-2	Unit-3	Unit-4	Unit-5
<u>Section-A</u> (Short Answer Questions)	2	2	2	1	1
<u>Section-B</u> (Essay Questions)	2	2	2	1	1

-The End -

DEPARTMENT OF MATHEMATICS

Guidelines of III B.Sc for Question Paper Setters VI Semester-End Exams: 2020-21

Time: 3 Hrs **Cluster.MAT- 603CE**

Max.Marks:70

Paper Title: Advanced Numerical Analysis

Note :- 1). Answer any FOUR questions out of 8 in Section-A.

Each question carries 5 marks.

(4x5=20 Marks)

2). Answer any FIVE questions out of 8 in Section-B.

Each question carries 10 marks.

(5x10 =50 marks)

Questions to be set as follows:

	Unit-1	Unit-2	Unit-3	Unit-4	Unit-5
<u>Section-A</u> (Short Answer Questions)	1	1	2	2	2
<u>Section-B</u> (Essay Questions)	1	1	2	2	2

-The End -

**A.G& S.G.SIDDHARTHA DEGREE COLLEGE OF ARTS &
SCIENCE**

VUYYURU-521165, KRISHNA Dt., A.P.(Autonomous)

Accredited by NAAC with "A" Grade

2021-2022



**DEPARTMENT OF PHYSICS
MINUTES OF BOARD OF STUDIES**







ODD SEMESTER

02-11-2021

Minutes of the meeting of Board of studies in Physics for the Autonomous course of A.G. & S.G. Siddhartha Degree College of Arts & Science, Vuyyuru held at 10.30 A.M on 02 – 11 - 2021 in the Department of Physics.

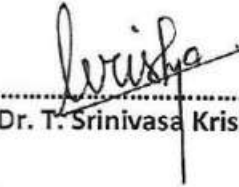
Sri U. Ram Prasad Presiding

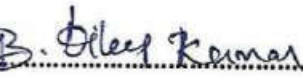
Members Present:

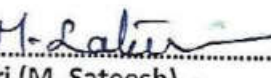
- 1)  Chairman
(Sri U. Ram Prasad)
Head, Department of Physics
A.G. & S.G.S. Degree College of Arts & science,
Vuyyuru - 521165
- 2)  University Nominee
(Dr. M. Rami Reddy)
Registrar
Krishna University,
Machilipatnam.
- 3)  Academic Council Nominee
(Dr. T. Srinivasa Krishna)
Associate Professor,
H.O.D Dept. of Physics,
P.B. Siddhartha college of arts & science,
Vijayawada.
- 4)  Academic Council Nominee
(Sri P.V. Ramana)
H.O.D Dept. of Physics,
A.J. Kalasala,
Machilipatnam.
- 5)  Representative from Industry
(Sri I. Chittibabu)
Sub Divisional Engineer,
BSNL,
Vijayawada.
- 6)  Alumini
(Sri B. Dileep Kumar)
Lecturer in Physics,
Dept. of Physics, IIIT ,
Nuzivid.
- 7)  Member
(Sri J. Hareeshchandra)
Lecturer in Physics,
A.G. & S.G.S. Degree College of Arts & Science,
Vuyyuru - 521165.
- 8)  Member
(Sri M. Sateesh)
Lecturer in Physics,
A.G. & S.G.S. Degree College of Arts & Science,
Vuyyuru - 521165.

9) M.P.D. Parimala
(Smt. M.P.D. Parimala)

Member

Lecturer in Physics,

A.G. & S.G.S.Degree College
of Arts & Science,
Vuyyuru - 521165.

10) J. Dileep
(Sri J. Dileep)

Member

Lecturer in Physics,

A.G. & S.G.S.Degree College
of Arts & Science,
Vuyyuru - 521165.

Agenda for B.O.S Meeting

1. To recommend the syllabi and model papers for I semester of I Degree B.Sc., Physics for the Academic year 2021-2022.
2. To recommend the syllabi and model papers for III semester of II Degree B.Sc., Physics for the Academic year 2021-2022.
3. To recommend the syllabi and model papers for V semester of III Degree B.Sc. Physics for the Academic year 2021-2022.
4. To recommend the Blue print of question papers for I, III & V semesters of B.Sc. Physics for the Academic year 2021-2022.
5. To recommend the Guidelines to be followed by the question paper setters in Physics for I, III, V Semester – end exams.
6. To recommend the teaching and evaluation methods to be followed under Autonomous Status.
7. Any suggestions regarding seminars, workshops, Guest lecture to be organized.
8. Recommend the panel of paper setters and Examiners to the controller of Examinations of Autonomous Courses of A.G. & S.G.S. Degree colleges of Arts & Science, Vuyyuru.
9. Any other matter.

Chairman.

RESOLUTIONS

- 1) It is resolved to Change the **syllabi and model papers for I semester of I B.Sc.** under Choice Based Credit System (CBCS 2020-2021 onwards) for the Academic year 2021-22.
- 2) It is resolved to change the **syllabi and model papers for III semester of II B.Sc. under Choice Based Credit System (CBCS 2020-2021 onwards) for the Academic year 2021-22** .
- 3) It is resolved to follow the same **syllabi and model papers** under Choice Based Credit System (CBCS) prescribed by Krishna University for **V semester of III B.Sc.**
- 4) It is resolved to change the **Blue print** of I and III semesters of Degree I & II B.Sc. for the Academic year 2021-22.
 - It is resolved to continue the same **Blue prints** of V semester of Degree B.Sc. for the Academic year 2021-22 also.
- 5) It is resolved to change the **Guidelines** of I and III semesters of Degree I & II B.Sc. for the Academic year 2021-22.
 - It is resolved to continue the same **Guidelines** of V semesters of Degree B.Sc. for the Academic year 2021-22.
- 6) It is resolved to continue the following teaching and evolution methods for Academic year 2021-2022.

Teaching Methods:

Besides the conventional methods of teaching, we use modern technology i.e. using of LCD projector, U boards, virtual lab etc, for better understanding of concepts.

Evaluation of a student is done by the following procedure:

➤ Internal Assessment Examinations:

- For I B.SC.(sem I) out of 100 marks in each paper, 25 marks shall be allocated for internal assessment and 75 marks shall be allotted for external valuation.
- Out of these 25 marks, **15 marks are allocated for announced tests (i.e.IA-1 & IA-2).** Two announced tests will be conducted and average of these two tests shall be deemed as the marks obtained by the student, **5 marks** are allocated on the basis of candidate's **percentage of attendance and remaining 5 marks are allocated for the assignment.**
- For II B.SC.(sem III) out of 100 marks in each paper, 30 marks shall be allocated for internal assessment and 70 marks shall be allotted for external valuation.
- For III B.Sc (**i.e. V semester**) out of 100 marks in each paper, 30 marks shall be allocated for internal assessment and 70 marks shall be allotted for external valuation.
- Out of these 30 marks, **20 marks are allocated for announced tests (i.e.IA-1 & IA-2).** Two announced tests will be conducted and average of these two tests shall be deemed as the marks obtained by the student, **5 marks** are allocated on the basis of candidate's **percentage of attendance, and 5 marks** are allocated for **assignment / class room seminars.**

➤ **Semester – End Examination:**

- The maximum marks for I B.Sc. Semester I – End examination shall be 75 marks and duration of the examination shall be 3 hours.
 - The maximum marks for II B.Sc. and III B.Sc. Semesters III and V – End examination shall be 70 marks and duration of the examination shall be 3 hours.
 - **Semester – End examinations** in theory papers and **practical Examinations** shall be conducted at the end of every semester **I, III & V** for **I, II & III B.Sc.**
- 7) Discussed and recommended for organizing seminars, **Guest lecturers, workshops** to upgrade the knowledge of students, for the approval of the academic council.
 - 8) Discussed and empowered the Head of the department of Physics to suggest the panel of paper setters and examiners to the controller of examinations.
 - 9) Proposed to conduct add on Programme /Certificate course.

Chairman.

A.G & S.G Siddhartha Degree College of Arts and Science, Vuyyuru
(An Autonomous college in the jurisdiction of Krishna University)
Accredited at the 'A' level by NAAC
SEMESTER- I
PAPER- I Total hrs-60
MECHANICS, WAVES AND OSCILLATIONS **Credits-3**

Course outcomes:

On successful completion of this course, the students will be able to:

- CO1:** Understand Newton's laws of motion and motion of variable mass system and its application to rocket motion and the concepts of impact parameter, scattering cross section.
- CO2:** Apply the rotational kinematic relations, the principle and working of gyroscope and its applications and the precessional motion of a freely rotating symmetric top. Comprehend the general characteristics of central forces and the application of Kepler's laws to describe the motion of planets and satellite in circular orbit through the study of law of Gravitation.
- CO3:** Understand postulates of Special theory of relativity and its consequences such as length contraction, time dilation, relativistic mass and mass-energy equivalence. Examine phenomena of simple harmonic motion and the distinction between undamped, damped and forced oscillations and the concepts of resonance and quality factor with reference to damped harmonic oscillator.
- CO4:** Appreciate the formulation of the problem of coupled oscillations and solve them to obtain normal modes of oscillation and their frequencies in simple mechanical systems.
- CO5:** Figure out the formation of harmonics and overtones in a stretched string and acquire knowledge on Ultrasonic waves, their production and detection and their applications in different fields.

A.G & S.G Siddhartha Degree College of Arts and Science, Vuyyuru
(An Autonomous College in the jurisdiction of Krishna University, Machilipatnam A.P. India)

PHYSICS	PHY-101C	2020-2021	B.Sc. (MPC&MPCs)
----------------	-----------------	------------------	-----------------------------

Semester-I

Work load: 60 hrs per semester

4 hrs/week

Credits – 4

Paper-III MECHANICS, WAVES AND OSCILLATIONS

UNIT-I:

1. Mechanics of Particles (5 hrs)

Review of Newton's Laws of Motion, Motion of variable mass system, Multistage rocket, Concept of impact parameter, scattering cross-section, Rutherford scattering-Derivation.

2. Mechanics of Rigid bodies (7 hrs)

Rigid body, rotational kinematic relations, Equation of motion for a rotating body, Angular momentum and Moment of inertia tensor, Euler equations, Precession of a spinning top, Gyroscope, Precession of the equinoxes

Unit-II:

3. Motion in a Central Force Field (12hrs)

Central force - definition and examples, characteristics of central forces, conservative nature of central forces, Equation of motion under a central force, Kepler's laws of planetary motion-Proofs, Motion of satellites – **escape velocity, orbital velocity**, Basic idea of Global Positioning System (GPS),

UNIT-III:

4. Relativistic Mechanics (12 hrs)

Introduction to relativity, Frames of reference - Galilean transformations, absolute frames, Michelson-Morley experiment & negative result, Postulates of Special theory of relativity, Lorentz transformation, time dilation, length contraction, variation of mass with velocity, Einstein's mass-energy relation

Unit-IV:

5. Undamped, Damped and Forced oscillations: (07 hrs)

Simple harmonic oscillator, Damped harmonic oscillator, Forced harmonic oscillator –differential equations and solutions, Resonance, Logarithmic decrement, Relaxation time and Quality factor.

6. Fourier analysis (05 hrs)

Fourier theorem (Statement & limitations), evaluation of the Fourier coefficients using Fourier's theorem, analysis of periodic wave functions - square wave, triangular wave.

Unit-V:

7. Vibrating Strings: (07 hrs)

Transverse wave propagation along a stretched string, General solution of wave equation and its significance, Modes of vibration of stretched string clamped at ends, Overtones and Harmonics.-

8. Ultrasonics: (05 hrs)

Ultrasonics, General Properties of ultrasonic waves, Production of ultrasonics by piezoelectric and magnetostriction methods, Detection of ultrasonics, Applications of ultrasonic waves, SONAR

STUDENT ACTIVITY

1. Seminars
2. Assignments.

LIBRARY ACTIVITY

Student visit library to refer and gather information regarding seminar topics and assignments.

TEXT BOOKS

1. B. Sc. Physics, Vol.1, Telugu Academy, Hyderabad
2. Unified Physics - Waves and Oscillations, Jai PrakashNath & Co.Ltd.

REFERENCE BOOKS:

1. Fundamentals of Physics Vol. I - Resnick, Halliday, Krane, Wiley
2. College Physics-I. T. Bhimasankaram and G. Prasad. Himalaya Publishing House.
3. University Physics-FW Sears, MW Zemansky & HD Young, Narosa Publications, Delhi
4. Mechanics, S.G. Venkatachalapathy, Margham Publication, 2003.
5. Waves and Oscillations. N. Subramanyam and Brijlal, VikasPulications.
6. Waves & Oscillations. S. Badami, V. Balasubramanian and K.R. Reddy, Orient Longman.

7. The Physics of Waves and Oscillations, N.K. Bajaj, Tata McGraw Hill
8. Science and Technology of Ultrasonics- Baldevraj, Narosa, New Delhi,2004

Model Question Paper

Mechanics, Waves and Oscillations

SECTION-A

Answer the following:

5 x 10 = 50 M

- 1 A) What is Rutherford scattering? Obtain an expression for number of particles scattered per unit area. (CO1).

(OR)

B) What is precessional motion? Find angular velocity of precession of a spinning top. Show that the rate of precession is independent of mass but depends on the distribution of mass. (CO2).

2. A) What is conservative force? Show that central forces are conservative. (CO2).

(OR)

B) State Kepler's third law of motion. And prove that the square of period of revolution of a planet moving in a circular orbit round the sun is proportional to the cube of its distance from the sun. (CO2)

- 3 A) State the fundamental postulates of special theory of relativity and deduce the Lorentz transformations. (CO3)

(OR)

B) Describe the Michelson-Morley experiment and explain the physical significance of negative results. (CO3)

- 4 A) What are damped oscillations? Derive the differential equation of damped Harmonic oscillator and discuss the case of under damping. (CO3).

(OR)

B) State Fourier Theorem and evaluate Fourier coefficients. (CO4).

- 5 A) What are transverse waves? Obtain the equation of velocity of transverse wave in a wire kept under tension. (CO5).

(OR)

B) What are ultrasonics? Describe Magnetostriction method of producing ultrasonics (CO5).

SECTION-B

Answer any **THREE** of the following questions:

3x5=15M

6. State Newton's laws of motion and give two examples each. (CO1)
7. Explain central forces with examples. (CO2)
8. Explain time dilation. (CO3)
9. What is logarithmic decrement and relaxation time? (CO4)
10. Explain overtones and harmonics. (CO5)

Section – C

2X5=10M

Answer any **TWO** of the following:

11. The kinetic energy of metal disc rotating at a constant speed of 5 revolutions per second is joules. Find the angular momentum of the disc. (CO2)
12. If the Earth be one-half of its present distance from the sun, what will be the number of days in a year (CO2)
13. If the energy note of frequency 100Hz decreases to one half of its original value in one second, calculate the Q-factor, (CO4)
13. A piezoelectric crystal has a thickness of 0.002m. If the velocity of sound wave in crystal is 5750m/s, calculate the fundamental frequency of crystal. (CO5)

Practical Course 1: Mechanics, Waves and Oscillations

Work load: 30 hrs

2 hrs/week

Credits:01

Course outcomes (Practicals):

On successful completion of this practical course, the student will be able to:

- CO 1.** Perform experiments on Properties of matter such as the determination of moduli of elasticity viz., Young's modulus, Rigidity modulus of certain materials; Surface tension of water, Coefficient of viscosity of a liquid, Moment of inertia of some regular bodies by different methods and compare the experimental values with the standard values.

- CO 2.** Know how to determine the acceleration due to gravity at a place using Compound pendulum and Simple pendulum.

- CO 3.** Notice the difference between flat resonance and sharp resonance in case of volume resonator and sonometer experiments respectively.

- CO 4.** Verify the laws of transverse vibrations in a stretched string using sonometer and comment on the relation between frequency, length and tension of a stretched string under vibration.

- CO 5.** Demonstrate the formation of stationary waves on a string in Melde's string experiment.

- CO 6.** Observe the motion of coupled oscillators and normal modes.

EXPERIMENTS LIST:

1. Young's modulus of the material of a bar (scale) by uniform bending
2. Young's modulus of the material a bar (scale) by non- uniform bending
3. Surface tension of a liquid by capillary rise method

4. Simple pendulum- normal distribution of errors-estimation of time period and the error of the mean by statistical analysis
5. Determination of 'g' by compound/bar pendulum
6. Verification of laws of vibrations of stretched string –Sonometer
7. Bifilar suspension –Moment of inertia of a regular rectangular body.
8. Rigidity modulus of material of a wire-Dynamic method (Torsional pendulum)
9. Volume resonator experiment
10. Viscosity of liquid by the flow method (Poiseuille's method)
11. Determination of the force constant of a spring by static and dynamic method. Coupled oscillators
12. Determination of frequency of a bar –Melde's experiment.

Note :

1. 9 (NINE) experiments are to be done and recorded in the lab. These experiments will be evaluated in CIA.
2. For certification minimum of 7 (Seven) experiments must be done and recorded by student who had put in 75 % of attendance in the lab.
3. **Best 6 experiments are to be considered for CIA.**
4. 10 marks for CIA.
5. 40 marks for practical exam.

The marks distribution for the Semester End practical examination is as follows:

Formula/ Principle / Statement with explanation of symbols	05
Diagram/Circuit Diagram / Tabular Columns	05
Setting up of the experiment and taking readings/Observations	10
Calculations (explicitly shown) + Graph + Result with Units	05
Procedure and precautions	05
Viva-voce	05
Record	05
Total Marks:	40

A.G & S.G Siddhartha Degree College of Arts and Science, Vuyyuru

(An Autonomous College in the jurisdiction of Krishna University, Machilipatnam A.P. India)

Semester-III

Work load: 60 hrs

4 hrs/week

Credits: 03

Paper-III *THERMODYNAMICS AND RADIATION PHYSICS*

COURSE OUTCOMES

Upon successful completion of this course, students should have the knowledge and skills to:

- CO1 Understand the microscopic behavior of molecules, interactions and the concepts of transport phenomena of heat transfer, mass transfer and momentum transfer.
- CO2 State the First Law and define heat, work, thermal efficiency and the difference between various forms of energy and describe energy exchange processes, reversible and irreversible process.
- CO3 Derive thermodynamic potentials from first principles and derive the Maxwell relations.
- CO4 Understand very low temperatures like the concept of Joule Thomson effect, Liquefaction of gases and the properties at very low temperatures.
- CO5 Understanding of Black-body radiation as the thermal electromagnetic radiation and the statistical principles to the mechanical behavior of large number of small particles.

A.G & S.G Siddhartha Degree College of Arts and Science, Vuyyuru

(An Autonomous College in the jurisdiction of Krishna University, Machilipatnam A.P. India)

PHYSICS	PHY-301C	2020-2021	B.Sc. (MPC&MPCs)
----------------	-----------------	------------------	-----------------------------

Semester-III

Work load: 60 hrs per semester

4 hrs/week

Credits – 4

Paper-III *THERMODYNAMICS AND RADIATION PHYSICS*

UNIT-I:

Kinetic Theory of gases: (12 hrs)

Kinetic Theory of gases-Introduction, Maxwell's law of distribution of molecular velocities (qualitative treatment only), Mean free path, Degrees of freedom, Principle of equipartition of energy (Qualitative ideas only), Transport phenomenon in ideal gases: viscosity, Thermal conductivity and diffusion of gases.

UNIT-II:

Thermodynamics: (12hrs)

Introduction- Isothermal and Adiabatic processes, Reversible and irreversible processes, Carnot's engine and its efficiency, Carnot's theorem, Thermodynamic scale of temperature and its identity with perfect gas scale, Second law of thermodynamics - Kelvin's and Clausius statements; ~~Principle of refrigeration~~; Entropy, Physical significance, Change in entropy in reversible and irreversible processes; Entropy and disorder-Entropy of Universe; Temperature-Entropy (T-S) diagram and its uses - change of entropy when ice changes into steam (**Qualitative**).

UNIT-III:

Thermodynamic Potentials and Maxwell's equations: (12hrs) (**NO PROBLEM**)

Thermodynamic potentials-Internal Energy, Enthalpy, Helmholtz Free Energy, Gibb's Free Energy and their significance, Derivation of Maxwell's thermodynamic relations from thermodynamic potentials, Applications to (i) Clausius-Clayperon's equation (ii) Value of $C_p - C_v$ (iii) Value of C_p/C_v (iv) Joule-Kelvin coefficient for ideal and Van der Waals' gases

UNIT-IV:

Low temperature Physics: (12hrs)

Methods for producing very low temperatures, Joule Kelvin effect, Porous plug experiment, Joule expansion, Distinction between adiabatic and Joule Thomson expansion, Expression for Joule Thomson cooling, Production of low temperatures by adiabatic demagnetization **(Derivation)**, **Principle of Refrigeration, effects of chloro and fluoro carbons on ozone layer.**

UNIT-V:

Quantum theory of radiation: (12 hrs)

Blackbody and its spectral energy distribution of black body radiation, Kirchoff's law, Wein's displacement law, Stefan-Boltzmann's law and Rayleigh-Jean's law (No derivations), Planck's law of black body radiation-Derivation, Deduction of Wein's law and Rayleigh- Jean's law from Planck's law, Solar constant and its determination using Angstrom pyroheliometer, Estimation of surface temperature of Sun.

TEXT BOOKS

1. BSc Physics, Vol.2, Telugu Academy, Hyderabad
2. Unified Physics Vol.2, Optics & Thermodynamics, Jai Prakash Nath &Co.Ltd., Meerut

REFERENCE BOOKS:

1. Thermodynamics, R.C. Srivastava, S.K. Saha & Abhay K. Jain, Eastern Economy Edition.
2. Fundamentals of Physics. Halliday/Resnick/Walker.C. Wiley India Edition 2007
3. Heat, Thermodynamics and Statistical Physics-N Brij Lal, P Subrahmanyam, P S Hemne, S. Chand& Co., 2012
4. Heat and Thermodynamics- MS Yadav, Anmol Publications Pvt. Ltd, 2000
5. University Physics, HD Young, MW Zemanski Sears, Narosa Publishers, New Delhi

The Guidelines to be followed by the question paper setters in Physics for the III Semester - end exams

PAPER TITLE: Thermodynamics and Radiation Physics

Paper- III Semester – III Maximum marks: 70 marks

Duration: 3Hours

Weightage for the question paper

Syllabus	Section-A (Short answer questions)	Section-B (essay questions)
Unit-1(20 Marks)	T+P	1
Unit-2(30 Marks)	T+P	2
Unit-3(15Marks)	T	1
Unit-4(25 Marks)	T	2
Unit-5(30 Marks)	T+P	2

Note: T means one theory question, P means one problem

- **Section-A** contains **5** short questions and **3** problems out of these **8** questions, the student has to answer any **4**, each question carries **5** marks.
- **Section –B** contains **8** essay questions, the student has to answer any **5** questions, each question carries **10** marks.
- The Question papers setters are requested to cover all the topics in the syllabus as per the weightage given by us.

Model Question Paper

Title of the Paper: Thermodynamics and Radiation Physics

Section-A

Answer any **FOUR** of the following:

4X5=20M

1. Write a note mean free path. (CO1)
2. Explain the second law of thermodynamics in terms of entropy. (CO2)
3. Prove $C_p - C_v = R$ (CO3)
4. Explain the effects of chloro and fluoro carbons on ozone layer. (CO4)
5. Estimate the temperature of sun. (CO5)
6. Find the R.M.S velocity of hydrogen at N.T.P and at C° (CO1)
7. Calculate the efficiency of a reversible engine that operates between the temperatures 200°C and 120°C ? (CO1)
8. Find the wavelength at which maximum energy is radiated by a black at a temperature of 227°C and wien's constant is $2.877 \times 10^{-3} \text{mk}$. (CO1)

Section-B

Answer any **FIVE** of the following:

5X10=50M

9. Derive an expression for Maxwell's law of distribution of molecular speeds in a gas. (CO1)
10. Describe the working of Carnot's reversible engine and derive an expression for its efficiency. (CO2)
11. What are reversible and irreversible processes? How does the entropy change in each of these processes? (CO2)
12. Define the four thermodynamic potentials. Obtain Maxwell's thermodynamic equations using these potentials. (CO3)
13. What is adiabatic demagnetization? How is this principle used in producing low temperatures? (CO4)
14. Explain Joule-kelvin effect. Derive an expression for Joule-Thompson cooling. (CO4,)

15. Derive the Planck's formula for the distribution of energy in black body radiation. (CO5)
16. Describe the construction and working of Angstrom pyroheliometer (CO5)

A.G & S.G Siddhartha Degree College of Arts and Science, Vuyyuru
(An Autonomous College in the jurisdiction of Krishna University, Machilipatnam)

PHYSICS	PHYP301C	2020-21	B.Sc. (MPC&MPCs)
----------------	-----------------	----------------	-----------------------------

Practical Paper III: Thermodynamics and Radiation Physics Lab

Work load: 30hrs

2 hrs/week

Credits: 01

Objectives:

The primary objective of this course is to provide the fundamental knowledge to understand the behaviour of thermal systems.

This course provides a detailed necessary transfer through solids, fluids, and experimental analysis, including the application and heat vacuum.

Convection, conduction, and radiation heat transfer in one and two dimensional steady and unsteady systems are examined.

COURSE OUTCOMES

Upon successful completion of this course, students should have the knowledge and skills to:

- CO1: Determine the thermal conductivity of bad conductor-Lee's method, thermal conductivity of rubber and Coefficient of thermal conductivity of copper by using Searle's apparatus.
- CO2: Study the heating efficiency of electrical kettle with varying voltages.
- CO3: Determine Specific heat of a liquid by Joule's calorimeter and study Barton's radiation correction by plotting a graph between temperature and time and Specific heat of a liquid by applying Newton's law of cooling correction.
- CO4: Study temperature variation of resistance in a thermostat.
- CO5: Study the heating efficiency of electrical kettle with varying voltages.

List of experiments

1. Study of variation of resistance with temperature - Thermistor.
2. Thermal conductivity of bad conductor-Lee's method
3. Thermal conductivity of rubber.
4. Measurement of Stefan's constant - emissive method
5. Heating efficiency of electrical kettle with varying voltages.
6. Specific heat of a liquid –Joule's calorimeter –Barton's radiation correction
7. Specific heat of a liquid by applying Newton's law of cooling correction.
8. Thermo emf- thermo couple - Potentiometer
9. Thermal behavior of an electric bulb (filament/torch light bulb)
10. Measurement of Stefan's constant

Note :

1. 9 (NINE) experiments are to be done and recorded in the lab. These experiments will be evaluated in CIA.
2. For certification minimum of 7 (Seven) experiments must be done and recorded by student who had put in 75 % of attendance in the lab.
3. **Best 6 experiments are to be considered for CIA.**
4. 10 marks for CIA.
5. 40 marks for practical exam.

The marks distribution for the Semester End practical examination is as follows:

Formula/ Principle / Statement with explanation of symbols	05
Diagram/Circuit Diagram / Tabular Columns	05
Setting up of the experiment and taking readings/Observations	10
Calculations (explicitly shown) + Graph + Result with Units	05
Procedure and precautions	05
Viva-voce	05
Record	05
Total Marks:	40

**A.G. & S.G.SIDDHARTHA DEGREE COLLEGE OF ARTS &
SCIENCE**

(AUTONOMOUS), VUYYURU – 521 165

III B.Sc. 5th Semester (2020-2021)

Paper V: Electricity, Magnetism and Electronics

Work load:60 hrs per semester 4 hrs/week Course Code : PHY 501C

Unit – I(12hrs)

1.Electrostatics

Gauss's law Statement and its proof-Electric field intensity due to (1) Uniformly charged sphere and (2) an infinite conducting sheet of charge. Electric potential- Equipotential surface –potential due to i) a point charge ii) charged spherical shell .

2.Dielectrics

Electric dipole moment and molecular polarizability- Electric displacement D, electric polarization P – relation between D, E, and P- Dielectric constant, susceptibility .

Unit – II(12hrs)

3. Electric and magnetic field Biot – Savart's law and calculation of B due to long straight wire, a circular current loop and solenoid. Hall effect-determination of Hall coefficient and applications.

4.Electromagnetic-induction

Faraday's law – Lenz's law self and mutual inductance, coefficient of coupling, calculation of self inductance of a long solenoid, energy stored in magnetic field. Transformer- energy losses and efficiency.

Unit-III(12hrs)

5.Alternating current and electro magnetic waves

Alternating current –Relation between current and voltage in LR and CR circuits, vector diagrams, LCR series and parallel resonant circuit , Q- factor, power in AC circuits.

6.Maxwell's equations

Idea of displacement current- Maxwell's equations (integral and differential forms) (no derivation) Maxwell's wave equation(with derivation), Transverse nature of electromagnetic wave. Poining Vector (statement and proof) production of electromagnetic wave Hertz experiment.

Unit-IV(12hrs)

7.Basic electronics:

PN junction diode Zener diode ,I-V characteristics, PNP and NPN Transistors, CB,CE and CC configuration Relation between α β and Γ transistors (CE) characteristics, Transistor as an amplifier.

Unit-V(12hrs)

Digital electronics:

Number systems-conversion of binary to decimal system and vice versa. Binary addition and subtraction (1's and 2's complement methods) laws of Boolean algebra-De Morgan's laws-statement and proof basic logic gates, NAND and NOR as universal gates Half adder and FULL adder.

REFERENCE BOOKS

- 1) BSC Physics vol.3 Telugu Akademy, Hyderabad.
- 2) Electricity, Magnetism D,N Vasudeva. S.chand & co.,
- 3) Electricity, Magnetism and Electronics, K.K.Tewai, R.Chand &co.,
- 4) Principles of electronics, V.K.Mehta, S.Chand &co.,
- 5) Digital principles and applications A.P Malvino and D.P.Leach, Mc GrawHILL Edition.

The Guidelines to be followed by the question paper setters in Physics for the V Semester - end exams

PAPER TITLE: Electricity, Magnetism and Electronics

Paper- V Semester – V Maximum marks: 70 marks Duration: 3Hours
Weightage for the question paper

Syllabus	Section-A (Short answer questions)	Section-B (essay questions)
Unit-1 (25 Marks)	T	2
Unit-2 (20 Marks)	T+P	1
Unit-3 (30Marks)	T+P	2
Unit-4 (20 Marks)	T+T	1
Unit-5 (25 Marks)	T	2

Note: **T** means one theory question, **P** means one problem

- **Section-A** contains **6** short questions and **2** problems out of these **8** questions, the student has to answer any **4**, each question carries **5** marks.
- **Section –B** contains **8** essay questions, the student has to answer any **5** questions, each question carries **10** marks.
- The Question papers setters are requested to cover all the topics in the syllabus as per the weightage given by us.

SEMESTER – V	COURSE CODE : PHY- 501 C
PAPER TITLE : Electricity, Magnetism and Electronics	

Duration : 3Hours Maximum marks : 70 Pass marks : 28 marks

MODEL PAPER

III B.Sc. (PHYSICS)- V SEMESTER
ELECTRICITY, MAGNETISM AND ELECTRONICS

TIME: 3 Hrs PHY – 501 C MAX MARKS: 70 PASS MARK : 28

.....
SECTION – A

ANSWER ANY FOUR OF THE FOLLOWING (4 X 5 = 20 M)

- 1) Write a short note on equi - potential surfaces
- 2) obtain an expression for energy stored in a magnetic field
- 3) Derive expression for power in ac circuit
- 4) Explain CE configuration of a transistor
- 5) Explain briefly how a transistor works as an amplifier
- 6) Explain about half adder circuit with truth table.
- 7) Calculate the intensity of the magnetic field at the center of a circular coil of radius 20 cm and 40 turns having a current of 2A in it.
- 8) In a series RLC circuit $R = 100 \text{ ohm}$, $L = 0.5\text{H}$ and $C = 0.4 \mu\text{F}$. calculate resonant frequency

SECTION – B

ANSWER ANY FIVE OF THE FOLLOWING QUESTIONS (5 X 10 = 50 M)

- 9) Derive an expression for the electric field due to uniformly charged sphere using Gauss law?
- 10) Define D, E and P derive the relation between them
- 11) Calculate the magnetic induction due to a long straight wire using Biot- savart's law
- 12) State and prove pointing theorem
- 13) Explain the growth and decay of charge in LR- circuit
- 14) Describe the construction and working of Zener diode.
- 15) State and prove De Morgan's theorem with examples.
- 16) Explain about basic logic gates with truth tables.

Practical paper V: Electricity, Magnetism and Electronics

Exam duration : 3Hours

Maximum marks : 50 marks

Work load:30hrs

Minimum of 6 experiments to be done and recorded

1. Figure of merit of a moving coil galvanometer.
2. LCR circuit series/parallel resonance, Q-factor
3. Determination of Ac-frequency-sonometer
4. Verification of Kirchoff's laws
5. Field along the axis of a circular coil carrying current.
6. PN Junction diode Characteristics
7. characteristics of Zener diode
8. Transistor CE Characteristics.
9. Logic Gates –OR ,AND, NOT,and NAND gates verification of truth tables.
10. Verification of De Morgan's theorems.

DEPARTMENT OF PHYSICS
A.G. & S.G.SIDDHARTHA DEGREE COLLEGE OF ARTS &
SCIENCE

(AUTONOMOUS), VUYYURU – 521 165

III B.Sc. Physics – V Semester – Paper –VI (2020 – 2021)

Modern Physics

Course Code : PHY 502C Work Load : 60 hrs per semester 4 hrs/week

Unit – I (12 hrs) 1. Atomic and molecular physics

Introduction – Drawbacks of Bohr's atomic model – Sommerfeld's elliptical orbits-relativistic correction (no derivation). Vector atom model and Stern & Gerlach experiment - quantum numbers associated with it. L-S and j-j coupling schemes. Zeeman Effect and its experimental study.

Raman effect, Stokes and Anti Stokes lines . Quantum theory of Raman effect. Experimental arrangement – Applications of Raman effect.

UNIT – II (12 hrs) 2. Matter waves & Uncertainty Principle

Matter waves, de Broglie's hypothesis – wavelength of matter waves, Properties of matter waves – Davisson and Germer experiment, uses of electron diffraction-Phase velocity and Group velocity (definitions only)- relation between phase velocity and Group velocity–Heisenberg's uncertainty principle for position and momentum (x and p) & energy and time (E and t). Experiment verification.

UNIT – III (12 hrs) 3. Quantum (wave) mechanics

Basic postulates of quantum mechanics – Schrodinger time independent and time dependent wave equation – derivations. Physical interpretation of wave function. Applications of Schrodinger wave equation to particle in one dimensional infinite box. Harmonic oscillator.

UNIT – IV (12 hrs) 4. General properties of Nuclei

Basic ideas of nucleus – size, mass, charge density (matter energy), binding energy, angular momentum, parity, magnetic moment, electric quadrupole moments. Liquid drop model and shell model (qualitative aspects only)- Magic numbers.

5. Radioactivity decay

Alpha decay : basis of α – decay processes. Range of α -particles , Geiger's Law, Geiger- Nuttal law. β – decay, β ray continuous and discrete spectrum, neutrino hypothesis.

UNIT – V (12 hrs)

6. Crystal structure

Amorphous and crystalline materials, unit cell, Miller indices, reciprocal lattice, types of lattices, diffraction of X- rays by crystals, Bragg's law, experimental techniques, Laue's method and powder diffraction method.

7. Superconductivity:

Introduction – experimental facts, critical temperature – critical field – Meissner effect – isotope effect – Type I and Type II superconductors – BCS theory (elementary ideas only) – applications of superconductors.

REFERENCE BOOKS :

1. B.Sc physics, VOL .4, Telugu academy , Hyderabad.
2. Molecular structure and spectroscopy by G.Aruldas. prentice Hall of india , New Delhi.
3. Modern physics by R.Murugeshan and Kiruthiga siva prasanth. S. Chand & co.
4. Modern physics by G.Aruldas & p. Rajagopal. Eastren economy edition.
5. Concepts of Modern physics by Arthur Beiser. Tata McGrew – Hill Edition.
6. Quantum Mechanics, Mahesh c Jain , Eastern Economy EDITION
7. Nuclear Physics ,Irving Kaplan, Narosa Publishing House.
8. Nuclear physics , D.C Tayal, Himalaya publishing house.
9. Elements of solid state physics, J.P srivastava, Prentice Hall of india pvt. Ltd.
10. Solid state physics, A.J.Dekkar, McMillan India.

The Guidelines to be followed by the question paper setters in Physics for the V Semester - end exams

PAPER TITLE: Modern Physics

Paper- VI Semester – V Maximum marks: 70 marks Duration: 3Hours
Weightage for the question paper

Syllabus	Section-A (Short answer questions)	Section-B (Essay questions)
Unit-1 (25 Marks)	T	2
Unit-2 (20 Marks)	T+P	1
Unit-3 (25Marks)	T	2
Unit-4 (20 Marks)	T+T	1
Unit-5 (30 Marks)	T+P	2

Note: T means one theory question, P means one problem

- **Section-A** contains 6 short questions and 2 problems out of these 8 questions, the student has to answer any 4, each question carries 5 marks.
- **Section – B** contains 8 essay questions; the student has to answer any 5 questions. Each question carries 10 marks.

The Question papers setters are requested to cover all the topics in the syllabus as per the weightage given by us.

SEMESTER – V	COURSE CODE : PHY-502
PAPER TITLE : Modern Physics (<u>Model Paper</u>)	

Duration : 3Hours

Maximum marks : 70

Pass marks : 28 marks

III B.Sc. Physics – V Semester – Paper –VI (2020 – 2021)
Modern Physics

Paper Code : PHY 502C

SECTION-A

Answer any FOUR questions

(4x5=20M)

1. Write the Draw backs of Bohr's atomic model.
2. Explain deBroglie concept of matter waves.
3. Explain Geiger-Nuttal law.
4. Write a note on liquid drop model.
5. Explain Meissner effect in super conductivity.
6. State postulates of Quantum Mechanics.
7. In a crystal lattice plane cuts intercepts $2a$, $3b$ and $6c$ along the three axes where a, b and c are primitive vectors of the unit cell. Determine the miller indices of the given plane.
8. If the uncertainty in position of an electron is $4 \times 10^{-10} \text{m}$ and uncertainty in its momentum is $1.65 \times 10^{-24} \text{kg m/sec}$.

SECTION-B

Answer any FIVE questions :

(5x10=50M)

9. Describe Stern and Gerlach experiment and discuss the importance of the results obtained
10. What is Raman Effect? Write the Experimental setup to study Raman Effect.
11. Describe Davisson and Germer Experiment on electron diffraction. Discuss the results of the Experiment.
12. Derive Time independent Schrodinger wave equation.
13. Calculate the energy of a particle in one dimensional box using Schrodinger equation.
14. Mention the Basic Properties of Nucleus with reference to Size, Charge, Mass, Nuclear spin and Electric Quadra pole Moment.
15. Describe X-Ray diffraction by Laue's method.
16. Explain Type-I and Type-II Superconductors.

Practical Paper VI : Modern Physics

Exam duration : 3Hours Maximum marks : 50 marks

Work load : 30 hrs

3 hrs.

Minimum of 6 experiments to be done and recorded

1. e/m of an electron by Thomson method.
2. Determination of Planck's Constant (photocell)
3. Verification of inverse square law of light using photovoltaic cell.
4. Study of absorption of α – rays.
5. Study of absorption of β – rays.
6. Determination of range of β – particles.
7. Determination of M & H .
8. Analysis of powder X- ray diffraction pattern to determine properties of crystals.
9. Energy gap of semiconductor using junction diode.
10. Energy gap of a semiconductor using Thermistor.

**A.G& S.G.SIDDHARTHA DEGREE COLLEGE OF ARTS &
SCIENCE**

VUYYURU-521165, KRISHNA Dt., A.P.(Autonomous)

Accredited by NAAC with "A" Grade

2021-2022



**DEPARTMENT OF PHYSICS
MINUTES OF BOARD OF STUDIES**

EVEN SEMESTER







30-03-2022

Minutes of the meeting of Board of studies in Physics for the Autonomous course of A.G. & S.G. Siddhartha Degree College of Arts & Science, Vuyyuru held at 10.30 A.M on 30 - 03 - 2022 in the Department of Physics.

Sri J.Hareesh Chandra

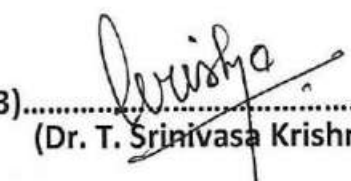
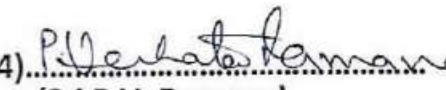
Presiding

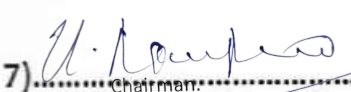
Members Present:

- 1).......... Chairman Head, Department of physics(I/C)
(Sri J. Hareesh Chandra) A.G. & S.G.S. Degree College of Arts&science, Vuyyuru - 521165
- 2).......... University Nominee Registrar
(Dr. M. Rami Reddy) Krishna University, Machilipatnam.
- 3).......... Academic Council Nominee Associate Professor,
(Dr. T. Srinivasa Krishna) H.O.D, Dept. of Physics,
P.B.Siddhartha college of arts & science,vijayawada Vijayawada.
- 4).......... Academic Council Nominee H.O.D, Dept. of Physics,
(Sri P.V. Ramana) A.J. Kalasala, Machilipatnam.
- 5).......... Representative from Sub Divisional Engineer, BSNL
(Sri I. Chittibabu) Industry Vijayawada.
- 6).......... Alumini Lecturer in Physics,
(Sri B. Dileep Kumar) Dept. of Physics, IIT, Nuzivid.
- 7).......... Member Lecturer in Physics,
(Sri U. Ram prasad) A.G. & S.G.S. Degree College of Arts & Science,
Vuyyuru - 521165.
- 8).......... Member Lecturer in Physics,
(Sri M. Sateesh) A.G. & S.G.S.Degree College of Arts & Science,
Vuyyuru - 521165.

9).....*M. Purva Durga Parimala*.....
(Smt. M.P.D. Parimala)

Member

Lecturer in Physics,
A.G. & S.G.S. Degree College of Arts
& Science, Vuyyuru - 521165.

10).....*J. Dileep*.....
(Sri J. Dileep)

Member

Lecturer in Physics,
A.G. & S.G.S. Degree College of Arts &
Science, Vuyyuru - 521165.

Agenda for B.O.S Meeting

1. To recommend the syllabi and model papers for II semester of I Degree B.Sc., Physics for the Academic year 2021-2022.
2. To recommend the syllabi and model papers for IV semester of II Degree B.Sc., Physics for the Academic year 2021-2022.
3. To recommend the syllabi and model papers for VI semester of III Degree B.Sc. Physics for the Academic year 2021-2022.
4. To recommend the Blue print of question papers for II, IV & VI semesters of B.Sc. Physics for the Academic year 2021-2022.
5. To recommend the Guidelines to be followed by the question paper setters in Physics for II, IV & VI Semester – end exams.
6. To recommend the teaching and evaluation methods to be followed under Autonomous status.
7. Any suggestions regarding seminars, workshops, Guest lecture to be organized.
8. Recommend the panel of paper setters and Examiners to the controller of Examinations of autonomous Courses of A.G. & S.G.S.Degree colleges of Arts & Science, Vuyyuru.
9. Any other matter.

Chairman.

RESOLUTIONS

- 1) It is resolved to follow the **changed syllabi and model papers for II semester of I B.Sc.** as per APSCH guidelines from the Academic year 2020-2021.
- 2) It is resolved to follow the **changed syllabi and model papers for IV semester of II B.Sc.** as per APSCH guidelines from the Academic year 2020-21.
- 3) It is resolved to follow
 - a) The same **syllabi and model papers** for elective paper “Analog and Digital Electronics” (PHY-601GE) under Choice Based Credit System (CBCS) for **VI semester of III B.Sc.**
 - b) The **same syllabi and model papers** for Cluster paper “Introduction to Microprocessor and Microcontroller” (PHY-602 CE) under Choice Based Credit System (CBCS) for **VI semester of III B.Sc.**
 - c) The same **syllabi and model papers** for Cluster paper “Computational Methods and Programming” (PHY-603 CE) under Choice Based Credit System (CBCS) for **VI semester of III B.Sc.**
 - d) The **same syllabi and model papers** for Cluster paper “Electronics Instrumentation” (PHY-604 CE) under Choice Based Credit System (CBCS) and Project work is introduced instead of Practical for 50 marks, for **VI semester of III B.Sc.**
- 4) It is resolved to follow the **changed Blue print of II semester of Degree I B.Sc.** for the Academic year 2021-2022.
 - It is resolved to follow the **changed Blue print** of IV semester of Degree II B.Sc. for the Academic year 2021-2022.
 - It is resolved to follow the **same Blue print** of VI semester of Degree III B.Sc. for the Academic year 2021-2022.
- 5) It is resolved to follow the **changed Guidelines of II semester of Degree I B.Sc.** for the Academic year 2021-2022.
 - It is resolved to follow the **changed Guidelines** of IV semester of II Degree B.Sc. for the Academic year 2021-2022.
 - It is resolved to follow the **same Guidelines** of VI semester of Degree III B.Sc. for the Academic year 2021-2022.
- 6) It is resolved to continue the following teaching and evolution methods for Academic year 2021-2022.

Teaching Methods:

Besides the conventional methods of teaching, we use modern technology i.e. using of LCD projector, U boards, virtual lab etc, for better understanding of concepts.

Evaluation of a student is done by the following procedure:

➤ **Internal Assessment Examinations:**

- For I B.Sc (sem II), out of 100 marks in each paper, 25 marks shall be allocated for internal assessment.
- For II B.Sc (sem IV) and III B.Sc (sem VI) out of 100 marks in each paper, 30 marks shall be allocated for internal assessment
- Out of these 25 marks, **20 marks are allocated for announced tests (i.e. IA-1 & IA-2)**. Two announced tests will be conducted and average of these two tests shall be deemed as the marks obtained by the student, **5 marks** are allocated for **assignment / class room seminars for II nd semester .**
- Out of these 30 marks, **20 marks are allocated for announced tests (i.e. IA-1 & IA-2)**. Two announced tests will be conducted and average of these two tests shall be deemed as the marks obtained by the student, **5 marks** are allocated on the basis of candidate’s **percentage of attendance**, **5 marks** are allocated for **assignment / class room seminars for IV and VI Semesters.**

➤ Semester – End Examination:

- The maximum marks for I B.SC, II Semester – End examination shall be 75 marks and duration of the examination shall be 3 hours.
- The maximum marks for II B.SC and III B.SC. Semesters – End examination shall be 70 marks and duration of the examination shall be 3 hours.
 - **Semester – End examinations** in theory papers and **practical Examinations** shall be conducted at the end of every semester **II, IV & VI** and Project work for Cluster paper PHY-604 CE instead of Practical, **for I, II & III B.Sc.**
- 7) Discussed and recommended for organizing **seminars, Guest lecturers, workshops** to upgrade the knowledge of students, for the approval of the academic council.
 - 8) Discussed and empowered the Head of the department of Physics to suggest the panel of paper setters and examiners to the controller of examinations.
 - 9) Nil.

H. S. Chandra
Chairman.

DEPARTMENT OF PHYSICS
A.G. & S.G.SIDDHARTHA DEGREE COLLEGE OF ARTS & SCIENCE
(AUTONOMOUS) , VUYYURU – 521 165

I B.Sc. 2nd Semester (2021-2022)

Paper II: Waves Optics

II SEMESTER

Work load: 60 hrs per semester

credits - 3

4 hrs/week

Course outcomes :

On successful completion of this course, the student will be able to:

- ❖ Understand the phenomenon of interference of light and its formation in (i) Lloyd's single mirror due to division of wave front and (ii) Thin films, Newton's rings and Michelson interferometer due to division of amplitude.
- ❖ Distinguish between Fresnel's diffraction and Fraunhofer diffraction and observe the diffraction patterns in the case of single slit and the diffraction grating.
- ❖ Describe the construction and working of zone plate and make the comparison of zone plate with convex lens.
- ❖ Explain the various methods of production of plane, circularly and polarized light and their detection and the concept of optical activity..
- ❖ Comprehend the basic principle of laser, the working of He-Ne laser and Ruby lasers and their applications in different fields.
- ❖ Explain about the different aberrations in lenses and discuss the methods of minimizing them.
- ❖ Understand the basic principles of fiber optic communication and explore the field of Holography and Nonlinear optics and their applications.

UNIT-I Interference of light: (12hrs)

Division of Wave front: Introduction, Conditions for interference of light, Interference of light by division of wave front and amplitude, Phase change on reflection- Stokes' treatment, Fresnel's Bi-Prism-Determination of Wavelength of Light.

Division of Amplitude: Cosine law - colors in thin films, Newton's rings in reflected light- Theory and experiment - Determination of wavelength of monochromatic light, Michelson interferometer and determination of wavelength.

UNIT-II Diffraction of light: (12hrs)

Fraunhofer Class: Distinction between Fresnel and Fraunhofer diffraction, Fraunhofer diffraction at a single slit, Double slit and N-slits (No Derivation for N-Slits), Determination of wavelength of light using diffraction grating, Resolving power of grating,

Fresnel's Class: Fresnel's half period zones, Zone plate, comparison of zone plate with convex lens.

UNIT-III Polarisation of light: (12hrs)

Polarized light: Methods of production of plane polarized light -Polarisation by reflection (Brewster's law), Malus law, Double refraction, Nicol prism, Nicol prism as polarizer and analyzer

Types and production of polarized Light: Quarter wave plate, Half wave plate, Plane, Circularly and Elliptically polarized light-Production and detection, Optical activity, Laurent's half shade polarimeter: determination of specific rotation

UNIT-IV (12hrs)

Aberrations: Monochromatic aberrations - Spherical aberration, Methods of minimizing spherical aberration, Coma & Astigmatism -minimization methods, Chromatic aberration-the achromatic doublet; Achromatism for two lenses (i) in contact and (ii) separated by a distance.

Fibre Optics: Fibre optics: Introduction to Fibers, different types of fibers, rays and modes in an optical fiber, Principles of fiber communication (qualitative treatment only), Advantages of fiber optic communication.

UNIT-V Lasers and Holography: (12hrs)

Lasers: Introduction, Spontaneous emission, stimulated emission, Population Inversion, Laser principle, Einstein coefficients, Types of lasers-He-Ne laser, Ruby laser, Applications of lasers;

Holography: Basic principle of holography, Applications of holography

REFERENCE BOOKS:

- BSc Physics, Vol.2, Telugu Akademy, Hyderabad
- A Text Book of Optics-N Subramanyam, L Brijlal, S.Chand&Co.
- Optics-Murugesan, S.Chand&Co.
- Unified Physics Vol.IIOptics, Jai PrakashNath&Co.Ltd.,Meerut
- Optics,F.A. Jenkins and H.G.White,McGraw-Hill
- Optics,AjoyGhatak,TataMcGraw-Hill.
- Introduction of Lasers – Avadhanulu, S.Chand&Co.
- Principles of Optics- BK Mathur, Gopala Printing Press,1995

Practical Course II : Wave Optics

Workload:30hrs

2 hrs/week

Course outcomes (Practicals) :

On successful completion of this practical course the student will be able to,

1. Gain hands-on experience of using various optical instruments like spectrometer, polarimeter and making finer measurements of wavelength of light using Newton Ring experiment, diffraction grating etc.
2. Understand the principle of working of polarimeter and the measurement of specific rotatory power of sugar solution
3. Know the techniques involved in measuring the resolving power of telescope and dispersive power of the material of the prism.
4. Be familiar with the determination of refractive index of liquid by Boy's method and the determination of thickness of a thin wire by wedge method.

Minimum of 6 experiments to be done and recorded

1. Determination of radius of curvature of a given convex lens-Newton's rings.
2. Resolving power of grating.
3. Study of optical rotation-polarimeter.
4. Dispersive power of a prism.
5. Determination of wavelength of light using diffraction grating-minimum deviation method.
6. Determination of wavelength of light using diffraction grating-normal incidence method.
7. Resolving power of a telescope.
8. Refractive index of a liquid-hollow prism
9. Determination of thickness of a thin wire by wedge method
10. Determination of refractive index of liquid-Boy's method.

RECOMMENDED CO-CURRICULAR ACTIVITIES:

MEASURABLE

Assignments (in writing and doing forms on the aspects of syllabus content and outside the syllabus content. Shall be individual and challenging)

Student seminars (on topics of the syllabus and related aspects (individual activity))

Quiz (on topics where the content can be compiled by smaller aspects and data (Individuals or groups as teams))

Study projects (by very small groups of students on selected local real-time problems pertaining to syllabus or related areas. The individual participation and contribution of students shall be ensured (team activity))

GENERAL

Group Discussion

Visit to Research Stations/laboratories and related industries

RECOMMENDED ASSESSMENT METHODS

Some of the following suggested assessment methodologies could be adopted;

The oral and written examinations (Scheduled and surprise tests),

Practical assignments and laboratory reports,

Efficient delivery using seminar presentations,

Viva voce interviews.

DEPARTMENT OF PHYSICS
A.G. & S.G.SIDDHARTHA DEGREE COLLEGE OF ARTS & SCIENCE
(AUTONOMOUS) , VUYYURU – 521 165
II B.Sc. 4th Semester (2021-22)

Paper IV: ELECTRICITY, MAGNETISM AND ELECTRONICS

Work load:60 hrs per semester

credits - 3

4 hrs/week

Course outcomes & Objectives :

On successful completion of this course, the students will be able to:

- ❖ Understand the Gauss law and its application to obtain electric field in different cases and formulate the relationship between electric displacement vector, electric polarization, Susceptibility, Permittivity and Dielectric constant.
- ❖ Distinguish between the magnetic effect of electric current and electromagnetic induction and apply the related laws in appropriate circumstances.
- ❖ Understand Biot and Savart's law and Ampere's circuital law to describe and explain the generation of magnetic fields by electrical currents.
- ❖ Develop an understanding on the unification of electric and magnetic fields and Maxwell's equations governing electromagnetic waves.
- ❖ Phenomenon of resonance in LCR AC-circuits, sharpness of resonance, Q factor, Power factor and the comparative study of series and parallel resonant circuits.
- ❖ Describe the operation of p-n junction diodes, zener diodes, light emitting diodes and transistors
- ❖ Understand the operation of basic logic gates and universal gates and their truth tables.

UNIT-I

Electrostatics: (6hrs)

Gauss's law-Statement and its proof, Electric field intensity due to (i) uniformly charged solid sphere and (ii) an infinite conducting sheet of charge, Deduction of Coulomb's law from Gauss law, Electrical potential–Equipotential surfaces, Potential due to a (i)point charge (ii)uniformly charged sphere

Dielectrics: (6 hrs)

Dielectrics-Polar and Non-polar dielectrics- Electric displacement D, electric polarization P,Relation between D, E and P, Dielectric constant and electric susceptibility.

UNIT-II

Magnetostatics: (6 hrs)

Biot-Savart's law and its applications: (i) calculation of B due to long straight wire and (ii) solenoid, Ampere's Circuital Law and its application to Solenoid, Hall effect, determination of Hall coefficient and applications.

Electromagnetic Induction: (6 hrs) Faraday's laws of electromagnetic induction, Lenz's law, Self-induction and Mutual induction, Self-inductance of a long solenoid, Mutual inductance of two coils, Energy stored in magnetic field, Eddy currents and Electromagnetic damping

UNIT-III

Alternating currents: (6 hrs) Alternating current - Relation between current and voltage in LR and CR circuits, Phasor and Vector diagrams, LCR series and parallel resonant circuit, Q-factor, Power in ac circuits, Power factor.

Electromagnetic waves-Maxwell's equations: (6 hrs) Idea of displacement current, Maxwell's Equations-Derivation, Maxwell's wave equation (with derivation), Transverse nature of electromagnetic waves, Poynting theorem (Statement and proof)

UNIT-IV

Basic Electronic devices: (12 hrs)

Diodes: PN junction diode, Zener diode and Light Emitting Diode (LED) and their I-V characteristics, Zener diode as a regulator

Transistors: Transistors and its operation, CB, CE and CC configurations, Input and output characteristics of a transistor in CE mode, Relation between alpha, beta and gamma; Hybrid parameters, Determination of hybrid parameters from transistor characteristics; Transistor as an amplifier.

UNIT-V :

Digital Electronics : (12 hrs)

Number systems, Conversion of binary to decimal system and vice versa, Binary addition & Binary subtraction (1's and 2's complement methods), Laws of Boolean algebra, Basic logic gates, DeMorgan's laws-Statements and Proofs, NAND and NOR as universal gates, Exclusive-OR gate, Half adder and Full adder circuits.

REFERENCE BOOKS

- ❖ BSc Physics, Vol.3, Telugu Akademy, Hyderabad.
- ❖ Electricity and Magnetism, D.N. Vasudeva. S. Chand & Co.
- ❖ Electricity and Magnetism, B.D.Duggal and C.L.Chhabra. Shobanlal & Co.
- ❖ Electricity, Magnetism with Electronics, K.K.Tewari, R.Chand & Co.,

- ❖ Electricity and Magnetism, R.Murugesan, S. Chand & Co.
- ❖ Principles of Electronics, V.K. Mehta, S.Chand& Co.,
- ❖ Digital Principles and Applications, A.P. Malvino and D.P.Leach, McGrawHill Edition.

PAPER TITLE: Electricity, Magnetism and Electronics

Paper- V Semester – V Maximum marks: 70 marks Duration: 3Hours

Weightage for the question paper

Syllabus	Section-A (Short answer questions)	Section-B (essay questions)
Unit-1 (25 Marks)	T	2
Unit-2 (20 Marks)	T+P	1
Unit-3 (30Marks)	T+P	2
Unit-4 (20 Marks)	T+T	1
Unit-5 (25 Marks)	T	2

Note: **T** means one theory question, **P** means one problem

- **Section-A** contains **6** short questions and **2** problems out of these **8** questions, the student has to answer any **4**, each question carries **5** marks.
- **Section –B** contains **8** essay questions, the student has to answer any **5** questions, each question carries **10** marks.
- The Question papers setters are requested to cover all the topics in the syllabus as per the weightage given by us.

SEMESTER – V	COURSE CODE : PHY- 501 C
PAPER TITLE : Electricity, Magnetism and Electronics	

Duration : 3Hours Maximum marks : 70 Pass marks : 28 marks

MODEL PAPER

A.G. & S.G.SIDDHARTHA DEGREE COLLEGE OF ARTS & SCIENCE
(AUTONOMOUS), VUYYURU – 521 165

III B.Sc. (PHYSICS)- V SEMESTER
ELECTRICITY, MAGNETISM AND ELECTRONICS

TIME: 3 Hrs PHY – 501 C MAX MARKS: 70 PASS MARK : 28

.....
SECTION – A

ANSWER ANY FOUR OF THE FOLLOWING (4 X 5 = 25 M)

- 1) Write a short note on equi - potential surfaces
- 2) obtain an expression for energy stored in a magnetic field
- 3) Derive expression for power in ac circuit
- 4) Explain CE configuration of a transistor
- 5) Explain briefly how a transistor works as an amplifier
- 6) Explain about half adder circuit with truth table.
- 7) Calculate the intensity of the magnetic field at the center of a circular coil of radius 20 cm and 40 turns having a current of 2A in it.
- 8) In a series RLC circuit $R = 100 \text{ ohm}$, $L = 0.5\text{H}$ and $C = 0.4 \mu\text{F}$. calculate resonant frequency

SECTION – B

ANSWER ANY FIVE OF THE FOLLOWING QUESTIONS (5 X 10 = 50 M)

- 9) Derive an expression for the electric field due to uniformly charged sphere using Gauss law?
- 10) Define D, E and P derive the relation between them
- 11) Calculate the magnetic induction due to a long straight wire using Biot- savart's law
- 12) State and prove pointing theorem
- 13) Explain the growth and decay of charge in LR- circuit
- 14) Describe the construction and working of Zener diode.
- 15) State and prove De Morgan's theorem with examples.
- 16) Explain about basic logic gates with truth tables.

Practical CourseIV:Electricity, Magnetism and Electronics

Work load: 30 hrs 2 hrs/week Course outcomes (Practicals):

On successful completion of this practical course the student will be able to;

- ❖ Measure the current sensitivity and figure of merit of a moving coil galvanometer.Observe the resonance condition in LCR series and parallel circuit
- ❖ Learn how a sonometer can be used to determine the frequency of AC-supply.
- ❖ Observe the variation of magnetic field along the axis of a circular coil carrying current using Stewart and Gee's apparatus.
- ❖ Understand the operation of PN junction diode, Zener diode and a transistor and their V-I characteristics.
- ❖ Construct the basic logic gates, half adder and full adder and verify their truth tables. Further, the student will understand how NAND and NOR gates can be used as universal building blocks.

Minimum of 6 experiments to be done and recorded

1. LCR circuit series -resonance, Q factor.
2. LCR parallel circuit - resonance, Q factor.
3. Determination of ac-frequency –Sonometer.
4. Verification of Kirchoff's laws
5. Field along the axis of a circular coil carrying current-Stewart & Gee's apparatus.
6. PN Junction Diode V-I Characteristics
7. Zener Diode –V-I Characteristics
8. Logic Gates- OR, AND, NOT and NAND gates. Verification of Truth Tables.

9. Verification of De Morgan's Theorems.
10. Construction of Half adder and Full adders-Verification of truth tables
11. Zener Diode as a voltage regulator
12. Transistor CE Characteristics- Determination of hybrid parameters
13. Figure of merit of a moving coil galvanometer.

RECOMMENDED CO-CURRICULAR ACTIVITIES:

MEASURABLE

- ❖ Assignments (in writing and doing forms on the aspects of syllabus content and outside the syllabus content. Shall be individual and challenging)
- ❖ Student seminars (on topics of the syllabus and related aspects (individual activity))
- ❖ Quiz (on topics where the content can be compiled by smaller aspects and data (Individuals or groups as teams))
- ❖ Field studies (individual observations and recordings as per syllabus content and related areas (Individual or team activity))
- ❖ Study projects (by very small groups of students on selected local real-time problems pertaining to syllabus or related areas. The individual participation and contribution of students shall be ensured (team activity))

GENERAL

- ❖ Group Discussion
- ❖ Visit to Research Stations/laboratories and related industries
- ❖ Others

RECOMMENDED ASSESSMENT METHODS

Some of the following suggested assessment methodologies could be adoptee

- The oral and written examinations (Scheduled and surprise tests),
- Practical assignments and laboratory reports,
- Observation of practical skills,
- Efficient delivery using seminar presentations,

Viva voce interviews

DEPARTMENT OF PHYSICS
A.G. & S.G.SIDDHARTHA DEGREE COLLEGE OF ARTS &
SCIENCE
(AUTONOMOUS) , VUYYURU – 521 165
II B.Sc. 4th Semester (2020-21)

Paper IV: MODERN PHYSICS

Work load:60 hrs per semester

credits - 3

4 hrs/week



➤ Course Description: students would know about the basic principles in the development of modern physics. The topics covered in the course build a basic foundation of undergraduate physics students to study the advance branches: quantum physics, nuclear physics and particle physics. The course contains the study of atomic models, spectroscopy, matter waves, Schrodinger wave equations, brief idea of nuclear physics, and superconductivity. The students have the opportunity to use the basic principles of condensed matter physics in frontier areas of research and development in the field of material science, nanoscience and nanotechnology.

➤ Course Objectives:

➤ 1. To learn the concepts in Atomic Physics.

➤ 2. Review the experiments that led development of quantum theory

➤ 3. Understand the underlying foundations and basic principles of quantum mechanics

➤ 4. impart knowledge of the nuclear processes that yield nuclear energy

➤ 5. Acquire the knowledge of Nano materials

➤ Course outcomes: On successful completion of this course, the students will be able to:

- CO1 Remember the different atomic models and basic knowledge of spectroscopy
- CO2 Understand the theory and application of microwave, infrared and Raman spectroscopy
- CO3 Apply non- relativistic Schrödinger wave mechanics to a variety of potentials in one and three dimensions.
- CO4 Analyse the prerequisite in a molecule towards its Rotational and vibrational activity
- CO5 Examine the basic properties of nuclei, characteristics of Nuclear forces, salient features

➤ **SYLLABUS**

➤ **UNIT-I**

- A. Atomic Physics: (07 hrs) Vector atom model and Stern-Gerlach experiment, Quantum numbers associated with it, Angular momentum of the atom, Coupling schemes, Selection rules, Intensity rules, Spectral terms and spectral notations, Fine structure of Sodium D-lines, Zeeman effect, Experimental study of Zeeman effect
- B. Molecular Physics (05 hrs) Raman effect, Characteristics of Raman effect, Experimental study of Raman effect, Quantum theory of Raman effect, Applications of Raman effect.

➤ **UNIT-II**

- A. Matter waves & de-Broglie's hypothesis (06 hrs) Failures of Classical Mechanics, Matter waves – de-Broglie's hypothesis, Derivation for de-Broglie wave length of matter waves, Properties of matter waves, Davisson and Germer's experiment, Phase and group velocities (Qualitative),
- B. Uncertainty Principle and Quantization (06 hrs) Heisenberg's uncertainty principle for position and momentum (x and p), & energy and time (E and t), Illustration of uncertainty principle using diffraction of beam of electrons

(Diffraction by a single slit) and photons (Gamma ray microscope), Bohr's principle of complementarity.

➤ UNIT-III

- Quantum (Wave) Mechanics:(12 hrs) Basic postulates of quantum mechanics, Schrodinger time independent and time dependent wave equations - Derivations, Physical interpretation of wave function, Eigen functions, Eigen values, Application of Schrodinger wave equation to one dimensional potential box of infinite height (Infinite Potential Well)

➤ UNIT-IV

- A. Structure of Nuclei and Nuclear Models: (06 hrs) Nuclear Structure: General Properties of Nuclei, Mass defect, Binding energy; Nuclear forces, Characteristics of nuclear forces, Yukawa's meson theory (Qualitative), Nuclear Models: Liquid drop model, Shell model, Magic numbers.
- B. Elementary Particle Physics (06 hrs) Elementary Particles and their classification, Fundamental Interactions – gravitational, electromagnetic, strong & weak; Properties of Leptons, Mesons and Baryons

➤ UNIT-V

- A. Nano materials: (07hrs) Origin of Nano materials - Quantum confinement, Size effect, Surface to volume ratio, Classification of nano materials - (0D, 1D, 2D); Nano wires, Fullerene, CNT, Graphene (Mention of structures and properties), Distinct properties of nano materials (Mention-mechanical, optical, electrical, and magnetic properties); Applications of nano materials: (Fuel cells, Phosphors for HD TV, Sensors)
- B. Superconductivity: (05 hrs) Introduction – Properties of superconductors - critical temperature (T_c), critical magnetic field (T_m), Meissner effect, Isotope

effect, Type I and Type II superconductors, BCS theory (Qualitative), High T_c superconductors, Applications of superconductors.

TEXT BOOKS

- 1. BSc Physics, Vol.4, Telugu Akademy, Hyderabad
- 2. Modern Physics by R. Murugesan and Kiruthiga Siva Prasath. S. Chand & Co.
- 3. Nano materials, A K Bandopadhyay, New Age International Pvt Ltd (2007)

REFERENCE BOOKS:

- 1. Atomic Physics by J.B. Rajam; S. Chand & Co.,
- 2. Concepts of Modern Physics by Arthur Beiser. Tata McGraw-Hill Edition.
- 3. Nuclear Physics, D.C. Tayal, Himalaya Publishing House.
- 4. S.K. Kulkarni, Nanotechnology: Principles & Practices (Capital Publ.Co.)
- 5. K. K. Chattopadhyay & A.N. Banerjee, Introd.to Nanoscience and Technology (PHI Learning Priv. Limited).
- 5. Textbook of Nanoscience and Nanotechnology, BS Murthy, P Shankar, Baldev Raj, BB Rath and J Murday-Universities Press-IIM

PAPER TITLE: Modern Physics

Paper- VI Semester – V Maximum marks: 70 marks Duration: 3Hours
Weightage for the question paper

Syllabus	Section-A (Short answer questions)	Section-B (Essay questions)
Unit-1 (25 Marks)	T	2
Unit-2 (20 Marks)	T+P	1
Unit-3 (25Marks)	T	2
Unit-4 (20 Marks)	T+T	1
Unit-5 (30 Marks)	T+P	2

Note: **T** means one theory question, **P** means one problem

- **Section-A** contains **6** short questions and **2** problems out of these **8** questions, the student has to answer any **4**, each question carries

5 marks.

- **Section – B** contains 8 essay questions; the student has to answer any 5 questions. Each question carries 10 marks.

The Question papers setters are requested to cover all the topics in the syllabus as per the weightage given by us.

SEMESTER – V	COURSE CODE : PHY-502
PAPER TITLE : Modern Physics (<u>Model Paper</u>)	

Duration : 3Hours

Maximum marks : 70

Pass marks : 28 marks

III B.Sc. Physics – V Semester – Paper –VI (2020 – 2021)

Modern Physics

Paper Code : PHY 502C

SECTION-A

Answer any FOUR questions

(4x5=20M)

1. Write the Draw backs of Bohr's atomic model.
2. Explain deBroglie concept of matter waves.
3. Explain Geiger-Nuttal law.
4. Write a note on liquid drop model.
5. Explain Meissner effect in super conductivity.
6. State postulates of Quantum Mechanics.
7. In a crystal lattice plane cuts intercepts $2a$, $3b$ and $6c$ along the three axes where a, b and c are primitive vectors of the unit cell. Determine the miller indices of the given plane.
8. If the uncertainty in position of an electron is $4 \times 10^{-10} \text{m}$ and uncertainty in its momentum is $1.65 \times 10^{-24} \text{kg m/sec}$.

SECTION-B

Answer any FIVE questions :

(5x10=50M)

9. Describe Stern and Gerlach experiment and discuss the importance of the results obtained

10. What is Raman Effect? Write the Experimental setup to study Raman Effect.
11. Describe Davisson and Germer Experiment on electron diffraction. Discuss the results of the Experiment.
12. Derive Time independent Schrodinger wave equation.
13. Calculate the energy of a particle in one dimensional box using Schrodinger equation.
14. Mention the Basic Properties of Nucleus with reference to Size, Charge, Mass, Nuclear spin and Electric Quadra pole Moment.
15. Describe X-Ray diffraction by Laue's method.
16. Explain Type-I and Type-II Superconductors.



- LIBRARY ACTIVITY Student visit library to refer and gather information regarding seminar topics and assignments.
- Course Delivery method: Face-to-face / Blended
- Course has focus on: Foundation & Employability
- Course has focus on: Employability Websites of Interest:
- Co-curricular Activities: 1. Assignments
- 2. Student seminars
- 3. quiz

DEPARTMENT OF PHYSICS
**A.G. & S.G.SIDDHARTHA DEGREE COLLEGE OF ARTS &
SCIENCE**

(AUTONOMOUS), VUYYURU – 521 165

III B.Sc. Physics – VI Semester – Paper –VII (2021-2022)

Elective VII (A):

Course Code: PHY – 601GE

SEMISTER-VI

credits - 3

4 hrs/week

ELECTIVE PAPER –VII-A: ANALOG AND DIGITAL ELECTRONICS

UNIT- I (14 hours)

Total Lectures: 60 hours

1. FET Construction ,Working ,Characteristics and uses; MOSEFT-enhancement MOSEFT,Depletion MOSEFT, Construction and Working, drain Characteristics of MOSEFT, applications of MOSEFT.
2. Photo electric devices: structure and operation, Characteristics and applications of LED and LCD.

UNIT- II (10hours)

3. Operational amplifier: Characteristics of ideal and practical OP-amp (IC-741),Basic differential OP-amp supply voltage, IC identification, internal blocks of OP-amp, its parameter off set voltages and currents, CMRR, slew rate, Concept of Virtual ground.

UNIT- III (10hours)

4. Applications of OP-amp: OP-amp as voltage amplifier, inverting amplifier, Non- inverting amplifier, Voltage follower, summing amplifier, difference amplifier, comparator, Integrator, Differentiator.

UNIT- IV (14hours)

5. Data processing circuits: Multiplexers, De –Multiplexers, encoders, decoders, Characteristics

6.For Digital IC's –RTL, DTL,TTL, CMOS (NAND&NOR Gates).

UNIT- V (12hours)

1. Sequential digital circuits: Flip-flops, RS, clocked SR, JK, D, T, Master-Slave Flip-flops .
2. Counters: Asynchronous counters-modulo 4counter-modulo 16 ripple counter, Decade counter, Synchronous counter.

REFERENCE BOOKS :

1. Digital Electronics by G.K.Kharate Oxford University Press.
2. Unified Electronics by Agarwal and Agarwal.
3. OP-Amp and Linear ICs by Ramakanth A Gayekward, 4th edition PHI
4. Digital Principles and Applications by Malvino and Leach, TMH, 1996, 4th edition.
5. Digital Circuit design by Moris Mano, PHI.
6. Switching theory and Logic design by A.Anand kumar, PHI
7. Operations amplifier by S.V.Subramanyam.

The Guidelines to be followed by the question paper setters in Physics for the VI Semester - end exams

PAPER TITLE: (ELECTIVE PAPER –VII-A): ANALOG AND DIGITAL ELECTRONICS

Paper- VII-A Semester – VI Maximum marks: 70 marks
Duration: 3Hours

Weightage for the question paper

Syllabus	Section-A (Short answer questions)	Section-B (Essay questions)
Unit-1 (24 Marks)	T	2
Unit-2 (18 Marks)	T+P	1
Unit-3 (28Marks)	T+P	2
Unit-4 (18Marks)	T+T	1
Unit-5 (24Marks)	T	2

Note: T means one theory question, P means one problem

- **Section-A** contains **6** short questions and **2** problems out of these **8** questions, the student has to answer any **5**, each question carries **4** marks.
- **Section – B** contains **8** essay questions, the student has to answer any **5** questions. Each question carries **10** marks.

The Question papers setters are requested to cover all the topics in the syllabus as per the weightage given by us.

SEMESTER – V	COURSE CODE : PHY-601 GE
PAPER TITLE : ELECTIVE PAPER –VII-A: ANALOG AND DIGITAL ELECTRONICS	

Duration : 3Hours Maximum marks : 70 Pass marks : 28 marks

Model paper –VII(A) Elective (Electronics)

Semester -VI

Elective Paper –VII-(A): Analog and Digital Electronics

SECTION-A

Time:3hr

Max.marks:70

Answer any five of the following questions:

5x4=20M

1. Discuss the advantages of FET over BJT.
2. Explain the concept of Virtual Ground.
3. Describe the concept of OP-amp Summing amplifier.
4. The summing amplifier as $R_o=10K$, $R_1=10K$, $R_2=5K$, $R_3=6K$. If $V_1=6V$, $V_2= -3V$, $V_3= -0.8V$. Calculate V_0 ?
5. Explain the Working of Demultiplexer with circuit diagram.
6. Explain the working of TTL logic.
7. Explain the working of RS Flip flop .Write its Truth Table.
8. Find the gain of inverting amplifier with given data. $R_1= 5000\Omega$, $R_f= 60 K\Omega$.

SECTION-B

Answer any five of the following questions:

10x5=50M

9. Explain the construction , Working and V-I Characteristics of JFET.
10. Describe Construction and Working Of LED. Mention its application.
11. What are the Characteristics of an ideal OP-amp .Draw the block diagram of OP-amp. Define the term CMRR and Slew rate.
12. Derive the Expression per Closed loop Gain of an inverting Amplifier. Explain how OP-amp acts as an Integrator.
- 13.Explain the working of Integrator, Differentiator.
14. What is a Multiplexer? Explain its Working and Analogy.
15. Describe the Working of Master Slave JK Flip flop. Give its Truth Table.
16. Explain Asynchronous counter and Synchronous counter.

**ELECTIVE PAPER –VII PRACTICAL: ANALOG AND DIGITAL
ELECTRONICS**

credits – 2

2 Hours per week

Minimum of 6 experiments to be done and recorded

1. Characteristics of FET
2. Characteristics of MOSEFT
3. Characteristics of LDR
4. Characteristics of OP-amp.(IC-741)
5. OP-amp as amplifier/inverting amplifier
6. OP-amp as integrator/differentiator
7. OP-amp as summing amplifier /difference amplifier
8. Master-Slave Flip-flop
9. JK Flip-flop

DEPARTMENT OF PHYSICS
**A.G. & S.G.SIDDHARTHA DEGREE COLLEGE OF ARTS &
SCIENCE**

(AUTONOMOUS), VUYURU – 521 165

III B.Sc. Physics – VI Semester – Paper –VIII (2020-21)

SEMISTER-VI Course Code: PHY -602 CE

credits - 3

4 hrs/week

CLUSTER ELECTIVES VIII-A

**PAPER-VIII-A-1: INTRODUCTION TO MICROPROCESSOR AND
MICROCONTROLLER**

UNIT- I (10hours)

MICROPROCESSOR:

General architecture of microprocessor, architecture of 8085 microprocessor, 8085 pin diagram, Concept of data bus, address bus, and control bus, 8085 programming instruction classification.

UNIT-II: (10hours)

8085 Interfacing Memory

Introduction-Memory structure and its requirements-basic concepts in memory interfacing. Address Decoding-Interfacing circuit. Port-mapped I/O or Direct I/O interface (8-bit Addressing)-Memory Indirect I/O mapped Interfaces (16-bit Addressing)-Port mapped versus Memory mapped I/O. I/O Device Interfacing.

UNIT-III (15hours)

8085 Microprocessor Applications

Introduction-Programmed data transfer scheme. Direct Memory Access (DMA) –Types. 8255A PPI-Block diagram. 8259A PIC-Pin diagram and functional description. 8257 Programmable DMA controller-Block diagram and Pin description.

UNIT-IV: (13hours)

8051 Architecture-I:

Types of microcontrollers- microcontroller architecture, CISC, RISC, operation of microcontroller, basic building blocks of microcontroller, comparison of microcontroller and microprocessor- block diagram of 8051-I/o pins and ports.

Microcontroller Resources.

UNIT-V: (12hours)

8051 Architecture-II:

8051 Flag bits and PSW register and DPTR register- Memory Organization-Special function registers- PSW register-Counters and Timers-Serial I/O-8051 Microcontroller Interrupts.

REFERENCE BOOKS:

1. Unified Electronics – VI(A), Micro controllers and applications
2. THE 8051 micro controller and embedded systems using assembly and C, M.A. Mazidi, J.G.Mazidi and R.D.McKinlay second Ed.,2007 Pearson education India.
3. Unified Electronics – V(A),Microprocessor (Intel 8085)
4. Micro controllers in practice, I susena and Mitescu, 2005, Springer.

The Guidelines to be followed by the question paper setters in Physics for the VI Semester - end exams

CLUSTER ELECTIVES VIII-A**PAPER-VIII-A-1: INTRODUCTION TO MICROPROCESSOR AND MICROCONTROLLER**

Paper- VIII-A-1 Semester – VI Maximum marks:70 Duration: 3Hours

Weightage for the question paper

Syllabus	Section-A (Short answer questions)	Section-B (Essay questions)
Unit-1 (28 Marks)	T+T	2
Unit-2 (14Marks)	T	1
Unit-3 (28Marks)	T+T	2
Unit-4 (24Marks)	T	2
Unit-5 (18 Marks)	T+T	1

Note: T means one theory question.

- **Section-A** contains **8** short questions, out of these **8** questions, the student has to answer any **5**, each question carries **4** marks.
- **Section – B** contains **8** essay questions, the student has to answer any **5** questions. Each question carries **10** marks.

The Question papers setters are requested to cover all the topics in the syllabus as per the weightage given by us.

SEMESTER – VI	COURSE CODE : PHY-602 CE
PAPER TITLE : CLUSTER ELECTIVES VIII-A	
PAPER-VIII-A-1: INTRODUCTION TO MICROPROCESSOR AND MICROCONTROLLER	

Duration : 3Hours

Maximum marks : 70

Pass marks : 28 marks

Model Paper- Sem VI

III B.Sc - PHYSICS (cluster) – VI SEMESTER

INTRODUCTION TO MICROPROCESSOR AND MICROCONTROLLERS

PHY- 602 CE

Max marks : 70

SECTION-A

Answer any FIVE of the following questions :

(5x4=20M)

- 1) Define data bus and address bus.
- 2) Define Address Decoding.
- 3) Write a short note on asynchronous data transfer scheme.
- 4) What is direct access memory?
- 5) Write about CISC.
- 6) Write about operation of microcontroller.
- 7) Write about program memory.
- 8) Write about memory expansion.

SECTION – B

Answer any FIVE of the following questions :

(5x10 = 50 M)

- 9) Describe the general architecture of Microprocessor.
- 10) Draw the 8085 Microprocessor pin diagram and explain about different pins.
- 11) Discuss about Direct I/O interface of 8-bit?
- 12) Give the functional description of 8259A.
- 13) Describe the Block diagram of 8255A.
- 14) Draw the pin diagram of 8051 and briefly describe the pins.
- 15) Write the basic building blocks of microcontroller.
- 16) Write short notes on
 - a) R-registers
 - b) Program status word register
 - c) Data Pointer register.

PAPER-VIII-A-1: Practical: INTRODUCTION TO MICROPROCESSOR AND MICROCONTROLLER credits – 2 2 Hours per week

Minimum of 6 experiments to be done and recorded

1. To find that the given number is prime or not.
2. To find the factorial of a number.
3. Write a program to make the two numbers equal by increasing the smallest number and decreasing the largest number.
4. Use one of the four parts of 8051 for O/P interfaced to eight LED's simulate binary counter (8 bit) on LED's.
5. Program to glow first four LED then next four using TIMER application.
6. Program to rotate the contents of the accumulator first right and then left.
7. Program to run a count down from 9-0 in the 7 segment LED display.
8. To interface 7 segment LED display with 8051 Microcontroller and display 'HELP' in the 7 segment LED display.
9. To toggle '1234' as '1324' in the 7 segment LED.
10. Interface stepper motor with 8051 and write a Program to move the motor through a given angle in clock wise or counter clock wise direction.
11. Application of Embedded system: Temperature measurement, some information on LCD display, interfacing a key board.

**A.G. & S.G.SIDDHARTHA DEGREE COLLEGE OF ARTS &
SCIENCE**

III B.Sc. 6th Semester (2020-21)

COURSE CODE : PHY-603 CE credits - 3

Cluster Elective Paper – VIII- A-2 : Computational Methods and Programming

No. of Hours per week : 04

Total Lectures : 60

UNIT – I (12 hrs)

1. Fundamentals of C language: C character set – Identifiers and keywords – structure of c program. Constants- variables- Data types- Declarations of variables – Declaration of storage class – Defining symbolic constants – Assignment statement.
2. Operators : Arithmetic operators- Relational operators – Logic operators – Assignment operators – Increment and decrement operators – Conditional operators.

UNIT –II (12 hrs)

3. Expressions and I/O statements : Arithmetic expressions – precedence of arithmetic operators – Type converters in expressions – Mathematical (Library) functions – Data input and output – The getchar and putchar functions – Scanf – Printf simple programs.
4. Control statements: IF – ELSE statements – Switch statements – The operators – GO TO- while, DO-While, FOR statements – BREAK and CONTINUE statements.

UNIT – III (12 hrs)

5. Arrays: One dimensional and two dimensional arrays – Initialization –Type declaration – Inputting and outputting of data for arrays – Programs of matrices addition, subtraction and multiplication.
6. User defined functions: The form of C functions – Return values and their types – Calling a function – Category of functions. Nesting of functions. Recursion. ANSI C functions – Function declaration. Scope and life of variables in functions.

UNIT – IV (12 hrs)

7. Linear and Non-Linear equations: Solution of Algebra and transcendental equations – Bisection, Falsi position and Newton – Rhapsom methods – Basic principles – Formulae – algorithms.
8. Simultaneous equations: Solutions of simultaneous linear equations – Guass elimination and Guass seidel iterative methods – Basic principles – Formulae- Algorithms.

UNIT – V (12 hrs)

- Interpolations : Concept of linear interpolation – Finite differences – Newton's and Lagrange's interpolation formulae – principles and Algorithms.
9. Numerical differentiation and integration : Numerical differentiation – algorithm for evaluation of first order derivatives using formulae based on Taylor's series – Numerical integration – Trapezodal and Simpson's 1/3 rule – Algorithms.

REFERENCE BOOKS :

- 1.Introductory methods of Numerical Analysis : SASTRY
2. Numerical Methods : Balaguruswamy
3. Programming in ANSI C (TMH) : Balaguruswamy
- 4.Programming with ‘C’ – Byron Gottafried, Tata Mc Graw Hill

The Guidelines to be followed by the question paper setters in Physics for the VI Semester - end exams

Cluster Elective Paper – **VIII- A-2** : Computational Methods and Programming

Paper- VIII-A-2 Semester – VI Maximum marks: 70 marks Duration: 3Hours

Weightage for the question paper

Syllabus	Section-A (Short answer questions)	Section-B (Essay questions)
Unit-1 (28Marks)	T+T	2
Unit-2 (28Marks)	T+T	2
Unit-3 (28Marks)	T+T	2
Unit-4 (14Marks)	T	1
Unit-5 (14 Marks)	T	1

Note: T means one theory question.

- **Section-A** contains **8** short questions, out of these **8** questions, the student has to answer any **5**, each question carries **4** marks.
- **Section – B** contains **8** essay questions, the student has to answer any **5** questions. Each question carries **10** marks.

The Question papers setters are requested to cover all the topics in the syllabus as per the weightage given by us.

SEMESTER – VI

COURSE CODE : PHY-603 CE

Duration : 3Hours

Maximum marks : 70

Pass marks : 28 marks

Model Paper :Sem VI
III B.Sc - PHYSICS (cluster) – VI Semester

COMPUTATIONAL METHODS AND PROGRAMMING

Paper Code : PHY 603 CE

Max.Marks : 70

SECTION-A

Answer any FIVE of the following questions : (5x4=20M)

- 1) Write different data types in C with Examples.
- 2) Structure of C program with Examples.
- 3) Explain about Puchar & getchar.
- 4) Explain about IF-Else Statement.
- 5) Define 2D array in C with example
- 6) Define Function with Examples.
- 7) Write the false position algorithm
- 8) Describe the Trapezoidal rule

SECTION-B

Answer any FIVE of the following questions : (5x10=50M)

- 9) Explain about storage classes in C
- 10) Explain different operators available in C
- 11) Explain about iterative statements in C.
- 12) Explain about Print f() & Scan f() function with examples.
- 13) Write a program for matrix multiplication
- 14) Explain about Recursion with example programme.
- 15) Explain about nesting of functions with example
- 16) Write the algorithm and flowchart of Newton Raphson formula.

Computational Methods and Programming

2 hrs/ week

credits - 2

Minimum of 6 experiments to be done and recorded

1. Write a program that reads an alphabet from keyboard and display in the reverse order.
2. Write a program to read and display multiplication of tablets.
3. Write a program for converting centigrade to Fahrenheit temperature and Fahrenheit temperature centigrade.
4. Write a program to find the largest element in an array.
5. Write a program based on percentage calculation , the grade by entering the subject marks . (If percentage > 60 , I class, if percentage between 50 & 60 II class, if percentage between 35 & 50 III class, if percentage below 35 fail)
6. Write a program for generation of even and odd numbers up to 100 using while, do – while and for loop.
7. Write a program to solve the quadratic equation using Bisection method.
8. Write a program for integration of function using Trapezoidal rule.
9. Write a program for solving the differential equation using Simpson's $1/3$ rule.

**A.G. & S.G.SIDDHARTHA DEGREE COLLEGE OF ARTS &
SCIENCE**

(AUTONOMOUS) , VUYYURU – 521 165

III B.Sc. 6th Semester (W.E.F 2020-21)

COURSE CODE : PHY-604 CE

Cluster Elective Paper – **VIII-A-3: Electronic Instrumentation**

No.of Hours per week: 04

Total Lectures: 60

UNIT -1 (12 Hours)

1. Basic of measurements: Instruments accuracy, precision, sensitivity- errors in measurements- Basic meter movement-PMMC (Permanent Magnetic Moving Coil).
2. Measurement of dc current: DC ammeter- multi range ammeters-the ARYTON Shunt or universal Shunt.
3. Measurement of dc voltage: DC Voltmeter – Multi Range Voltmeter- Voltmeter sensitivity.

UNIT – II (10 HOURS)

4. **Analog Multimeter:** Multimeter - as dc ammeter-as dc voltmeter-as ac voltmeter- as ohm meter-Multimeter operating instructions.
5. Digital instruments: Principle and working of digital instruments, characteristics of a digital meter, working principle of digital voltmeter.

UNIT –III (14 HOURS)

6. CRO: Block diagram of basic CRO, construction of CRT, electron gun, electrostatic focusing and acceleration (only explanation), time base operation, synchronization, front panel controls, specifications of CRO and their significance.
7. Applications CRO: Measurement of voltage- dc and ac, frequency, time period. Special features of dual trace CRO. Digital storage oscilloscope: block diagram and principle of working.

UNIT – IV (12 HOURS)

8. Diode as Rectifier – Half wave rectifier, Full wave rectifier – construction, working and efficiency. (no derivation)
9. Feedback in Electronic circuits – Positive and Negative feedback, expressions for gains, advantages of negative feedback, Oscillators, Barkhausen criteria, RC phase shift oscillator (no derivation)

UNIT – V (12 HOURS).

10. Signal Generators: Block diagram, working and specifications of low frequency signal generators, pulse generator, function generator .
11. Bridges: Measurement of resistance by Wheat stone's Bridge- Sensitivity of Wheat stone's Bridge- Applications of Wheat stone's Bridge-Limitations of Wheat stone's Bridge.

REFERENCE BOOKS :

1. A text book in electrical technology by B.L. Thereja (S.Chand & CO)
2. Digital circuits and systems by venugopal 2011 (Tata Mcgraw Hill)
3. Digital Electronics by SubrathaGoshal 2012 (Cengage Learning)
4. Electronic Instrumentation by HS Kalsi (Tata Mcgraw Hill)

The Guidelines to be followed by the question paper setters in Physics for the VI Semester - end exams

Cluster Elective Paper – **VIII-A-3: Electronic Instrumentation**

Paper- VIII-A-3 Semester – VI Maximum marks: 70 marks Duration: 3Hours

Weightage for the question paper

Syllabus	Section-A (Short answer questions)	Section-B (Essay questions)
Unit-1 (28Marks)	T+T	2
Unit-2 (18 Marks)	T+T	1
Unit-3 (28Marks)	T+T	2
Unit-4 (14 Marks)	T	1
Unit-5 (24 Marks)	T	2

Note: T means one theory question

- **Section-A** contains **8** short questions out of these **8** questions, the student has to answer any **5**, each question carries 4 marks.
- **Section – B** contains **8** essay questions, the student has to answer any 5 questions. Each question carries **10** marks.

The Question papers setters are requested to cover all the topics in the syllabus as per the weightage given by us.

PAPER TITLE : Cluster Elective Paper – VIII-A-3: Electronic Instrumentation

Duration : 3Hours

Maximum marks : 70

Pass marks : 28 marks

Model Paper :Sem VI
III B.Sc - PHYSICS (CLUSTER) – VI Semester
ELECTRONIC INSTRUMENTATION

Paper Code : PHY 604 CE

Max.Marks:70

SECTION-A

Answer any FIVE of the following questions : (5x4=25M)

- 1) Explain the following terms (a) precession (b) sensitivity.
- 2) Explain Multirange d.c voltmeter with a circuit diagram.
- 3) Write briefly the specifications of an electronic voltmeter.
- 4) Explain the function of various parts of an electronic gun.
- 5) Explain the time base operation of CRO.
- 6) Write the characteristics of a digital meter.
- 7) Explain the working of function generator.
- 8) What are the Limitations of Wheat stone's Bridge

SECTION-B

Answer any FIVE of the following questions : (5x10=50M)

- 9) Explain different types of errors that occur in measurements.
- 10) Explain the principles of voltage measurement with a block diagram.
- 11) Draw the basic block diagram of cathode ray oscilloscope and explain the functions of each block.
- 12) Explain with a block diagram the principle and working of digital storage oscilloscope .
- 13) Explain the working of a Multimeter as micro ammeter- as dc ammeter-as dc voltmeter-as ac voltmeter- as ohm meter
- 14) Explain the principle and working of digital instruments .
- 15) Explain the operation of a signal generator with the help of a suitable block diagram .
- 16) Explain the principle and working of Wheat stone's bridge .

Cluster Elective Paper – VIII-A-3-Practical: Electronic Instrumentation
2hrs/Week.

Paper Title: Project Work

Paper code: PHY-604 CE

The students have chosen Physics as cluster elective and “RECTIFIERS AND FILTER CIRCUITS BASED PROJECTS” for this Academic year.

Scheme of valuation

1. External : 25 marks given by the examiner (viva)
2. Internal : 25 marks
 - a) Written viva :10 marks
 - b) Submission of the Project book : 15 marksTotal = 50 marks

**A.G& S.G.SIDDHARTHA DEGREE COLLEGE OF ARTS &
SCIENCE**

VUYYURU-521165, KRISHNA Dt., A.P.(Autonomous)

Accredited by NAAC with "A" Grade

2021-2022



DEPARTMENT OF COMPUTER SCIENCE

MINUTES OF BOARD OF STUDIES

ODD SEMESTER

10-11-2021

Minutes of the meeting of Board of Studies in Computer Science for Semester I, III & V of I, II & III years B.Sc. (MPCs, MCCs, MSCs), B.Com. (C.A.) and B.Com (e-Commerce) Life Skill Course and Skill Development Course of AG & SG Siddhartha Degree College of Arts & Science, Vuyyuru, held at 9.30 A.M on 10-11-2021 in the Department of Computer Science.

Sri T.NagaPrasadaRao ... Presiding

Members Present:

- 1) T.NagaPrasadaRao Chairman Head, Department of Computer Science, AG & SG Siddhartha Degree College of Arts & Science.
- 2) Dr. M. Babu Reddy University Nomine Principal, Krishna University College of Engineering and Technology, Machilipatnam.
- 3) Dr. P. J. S Kumar Subject Expert Head, Department of Computer Science A.N.R College Gudivada.
- 4) Mr. K. Sridhar Subject Expert Deputy Head, Department of Computer Science PB Siddhartha College of Arts & Science, Vijayawada.
- 5) R. Sowjanya Industrial Expert .Net Developer, Maven Soft System Pvt. Ltd Madaapur, Hyderabad.
- 6) T. Keerthi Member Lecturer in Computer Science, AG & SG Siddhartha Degree College of Arts & Science, Vuyyuru
- 7) K Srikanth Member Lecturer in Computer Science, AG & SG Siddhartha Degree College of Arts & Science, Vuyyuru-521165.
- 8) S.Prabhavathi Member Lecturer in Computer Science, AG & SG Siddhartha Degree College of Arts & Science, Vuyyuru-521165
- 9) A. Sravani Member Lecturer in Computer Science, AG & SG Siddhartha Degree College of Arts & Science, Vuyyuru-521165
- 10) V.N.MalleswaraRao Member Lecturer in Computer Science, AG & SG Siddhartha Degree College of Arts & Science, Vuyyuru-521165
- 11) A. Naga Srinivasa Rao Member Lecturer in Computer Science, AG & SG Siddhartha Degree College of Arts & Science, Vuyyuru-521165
- 12) V. Murni Member Lecturer in Computer Science, AG & SG Siddhartha Degree College of Arts & Science, Vuyyuru-521165
- 13) K. Rajya Lakshmi Member Student in M.Sc. Computer Science, AG& SG Siddhartha Degree College of Arts & Science, Vuyyuru-521165
- 14) M. Jyothi Member Student in B.Sc. Computer Science, AG& SG Siddhartha Degree College of Arts & Science, Vuyyuru-521165

Agenda for B.O.S Meeting.

1. To Discuss and approve the Structure and Syllabi, Model Question Paper for first Semester of B.Sc.(MPCs, MCCs.MSCs) & B.Com (C.A), B.Com(e-Commerce) Programs for the student are admitted from the Academic Year 2021-22.
2. To Discuss and approve the Structure and Syllabi, Model Question Paper for Third Semester of B.Sc.(MPCs, MCCs.) & B.Com (C.A) Programs for the Academic Year 2021-22.
3. To Discuss and approve the Structure and Syllabi, Model Question Paper for Fifth Semester of B.Sc.(MPCs, MCCs.) & B.Com (C.A) Programs for the Academic Year 2021-22.
4. To recommend any changes in the syllabi for I, III, V Semesters of I, II, III year Degree B.Sc.(MPCs, MCCs, MSCs), B.Com.(C.A.) and B.Com(e-commerce).
5. To Introduce a New Programs for B.Sc (MSCs) and B.Com (e-commerce) from the Academic Year 2021-22.
6. To Introduce a Life Skill Course and Skill Development Course for all B.Sc and B.Com from the Academic Year 2021-22.
7. To recommend the teaching and evaluation methods to be followed under Autonomous status.
8. To recommend the panel of paper setters and examiners to the controller of the examinations of autonomous courses of AG & SG Siddhartha Degree College of Arts & Science College, Vuyyuru.
9. Any other matter

Resolutions.

- 1) It is Resolved and Recommended to adopt the structure and syllabi and Model Question Papers for first semester of B.Sc.(MPCs, MCCs, MSCs) & B.Com (C.A), B.Com(e-Commerce) Programs under CBCS(Choice Based Credit System) Approved by the Academic Council from the Academic Year 2021-22.
- 2) It is Resolved and Recommended to adopt the structure and syllabi and Model Question Papers for Third semester of B.Sc.(MPCs, MCCs) & B.Com (C.A), Programs under CBCS(Choice Based Credit System) Approved by the Academic Council from the Academic Year 2020-21
- 3) It is Resolved and Recommended to adopt the structure and syllabi and Model Question Papers for fifth semester of B.Sc.(MPCs, MCCs) & B.Com (C.A), Programs under CBCS(Choice Based Credit System) Approved by the Academic Council from the Academic Year 2020-21
- 4) It is Resolved and Recommend any changes in the syllabi for I, III, V Semesters of I, II, III year Degree B.Sc.(MPCs, MCCs, MSCs), B.Com.(C.A.) and B.Com(e-commerce).
 - **It is Resolved and Recommend change Syllabi and Model Question paper as per new regulations in I & III Semester of I & II Year Degree B.Sc. (MPCs, MCCs) and B.Com(CA).**
 - **It is Resolved and recommend NO changes in the syllabi for V Semester of III Year B.Sc. (MPCs, MCCs) & B.Com.(CA).**
 - **It is Resolved and recommend to Value Added Course on ARTIFICIAL INTELLIGENCE Course code AIVAC101 in SEMESTER III for Second Year Students.**
- 5) It is Resolved to implements New Programs for B.Sc (MSCs) and B.Com (e-commerce) from the Academic Year 2021-22.
- 6) It is Resolved to implements Life Skill Course and Skill Development Course for all B.Sc and B.Com from the Academic Year 2021-22.
- 7) It is resolved to continue the teaching and evaluation methods to be followed under Autonomous status.
- 8) It is resolved to continue the panel of paper setters and examiners to the controller of the examinations of autonomous courses of AG & SG Siddhartha Degree College of Arts & Science College, Vuyyuru.
- 9) Any other matter

Teaching methods:

Besides the conventional methods of teaching, we use modern technology i.e. Using of LMS and LCD projector to display on power board etc..for better understanding of concepts.

Evaluation of a student is done by the following procedure:

There are two components in the Valuation and Assessment of a student – Internal Assessment (IA) Semester Examinations (SE). **For the Batch of Students Admitted from 2021-22.**

Internal Assessment (IA)

- The maximum mark for IA is 25 and SE is 75 for theory; and for practical marks for IA 10 and 40 Marks for External Exam.
- Each IA written examination is of 1 hour 30 minutes duration for 20 marks. The tests will be conducted centrally. The average of two such IA is calculated for 20 marks.

- Other Innovative Components will be for 5 Marks. The innovative component is for 5 marks, conducted during the class hours by the staff member/ in charge of the subject, in the form of assignments/ quiz/ seminars /PPT/Online- assignments/Open Book/Viva Voce/ Group work/ Mini Project/ Exhibition, etc. The topic and time for submission/ presentation will be announced by the staff member/ in charge of the subject in advance. Each student should explain and defend his/her presentation.
- The semester examination will be of 3 hours with maximum 75 marks.
- There are no passing minimum marks for IA.

Internal Assessment (IA)

- The maximum mark for IA is 30 and SE is 70 for theory; and for practical marks for IA 10 and 40 Marks for External Exam.
- Each IA written examination is of 1 hour 30 minutes duration for 20 marks. The tests will be conducted centrally. The average of two such IA is calculated for 20 marks.
- Other Innovative Components will be for 5 Marks. The innovative component is for 5 marks, conducted during the class hours by the staff member/ in charge of the subject, in the form of assignments/ quiz/ seminars /PPT/Online- assignments/Open Book/Viva Voce/ Group work/ Mini Project/ Exhibition, etc. The topic and time for submission/ presentation will be announced by the staff member/ in charge of the subject in advance. Each student should explain and defend his/her presentation.
- For attendance 5 Marks are allotted.
- The semester examination will be of 3 hours with maximum 70 marks.
- There are no passing minimum marks for IA.

Semester Examinations (SE)

- A student should register himself/herself to appear for the Semester Examinations by payment of the prescribed fee.
- The Semester Examinations will be in the form of a comprehensive examination covering the entire syllabus in each subject. It will be of 3 hours duration & Foundation course 2 hours irrespective of the number of credits allotted to it.
- If a candidate fails to obtain pass marks even after the due to less mark in the IA examination, the marks of the next examination will be converted to be out of 100.
- Even though the candidate is absent for two IA exams/obtain zero marks the external marks are considered (if he/she gets 40/70) and the result shall be declared as 'PASS'.
- The maximum marks for each Paper shall be 100.

Question paper guide lines for Practical Examinations at the end of Semesters I, III & V Two Practical Programs to be conducted out of 15 programs at the end of Semester I, III & V Practical Examination time 3Hrs and Maximum Marks 50 Scheme of valuation Semesters – I, III & V B.Sc.& B.Com.(C.A),

Computer Science Practical's - External (Time: 3 hrs.)

Total Marks: 25M

1. Programs Writing (2) :	20 marks,
2. Viva voice :	5 marks
3. Execution & Result :	15 marks

Total Marks : 40

Computer Science Practical's- Internal

Total Marks: 10 M

1. Record : 10 marks

6.) Discussed and recommended for organizing Seminars, Guest lectures, Work-shops to upgrade the knowledge of students, for the approval of the Academic Council.

7) Discussed and empowered the HOD to suggest the panel of the paper setters and examiners to the controller of the examinations.

8). We implemented online certificate courses such as NPTL, APSSDC - PYTHON, R- Programming, Amazon Web services and JAVA -----etc. To fill the curriculum gaps from II year Degree on words

9). Suggestions

AG & SG SIDDHARTHA COLLEGE OF ARTS AND SCIENCES - VUYYURU.
An Autonomous college within the jurisdiction of Krishna University A.P, India.
(With Effect from Academic Year 2020-21)

COMPUTER SCIENCE	CSC-501C	2021-'22	B.Sc.(MPCs,MCCs)
-------------------------	-----------------	-----------------	-------------------------

SEMESTER – V

PAPER – V

Max. Marks 70

Syllabus: DATA BASE MANAGEMENT SYSTEMS

NO of Hours: 4

No Of Credits: 3

Pass Marks 28

Course Objective: Design & develop database for large volumes & varieties of data with optimized data processing techniques.

Unit – I: Database Systems Introduction**12Hrs**

Database Systems: Introducing the database and DBMS, Why the database is important,

Historical Roots: Files and File Systems, Problems with File System, Data Management, **Database Systems.** *Data Models:* The importance of Data models, Data Model Basic Building Blocks, The evaluation of Data Models, Degree of Data Abstraction.

Unit - II: Relational Database & Data Modelling**12 Hrs**

The Relational Database Model: A logical view of Data, Keys, Integrity Rules, Relational Set Operators, The Data Dictionary and the system Catalog, Indexes, Codd's relational database rules

.Entity Relationship Model: The ER Model *Advanced Data Modelling:* The Extended Entity Relationship Model, Entity clustering, Entity integrity.

Unit-III: Normalization and Database Design**14 Hrs**

Data base Tables and Normalization, The need Normalization, The Normalization Process, High level Normal Forms, Normalization and database design, de normalization.

Database Design: The Information System, The Systems Development Life Cycle, The Database Life Cycle, Centralized Vs Decentralized design.

Unit-IV: Structured Query Language**12 Hrs**

Introduction to SQL: Data Definition Commands, Data Manipulation Commands, Select queries, Advanced Data Definition Commands, Advanced Select queries, Virtual Tables, SQL Join Operators, Sub queries and correlated queries, SQL Functions.

Unit-V: Procedural SQL**10Hrs**

Introduction to PL/SQL: Triggers, Stored Procedures, PL/ SQL Stored Functions

Prescribed Text Book:

Peter Rob, Carlos Coronel, Database Systems Design, Implementation and Management, Seventh Edition, Thomson (2007).

Reference Books:

Elimasri / Navathe, Fundamentals of Database Systems, Fifth Edition, Pearson Addison Wesley 2. Raman A Mata – Toledo/Panline K Cushman, Database Management Systems, .

C.J.Date, Arkansan, S.Swamynathan, An Introduction to Database Systems, Eight edition,

“DatabaseSystemConcepts” by AbrahamSilberschatz, Henry Korth, and S.Sudarshan,

Atul Kahate, Introduction to Database Management Systems, Pearson Education (2006).

Student Activity: 1. Create your college database for placement purpose. 2. Create faculty database of your college with their academic performance scores

AG & SG SIDDHARTHA COLLEGE OF ARTS AND SCIENCES - VUYYURU.
An Autonomous college within the jurisdiction of Krishna University A.P, India.
(With Effect from Academic Year 2020-21)

COMPUTER SCIENCE	CSC-501C	2021-'22	B.Sc.(MPCs,MCCs)
-------------------------	-----------------	-----------------	-------------------------

SEMESTER – V

PAPER – V

Max. Marks 70

Model Paper: DATA BASE MANAGEMENT SYSTEMS

NO of Hours: 4

No Of Credits: 3

Pass Marks 28

Section-A

Answer any **FOUR** Questions. Each question carries **FIVE** Marks

4x5=20M

1. Explain the Components of Database System?
2. Explain Relational Data Model?
3. Write about Relational Set Operators?
4. Describe BCNF?
5. Write about Special Functions?
6. Explain Stored Procedures?

Section-B

Answer any **FIVE** Questions. Each question carries **TEN** Marks

5X10=50M

7. What is File? Explain the problems with File system
8. Explain the Degree of Data Abstraction
9. Explain E.F.CODDs' rules.
- 10.Explain Extended Entity Relationship Model
- 11.Explain the concept of Normal Forms
- 12.Explain about SDLC.
- 13.Explain DDL and DML commands.
- 14.Explain about triggers.

AG & SG SIDDHARTHA COLLEGE OF ARTS AND SCIENCES - VUYYURU.
An Autonomous college within the jurisdiction of Krishna University A.P, India.
(With Effect from Academic Year 2020-21)

COMPUTER SCIENCE	CSC-501C	2021-'22	B.Sc.(MPCs,MCCs)
------------------	----------	----------	------------------

SEMESTER – V PAPER – V Max. Marks 70 Pass Marks 28

Guidelines for paper setting '**DATA BASE MANAGEMENT SYSTEMS**'

Unit wise weight age of Marks

	Section-A (Short answer questions)	Section-B (essay questions)
Unit-1	2	2
Unit-2	1	2
Unit-3	1	2
Unit-4	1	1
Unit-5	1	1

- Each Short answer question carries 5 marks in Section –A
- Each Essay question carries 10 marks in Section –B
- The Question papers setters are requested to cover all the topics in the syllabus stipulated as per the weight age given by us

AG & SG SIDDHARTHA COLLEGE OF ARTS AND SCIENCES - VUYYURU.

An Autonomous college within the jurisdiction of Krishna University A.P, India.

(With Effect from Academic Year 2020-21)

COMPUTER SCIENCE	CSC-501P	2021-'22	B.Sc.(MPCS,MCCs)
-------------------------	-----------------	-----------------	-------------------------

SEMESTER – V

PAPER – V

Max. Marks 50

Lab List DATA BASE MANAGEMENT SYSTEMS

Pass Marks 25

No. of Hours per week: 2

External: 25

Internal: 25

Credits: 2

1. Creation of college database and establish relationships between tables
2. Explain various data type in Oracle.
3. Show the structure of the Emp table.
4. Show the structure of the DEPT table.
5. Explain the syntax of SELECT statement.
6. Create a query to display the name, job, hire date and employee number from emp table.
7. Create a query to display unique jobs from the emp table.
8. Create a query to display the empno as EMP#, ename as EMPLOYEE and Hire date from emp.
9. Create a query to display all the data from the EMP table. Separate each column by a comma and name the column THE_OUTPUT.
10. Create a query to display the name and salary of employees earning more than 2850.
11. Create a query to display the name and salary for all employees whose salary is not in the range of 1500 and 2850.
12. Display the employee name, job and start date of employees hired between February 20 ,1981 and May 1, 1981. Order the query in ascending order of start date
13. Display the employee name and department number of all the employees in departments 10 and 30 in alphabetical order by name.
14. List the name and salary of employees who earn more than 1500 & are in department 10 or 30.
15. Display the name, salary and commissions and sort data in descending order of salary and commission.
16. Display the name and job title of all employees who do not have a manager.
17. Display the name, job and salary for all employees whose job is Clerk or Analyst and their salary is not equal to 1000, 3000 or 5000.
18. Display the names of all employees where the third letter of their name is an 'A'.
19. Display the names of all employees who have two 'L's in their name and are in department 30 or their manager is 7782.
20. Display the name , salary and commission for all employees whose commission amount is grater than their salary increased by 10%.
21. Explain all the character functions.
22. Explain all the number functions.
23. Explain all the Date functions.
24. Explain different types of JOIN.
25. Write a query to display the name, department number and department name for all employees.
26. Create a unique listing of all jobs that are in department 30. and include the location of department 30 in the output.
27. Write a query to display the employee name, department name and location of all employees who earn a commission.
28. Write a query to display the name, job department number and department name for all employees who work in 'DALLAS'.
29. Create a query to display the name and hire date of any employee hired after employee BLAKE.

30. . Display all employees names and hire dates along with their manager's name and hire date for all employees who were hired before their managers.
 31. Create your own users and give permissions to you and explain GRANT and REVOKE Commands.
- A. Create MOVIE database using the following tables.

MOVIE: Movie no: primary key, varchar2
 Movie name: NOT NULL, varchar2
 Movie Type: varchar2
 Star: Varchar2

CUSTOMER: Customer No: primary key, varchar2
 Customer Name: NOT NULL, varchar2
 Address: NOT NULL
 Phone no: Number
 INVOICE: Invoice no: Varchar2, primary key
 Movie no: foreign key
 Customer no: foreign key
 Price: NOT NULL, Number

Queries:

1. List the movie names that starts with 'p'
2. List the number of the movies those price ranges from 15000 and 20000
3. List the customers who have phone numbers.
4. List the customers who have no phone numbers.
5. Display the following string
 (a) A Customer "customer number" has bought the "movie number" "movie name" with "Price"
6. List the customers by calculating price as $(price * tax) / 100$ where $tax = 0.5$ and rename the column as 'tax'.
7. List the movies, which are owned by 2 customers.
8. List the customers, who bought 2 picture names.
9. List the customers, who are not the range of 15000 and 20000.

B. Create Student database using the following tables.

STUDENT: Sno : primary key, number
 Sname : NOT NULL, varchar2
 Address: Varchar2

COURSE: Sno : Foreign key.
 Course Name : varchar2

Queries:

1. Alter table by adding a column fees in table COURSE.
2. Alter table by modifying the address to VARCHAR2(20)
3. Create a view on which the students who joined in one course only.

PL/SQL.

1. Write A Pl/Sql Program To Swap Two Numbers Without Using Third Variable.
2. Write A Pl/Sql Program To Generate Multiplication Tables For Numbers 2,4 And 6
3. Write A Pl/Sql Program To Display Sum Of Even Numbers And Sum Of Odd Numbers In The Given Range.
4. Write A Pl/Sql Program To Check The Given Number Is Pollinndrome Or Not.
5. Write A Pl/Sql Program To Display Top 10 Rows In Emp Table Based On Their Job And Salary.
6. Write A Procedure Update The Salary Of Employee, Who is Not Getting Commission by 10%.

Reference Books:

1. Oracle Pl/Sql By Example. Benjamin Rosenzweig, Elena Silvestrova, Pearson education 3rd Edition
2. Sql& Pl/Sql For Oracle 10g, Black Book, Dr.P.S. Deshpande

AG & SG SIDDHARTHA COLLEGE OF ARTS AND SCIENCES - VUYYURU.
An Autonomous college within the jurisdiction of Krishna University A.P, India.
(With Effect from Academic Year 2020-21)

COMPUTER SCIENCE	CSC-502C	2021-'22	B.Sc.(MPCs,MCCs)
-------------------------	-----------------	-----------------	-------------------------

SEMESTER – V

PAPER – VI

Max. Marks 70

Syllabus: SOFTWARE ENGINEERING

NO of Hours: 4

No Of Credits: 3

Pass Marks 28

Course Objectives

The Objective of the course is to assist the student in understanding the basic theory of software engineering, and to apply these basic theoretical principles to a group software development project.

UNIT-I: Introduction to Software Engineering & Process 12Hrs

The Evolving Role of Software– Software - The Changing Nature of Software, Software Myths, Legacy Software.

Process: Software Engineering-A Layered Technology - A Process Framework - The Capability Maturity Model Integration (CMMI) - Process Patterns, Process Assessments - Personal Software Process(PSP), Team Software Process (TSP).

Unit-II: Process Models 12Hrs

The Waterfall Models - Increment Process Models: The Increment Model, The RAD Model - Evolutionary Process Models: Prototyping, The Spiral Model, The Concurrent Development Model.

Unit-III: Requirements Engineering 14 Hrs

Requirements Engineering Tasks - Initiating The Requirements Engineering Process - Eliciting Requirements: Collaborative Requirements Gathering, Quality Function Deployment, User Scenarios, Elicitation Work Products - Negotiating Requirements - Validating Requirements.

Unit-IV: Design Engineering 10Hrs

Design Process And Design Quality - Design Concepts - The Design Model: Data Design Elements, Architectural Design Elements, Interface Design Elements, Component-Level Design Elements, Deployment -Level Design Elements.

Unit-V:SoftwareQuality: 12Hrs

Quality and Quality Concepts, Software Quality Assurance (SQA), Software Reviews, Formal Technical Reviews, Formal Approaches to SQA and SSQA, Software Reliability, The ISO 9000 Quality Standards, The SQA Plan.

Prescribed Text Book:

1. Software Engineering – A Practitioner’s Approach, Sixth Edition - Roger S Pressman, TATA McGrawHill: Chapters: 1,2,3,7,8 and 9)

Reference Books:

1. Software Engineering Principles and Practice by Deepak Jain Oxford University Press
2. Sommerville, “Software Engineering”, Eighth Edition, Pearson Education, 2007

Student Activity: Visit any financial organization nearby and prepare requirement analysis report
2. Visit any industrial organization and prepare risk chart.

AG & SG SIDDHARTHA COLLEGE OF ARTS AND SCIENCES - VUYYURU.
An Autonomous college within the jurisdiction of Krishna University A.P, India.
(With Effect from Academic Year 2020-21)

COMPUTER SCIENCE	CSC-502C	2021-'22	B.Sc.(MPCs,MCCs)
-------------------------	-----------------	-----------------	-------------------------

SEMESTER – V

PAPER – VI

Max. Marks 70

Model Paper

SOFTWARE ENGINEERING

NO of Hours: 4

No Of Credits: 3

Pass Marks 28

Section – A

Answer any **FOUR** Questions. Each question carries **FIVE** Marks

4x5=20M

1. Write about Software Layered Technology?
2. Explain about Process Framework?
3. Explain about RAD Model?
4. Explain Validating Requirements
5. Explain about Modularity?
6. Write about Software Reliability?

Section – B

Answer any **FIVE** Questions. Each question carries **TEN** Marks

5X10=50M

7. Explain about CMMI?
8. Explain about Software Myths?
9. Explain about Incremental Model?
10. Explain about Spiral Model
11. Explain about Requirements Engineering Tasks?
12. Write about design concepts in design engineering?
13. Explain about Quality and Quality Concepts?
14. Write about SSQA?

AG & SG SIDDHARTHA COLLEGE OF ARTS AND SCIENCES - VUYYURU.
An Autonomous college within the jurisdiction of Krishna University A.P, India.
(With Effect from Academic Year 2020-21)

COMPUTER SCIENCE	CSC-502C	2021-'22	B.Sc.(MPCs,MCCs)
------------------	----------	----------	------------------

SEMESTER – V PAPER – VI Max. Marks 70 Pass Marks 28

Guidelines for paper setting '**SOFTWARE ENGINEERING**'

Unit wise weightage of Marks

	Section-A (Short answer questions)	Section-B (essay questions)
Unit-1	2	2
Unit-2	1	2
Unit-3	1	2
Unit-4	1	1
Unit-5	1	1

- Each Short answer question carries 5 marks in Section –A
- Each Essay question carries 10 marks in Section –B
- The Question papers setters are requested to cover all the topics in the syllabus stipulated as per the weightage given by us

AG & SG SIDDHARTHA COLLEGE OF ARTS AND SCIENCES - VUYYURU.
An Autonomous college within the jurisdiction of Krishna University A.P, India.
(With Effect from Academic Year 2020-21)

COMPUTER SCIENCE	CSC-502C	2021-'22	B.Sc.(MPCS,MCCs)
-------------------------	-----------------	-----------------	-------------------------

SEMESTER – V

PAPER – VI

Max. Marks 50

Lab List

SOFTWARE ENGINEERING

Pass Marks 25

No. of Hours per week: 2

External: 25

Internal: 25

Credits: 2

A. ATM

1. Objective of an ATM System. 2. Use-case Diagram of an ATM System 3. Class Diagram of an ATM System 4. Sequence Diagram of an ATM System 5. Activity Diagram of an ATM System 6. State Diagram of an ATM System 7. Deployment Diagram of an ATM System

B. Library management System

1. Objective of Library management System. 2. Use-case Diagram of Library management 3. Class Diagram of Library management System 4. Sequence Diagram of Library management 5. Activity Diagram of Library management System 6. State Diagram of Library management 7. Deployment Diagram of Library management System

C. Barcode Reader

1. Objective of Barcode Reader 2. Use-case Diagram of Barcode Reader 3. Class Diagram of Barcode Reader 4. Sequence Diagram of Barcode Reader 5. Activity Diagram of Barcode Reader 6. State Diagram of Barcode Reader 7. Deployment Diagram of Barcode Reader

D. Safe Home System

1. Objective of Safe Home System. 2. Use-case Diagram of Safe Home System 3. Class Diagram of Safe Home System 4. Sequence Diagram of Safe Home System 5. Activity Diagram of Safe Home System 6. State Diagram of Safe Home System 7. Deployment Diagram of Safe Home System

E. Online Book Store System

1. Objective of Online Book Store System 2. Use-case Diagram of Online Book Store System 3. Class Diagram of Online Book Store System 4. Sequence Diagram of Online Book Store 5. Activity Diagram of Online Book Store System 6. State Diagram of Online Book Store System 7. Deployment Diagram of Online Book Store System

AG & SG SIDDHARTHA COLLEGE OF ARTS AND SCIENCES - VUYYURU.

An Autonomous college within the jurisdiction of Krishna University A.P, India.

(With Effect from Academic Year 2020-21)

COMPUTER SCIENCE	CCSC-505C	2021-22	B. Com (CA)
-------------------------	------------------	----------------	--------------------

SEMESTER – V

PAPER – V

Max. Marks 70

Pass Marks 28

Syllabus

OBJECT ORIENTED PROGRAMMING USING JAVA

Total Hrs: 60

NO. Of. Hours: 5

Credits: 3

UNIT-I

10Hrs

Fundamentals of Object – Oriented Programming: Introduction, Object Oriented paradigm, Basic Concepts of OOP, Benefits of OOP, Applications of OOP, Java features:

UNIT-II

14Hrs

Overview of Java Language: Introduction, Simple Java program structure, Java tokens, Java Statements, Implementing a Java Program, Java Virtual Machine, Command line arguments. **Constants, Variables & Data Types:** Introduction, Constants, Variables, Data Types, Declaration of Variables, Giving Value to Variables, Scope of variables, Type casting, Getting Value of Variables, **Operators.**

UNIT-III

12Hrs

Decision Making & Branching: Introduction, Decision making with if statement, Simple if statement, if-Else statement, Nesting of if-else statements, the else if ladder, the switch statement, the conditional operator. **Looping:** Introduction, while statement, do-while statement, for statement, Jumps in loops.

UNIT-IV

12 Hrs

Classes, Objects & Methods: Introduction, defining a class, adding variables, adding methods, creating objects, Accessing class members, Constructors, Method overloading, Method Overriding, Static members, Nesting of methods;

UNIT-V

12Hrs

Inheritance: Extending a Class, Overriding Methods, Final Variables and Methods, Final Classes, Abstract Methods and Classes; **Arrays, Strings And Vectors:** Arrays, One-dimensional arrays, Creating an array, Two – dimensional arrays, Strings, Vectors, Wrapper classes; **Interfaces: Multiple Inheritance:** Introduction, Defining interfaces, Extending interfaces, Implementing interfaces, Assessing interface variables;

Prescribed Text Book:

1. E. Balaguruswamy, Programming with JAVA, A primer, 3e, TATA McGraw-Hill Company.

Reference Books

1. Programming In Java By Sachin Malhotra And Saurabh Choudhary From Oxford University Press
2. Object Oriented Programming Through Java by P. Radha Krishna, Universities Press
3. John R. Hubbard, Programming with Java, Second Edition, Schaum's outline Series,
4. Deitel&Deitel. Java TM: How to Program, PHI (2007)
5. Java Programming: From Problem Analysis to Program Design- D.S Mallik

AG & SG SIDDHARTHA COLLEGE OF ARTS AND SCIENCES - VUYYURU.

An Autonomous college with in the jurisdiction of Krishna University A.P, India.

(With Effect from Academic Year2020-21)

COMPUTER SCIENCE	CCSC-505C	2021-22	B. Com (CA)
-------------------------	------------------	----------------	--------------------

SEMESTER – V PAPER – V

Max. Marks 70

Pass Marks 28

Syllabus: OBJECT ORIENTED PROGRAMMING USING JAVA

Total Hrs: 60

NO. Of. Hours: 4

Credits: 3

Section- A

Answer FOUR Questions. Each Question carries FIVE Marks.

4*5=20M

1. What are the Applications of OOP?
2. What is a variable? Explain its rules?
3. Explain different data types in java?
4. Write about switch statement?
5. Explain about Constructors?
6. Differences between arrays and vectors?

Section- B

Answer FIVE the Questions. Each Question carries TEN Marks

5*10=50M

7. Explain the Concepts of Object Oriented Programming?
8. Explain java Features?
9. Explain the structure of java program?
10. Explain different types of Operators in Java with Examples?
11. Explain about Decision Making Statements with examples?
12. Explain Looping statements with example?
13. Explain Method overloading with an example program?
14. Explain about inheritance?

AG & SG SIDDHARTHA COLLEGE OF ARTS AND SCIENCES - VUYYURU.

An Autonomous college with in the jurisdiction of Krishna University A.P, India.

(With Effect from Academic Year2020-21)

COMPUTER SCIENCE	CCSC-505C	2021-22	B. Com (CA)
-------------------------	------------------	----------------	--------------------

SEMESTER – V PAPER – V

Max. Marks 70

Pass Marks 28

Syllabus

OBJECT ORIENTED PROGRAMMING USING JAVA

Total Hrs: 60

NO. Of. Hours: 4

Credits: 3

Unit wise weightage of Marks

	Section-A (Short answer questions)	Section-B (essay questions)
Unit-1	1	2
Unit-2	2	2
Unit-3	1	2
Unit-4	1	1
Unit-5	1	1

- Each Short answer question carries 5 marks in Section –A
- Each Essay question carries 10 marks in Section –B
- The Question papers setters are requested to cover all the topics in the syllabus stipulated as per the weightage given by us

AG & SG SIDDHARTHA COLLEGE OF ARTS AND SCIENCES - VUYYURU.
An Autonomous college with in the jurisdiction of Krishna University A.P, India.
(With Effect from Academic Year2020-21)

COMPUTER SCIENCE	CCSC-505C	2021-22	B. Com (CA)
-------------------------	------------------	----------------	--------------------

SEMESTER – V

PAPER – V

Lab List: OBJECT ORIENTED PROGRAMMING USING JAVA Pass Marks 25

No. of Hours per week: 2 External: 25 Internal: 25 Credits: 2

1. Write a program to perform various String Operations
2. Write a program to print the given number is Armstrong or not?
3. Prompt for the cost and selling price of an article and display the profit (or) loss
4. Write a program to print the numbers given by command line arguments
5. Write a program on class and object in java
6. Illustrate the method overriding in JAVA
7. Write a program to find the Simple Interest using Multilevel Inheritance
8. Write a program to display matrix multiplication.
9. Write a program on interface in java
10. Write a program on inheritance

AG & SG SIDDHARTHA COLLEGE OF ARTS AND SCIENCES - VUYYURU.
An Autonomous college within the jurisdiction of Krishna University A.P, India.
(With Effect from Academic Year 2020-21)

COMPUTER SCIENCE	CCSC 506C	2021-'22	B.Com.(C.A.)
-------------------------	------------------	-----------------	---------------------

SEMESTER – V

PAPER – VI

Max. Marks 70

Syllabus :

DATA BASE MANAGEMENT SYSTEMS

NO Of Hours: 5

No Of Credits: 3

Pass Marks 28

Course Objective: Design & develop database for large volumes & varieties of data with optimized data processing techniques.

Unit – 1: Database Systems Introduction

12Hrs

Database Systems: Introducing the database and DBMS, Why the database is important, *Historical Roots:* Files and File Systems, Problems with File System, Data Management, Database Systems. *Data Models:* The importance of Data models, Data Model Basic Building Blocks, The evaluation of Data Models.

Unit - II: Relational Database & Data Modelling

12 Hrs

The Relational Database Model: A logical view of Data, Keys, Integrity Rules, Relational Set Operators, Indexes, Codd's relational database rules. *Entity Relationship Model:* The ER Model
Advanced Data Modelling: The Extended Entity Relationship Model, Entity clustering.

Unit-III: Normalization and Database Design

14 Hrs

Normalization of database tables: Database Tables and Normalization, The need for Normalization, The Normalization Process, High level Normal Forms, Normalization and database design, de normalization.

Unit-IV: Structured Query Language

12 Hrs

Introduction to SQL: Data Definition Commands, Data Manipulation Commands, Select queries, Advanced Data Definition Commands, Advanced Select queries, Virtual Tables, SQL Join Operators,

Unit-V: Procedural SQL

10 Hrs

Introduction to PL/SQL : Triggers, Stored Procedures, PL/SQL Stored Functions

Prescribed Text Book:

- 1. Peter Rob, Carlos Coronel, Database Systems Design, Implementation and Management, Seventh Edition, Thomson (2007).**

Reference Books:

- 2Elimasri / Navathe, Fundamentals of Database Systems, Fifth Edition, Pearson Addison Wesley
3. C.J.Date, A.Kannan, S.Swamynathan, An Introduction to Database Systems, Eight edition, Pearson Education (2006).

Student Activity:

1. Create your college database for placement purpose.
2. Create faculty database of your college with their academic performance scores

AG & SG SIDDHARTHA COLLEGE OF ARTS AND SCIENCES - VUYYURU.
An Autonomous college within the jurisdiction of Krishna University A.P, India.
(With Effect from Academic Year 2020-21)

COMPUTER SCIENCE	CCSC 506C	2021-'22	B.Com.(C.A.)
-------------------------	------------------	-----------------	---------------------

SEMESTER – V

PAPER – VI

Max. Marks 70

Model Paper

DATA BASE MANAGEMENT SYSTEMS

NO Of Hours: 5

No Of Credits: 3

Pass Marks 28

Section-A

Answer any **FOUR** Questions. Each question carries **FIVE** Marks

4x5=20M

1. Explain the Components of Database System?
2. Explain Entity Relationship Model?
3. Write about Relational Set Operators?
4. Describe BCNF?
5. Write about Special Functions?
6. Explain Stored Procedures?

Section-B

Answer any **FIVE** Questions. Each question carries **TEN** Marks

5X10=50M

7. What is File? Explain the problems with File system?
8. Explain any three different Data Models?
9. Explain E.F. CODDs' rules?
10. Explain Extended Entity Relationship Model?
11. Explain the concept of Normal Forms?
12. Explain different join operators?
13. Explain DDL and DML commands?
14. Explain about triggers?

AG & SG SIDDHARTHA COLLEGE OF ARTS AND SCIENCES - VUYYURU.
An Autonomous college within the jurisdiction of Krishna University A.P, India.
(With Effect from Academic Year 2020-21)

COMPUTER SCIENCE	CCSC 506C	2021-'22	B.Com.(C.A.)
------------------	-----------	----------	--------------

SEMESTER – V PAPER – VI Max. Marks 70 Pass Marks 28

Guidelines for paper setting '**DATA BASE MANAGEMENT SYSTEMS**'

Unit wise weightage of Marks

	Section-A (Short answer questions)	Section-B (essay questions)
Unit-1	2	2
Unit-2	1	2
Unit-3	1	1
Unit-4	1	2
Unit-5	1	1

- Each Short answer question carries 5 marks in Section –A
- Each Essay question carries 10 marks in Section –B
- The Question papers setters are requested to cover all the topics in the syllabus stipulated as per the weightage given by us

AG & SG SIDDHARTHA COLLEGE OF ARTS AND SCIENCES - VUYYURU.

An Autonomous college within the jurisdiction of Krishna University A.P, India.

(With Effect from Academic Year 2020-21)

COMPUTER SCIENCE	CCSC-506P	2021-'22	B. COM(CA)
-------------------------	------------------	-----------------	-------------------

SEMESTER – V

PAPER – VI

Max. Marks 50

Lab List DATA BASE MANAGEMENT SYSTEMS

Pass Marks 25

No. of Hours per week: 2

External: 25

Internal: 25

Credits: 2

1. Creation of college database and establish relationships between tables
2. Explain various data type in Oracle.
3. Show the structure of the Emp table.
4. Show the structure of the DEPT table.
5. Explain the syntax of SELECT statement.
6. Create a query to display the name, job, hiredate and employee number from emp table.
7. Create a query to display unique jobs from the emp table.
8. Create a query to display the empno as EMP#, ename as EMPLOYEE and Hire_date from emp.
9. Create a query to display all the data from the EMP table. Separate each column by a comma and name the column THE_OUTPUT.
10. Create a query to display the name and salary of employees earning more than 2850.
11. Create a query to display the name and salary for all employees whose salary is not in the range of 1500 and 2850.
12. Display the employee name, job and start date of employees hired between February 20, 1981 and May 1, 1981. Order the query in ascending order of start date
13. Display the employee name and department number of all the employees in departments 10 and 30 in alphabetical order by name.
14. List the name and salary of employees who earn more than 1500 & are in department 10 or 30.
15. Display the name, salary and commissions and sort data in descending order of salary and commission.
16. Display the name and job title of all employees who do not have a manager.
17. Display the name, job and salary for all employees whose job is Clerk or Analyst and their salary is not equal to 1000, 3000 or 5000.
18. Display the names of all employees where the third letter of their name is an 'A'.
19. Display the names of all employees who have two 'L's in their name and are in department 30 or their manager is 7782.
20. Display the name, salary and commission for all employees whose commission amount is greater than their salary increased by 10%.
21. Explain all the character functions.
22. Explain all the number functions.
23. Explain all the Date functions.

Create Student database using the following tables.

STUDENT: Sno : primary key, number Sname : NOT NULL, varchar2 Address: Varchar2

COURSE: Sno : Foreign key. Course Name : varchar2

Queries:

1. Alter table by adding a column fees in table COURSE.
2. Alter table by modifying the address to VARCHAR2(20)
3. Create a view on which the students who joined in one course only.

PL/SQL.

1. Write A Pl/Sql Program To Swap Two Numbers Without Using Third Variable.
2. Write A Pl/Sql Program To Generate Multiplication Tables For Numbers 2,4 And 6
3. Write A Pl/Sql Program To Display Sum Of Even Numbers And Sum Of Odd Numbers In The Given Range.
4. Write A Pl/Sql Program To Check The Given Number Is Pollinndrome Or Not.
5. Write A Pl/Sql Program To Display Top 10 Rows In Emp Table Based On Their Job And Salary.

Reference Books:

1. Oracle Pl/Sql By Example. Benjamin Rosenzweig, Elena Silvestrova, Pearsoneducation 3rd Edition
2. Sql& Pl/Sql For Oracle 10g, Black Book, Dr.P.S. Deshpande

AG & SG SIDDHARTHA COLLEGE OF ARTS AND SCIENCES - VUYYURU.
An Autonomous college within the jurisdiction of Krishna University A.P, India.
(With Effect from Academic Year 2020-21)

COMPUTER SCIENCE	CCSC-507C	2021-'22	B.Com.(CA)
-------------------------	------------------	-----------------	-------------------

SEMESTER – V

PAPER – VII

Max. Marks 70

Syllabus

WEB TECHNOLOGIES

NO Of Hours: 5

No of Credits: 3

Pass Marks 28

Unit -I Introduction to XHTML:

13Hrs

Introduction to HTML, Basic html, Document body text, Hyperlinks, Lists, Tables, Images, Frames, Forms and XHTML.

Unit- II: CSS:

12Hrs

Cascading Style Sheets: Introduction, Defining your own styles, properties and values in styles, Formatting blocks of information, Layers.

Java Script: java Script, the basics, Variables, String Manipulations, Mathematical functions, Statements, Operators.

Unit –III: Objects in Java Script & Dynamic HTML with Java Script

13Hrs

Objects in Java Script: Data and objects in java script, Regular expressions, Exception Handling, built in objects, Events.

Dynamic HTML with Java Script: Data validation, Rollover buttons, Moving images.

Unit –IV: XML Defining Data for Web Applications

12Hrs

XML: Introduction to XML, Basic XML, document type definition, XML Schema, Document object model, Using XML parser.

Unit -V:JSP:

10Hrs

JSP Lifecycle, Basic Syntax, EL (Expression Language), EL Syntax, Using EL Variables

Prescribed Books:

1. Chris Bates, Web Programming Building Internet Application, Second Edition, Wiley

2. Head First Servlets and JSP 2nd Edition, Bryan Basham, Kathy Sierra

3. Uttam Kumar Roy, Web Technologies from Oxford University Press

AG & SG SIDDHARTHA COLLEGE OF ARTS AND SCIENCES - VUYYURU.
An Autonomous college within the jurisdiction of Krishna University A.P, India.
(With Effect from Academic Year 2018-'19)

COMPUTER SCIENCE	CCSC-507C	2021-'22	B.Sc.(MPCs)
-------------------------	------------------	-----------------	--------------------

SEMESTER – V

PAPER – VII

Max. Marks 70

Model Paper

WEB TECHNOLOGIES

No of Credits: 3

Pass Marks 28

Section-A

Answer **FOUR** Questions. Each Question carries **FIVE** Marks.

5 X 4=20M

1. Write about structure of HTML Document with an example?
2. Explain about lists in HTML?
3. Write about java script statements?
4. Write about Rollover buttons?
5. Describe XML Elements?
6. Write the syntax of EL and EL variables?

Section-B

Answer **FIVE** Questions. Each Question carries **TEN** Marks.

5 X 10=50M

7. Explain about hyper links? Write about how to link another pages
8. What is Form? Explain about forms with examples
9. What is CSS? How to design Cascading style sheet
10. Explain about Mathematical Functions
11. Explain about Regular Expressions
12. Write about Data validations in DHTML
13. Explain about Document Object Model
14. Explain about JSP Lifecycle with neat diagram

AG & SG SIDDHARTHA COLLEGE OF ARTS AND SCIENCES - VUYYURU.
An Autonomous college within the jurisdiction of Krishna University A.P, India.
(With Effect from Academic Year 2020-21)

COMPUTER SCIENCE	CCSC-507C	2021-'22	B.COM(CA)
------------------	-----------	----------	-----------

SEMESTER – V PAPER – VII Max. Marks 70 Pass Marks 28

Guidelines for paper setting 'WEB TECHNOLOGIES'

Unit wise weightage of Marks

	Section-A (Short answer questions)	Section-B (essay questions)
Unit-1	2	2
Unit-2	1	2
Unit-3	1	2
Unit-4	1	1
Unit-5	1	1

- Each Short answer question carries 5 marks in Section –A
- Each Essay question carries 10 marks in Section –B
- The Question papers setters are requested to cover all the topics in the syllabus stipulated as per the weight age given by us

AG & SG SIDDHARTHA COLLEGE OF ARTS AND SCIENCES - VUYYURU.
An Autonomous college within the jurisdiction of Krishna University A.P, India.
(With Effect from Academic Year 2021-22)

COMPUTER SCIENCE	CSC-301C	2021-'22	B.Sc.(MPCs,MCCs)
SEMESTER –III	PAPER – III	Max. Marks 70	

Model Paper: **DATA BASE MANAGEMENT SYSTEMS**
NO of Hours: 4 **No Of Credits: 3** **Pass Marks 28**

Course Objective:

The objective of the course is to introduce the design and development of databases with special emphasis on relational databases.

UNIT I **12Hrs**

Overview of Database Management System: Introduction to data, information, database, database management systems, file-based system, Drawbacks of file-Based System, database approach, Classification of Database Management Systems, advantages of database approach, Various Data Models, Components of Database Management System, three schema architecture of data base, costs and risks of database approach.

UNIT II **12Hrs**

Entity-Relationship Model: Introduction, the building blocks of an entity relationship diagram, classification of entity sets, attribute classification, relationship degree, relationship classification, reducing ER diagram to tables, enhanced entity-relationship model (EER model), generalization and specialization, IS A relationship and attribute inheritance, multiple inheritance, constraints on specialization and generalization, advantages of ER modelling.

UNIT III **12Hrs**

Relational Model: Introduction, CODD Rules, relational data model, concept of key, relational integrity, relational algebra, relational algebra operations, advantages of relational algebra, limitations of relational algebra, relational calculus, tuple relational calculus, domain relational Calculus (DRC), Functional dependencies and normal forms upto 3rd normal form.

UNIT IV **12Hrs**

Structured Query Language: Introduction, History of SQL Standard, Commands in SQL, Data Types in SQL, Data Definition Language, Selection Operation, Projection Operation, Aggregate functions, Data Manipulation Language, Table Modification Commands, Join Operation, Set Operations, View, Sub Query.

UNIT V **12Hrs**

PL/SQL: Introduction, Shortcomings of SQL, Structure of PL/SQL, PL/SQL Language Elements, Data Types, Operators Precedence, Control Structure, Steps to Create a PL/SQL, Program, Iterative Control, Procedure, Function, Database Triggers, Types of Triggers.

BOOKS:

1. Database System Concepts by Abraham Silberschatz, Henry Korth, and S. Sudarshan, McGrawhill
2. Database Management Systems by Raghu Ramakrishnan, McGrawhill
3. Principles of Database Systems by J. D. Ullman
4. Fundamentals of Database Systems by R. Elmasri and S. Navathe
5. SQL: The Ultimate Beginners Guide by Steve Tale.

RECOMMENDED CO-CURRICULAR ACTIVITIES:

(Co-curricular activities shall not promote copying from textbook or from others work and shall encourage self/independent and group learning)

A. Measurable

1. Assignments (in writing and doing forms on the aspects of syllabus content and outside the syllabus content. Shall be individual and challenging)
2. Student seminars (on topics of the syllabus and related aspects (individual activity))
3. Quiz (on topics where the content can be compiled by smaller aspects and data (Individuals or groups as teams))

4. Study projects (by very small groups of students on selected local real-time problems pertaining to syllabus or related areas. The individual participation and contribution of students shall be ensured (team activity)

B. General

1. Group Discussion
2. Try to solve MCQ's available online.
3. Others

RECOMMENDED CONTINUOUS ASSESSMENT METHODS:

Some of the following suggested assessment methodologies could be adopted;

1. The oral and written examinations (Scheduled and surprise tests),
2. Closed-book and open-book tests,
3. Practical assignments and laboratory reports,
4. Observation of practical skills,
5. Individual and group project reports like Create your college database for placement purpose.
6. Efficient delivery using seminar presentations,
7. Viva voce interviews.
8. Computerized adaptive testing, literature surveys and evaluations,
9. Peers and self-assessment, outputs form individual and collaborative work

AG & SG SIDDHARTHA COLLEGE OF ARTS AND SCIENCES - VUYYURU.
An Autonomous college within the jurisdiction of Krishna University A.P, India.
(With Effect from Academic Year 2021-22)

COMPUTER SCIENCE	CSC-301C	2021-'22	B.Sc.(MPCs,MCCs)
-------------------------	-----------------	-----------------	-------------------------

SEMESTER – III

PAPER – III

Max. Marks 70

Model Paper : : DATA BASE MANAGEMENT SYSTEMS

NO of Hours: 4

No Of Credits: 3

Pass Marks 28

Section-A

Answer any FOUR Questions. Each question carries FIVE Marks

4x5=20M

1. Explain the Components of Database System?
2. Explain about advantages of database approach?
3. Explain building blocks of an entity relationship diagram?
4. Describe BCNF?
5. Write about Special Functions?
6. Explain Stored Procedures?

Section-B

Answer any FIVE Questions. Each question carries TEN Marks

5X10=50M

7. What is File? Explain the problems with File system
8. Explain the Degree of Data Abstraction.
9. Explain E.F.CODDs' rules.
10. Explain Extended Entity Relationship Model.
11. Explain the concept of Normal Forms.
12. Explain about SDLC.
13. Explain DDL and DML commands.
14. Explain about triggers.

AG & SG SIDDHARTHA COLLEGE OF ARTS AND SCIENCES - VUYYURU.

**An Autonomous college within the jurisdiction of Krishna University A.P, India.
(With Effect from Academic Year 2021-22)**

COMPUTER SCIENCE	CSC-301C	2021-'22	B.Sc.(MPCs,MCCs)
------------------	----------	----------	------------------

SEMESTER – III PAPER –III Max. Marks 70 Pass Marks 28

Guidelines for paper setting '**DATA BASE MANAGEMENT SYSTEMS**'

Unit wise weight age of Marks

	Section-A (Short answer questions)	Section-B (essay questions)
Unit-1	2	2
Unit-2	1	2
Unit-3	1	2
Unit-4	1	1
Unit-5	1	1

- Each Short answer question carries 5 marks in Section –A
- Each Essay question carries 10 marks in Section –B
- The Question papers setters are requested to cover all the topics in the syllabus stipulated as per the weightage given by us

AG & SG SIDDHARTHA COLLEGE OF ARTS AND SCIENCES - VUYYURU.

An Autonomous college within the jurisdiction of Krishna University A.P, India.

(With Effect from Academic Year 2021-22)

COMPUTER SCIENCE	CSC-301P	2021-'22	B.Sc.(MPCS,MCCs)
SEMESTER – III		PAPER – III	Max. Marks 50

Lab List DATA BASE MANAGEMENT SYSTEMS

Pass Marks 25

No. of Hours per week: 2

External: 25

Internal: 25

Credits: 2

1. Draw ER diagram for hospital administration
2. Creation of college database and establish relationships between tables
3. Relational database schema of a company is given in the following figure.
Relational Database Schema - COMPANY
Questions to be performed on above schema
1. Create above tables with relevant *Primary Key, Foreign Key and other constraints*
2. Populate the tables with data
3. Display all the details of all employees working in the company.
4. Display *ssn, lname, fname, address* of employees who work in department no 7.
5. Retrieve the *Birthdate and Address* of the employee whose name is 'Franklin T. Wong'
6. Retrieve the name and salary of every employee
7. Retrieve all distinct salary values
8. Retrieve all employee names whose address is in 'Bellaire'
9. Retrieve all employees who were born during the 1950s
10. Retrieve all employees in department 5 whose salary is between 50,000 and 60,000(inclusive)
11. Retrieve the names of all employees who do not have supervisors
12. Retrieve SSN and department name for all employees
13. Retrieve the name and address of all employees who work for the 'Research' department
14. For every project located in 'Stafford', list the project number, the controlling department number, and the department manager's last name, address, and birth date.
15. For each employee, retrieve the employee's name, and the name of his or her immediate supervisor.
16. Retrieve all combinations of Employee Name and Department Name
17. Make a list of all project numbers for projects that involve an employee whose last name is 'Narayan' either as a worker or as a manager of the department that controls the project.
18. Increase the salary of all employees working on the 'ProductX' project by 15%. Retrieve employee name and increased salary of these employees.

19. Retrieve a list of employees and the project name each works in, ordered by the employee's department, and within each department ordered alphabetically by employee first name.
20. Select the names of employees whose salary does not match with salary of any employee in department 10.
21. Retrieve the employee numbers of all employees who work on project located in Bellaire, Houston, or Stafford.
22. Find the sum of the salaries of all employees, the maximum salary, the minimum salary, and the average salary. Display with proper headings.
23. Find the sum of the salaries and number of employees of all employees of the 'Marketing' department, as well as the maximum salary, the minimum salary, and the average salary in this department.
24. Select the names of employees whose salary is greater than the average salary of all employees in department 10.
25. Delete all dependents of employee whose *ssn is '123456789'*.
26. Perform a query using alter command to drop/add field and a constraint in Employee table.

AG & SG SIDDHARTHA COLLEGE OF ARTS AND SCIENCES - VUYYURU.
An Autonomous college within the jurisdiction of Krishna University A.P, India.
(With Effect from Academic Year 2021-22)

COMPUTER SCIENCE	CCSC-301C	2021-'22	B.com(CA)
-------------------------	------------------	-----------------	------------------

SEMESTER – III

PAPER – III

Max. Marks 70

Syllabus: Programming in C

NO of Hours: 4

No Of Credits: 3

Pass Marks 28

UNIT-I: General Fundamentals& Programming Languages

10Hrs

General Fundamentals: Introduction to computers: Block diagram of a computer, characteristics and limitations of computers, applications of computers, types of computers, computer generations.

Introduction to Algorithms and Programming Languages: Algorithm – Key features of Algorithms, Flow Charts, **Programming Languages** – Generations of Programming Languages – Structured Programming Language- Design and Implementation of Correct, Efficient and Maintainable Programs.

UNIT- II: Introduction To C & Decision Making control Statements

12Hrs

Introduction to C: Introduction – Structure of C Program – Writing the first C Program – File used in C Program – Compiling and Executing C Programs – Using Comment , Keywords – Identifiers – Basic Data Types in C – Variables – Constants – I/O Statements in C-Operators in C- Programming Examples.

Decision Control and Looping Statements: Introduction to Decision Control Statements– Conditional Branching Statements – Iterative Statements – Nested Loops – Break and Continue Statement – Goto Statement.

UNIT III: Arrays

10 Hrs

Arrays: Introduction – Declaration of Arrays – Accessing elements of the Array – Storing Values in Array– Operations on Arrays – one dimensional, two dimensional and multi dimensional arrays, character handling and strings.

UNIT-IV:Functions & Structures

13Hrs

Functions: Introduction – using functions – Function declaration/ prototype – Function definition – function call – return statement – Passing parameters – Scope of variables – Storage Classes – Recursive functions.

Structure, Union, and Enumerated Data Types: Introduction – Nested Structures – Arrays of Structures – Structures and Functions– Union – Arrays of Unions Variables – Unions inside Structures – Enumerated DataTypes.

UNIT-V:Pointes&Files

15Hrs

Pointers: Understanding Computer Memory – Introduction to Pointers – declaring Pointer Variables – Pointer Expressions and Pointer Arithmetic – Null Pointers -- Memory Allocation in C Programs – Memory Usage – Dynamic Memory Allocation – Drawbacks of Pointers

Files: Introduction to Files – Using Files in C – Reading Data from Files – Writing Data to Files – Detecting the End-of-file – Error Handling during File Operations – Accepting Command Line Arguments.

BOOKS

1. E Balagurusamy – Programming in ANSIC – Tata McGraw-Hillpublications.
2. Brain W Kernighan and Dennis M Ritchie - The ‘C’ Programming language” - Pearsonpublications.
3. Ashok N Kamthane: Programming with ANSI and Turbo C, Pearson Edition Publications.
4. YashavantKanetkar - Let Us ‘C’ – BPBPublications.

AG & SG SIDDHARTHA COLLEGE OF ARTS AND SCIENCES - VUYYURU.

An Autonomous college within the jurisdiction of Krishna University A.P, India.

(With Effect from Academic Year 2020-'21)

COMPUTER SCIENCE	CCSC-301C	2021-'22	B.COM(CA)
-------------------------	------------------	-----------------	------------------

SEMESTER – III PAPER – III Max. Marks 70

Pass Marks 28

Title :Programming in 'C'

NO. Of. Hours: 4Credits:3

Section- A

Answer FOUR Questions. Each Question carries FOUR Marks.

4*5=20M

1. Explain different types of programming languages?
2. Explain about Data types in C?
3. Write about Break and Continue Statement?
4. Explain one dimensional array with example?
5. Explain Storage Classes in C?
6. Explain dynamic memory allocation?

Section- B

Answer FIVE the Questions. Each Question carries EIGHT Marks

5*10=50M

7. Draw and Explain Block Diagram of Computer?
8. Explain about Algorithm and Flowchart with Examples?
9. Explain decision making Looping statements with examples?
10. Explain Structure of C Program with Example?
11. Write about two dimension arrays? Give an example program?
12. Write Passing Parameters Techniques in Functions?
13. Difference between structures and unions?
14. What is File? Explain different File Modes?

AG & SG SIDDHARTHA COLLEGE OF ARTS AND SCIENCES - VUYYURU.

An Autonomous college within the jurisdiction of Krishna University A.P, India.

(With Effect from Academic Year 2021-'22)

COMPUTER SCIENCE	CSC-301C	2021-'22	B.com(CA)
------------------	----------	----------	-----------

SEMESTER – III

PAPER –III

Max. Marks 70

Guidelines for paper setting ‘Programming in ‘C’

<u>Unit wise weight age of Marks</u>	Section-A (Short answer questions)	Section-B (essay questions)
Unit-I	2	2
Unit-II	1	2
Unit-III	1	2
Unit-IV	1	1
Unit -V	1	1

- Each Short answer question carries 5 marks in Section –A
- Each Essay question carries 10 marks in Section –B
- The Question papers setters are requested to cover all the topics in the syllabus stipulated as per the weight age given by us

AG & SG SIDDHARTHA COLLEGE OF ARTS AND SCIENCES - VUYYURU.

An Autonomous college within the jurisdiction of Krishna University A.P, India.

(With Effect from Academic Year 2021-22)

COMPUTER SCIENCE	CCSC-301P	2021-'22	B.Com.(CA)
-------------------------	------------------	-----------------	-------------------

SEMESTER – III

PAPER – III

Max. Marks 50

Lab List Programming in 'C'

Pass Marks 20

No. of Hours per week: 2

External: 25

Internal: 25

Credits: 2

1. Write C programs for
 - a. Fibonacci Series
 - b. Prime number
 - c. Palindrome number
 - d. Armstrong number.
2. Write a 'C' program for multiplication of two matrices
3. Write a 'C' program to implement string functions
4. Write a 'C' program to swap numbers
5. Write a 'C' program to calculate factorial using recursion
6. Write a 'C' program to perform addition of two complex numbers using constructor
7. Write a program to find the largest of two given numbers in two different classes using friend function
8. Program to add two matrices using dynamic constructor
9. Implement a class string containing the following functions:
 - a. Overload + operator to carry out the concatenation of strings.
 - b. Overload == operator to carry out the comparison of strings.
10. Program to implement inheritance.

AG & SG SIDDHARTHA COLLEGE OF ARTS AND SCIENCES - VUYYURU.

An Autonomous college within the jurisdiction of Krishna University A.P, India.

(With Effect from Academic Year 2021-22)

Semester I	Course Code	Course Title	Credits	Periods
B.Sc. (MPCS/ MCCS / MSCS)	CSCT11B	Problem Solving In C	4	60

Course Objectives:

This course aims to provide exposure to problem-solving through programming and introduce the concepts of the C Programming language.

Course Learning Outcomes:

Course Outcome No	Upon successful completion of the course, a student will be able to:	Program Outcome No.
CO1	Understand the evolution & functionality of Digital Computers and develop an algorithm for solving a given problem.	PO1, PO7, PSO1, PSO4
CO2	Understand tokens and control structures in C.	PO1, PO7, PSO1, PSO4
CO3	Understand arrays and strings and implement them.	PO1, PO7, PSO1, PSO4
CO4	Understand the right way of using functions, pointers, structures and unions in C	PO1, PO7, PSO1, PSO4
CO5	Develop and test programs written in C files	PO1, PO7, PSO1, PSO4

UNIT I

12 periods

General Fundamentals: Introduction to computers: Block diagram of a computer, characteristics and limitations of computers, applications of computers, types of computers, computer generations.

Introduction to Algorithms and Programming Languages: Algorithm – Key features of Algorithms, Flow Charts, Programming Languages – Generations of Programming Languages – Structured Programming Language- Design and Implementation of Correct, Efficient and Maintainable Programs.

UNIT II

12 periods

Introduction to C: Introduction – Structure of C Program – Writing the first C Program –File used in C Program – Compiling and Executing C Programs – Using Comments – Keywords – Identifiers – Basic Data Types in C – Variables – Constants – I/O Statements in C- Operators in C- Programming Examples.

Decision Control and Looping Statements: Introduction to Decision Control Statements– Conditional Branching Statements – Iterative Statements – Nested Loops – Break and Continue Statement – goto Statement.

UNIT III

10 periods

Arrays: Introduction – Declaration of Arrays – Accessing elements of the Array – Storing Values in Array– Operations on Arrays – one dimensional, two dimensional and multi-dimensional arrays, character handling and strings.

UNIT IV

14 periods

Functions: Introduction – using functions – Function declaration/ prototype – Function definition – function call – return statement – Passing parameters – Scope of variables – Storage Classes – Recursive functions.

Structure, Union, and Enumerated Data Types: Introduction – Nested Structures – Arrays of Structures – Structures and Functions– Union – Arrays of Unions Variables – Unions inside Structures – Enumerated Data Types.

UNIT V

12 periods

Pointers: Understanding Computer Memory – Introduction to Pointers – declaring Pointer Variables – Pointer Expressions and Pointer Arithmetic – Null Pointers - Passing Arguments to Functions using Pointer – Pointer and Arrays – Memory Allocation in C Programs – Memory Usage – Dynamic Memory Allocation – Drawbacks of Pointers

Files: Introduction to Files – Using Files in C – Reading Data from Files – Writing Data to Files – Detecting the End-of-file – Error Handling during File Operations – Accepting Command Line Arguments.

BOOKS

1. E Balagurusamy – Programming in ANSIC – Tata McGraw-Hill publications.
2. Brain W Kernighan and Dennis M Ritchie - The ‘C’ Programming language” - Pearson publications.
3. Ashok N Kamthane: Programming with ANSI and Turbo C, Pearson Edition Publications.
4. Yashavant Kanetkar - Let Us ‘C’ – BPB Publications.

RECOMMENDED CO-CURRICULAR ACTIVITIES:

(Co-curricular activities shall not promote copying from textbook or from others work and shall encourage self/independent and group learning)

A. Measurable

1. Assignments (in writing and doing forms on the aspects of syllabus content and outside the syllabus content. Shall be individual and challenging)
2. Student seminars (on topics of the syllabus and related aspects (individual activity))
3. Quiz (on topics where the content can be compiled by smaller aspects and data (Individuals or groups as teams))
4. Study projects (by very small groups of students on selected local real-time problems pertaining to syllabus or related areas. The individual participation and contribution of students shall be ensured (team activity)

B. General

1. Group Discussion
2. Try to solve MCQ's available online.
3. Others

RECOMMENDED CONTINUOUS ASSESSMENT METHODS:

Some of the following suggested assessment methodologies could be adopted;

1. The oral and written examinations (Scheduled and surprise tests),
2. Closed-book and open-book tests,
3. Problem-solving exercises,
4. Practical assignments and laboratory reports,
5. Observation of practical skills,
6. Individual and group project reports like “Creating Text Editor in C”.
7. Efficient delivery using seminar presentations,
8. Viva voce interviews.
9. Computerized adaptive testing, literature surveys and evaluations,
10. Peers and self-assessment, outputs form individual and collaborative work

@ @ @ @

AG & SG SIDDHARTHA COLLEGE OF ARTS AND SCIENCES - VUYYURU.

An Autonomous college within the jurisdiction of Krishna University A.P, India.

(With Effect from Academic Year 2021-22)

MODEL Question Paper:

TITLE: Problem solving in C

COURSE CODE: CSCT11B

SECTIONS: B.Sc. (MPCS / MCCS/ MSCS)

SEMESTER: I

TIME: 3 Hrs.

MAX: 75M

SECTION –A

ANSWER ANY FIVE QUESTIONS

5 X 5 =25 M.

1. What is a flowchart? Utilize flowchart symbols and draw a flowchart to find biggest of two numbers. (CO1, L3)
2. Write a short note on block diagram of computers. (CO1, L2)
3. Explain do...while loop with an example program. (CO2 , L2)
4. Develop a C program to find largest number in a given integer list. (CO3 ,L3)
5. Classify data types in C. Write a short note on any two data types. (CO2 , L2)
6. How to declare and initialize 1D arrays. (CO3, L1)
7. Construct a student structure to accept student details and write a C program to calculate grade of a student. (CO4 , L3)
8. Illustrate command line arguments with an example program. (CO5, L2)

SECTION – B

ANSWER ALL THE QUESTIONS

5 X 10 =50 M.

- 9 A) Define Algorithm. Demonstrate Key features of algorithm with examples. (CO1, L2)
(or)
B) List out the characteristics and limitations of computers. (CO1, L1)
- 10 A) Give Classification of Control statements in C. Explain multi-way decision making statements in C with examples. (CO2, L2)
(or)
B) Write a program to check whether the given number is Armstrong or not. (CO2, L3)
- 11 A) Develop a program in C for matrix multiplication. (CO3, L3)
(or)
B) Demonstrate various String handling functions in C with examples. (CO3, L2)
- 12 A) Compare and contrast structures with unions. (CO4, L4)
(or)
B) Explain the types of functions in C. (CO4, L2)
- 13 A) List different file handling functions in C. Explain with examples. (CO5, L2)
(or)
B) Explain call by value and call by reference with example. (CO4, L2)

@ @ @ @

AG & SG SIDDHARTHA COLLEGE OF ARTS AND SCIENCES - VUYYURU.

An Autonomous college within the jurisdiction of Krishna University A.P, India.

(With Effect from Academic Year 2021-22)

BLUE PRINT

TITLE: Problem solving in C

COURSE CODE: CSCT11B

SECTIONS: B.Sc. (MPCS / MCCS / MSCS)

SEMESTER: I

TIME: 3 Hrs.

MAX: 75M

SECTION-A

ANSWER ANY FIVE QUESTIONS

5X5=25M

1. Unit 1
2. Unit 1
3. Unit 2
4. Unit 3
5. Unit 2
6. Unit 3
7. Unit 4
8. Unit 5

SECTION – B

ANSWER ALL THE QUESTIONS

5 X 10 =50 M.

9 A) Unit 1.

(or)

B) Unit 1.

10 A) Unit 2.

(or)

B) Unit 2.

11 A) Unit 3.

(or)

B) Unit 3.

12 A) Unit 4.

(or)

B) Unit 4.

13 A) Unit 5.

(or)

B) Unit 5.

@@@@

AG & SG SIDDHARTHA COLLEGE OF ARTS AND SCIENCES - VUYYURU.
An Autonomous college within the jurisdiction of Krishna University A.P, India.
 (With Effect from Academic Year 2021-22)

Semester I	Course Code	Course Title	Credits	Prds
B.Sc.(MPCS / MCCS/ MSCS)	CSCP11B	Problem Solving in C Lab	1	30

Course Outcome No	Upon successful completion of this course, students should have the knowledge and skills to:	Program Outcome No
CO1	Apply logical skills to analyse a given problem	PO1, PO7, PSO1, PSO4, PSO2
CO2	Design an algorithmic solution for a given problem	PO1, PO7, PSO1, PSO4, PSO2
CO3	Write a maintainable C program according to coding standards for a given algorithm	PO1, PO7, PSO1, PSO4, PSO2
CO4	Debug a given program	PO1, PO7, PSO1, PSO4, PSO2
CO5	Execute the C program	PO1, PO7, PSO1, PSO4, PSO2

**Experiments List
Cycle-I**

Week 1:

Write a C program to check whether the given two numbers are equal, bigger or smaller?

Week 2:

Write a C program to perform arithmetic operations using Switch...case?

Week 3:

- Write a program to find the sum of individual digits of a positive integer.
- Write a program to check whether the given number is Armstrong or not.

Week 4:

Write a program to generate the first N terms of the Fibonacci sequence.

Week 5:

Write a program to find both the largest and smallest number in a list of integer values

Week 6:

- Write a program that uses functions to add two matrices.
- Write a program for multiplication of two n X n matrices.

Week 7:

Write a program to demonstrate reflection of parameters in swapping of two integer values using Call by Value & Call by Address.

Week 8:

Write a program to calculate factorial of given integer value using recursive functions.

Cycle-II

Week 9:

Write a program to search an element in a given list of values.

Week 10:

Write a program to illustrate pointer arithmetic.

Week 11:

Write a program to sort a given list of integers in ascending order.

Week 12:

Write a program to calculate the salaries of all employees using Employee (ID, Name, Designation, Basic Pay, DA, HRA, Gross Salary, Deduction, Net Salary) structure.

- a. DA is 30 % of Basic Pay
- b. HRA is 15% of Basic Pay
- c. Deduction is 10% of (Basic Pay + DA)
- d. Gross Salary = Basic Pay + DA+ HRA
- e. Net Salary = Gross Salary - Deduction

Week 13:

Write a program to perform various string operations.

Week 14:

Write a program to read the data character by character from a file.

Week 15:

Write a program to create Book (ISBN, Title, Author, Price, Pages, Publisher) structure and store book details in a file and perform the following operations

- a. Add book details
- b. Search a book details for a given ISBN and display book details, if available
- c. Update a book details using ISBN
- d. Delete book details for a given ISBN and display list of remaining Books.

@@@@

AG & SG SIDDHARTHA COLLEGE OF ARTS AND SCIENCES - VUYYURU.
An Autonomous college within the jurisdiction of Krishna University A.P, India.
 (With Effect from Academic Year 2021-22)

Semester I	Course Code	Course Title	Credits	Periods
B.Com.(Computer Applications	CABT11A	Information Technology	4	75

INFORMATION TECHNOLOGY

Objective:

It provides to learn computer basics and basic principles of using Windows operation system and be able to access the Internet, data communication, Software, hardware and various new technologies in information technology.

Course Outcomes:

COURSE OUTCOME NO	Upon successful completion of this course, students should have the knowledge and skills to
CO1	Understand fundamental concepts of a computer and its basic components
CO2	Understand basic functioning of an operating system and customizing Windows Desktop
CO3	Analyse type of soft wares and programming languages
CO4	Have knowledge in basic Network and Data Communication Concepts
CO5	Understand the need of data mining and get familiarize with basics of new concepts like KDD, OLAP

UNIT-I: INTRODUCTION:

13Periods

- 1.1 Introduction to computers
- 1.2 Generations of computers
- 1.3 An overview of computer system - Types of computers
- 1.4 Input & Output Devices.
- 1.5 Hardware: Basic components of a computer system- Control unit– ALU- Input/output functions.
- 1.6 Memory – RAM – ROM – EPROM - PROM and Other types of memory.

UNIT-II: OPERATING SYSTEM (OS):

12Periods

- 2.1 Meaning - Definition & Functions.
- 2.2 Types of OS - Booting process
 - 2.2.1 DOS – Commands (internal & external) - Wild card characters
- 2.3 Windows: Using the Start Menu –Control Panel – Using multiple
 - 2.3.1 Windows – Customizing the Desktop – Windows accessories (Preferably latest version of windows or Linux Ubuntu).

Unit-III: SOFTWARE:

15Periods

- 3.1 System software and application software.
 - 3.1.1 Operating system windows OS,
 - 3.1.2 Mobile device operating system and notebook operating systems
- 3.2 Application software Types of personal application software
 - 3.2.1 Spread sheet-data management
 - 3.2.2 Word processing
 - 3.2.3 Desktop publishing
 - 3.2.4 Graphics, CAD, CAM, CIM
- 3.3 Programming Languages
 - 3.3.1 Assembly language
 - 3.3.2 Procedural language, non-procedural language, natural programming language.

3.3.3 Hypertext mark-up language, modelling language, object-oriented programming language.

Unit-IV: DATA COMMUNICATION:

20 Periods

4.1 Telecommunication and Networks Communication media & channel cable media

4.1.1 Broad cast media channels twisted pair

4.1.2 Coaxial cable, fibers optical cable, micro wave, satellite, radio, cellular radio, infrared global positioning system.

4.2 Introduction, Analog and Digital signals, modulation need of modulations, modems.

4.3 Telecommunication System communication processors:

4.3.1 Modem

4.3.2 Multiplexers

4.3.3 Front –end-processor.

4.4 Networks LAN, WAN, VAN, virtual private network (VPN).

4.5 Internet, intranet and Extranets

4.5.1 The evolution of the internet, service provided by the internet, World Wide Web.

Unit-V: NEW TECHNOLOGIES:

10 Periods

5.1 New technologies in Information Technology:

5.1.1 Introduction to hyper media, artificial intelligence and business intelligence, knowledge discovery in database (KDD)

5.2 Data warehouse and data marts. Data mining and OLAP.

Student Activity:

Students have to submit assignments and give seminars on various topics allotted to them.

Total of 5 Hrs is allotted for student seminars. Student activity also includes gathering of information related to latest technologies in computers.

Library Activity:

Students will visit library in their allotted time and will refer various text books to gather information for their assignments.

TEXT/ REFERENCE BOOKS:

1. B.E.V.L.Naidu, V.V.. Devi Prasad Konti, Ganti Naga Srikanth, Himalaya publishing House.
2. Introduction to Computers: Peter Norton, McGraw Hill

@@@

AG & SG SIDDHARTHA COLLEGE OF ARTS AND SCIENCES - VUYYURU.

An Autonomous college within the jurisdiction of Krishna University A.P, India.

(With Effect from Academic Year 2021-22)

MODEL Question Paper:

PAPER TITLE: Problem solving in C COURSE CODE: CABT11A

CLASS: B.Com (Computer Applications)

SEMESTER: I

TIME: 3 Hrs.

MAX: 75M

SECTION – A

Answer any five of the following

5X5 =25M

1. Illustrate the characteristics of RAM and ROM. (CO1, L2)
2. Define Operating system. What are different types of OS? (CO2, L1)
3. Demonstrate application software and system software. (CO3, L2)
4. What are the different types of networks? (CO4, L1)
5. Explain the steps involved in the process of KDD. (CO5, L2)
6. Explain about input devices. (CO1, L2)
7. What are analog and digital signals? (CO4, L1)
8. Explain Data warehouse. (CO5, L2)

SECTION –B

Answer the following

5x10=50M

9. a) Explain the block diagram of computer. (CO1, L2)

OR

- b) Explain the generations of computers. (CO1, L2)

10. a) What are the functions of operating system? (CO2, L1)

OR

- b) What are DOS Internal and External commands? (CO2, L1)

11. a) Explain the characteristics of various types of programming languages. Give examples. (CO3, L2)

OR

- b) Summarize the concepts on CAD, CAM and CIM. (CO3, L2)

12. a) Define the various types of Communication media and channels. (CO4, L1)

OR

- b) What are the Advantages and Disadvantages of Internet? (CO4, L1)

13. a) Demonstrate On-Line Analytical process (OLAP). (CO5, L2)

OR

b) Explain about Artificial Intelligence and Business Intelligence. (CO5, L2)
@@@

AG & SG SIDDHARTHA COLLEGE OF ARTS AND SCIENCES - VUYYURU.
An Autonomous college within the jurisdiction of Krishna University A.P, India.
(With Effect from Academic Year 2021-22)

Semester I	Course Code	Course Title	Credits	Periods
B.Com. (E-Commerce)	CSCT11B	E-COMMERCE & WEB DESIGNING	4	60

COURSE OBJECTIVES:

The main objective of the course is to impart conceptual understanding on business transactions on worldwide web and electronic commerce & Electronic Customer Relationship Management and Web designing concepts for Providing quality content on website.

COURSE OUTCOMES:

COURSE OUTCOME NO	Upon successful completion of this course, students should have the knowledge and skills to
CO1	Understand the structure of HTML its basic tags
CO2	Implement various HTML tags for web page development
CO3	Understand about implementing forms and frames in web page designing
CO4	Gain knowledge in E- commerce and its business models
CO5	Differentiate traditional and e – marketing and also gain knowledge in E-CRM and EPS

UNIT I: Introduction to Web Designing

(12Hrs)

- 1.1 Introduction
- 1.2 1.1.1 WWW and its Evaluation
- 1.1.2 Define network and its advantages
- 1.1.3 Types of networks
- 1.1.4 Network Topologies
- 1.2 HTML
- 1.2.1 Define HTML
- 1.2.2 Structure of HTML
- 1.2.3 Basic HTML tags
- 1.2.4 Formatting HTML tags

UNIT II: HTML Tags

(12Hrs)

- 2.1: Lists
- 2.1.1 Ordered List
- 2.1.2 Unordered List
- 2.2 Links
- 2.2.1 Link tag
- 2.2.2 image tag
- 2.2.3 Marquee tag
- 2.3 Tables
- 2.3.1 Table Creation
- 2.3.2 Attributes of Table

UNIT III: Forms and Frames and CSS

(12Hrs)

- 3.1 forms

- 3.1.1 forms creation
- 3.1.2 form tag
- 3.1.3 input fields of form

3.2 Frames

- 3.2.1 Frame Creation
- 3.2.2 Frameset tag
- 3.2.3 frame tag

3.3 Cascading Style Sheets

- 3.3.1 Introduction to CSS
- 3.3.1 Types of CSS
- 3.3.2 in-line Style Sheet
- 3.3.3 internal Style Sheet
- 3.3.4 External Style Sheet

UNIT IV: An Overview on E-Commerce

(10Hrs)

4.1.1 Introduction E-Commerce

- 1. Definition of E- Commerce and its advantages & disadvantages
- 2. Electronic Data Interchange (EDI)
- 3. E-Commerce transactional issues and challenges
- 4.1.4 Difference between Commerce and E-Commerce

4.2 Business Models for Ecommerce

- 1. B2C -Business to consumer.
- 2. B2B – Business to business
- 3. C2B – Consumer to business.
- 4. C2C – Consumer to consumer.

UNIT V: E-Marketing &E – CRM& Electronic Payment Systems

(14Hrs)

5.1 Online Marketing

- 1. Traditional Vs. E-Marketing
- 5.1.2 Online Marketing
- 5.1.3 E-Advertising
- 5.1.4 Internet marketing

5.2 E – CRM

- 5.2.1 Definition of CRM and E-CRM and its Applications
- 5.2.2 E- CRM Architectural components
- 5.2.3 Definition & characteristics of E- SCM
- 5.2.4 Benefits and goals of E – SCM
- 5.2.5 E-Logistics of UPS

5.3 Electronic Payment Systems

- 5.3.1 Types of EPS
- 5.3.2 Traditional payment system and modern payment system
- 5.3.3 Steps for electronic payment
- 5.3.4 Payment security

Text Book:

- 1. Uttam Kumar Roy, Web Technologies, Oxford University Press.
- 2. E-Commerce- A Managerial Perspective- P. T. Joseph, Prentice- Hall of India, New Delhi, 2005.

References:

- 1. Kogent Learning Solutions Inc.(Author), “Black Book HTML 5.0”, dreamtech.
- 2. Daniel Amor, E-Business R(Evolution), Pearson Edude, New Delhi, 2005.

AG & SG SIDDHARTHA COLLEGE OF ARTS AND SCIENCES - VUYYURU.
An Autonomous college within the jurisdiction of Krishna University A.P, India.
(With Effect from Academic Year 2021-22)

<i>Computer Science</i>		2021-22	B.Com (Computers Applications)
-------------------------	--	----------------	---------------------------------------

SEMESTER - I

Credits: 2

WEB DESIGNING LAB (NEW SYLLABUS)

COURSE OBJECTIVES:

The purpose of this course is to introduce to students to the field of creation web pages using HTML language. The students will be able to enhance their analyzing and help to creation for Web Site Design

COURSE OUTCOMES:

COURSE OUTCOME NO	Upon successful completion of this course, students should have the knowledge and skills to
CO1	Implement HTML tags.
CO2	Implementing lists and tables in web pages.
CO3	Implementing frames in web pages.
CO4	Implementing frames in web pages.
CO5	Creation of CSS in a web page.

1. Write a HTML program to print text in bold and italic font.
2. Write a HTML program to print Heading tags.
3. Write a HTML program using Text formatting tags
3. Write a HTML program to implement unordered lists.
4. Write a HTML program to implement order lists.
5. Write a html file which display 3 images at LEFT, RIGHT and CENTER respectively in the browser.
- 6 Create a HTML file which contains hyperlinks.
- 7 Write a HTML program to create a table
8. Write a HTML program to create a table using Row Span and Cols pan
9. Write a HTML program to create a table using cell padding and Row Spacing
10. Write a HTML program to create a simple form
11. Create a Registration form that interacts with the user. Collect login name, password, date of birth, gender, address, qualification.
12. Create a HTML page using frameset tag.
- 13Write a Program to create an inline style sheet.
14. Write a program to create Embedded Style Sheet.
15. Write a program to create an external style sheet to illustrate the “Font” elements.

AG & SG SIDDHARTHA COLLEGE OF ARTS AND SCIENCES - VUYYURU.
An Autonomous college within the jurisdiction of Krishna University A.P, India.
(With Effect from Academic Year 2021-22)

E-Commerce & Web Designing
Model Paper

Class: B.Com (Computer Applications)
Course Code:
Semester: II

Max Marks: 75 M
Time: 3Hours

Section-A

ANSWER ANY FIVE QUESTIONS

5X5M=25M

1. Define Networks and its types? (CO3, L1)
2. Explain Link tags in HTML (CO4, L2)
3. Define frames in HTML (CO5, L1)
4. Explain the E-Commerce (CO1, L2)
5. Compare Traditional marketing and E-Marketing. (CO2, L2)
6. Demonstrate concept of formatting Tags (CO4, L2)
7. Compare Commerce and E-Commerce. (CO1, L2)
8. Explain Benefits and goals of E – SCM. (CO2, L2)

Section-B

ANSWER THE FOLLOWING QUESTIONS

5X10M=50M

9. (A) Define Structure of HTML with examples (CO3, L1)
(OR)
(B) What are different types Network Topologies? (CO3, L1)
10. (A) Classify List Types in HTML. (CO4, L2)
(OR)
(B) Demonstrate the concept of Table creation with apply all Attributes. (CO4, L2)
11. (A) Define forms in html and creation of form with all input types? (CO5, L1)
(OR)
(B) What are different types of CSS with suitable examples? (CO5, L1)
12. (A) Explain EDI. (CO1, L2)
(OR)
(B) Classify Business Models for Ecommerce. (CO1, L2)
13. (A) Illustrate E- CRM Architectural components. (CO2, L2)
(OR)
(B) Explain Electronic Payment Systems. (CO2, L2)

AG & SG SIDDHARTHA COLLEGE OF ARTS AND SCIENCES - VUYYURU.
An Autonomous college within the jurisdiction of Krishna University A.P, India.
(With Effect from Academic Year 2021-22)

Semester I	Course Code	Course Title	Credits	Periods
Life Skill Course	LSC1	BASIC COMPUTER APPLICATIONS	2	30

COURSE OBJECTIVES:

This course aims at providing exposure to students in skill development towards basic office applications.

Course Learning Outcomes:

After successful completion of the course, student will be able to:

1. Demonstrate basic understanding of computer hardware and software.
2. Apply skills and concepts for basic use of a computer.
3. Identify appropriate tool of MS office to prepare basic documents, charts, spreadsheets and presentations.
4. Create personal, academic and business documents using MS office.
5. Create spreadsheets, charts and presentations.
6. Analyze data using charts and spread sheets.

Unit- I Basics of Computers:

8 Hrs

Definition of a Computer - Characteristics of computers, Applications of Computers – Block Diagram of a Digital Computer – I/O Devices, hardware, software human ware, application software, system software, Memories - Primary, Auxiliary and Cache Memory.

MS Windows – Desktop, Recycle bin, My Computer, Documents, Pictures, Music, Videos, Task Bar, Control Panel.

Unit-II: MS-Word:

8Hrs

Features of MS-Word - MS-Word Window Components - Creating, Editing, Formatting and Printing of Documents – Headers and Footers – Insert/Draw Tables, Table Auto format – Page Borders and Shading – Inserting Symbols, Shapes, Word Art, Page Numbers, MailMerge.

Unit-III: MS-Excel:

10Hrs

Overview of Excel features – Creating a new worksheet, Selecting cells, Entering and editing Text, Numbers, Inserting Rows/Columns – Changing column widths and row heights, Formulae, Referencing cells, Changing font sizes and colors, Insertion of Charts, Auto fill, Sort. **MS-PowerPoint:** Features of PowerPoint – Creating a Presentation - Inserting and Deleting Slides in a Presentation – Adding Clip Art/Pictures - Inserting Other Objects, Audio, Video - Resizing and scaling of an Object – Slide Transition – Custom Animation.

(Co-curricular activities shall not promote copying from textbook or from others work and shall encourage self/independent and group learning)

1. Assignments (in writing and doing forms on the aspects of syllabus content and outside
a. the syllabus content. Shall be individual and challenging)
2. Student seminars (on topics of the syllabus and related aspects (individual activity))
3. Quiz, Group Discussion
4. Solving MCQ's available online.

5. Suggested student hands on activities:
 - Create two folders, Rename the folder, create two files each using notepad and paint, move the files from one folder to another folder, delete a file you have created, copy and paste text within notepad.

 - Create a letter head for your college with watermark, your resume, visiting card, brochure for your college activity, organization chart for your college, any advertisement, Prepare your Class time table.

 - Prepare your mark sheet, Prepare your class time table, Prepare a salary bill for an organization, Sort the bill as per the alphabetical order of the names, Get online weather data and analyze it with various charts.

 - Create a PowerPoint presentation for a student seminar.

Reference Books

1. Working in Microsoft Office – Ron Mansfield - TMH.
2. MS Office 2007 in a Nutshell –Sanjay Saxena – Vikas Publishing House.
3. Excel 2020 in easy steps-Michael Price – TMH publications

AG & SG SIDDHARTHA COLLEGE OF ARTS AND SCIENCES - VUYYURU.
An Autonomous college within the jurisdiction of Krishna University A.P, India.
(With Effect from Academic Year 2021-22)

MODEL Question Paper:

PAPER TITLE: BASIC COMPUTER APPLICATIONS

COURSE CODE: LSC1

SEMESTER: I

TIME: 2 Hrs.

MAX: 50M

SECTION – A

(Total: 4x5=20 Marks)

Answer any **four questions**. Each answer carries **5 marks**

- 1.
- 2.
- 3.
- 4.
- 5.
- 6.
- 7.
- 8.

SECTION – B

(Total: 3x10 = 30 Marks)

(Answer any **three questions**. Each answer carries **10 marks**)

- 1.
- 2.
- 3.
- 4.
- 5.

**A.G& S.G.SIDDHARTHA DEGREE COLLEGE OF ARTS &
SCIENCE**

VUYYURU-521165, KRISHNA Dt., A.P.(Autonomous)

Accredited by NAAC with "A" Grade

2021-2022



DEPARTMENT OF COMPUTER SCIENCE

MINUTES OF BOARD OF STUDIES







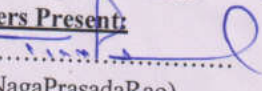

EVEN SEMESTER

07-04-2022

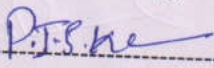
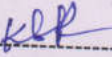
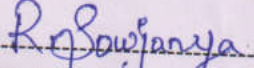
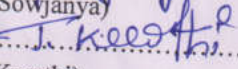
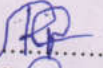
Minutes of the meeting of Board of Studies in Computer Science for Semester II, IV & V of I, II & III years B.Sc. (MPCs, MCCs, MSCs), B.Com. (C.A.), B.Com (e-Commerce) and Life Skill Course and Skill Development Course of AG & SG Siddhartha Degree College of Arts & Science, Vuyyuru, held at 2.30 P.M on 07-04-2022 in the Department of Computer Science.

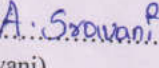
Sri T.NagaPrasadaRao ... Presiding

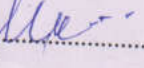
Members Present:

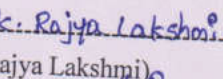
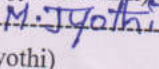
- 1).......... Chairman Head, Department of Computer Science,
(T.NagaPrasadaRao) AG & SG Siddhartha Degree College of Arts & Science.
- 2).......... University Principal, University College of Engineering and Technology,
(Dr. M. Babu Reddy) Nomine KRU, Machilipatnam.
- 3).......... Subject Principal, A.N.R College, Gudivada,
(Dr. P. J. S Kumar) Expert Department of Computer Science
- 4).......... Subject Deputy Head, Department of Computer Science
(Mr. K. Sridhar) Expert PB Siddhartha College of Arts & Science, Vijayawada.
- 5).......... Industrial .Net Developer, Maven Soft System Pvt. Ltd
(R. Sowjanya) Expert Madaapur, Hyderabad.
- 6).......... Member Lecturer in Computer Science, AG & SG Siddhartha
(T. Keerthi) Degree College of Arts & Science, Vuyyuru
- 7).......... Member Lecturer in Computer Science, AG & SG Siddhartha
(K Srikanth) Degree College of Arts & Science, Vuyyuru-521165.
- 8).......... Member Lecturer in Computer Science, AG & SG Siddhartha
(S.Prabhayathi) Degree College of Arts & Science, Vuyyuru-521165
- 9).......... Member Lecturer in Computer Science, AG & SG Siddhartha
(A. Sravani) Degree College of Arts & Science, Vuyyuru-521165
- 10).......... Member Lecturer in Computer Science, AG & SG Siddhartha
(V.N.MalleswaraRao) Degree College of Arts & Science, Vuyyuru-521165
- 11).......... Member Lecturer in Computer Science, AG & SG Siddhartha
(A. Naga Srinivasa Rao) Degree College of Arts & Science, Vuyyuru-521165
- 12).......... Member Lecturer in Computer Science, AG & SG Siddhartha
(V. Munni) Degree College of Arts & Science, Vuyyuru-521165
- 12).......... Member Lecturer in Computer Science, AG & SG Siddhartha
(V. Supriya) Degree College of Arts & Science, Vuyyuru-521165
- 13).......... Member Student in M.Sc. Computer Science, AG& SG Siddhartha
(K. Rajya Lakshmi) Degree College of Arts & Science, Vuyyuru-521165
- 14).......... Member Student in B.Sc. Computer Science, AG& SG Siddhartha
(M. Jyothi) Degree College of Arts & Science, Vuyyuru-521165

Agenda for B.O.S Meeting.

1. To Discuss and approve the Structure and Syllabi, Model Question Paper for Second Semester of B.Sc.(MPCs, MCCs. MSCs) & B.Com (C.A), B.Com(e-commerce-computers) Programs for the student are admitted from the Academic Year 2021-22.
2. To discuss introducing B.Com (e-commerce-computers) and B.Sc.(M.S.Cs) in Second semester for the students admitted in academic year 2021 – 2022
3. To Discuss and approve the Structure and Syllabi, Model Question Paper for Fourth Semester of B.Sc.(MPCs, MCCs.) & B.Com (C.A) Programs for the Academic Year 2021-22.
4. To Discuss and approve the Structure and Syllabi, Model Question Paper for Six Semester of B.Sc.(MPCs, MCCs.) & B.Com (C.A) Programs for the Academic Year 2021-22.
5. To recommend any changes in the syllabi for II, IV, VI Semesters of I, II, III year Degree B.Sc.(MPCs, MCCs, MSCs), B.Com.(C.A.) and B.Com(e-commerce).
6. To recommend the teaching and evaluation methods to be followed under Autonomous status.
7. To recommend the panel of paper setters and examiners to the controller of the examinations of autonomous courses of AG & SG Siddhartha Degree College of Arts & Science College, Vuyyuru.
8. Any other matter

Resolutions.

- 1) It is Resolved and Recommended to adopt the structure and syllabi and Model Question Papers for second semester of B.Sc.(MPCs, MCCs, MSCs) & B.Com (C.A), B.Com(e-Commerce-computers) Programs under CBCS(Choice Based Credit System) Approved by the Academic Council from the Academic Year 2021-22.
- 2) **It is Resolved and Recommended to adopt the structure and syllabi and Model Question Papers for Second semester of B.Sc.(MCCs) & B.Com (e-commerce-computers), Programs under CBCS(Choice Based Credit System) Approved by the Academic Council from the Academic Year 2021-22**
- 3) It is resolved and recommended to introduce new structure for *4th semester of B. Sc. (MPCS, MCCS) and B.Com(CA) programmes* in line with APSCHE guidelines for the students admitted in academic year 2020 – 2021 and onwards
- 4) It is Resolved and Recommended to adopt the structure and syllabi and Model Question Papers for six semester of B.Sc.(MPCs, MCCs) & B.Com (C.A), Programs under CBCS(Choice Based Credit System) Approved by the Academic Council from the Academic Year 2020-21
- 5) **It is Resolved and Recommend any changes in the syllabi for II, IV, VI Semesters of I, II, III year Degree B.Sc.(MPCs, MCCs, MSCs), B.Com.(C.A.) and B.Com(e-commerce).**
 - **It is Resolved and Recommend change Syllabi and Model Question paper as per new regulations in IV Semester of II Year Degree B.Sc. (MPCs, MCCs) and B.Com(CA).**
 - **It is Resolved and recommend NO changes in the syllabi for VI Semester of III Year B.Sc.(MPCs, MCCs) & B.Com.(CA).**
- 6) It is resolved to continue the teaching and evaluation methods to be followed under Autonomous status.
- 7) It is resolved to continue the panel of paper setters and examiners to the controller of the examinations of autonomous courses of AG & SG Siddhartha Degree College of Arts & Science College, Vuyyuru.
- 8) Any other matter

Teaching methods:

Besides the conventional methods of teaching, we use modern technology i.e. Using of LMS and LCD projector to display on power board etc..for better understanding of concepts.

Evaluation of a student is done by the following procedure:

There are two components in the Valuation and Assessment of a student – Internal Assessment (IA) Semester Examinations (SE). **For the Batch of Students Admitted from 2021-22.**

Internal Assessment (IA)

- The maximum mark for IA is 25 and SE is 75 for theory; and for practical marks for IA 10 and 40 Marks for External Exam.
- Each IA written examination is of 1 hour 30 minutes duration for 20 marks. The tests will be conducted centrally. The average of two such IA is calculated for 20 marks.
- Other Innovative Components will be for 5 Marks. The innovative component is for 5 marks, conducted during the class hours by the staff member/ in charge of the subject, in the form of assignments/ quiz/ seminars /PPT/Online- assignments/Open Book/Viva Voce/ Group work/ Mini Project/ Exhibition, etc. The topic and time for submission/ presentation will be announced by the staff member/ in charge of the subject in advance. Each student should explain and defend his/her presentation.
- The semester examination will be of 3 hours with maximum 75 marks.
- There are no passing minimum marks for IA.

Internal Assessment (IA) For the Batch of Students Admitted from 2019-20.

- The maximum mark for IA is 30 and SE is 70 for theory; and for practical marks for IA 10 and 40 Marks for External Exam.
- Each IA written examination is of 1 hour 30 minutes duration for 20 marks. The tests will be conducted centrally. The average of two such IA is calculated for 20 marks.
- Other Innovative Components will be for 5 Marks. The innovative component is for 5 marks, conducted during the class hours by the staff member/ in charge of the subject, in the form of assignments/ quiz/ seminars /PPT/Online- assignments/Open Book/Viva Voce/ Group work/ Mini Project/ Exhibition, etc. The topic and time for submission/ presentation will be announced by the staff member/ in charge of the subject in advance. Each student should explain and defend his/her presentation.
- For attendance 5 Marks are allotted.
- The semester examination will be of 3 hours with maximum 70 marks.
- There are no passing minimum marks for IA.

Semester Examinations (SE)

- A student should register himself/herself to appear for the Semester Examinations by payment of the prescribed fee.
- The Semester Examinations will be in the form of a comprehensive examination covering the entire syllabus in each subject. It will be of 3 hours duration & Foundation course 2 hours irrespective of the number of credits allotted to it.
- If a candidate fails to obtain pass marks even after the due to less mark in the IA examination, the marks of the next examination will be converted to be out of 100.
- Even though the candidate is absent for two IA exams/obtain zero marks the external marks are considered (if he/she gets 40/100) and the result shall be declared as 'PASS'.
- The maximum marks for each Paper shall be 100.

Question paper guide lines for Practical Examinations at the end of Semesters II, IV & VI Two Practical Programs to be conducted out of 15 programs at the end of Semester II, IV & VI Practical Examination time 3Hrs and Maximum Marks 50 Scheme of valuation Semesters – I, III & V B.Sc.& B.Com.(C.A),

Computer Science Practical's - External (Time: 3 hrs.)**Total Marks: 40M**

1. Programs writing (2):	20 marks,
2. Viva voice :	5 marks
3. Execution & Result :	15 marks

Total Marks	:	:	40
-------------	---	---	----

Computer Science Practical's- Internal**Total Marks: 10 M**

1. . Record	:	10 marks
-------------	---	----------

6.) Discussed and recommended for organizing Seminars, Guest lectures, Work-shops to upgrade the knowledge of students, for the approval of the Academic Council.

7) Discussed and empowered the HOD to suggest the panel of the paper setters and examiners to the controller of the examinations.

8). We implemented online certificate courses such as NPTEL, APSSDC - PYTHON, R- Programming, Amazon Web services and JAVA ——— etc. To fill the curriculum gaps from II year Degree on words

9). Suggestions



Chairman

A.G & S.G.SIDDHARTHA DEGREE COLLEGE OF ARTS & SCIENCE

Vuyyuru-521165. NAAC reaccredited at 'A' level

Autonomous -ISO 9001 – 2015 Certified

DEPARTMENT OF COMPUTER SCIENCE

LIST OF THE COURSES REVISED/ INTRODUCED IN II, IV & VI SEMESTERS -2021-22

LIST OF THE COURSES REVISED/ INTRODUCED IN II, IV & VI SEMESTERS -2021-22										
S. NO	Name of the Course	Course Code	SEM No	Type of the Paper	Total Marks	IA TEST	SEE	Teaching Hours	Credits	Offered to (Name of the Programme)
1	Data Structures	CSCT21B	II	Core	100	25	75	4	3	B.Sc (MPCs, MCCs, MSCs)
2	Data Structures Lab	CSCT21B	II	Core Lab	50	10	40	2	1	B.Sc (MPCs, MCCs, MSCs)
3	E-COMMERCE & WEB DESIGNING	CABT21A	II	Core	100	25	75	4	3	B.Com(CA)
4	Web Design Lab	CABT21A	II	Core Lab	50	10	40	2	1	B.Com(CA)
5	Information Technology	CABT21A	II	Core	100	25	75	4	4	B.Com(ecomm er- Computers)
6	Computer Applications	CABT22A	II	Core	100	25	75	4	3	B.Com(ecomm er- Computers)
7	Computer Application Lab	CABT22A	II	Core Lab	50	10	40	2	1	B.Com(ecomm er- Computers)
8	Digital Marketing	SDCCSC02	II	SDC	50	10	40	2	2	B.Sc (MPCs, MCCs, MSCs)
9	Oop's With JAVA	CSCT01	IV	Core	100	30	70	4	3	B.Sc (MPCs, MCCs)
10	Oop's With JAVA Lab	CSCT01	IV	Core Lab	50	10	40	2	1	B.Sc (MPCs, MCCs)
11	Operating System	CSCT41C	IV	Core	100	30	70	4	3	B.Sc (MPCs, MCCs)
12	Operating system Lab	CSCT41C	IV	Core Lab	50	10	40	2	1	B.Sc (MPCs, MCCs)
13	DBMS	CCSE401G	IV	Core	100	30	70	4	3	B.Com(CA)
14	DBMS Lab	CCSC401P	IV	Core Lab	50	10	40	2	1	B.Com(CA)
15	Oop's With JAVA	CCSC402G	IV	Core	100	30	70	4	3	B.Com(CA)
16	Oop's With JAVA Lab	CCSC402P	IV	Core Lab	50	10	40	2	1	B.Com(CA)
17	Web Technology	CSC601GE	VI	Core	100	30	70	4	3	B.Sc (MPCs, MCCs)

18	Web Technology Lab	CSC601GE	VI	Core Lab	50	10	40	2	2	B.Sc (MPCs, MCCs)
19	PHP & My sql, Word Press	CSC602CE	VI	Cluster	100	30	70	4	3	B.Sc (MPCs, MCCs)
20	PHP & My sql Lab	CSC602CE	VI	Cluster Lab	50	10	40	2	2	B.Sc (MPCs, MCCs)
21	Java Script/Ajax	CSC603CE	VI	Cluster	100	30	70	4	3	B.Sc (MPCs, MCCs)
22	Java Script Lab	CSC603CE	VI	Cluster Lab	50	10	40	2	2	B.Sc (MPCs, MCCs)
23	Project	CSC604CE	VI	Cluster	100	30	70	4	4	B.Sc (MPCs, MCCs)
24	Tally	CCSC605CE	VI	Core	100	30	70	4	3	B.Com(CA)
25	Tally Lab	CCSC605P	VI	Core Lab	50	10	40	2	2	B.Com(CA)
26	E-Commerce	CSC606CE	VI	Core	100	30	70	5	5	B.Com(CA)
27	PHP & MY Sql	CCSC606CE	VI	Core	100	30	70	4	3	B.Com(CA)
28	PHP & MY Sql Lab	CCSC606P	VI	Core	50	10	40	2	2	B.Com(CA)
TOTAL(Maximum)					2100	550	1550	85	66	



A.G. & S.G. Siddhartha Degree College of Arts & Science
Vuyyuru-521165, Krishna District, Andhra Pradesh
(An Autonomous institution in the jurisdiction of Krishna University, Machilipatam)
NAAC "A" Grade, ISO 9001:2015 Certified Institution

DEPARTMENT OF COMPUTER SCIENCE

Minutes of the meeting of Board of Studies in Computer Science for UG held on 07-04-2022 in the Department of Computer Science.

Semester	: II	Programme	: MPCs,MCCS,MSCS
Course	: DATA STRUCTURES	Course Code	: 22CS2T3
Course delivery method	: Class room / Blended	Credits	: 4
Credits	: 4	CIA marks	: 25
No. of lecture hours / week	: 4	Semester end exam	: 75
Total no. of lecture hours	: 60	Total marks	: 100
Year of Introduction	: 2021-22	Year of Revision	: 2021-22
% of revision:	: 100%		

Course content suggested by APSICHE	Additions	Deletions
Unit - 1 Introduction to Data Structures , Arrays	Principles of Programming and Analysis of Algorithms	-----
Unit - 2 Linked Lists: Stacks: Queues:	**STACKS, QUEUES Topics moved to Unit-3	-----
Unit - 3 Binary Trees:	Binary Trees Topic moved to unit- 4	-----
Unit-4 Graphs:	Graphs Topic moved to unit-5	-----
Unit-5 Searching and sorting:	-----	-----

It is resolved and recommend the changes in the syllabus of course code: CSCT21B Course: Data Structures from the academic year 2021-22 onwards for IBSC(MPCS,MCCS,MSCS), II Semester.

A.G & S.G.SIDDHARTHA DEGREE COLLEGE OF ARTS & SCIENCE

Vuyyuru-521165. NAAC recredited at 'A' level

Autonomous -ISO 9001 – 2015 Certified

Title of the Paper: Data Structures

Semester: II

Course Objectives

To introduce the fundamental concept of data structures and to emphasize the importance of various data structures in developing and implementing efficient algorithms.

Course Outcomes:

COURSE OUTCOME NO	Upon successful completion of the course, student will be able to:	PROGRAM OUTCOME NO
CO1	Learn the concepts of ADT and understand analysis of algorithms	PO1, PSO1, PSO2, PSO4
CO2	Understand available Data Structures for data storage and processing.	PO1, PSO1, PSO2, PSO4
CO3	Learn stacks, queues and their applications	PO1, PSO1, PSO2, PSO4
CO4	Understand trees, graphs and implement their operations	PO1, PO7, PSO1, PSO2, PSO4
CO5	Develop ability to implement different Sorting and Search methods	PO1, PO7, PSO1, PSO2, PSO4

Syllabus

UNIT – I:

11Periods

Introduction to Data Structures: Introduction to the Theory of Data Structures, Data Representation, Abstract Data Types, Data Types, Primitive Data Types, Data Structure and Structured Type, Atomic Type, Difference between Abstract Data Types, Data Types, and Data Structures, Refinement Stages.

Principles of Programming and Analysis of Algorithms: Software Engineering, Program Design, Algorithms, Different Approaches to Designing an Algorithm, Complexity, Big ‘O’ Notation, Algorithm Analysis, Recursion.

UNIT – II:

11Periods

Linked Lists: Introduction to Lists and Linked Lists, Basic Linked List Operations, Doubly Linked List, Circular Linked List, Atomic Linked List, Linked List in Arrays, Linked List versus Arrays

UNIT – III:

14Periods

Stacks: Introduction to Stacks, Stack as an Abstract Data Type, Representation of Stacks through Arrays, Representation of Stacks through Linked Lists, Applications of Stacks, Stacks and Recursion

Queues: Introduction, Queue as an Abstract data Type, Representation of Queues, Circular Queues, Double Ended Queues- De-ques, Priority Queues, Application of Queues

UNIT – IV:

10Periods

Binary Trees: Introduction to Non- Linear Data Structures, Introduction Binary Trees, Types of Trees, Basic Definition of Binary Trees, Properties of Binary Trees, Representation of Binary Trees, Operations on a Binary Search Tree, Binary Tree Traversal, Counting Number of nodes in Binary Trees, Applications of Binary Tree

UNIT – V:

14Periods

Searching and sorting: Sorting – An Introduction, Bubble Sort, Insertion Sort, Merge Sort, searching – An Introduction, Linear or Sequential Search, Binary Search, Indexed Sequential Search

Graphs: Introduction to Graphs, Terms Associated with Graphs, Sequential Representation of Graphs, Linked Representation of Graphs, Traversal of Graphs, Spanning Trees, Shortest Path, Application of Graphs.

BOOKS:

- “Data Structures using C”, ISRD group Second Edition, TMH
- Data Structures through C”, Yashavant Kanetkar, BPB Publications
- “Data Structures Using C” Balagurusamy E. TMH

RECOMMENDED CO-CURRICULAR ACTIVITIES:

(Co-curricular activities shall not promote copying from textbook or from others work and shall encourage self/independent and group learning)

A. Measurable

1. Assignments (in writing and doing forms on the aspects of syllabus content and outside the syllabus content. Shall be individual and challenging)
2. Student seminars (on topics of the syllabus and related aspects (individual activity))
3. Quiz (on topics where the content can be compiled by smaller aspects and data (Individuals or groups as teams))
4. Study projects (by very small groups of students on selected local real-time problems pertaining to syllabus or related areas. The individual participation and contribution of students shall be ensured (team activity))

B. General

1. Group Discussion
2. Others

RECOMMENDED CONTINUOUS ASSESSMENT METHODS:

Some of the following suggested assessment methodologies could be adopted;

1. The oral and written examinations (Scheduled and surprise tests),
2. Closed-book and open-book tests,
3. Programming exercises,
4. Practical assignments and laboratory reports,
5. Observation of practical skills,
6. Individual and group project reports.
7. Efficient delivery using seminar presentations,
8. Viva voce interviews.
9. Computerized adaptive testing, literature surveys and evaluations,
10. Peers and self-assessment, outputs form individual and collaborative work.

A.G & S.G.SIDDHARTHA DEGREE COLLEGE OF ARTS & SCIENCE

Vuyyuru- 521165. NAAC reaccredited at 'A' level

Autonomous -ISO 9001 – 2015 Certified

MODEL Question Paper: 2021-2022

TITLE: DATA STRUCTURES

COURSE CODE: CSCT21B

SECTIONS: B.Sc. (MPCS / MCCS / MSCS) SEMESTER: II

TIME: 3 Hrs.

MAX: 75M

SECTION –A

ANSWER ANY FIVE QUESTIONS

5 X 5 =25 M.

1. What is an ADT? Explain with an example. {CO₁, L2}
2. Explain about algorithm analysis. {CO₁, L2}
3. Distinguish between linked lists and arrays. {CO₂, L2}
4. Evaluate the postfix expression $2\ 3\ 1\ * +\ 9\ -$. {CO₃, L5}
5. Explain about min and max priority queues. {CO₃, L2}
6. Construct binary tree from the following in order and pre order traversals

In order: D B E A F C

Pre order: A B D E C F {CO₄, L3}

7. Explain various representations of graphs with your own example. {CO₅, L2}
8. Develop a C program for linear search. {CO₅, L3}

SECTION – B

ANSWER ALL THE QUESTIONS

5 X 10 =50 M.

- 9 a) Explain about Data structure, structured type and atomic type. {CO₁, L2}
(Or)
b) Explain about Time Complexity and Space Complexity. {CO₁, L2}
- 10 a) Explain about inserting and deleting a node in double linked list. {CO₂, L2}
(Or)
b) Explain about insertion in atomic node linked list. {CO₂, L2}
- 11 a) Develop a C program for stack's using arrays. {CO₃, L3}
(Or)
b) Develop a C program for circular queues. {CO₃, L3}
- 12 a) Explain about binary tree traversals with an example. {CO₄, L2}
(Or)
b) Demonstrate with an example deleting a node in a binary search tree. {CO₄, L2}
- 13 a) Illustrate Merge sort with an example and write code for it. {CO₅, L2}
(Or)
b) Illustrate Depth First search with an example. {CO₅, L2}

A.G & S.G.SIDDHARTHA DEGREE COLLEGE OF ARTS & SCIENCE

Vuyyuru- 521165. NAAC recredited at 'A' level

Autonomous -ISO 9001 – 2015 Certified

BLUE PRINT

TITLE: DATA STRUCTURES
SECTIONS: B.SC(MPCS / MCCS / MSCS)
TIME: 3 Hrs.

COURSE CODE: CSCT21B
SEMESTER: II
MAX: 75M

SECTION-A

ANSWER ANY FIVE QUESTIONS

5X5=25M

1. Unit 1
2. Unit 1
3. Unit 2
4. Unit 3
5. Unit 3
6. Unit 4
7. Unit 5
8. Unit 5

SECTION – B

ANSWER ALL THE QUESTIONS

5 X 10 =50 M.

- 9 a)Unit 1.
(Or)
b) Unit 1.
- 10 a) Unit 2.
(Or)
b) Unit 2.
- 11 a)Unit 3.
(Or)
b) Unit 3.
- 12 a) Unit 4.
(Or)
b) Unit 4.
- 13 a) Unit 5.
(Or)
b) Unit 5.

AG & SG SIDDHARTHA COLLEGE OF ARTS AND SCIENCES - VUYYURU.

An Autonomous college within the jurisdiction of Krishna University A.P, India.

Semester II	Course Code	Course Title	Hours	Credits
BSC(MPCS/MCCS/MSCS)	CSCT21B	Data Structures Lab	30	1

COURSE OUTCOME NO	Upon successful completion of this course, students should have the knowledge and skills to:	PROGRAM OUTCOME NO
CO1	Implement stacks, queues using arrays and linked lists.	PO1, PSO1, PSO2, PSO4
CO2	Write program for conversion from infix to postfix.	PO1, PSO1, PSO2, PSO4
CO3	Implement different sorting and searching techniques.	PO 7, PSO1, PSO2, PSO4
CO4	Construct binary trees and binary search trees.	PO 1, PSO1, PSO2, PSO4
CO5	implement binary tree and Graph traversals.	PO1,PO 7, PSO1, PSO2, PSO4

Lab Experiments List

Cycle - I

Week 1: Write a program to read 'N' numbers of elements into an array and also perform the following operation on an array

- Add an element at the beginning of an array
- Insert an element at given index of array
- Update a element using a values and index
- Delete an existing element

Week 2: Write Program to implement the Stack operations using an array.

Week 3: Write a program using stacks to convert a given infix expression to postfix.

Week 4: Write a program for arithmetic expression evaluation.

Week 5: Write Program to implement the Stack operations using Liked List.

Week 6: Write Program to implement the Queue operations using an array.

Week 7: Write Program to implement the Queue operations using Liked List.

Week 8: Write Program to implement circular Queue operations using an array.

Cycle - II

Week 9: Write a program to implement de-queues.

Week 10: Write a program to implement single linked list.

Week 11: Write a program to implement double linked list.

Week 12: Write a program for Binary Search Tree Traversals.

Week 13: Write a program to search an item in a given list using the following Searching Algorithms

- Linear Search
- Binary Search.

Week 14: Write a program for implementation of the following Sorting Algorithms

- Bubble Sort
- Insertion Sort
- Merge sort

Week 15: Write a program for implementation of the following graph traversals.

- BFS
- DFS



A.G. & S.G. Siddhartha Degree College of Arts & Science
Vuyyuru-521165, Krishna District, Andhra Pradesh
 (An Autonomous institution in the jurisdiction of Krishna University, Machilipatam)
 NAAC "A" Grade, ISO 9001:2015 Certified Institution

DEPARTMENT OF COMPUTER SCIENCE

Minutes of the meeting of Board of Studies in Computer Science for UG held on 07-04-2022 in the Department of Computer Science.

Semester	: II	Programme	: BCOM(CA)
Course	: E-COMMERCE & WEB DESIGNING	Course Code	: CABT21A
Course delivery method	: Class room / Blended	Credits	: 4
Credits	: 4	CIA marks	: 25
No. of lecture hours / week	: 4	Semester end exam	: 75
Total no. of lecture hours	: 60	Total marks	: 100
Year of Introduction	: 2021-22	Year of Revision	: 2021-22
% of revision:	: 100%		

Course content suggested by APSICHE	Additions	Deletions
Unit - 1 Introduction, Electronic Commerce	An Overview on E-Commerce Business Models for Ecommerce	-----
Unit - 2 payment System	E-Marketing & E - CRM & Electronic Payment Systems Online Marketing	-----
Unit - 3 On-line Business Transactions:	Electronic Payment Systems	-----
Unit-4 Introduction to HTML	Introduction to Web Designing HTML	-----
Unit-5 Website Designing: Hyperlinks:	Website Designing: Hyperlinks topic moved to UNIT-4 Introduction to WIX Editor Getting Started with Wix	-----

It is resolved and recommend the changes in the syllabus of course code: CABT21A Course: **E-COMMERCE & WEB DESIGNING** from the academic year 2021-22 onwards for IBCOM(CA), II Semester.

A.G & S.G.SIDDHARTHA DEGREE COLLEGE OF ARTS & SCIENCE

Vuyyuru-521165. NAAC recredited at 'A' level

Autonomous -ISO 9001 – 2015 Certified

Title of the Paper: **E-COMMERCE & WEB DESIGNING**

Semester: II

COURSE OBJECTIVES:

The main objective of the course is to impart conceptual understanding on business transactions on worldwide web and electronic commerce & Electronic Customer Relationship Management and Web designing concepts for providing quality content on website.

COURSE OUTCOMES:

COURSE OUTCOME NO	Upon successful completion of this course, students should have the knowledge and skills to
CO1	Understand the structure of HTML its basic tags
CO2	Implement various HTML tags for web page development
CO3	Understand about implementing forms and frames in web page designing
CO4	Gain knowledge in E- commerce and its business models
CO5	Differentiate traditional and e – marketing and also gain knowledge in E-CRM and EPS

UNIT I: An Overview on E-Commerce

(10periods)

Introduction E-Commerce

Definition of E- Commerce and its advantages & disadvantages

Electronic Data Interchange (EDI)

E-Commerce transactional issues and challenges

Difference between Commerce and E-Commerce

Business Models for Ecommerce

B2C -Business to consumer. B2B – Business to business C2B – Consumer to business. C2C – Consumer to consumer.

UNIT II: E-Marketing &E – CRM& Electronic Payment Systems

(10periods)

Online Marketing

Traditional Vs. E-Marketing

Online Marketing

E-Advertising

Internet marketing

E – CRM

Definition of CRM and E-CRM and its Applications

E- CRM Architectural components

Definition & characteristics of E- SCM

Benefits and goals of E – SCM 2.2.5 E-Logistics of UP

UNIT III: Electronic Payment Systems

(10periods)

Types of EPS

Traditional payment system and modern payment system

Steps for electronic payment 3.4 Payment security

UNIT IV: Introduction to Web Designing

(12periods)

4.1 HTML

4.1.1 Define HTML 4.1.2 Structure of HTML 4.1.3 Basic HTML tags

4.1.4 Formatting HTML tags

Lists

Ordered List 4.2.2 Unordered List

4.3Links

4.3.1 Link tag 4.3.2 Image tag 4.3.3 Marquee tag 4.4Tables

4.4.1 Table Creation 4.4.2 Attributes of Table

4.5forms& Frames

4.5.1 Forms creation 4.5.2 Form tag 4.5.3 Input fields of form

4.5.4 Frame Creation 4.5.5 Frameset tag 4.5.6 Frame tag

UNIT V: Introduction to WIX Editor

(18periods)

Getting Started with Wix

Adding and Editing Text

Adding a Site Title

Changing Your Text Font

Creating a Clickable URL

Adding Language Fonts

Adding Elements to Your Site

Arranging the Content on Your Site's Pages

About the Header

About the Footer

Adding an Image to Your Page Background

Uploading Your Own Background Image

Adding a Video to Your Page Background

Uploading Your Own Video Page Background

Uploading Your Own Images

Adding a Logo to Your Site

Adding a Link to an Image

Gallery and Button

Adding a Gallery

Cropping and Editing Gallery Images

Adding and Setting Up an Icon Button

Adding a Link to a Button

Video

Adding a Video from YouTube

Retrieving a YouTube URL

Menu

Adding a Site Menu

Customizing Your Menu Design

Adding and Deleting a Menu Folder

Reordering Menu Items

Changing the Direction of Menu Items

Text Book:

1. Uttam Kumar Roy, Web Technologies, Oxford University Press.
2. E-Commerce- A Managerial Perspective- P. T. Joseph, Prentice- Hall of India, New Delhi, 2005.

References:

1. Kogent Learning Solutions Inc.(Author), "Black Book HTML 5.0", dramatic.
- 2.Daniel Amor, E-Business R(Evolution), Pearson Edude, New Delhi, 2005.

Weblink: <https://support.wix.com/en/the-wix-editor/editor-basics>

A.G & S.G.SIDDHARTHA DEGREE COLLEGE OF ARTS & SCIENCE

Vuyyuru- 521165. NAAC reaccredited at 'A' level

Autonomous -ISO 9001 – 2015 Certified

**Title: E-Commerce Web Designing
Model Paper**

**CLASS: B.Com (Computer Applications)
Semester: II**

Course Code: CABT21A

**Max. Marks: 75M
Time: 3 Hours**

Section-A

ANSWER ANY FIVE QUESTIONS

5X5M=25M

1. Explain the E-Commerce (CO1, L2)
2. Compare Traditional marketing and E-Marketing. (CO2, L2)
3. Define Networks and its types? (CO3, L1)
4. Explain Link tags in HTML (CO4, L2)
5. Explain the steps to add a link to a button (CO5, L1)
6. Compare Commerce and E-Commerce. (CO1, L2)
7. Explain Benefits and goals of E – SCM. (CO2, L2)
8. Demonstrate concept of formatting Tags (CO4, L2)

Section-B

ANSWER THE FOLLOWING QUESTIONS

5X10M=50M

9. (A) Explain EDI. (CO1, L2)
(OR)
(B) Classify Business Models for Ecommerce. (CO1, L2)
10. (A) Illustrate E- CRM Architectural components. (CO2, L2)
(OR)
(B) Explain Electronic Payment Systems. (CO2, L2)
11. (A) Define Structure of HTML with examples (CO3, L1)
(OR)
(B) What are different types Network Topologies? (CO3, L1)
12. (A) Demonstrate the concept of Table creation with apply all Attributes. (CO4, L2)
(OR)
(B) Define forms in html and creation of form with all input types? (CO4, L1)
13. (A) Explain the steps to add elements to your site. (CO5,L1)
(OR)
(B) How to add images and logo to your site (CO5, L1)

AG & SG SIDDHARTHA COLLEGE OF ARTS AND SCIENCES - VUYYURU.
An Autonomous college within the jurisdiction of Krishna University A.P, India.

<i>Computer Science</i>	CABT21A	2021-22	B. Com (Computers Applications)
-------------------------	----------------	----------------	--

Semester - II

Credits: 1

WEB DESIGNING LAB

COURSE OBJECTIVES:

The purpose of this course is to introduce to students to the field of creation web pages using HTML language. The students will be able to enhance their analyzing and help to creation for Web Site Design

COURSE OUTCOMES:

COURSE OUTCOME NO	on successful completion of this course, students should have the knowledge and skills to
CO1	Implement HTML tags.
CO2	Implementing lists and tables in web pages.
CO3	Implementing frames in web pages.
CO4	Implementing frames in web pages.
CO5	Application of CSS in a web page.

Week 1: Write a HTML program to print text in bold and italic font.

Week 2: Write a HTML program to print Heading tags.

Week 3: Write a HTML program using Text formatting tags

Week 4: Write a HTML program to implement unordered lists. Write a HTML program to implement order lists.

Week 5: Write a html file which display 3 images at LEFT, RIGHT and CENTER respectively in the browser.

Week 6: Create a HTML file which contains hyperlinks.

Week 7: Write a HTML program to create a table

Week 8: Write a HTML program to create a table using Row Span and Cols pan.

Week 9: Write a HTML program to Create a simple form

Week 10: Create a Registration form that interacts with the user. Collect login name, password, date of birth, gender, address, qualification.

Week 11: Create a HTML page using frameset tag.

Developing Websites using WIX: <https://www.wix.com/blog/2020/05/how-to-design-a-website/>

Week 12: An online store to sell your products.

Week 13: A photography website to display and sell prints.

Week 14: A fitness website to book new clients.

Week 15: A restaurant website to help with online orders, delivery and payment.

A.G & S.G.SIDDHARTHA DEGREE COLLEGE OF ARTS & SCIENCE

Vuyyuru-521165. NAAC reaccruited at 'A' level

Autonomous -ISO 9001 – 2015 Certified

Title of the Paper: **Information Technology**

Semester: II

Course Code	CABT21A	Course Delivery Method	Class Room / Blended Mode – Both
Credits	4	CIA Marks	25
No. of Lecture Hours / Week	4	Semester End Exam Marks	75
Total Number of Lecture Hours	60	Total Marks	100
Year of Introduction :2020-21	Year of Offering: 2021 - 22	Year of Revision: ----	Percentage of Revision: 0%

COURSE OBJECTIVES:

It provides to learn computer basics and basic principles of using Windows operation system and be able to access the Internet, data communication, Software, hardware and various new technologies in information technology.

Course Outcomes:

COURSE OUTCOME NO	Upon successful completion of this course, students should have the knowledge and skills to
CO1	Understand fundamental concepts of a computer and its basic components
CO2	Understand basic functioning of an operating system and customizing Windows Desktop
CO3	Analyze type of soft ware's and programming languages
CO4	Have knowledge in basic Network and Data Communication Concepts
CO5	Understand the need of data mining and get familiarize with basics of new concepts like KDD, OLAP

AG & SG SIDDHARTHA COLLEGE OF ARTS AND SCIENCES - VUYYURU.
An Autonomous college within the jurisdiction of Krishna University A.P, India.
 (With Effect from Academic Year 2021-22)

Semester II	Course Code	Course Title	Credits	Periods
B.Com.(E-Commerce Computer)	CABT21A	Information Technology	4	75

UNIT-I: INTRODUCTION:

13Periods

Introduction to computers
 Generations of computers
 An overview of computer system - Types of computers
 Input & Output Devices.
 Hardware: Basic components of a computer system- Control unit– ALU- Input/output functions.
 Memory – RAM – ROM – EPROM - PROM and Other types of memory.

UNIT-II: OPERATING SYSTEM (OS):

12Periods

Meaning - Definition & Functions.
 Types of OS - Booting process
 DOS – Commands (internal & external) - Wild card characters
 Windows: Using the Start Menu –Control Panel – Using multiple
 Windows – Customizing the Desktop – Windows accessories (Preferably latest version of windows or Linux Ubuntu).

Unit-III: SOFTWARE:

15Periods

System software and application software.
 Operating system windows OS,
 Mobile device operating system and notebook operating systems
 Application software Types of personal application software
 Spread sheet-data management
 Word processing
 Desktop publishing
 Graphics, CAD, CAM, CIM
 Programming Languages
 Assembly language
 Procedural language, non-procedural language, natural programming language.
 Hypertext mark-up language, modeling language, object-oriented programming language.

Unit-IV: DATA COMMUNICATION:

20 Periods

Telecommunication and Networks Communication media & channel cable media

 Broad cast media channels twisted pair
 Coaxial cable, fibers optical cable, micro wave, satellite, radio, cellular radio,
 Infrared global positioning system.
 Introduction, Analog and Digital signals, modulation need of modulations, modems.
 Telecommunication System communication processors:
 Modem
 Multiplexers
 Front –end-processor.
 Networks LAN, WAN, VAN, virtual private network (VPN).
 Internet, intranet and Extranets
 The evolution of the internet, service provided by the internet, World Wide Web.

Unit-V: NEW TECHNOLOGIES:**10 Periods**

New technologies in Information Technology:

Introduction to hyper media, artificial intelligence and business intelligence, knowledgediscovery in database (KDD)
Data warehouse and data marts. Data mining and OLAP.

Student Activity:

Students have to submit assignments and give seminars on various topics allotted to them.

Total of 5 Hrs is allotted for student seminars. Student activity also includes gathering of information related to latest technologies in computers.

Library Activity:

Students will visit library in their allotted time and will refer various text books to gather information for their assignments.

TEXT/ REFERENCE BOOKS:

1. B.E.V.L.Naidu, V.V.. Devi Prasad Konti, Ganti Naga Srikanth, Himalaya publishing House.
2. Introduction to Computers: Peter Norton, McGraw Hill

@@@@

AG & SG SIDDHARTHA COLLEGE OF ARTS AND SCIENCES - VUYYURU.
An Autonomous college within the jurisdiction of Krishna University A.P, India.

(With Effect from Academic Year 2021-22)

MODEL Question Paper:

PAPER TITLE: INFORMATION TECHNOLOGY

COURSE CODE: CABT21A

CLASS: B.Com (E-Commerce-Computers)

SEMESTER: II

TIME: 3 Hrs.

MAX: 75M

SECTION – A

Answer any five of the following

5X5 =25M

1. Illustrate the characteristics of RAM and ROM. (CO1, L2)
2. Define Operating system. What are different types of OS? (CO2, L1)
3. Demonstrate application software and system software. (CO3, L2)
4. What are the different types of networks? (CO4, L1)
5. Explain the steps involved in the process of KDD. (CO5, L2)
6. Explain about input devices. (CO1, L2)
7. What are analog and digital signals? (CO4, L1)
8. Explain Data warehouse. (CO5, L2)

SECTION –B

Answer the following

5x10=50M

9. a) Explain the block diagram of computer. (CO1, L2)

OR

- b) Explain the generations of computers. (CO1, L2)

10. a) What are the functions of operating system? (CO2, L1)

OR

- b) What are DOS Internal and External commands? (CO2, L1)

11. a) Explain the characteristics of various types of programming languages. Give examples. (CO3, L2)

OR

- b) Summarize the concepts on CAD, CAM and CIM. (CO3, L2)

12. a) Define the various types of Communication media and channels. (CO4, L1)

OR

- b) What are the Advantages and Disadvantages of Internet? (CO4, L1)

13. a) Demonstrate On-Line Analytical process (OLAP). (CO5, L2)

OR

- b) Explain about Artificial Intelligence and Business Intelligence. (CO5, L2)

@@@

A.G & S.G.SIDDHARTHA DEGREE COLLEGE OF ARTS & SCIENCE

Vuyyuru-521165. NAAC reaccredited at 'A' level

Autonomous -ISO 9001 – 2015 Certified

Title of the Paper: **COMPUTER APPLICATIONS**

Semester: II

Course Code	CABT22A	Course Delivery Method	Class Room / Blended Mode – Both
Credits	3	CIA Marks	25
No. of Lecture Hours / Week	4	Semester End Exam Marks	75
Total Number of Lecture Hours	60	Total Marks	100
Year of Introduction :2020-21	Year of Offering: 2021 - 22	Year of Revision: ----	Percentage of Revision: 0%

COURSE OBJECTIVES:

It provides to learn computer basics and basic principles of using Windows operation system and be able to access the Ms-Office, Power Point, Excel and various new technologies in information technology.

Course Outcomes:

COURSE OUTCOME NO	Upon successful completion of this course, students should have the knowledge and skills to
CO1	Understand fundamental concepts of a computer and its basic components
CO2	Understand basic functioning of an Ms-Office and MS-Word Window Components Windows Desktop
CO3	Analyze type of soft ware's and programming languages
CO4	Have knowledge in MS-Excel and MS Access
CO5	Understand the need of Finding, Sorting and Displaying Data and get familiarize

AG & SG SIDDHARTHA COLLEGE OF ARTS AND SCIENCES - VUYYURU.

An Autonomous college within the jurisdiction of Krishna University A.P, India.

(With Effect from Academic Year 2021-'22)

COMPUTER SCIENCE	CABT22A	2021-'22	B.Com(E-Commerce-computers)
-------------------------	----------------	-----------------	------------------------------------

SEMESTER – II PAPER – II Max. Marks 75 Pass Marks 30 Total Hrs: 60

Syllabus COMPUTER APPLICATIONS NO. Of Hrs: 4 Credits: 3

Unit-I: MS-Word

10 Hrs

Features of MS-Word – MS-Word Window Components – Creating, Editing, Formatting and Printing of Documents – Headers and Footers – Insert/Draw Tables, Table Auto format – Page Borders and Shading – Inserting Symbols, Shapes, Word Art, Page Numbers, Equations – Spelling and Grammar – Thesaurus – Mail Merge

Unit-II: MS-PowerPoint

10 Hrs

Features of PowerPoint – Creating a Blank Presentation - Creating a Presentation using a Template - Inserting and Deleting Slides in a Presentation – Adding Clip Art/Pictures - Inserting Other Objects, Audio, Video - Resizing and scaling of an Object – Slide Transition – Custom Animation

Unit-III: MS-Excel

10Hrs

Overview of Excel features – Creating a new worksheet, Selecting cells, Entering and editing Text, Numbers, Formulae, Referencing cells – Inserting Rows/Columns – Changing column widths and row heights, auto format, changing font sizes, colors, shading and attributes – Data Sorting and Filters – Functions – Functions requiring Addins, Functions by category Creating different types of Charts

Unit-IV: MS Access:

12Hrs

Creating a Simple Database and Tables: Features of Ms-Access, Creating a Database, Parts of Access. Tables: table creation using design view, table wizard, data sheet view, import table, link table. Forms: The Form Wizard, design view, columnar, tabular, data sheet, chart wizard.

Unit- V: Finding, Sorting and Displaying Data:

12Hrs

Queries and Dynasts, Creating and using select queries, Returning to the Query Design, Multi-level sorts, Finding incomplete matches, showing All records after a Query, saving queries - Crosstab Queries. Printing Reports: Form and Database Printing..

Reference Books:

1. Ron Mansfield, Working in Microsoft Office, Tata McGraw Hill(2008)
2. Ed Bott, Woody Leonhard, Using Microsoft Office 2007, Pearson Education(2007)
3. Sanjay Saxsena, Microsoft Office, 4.Microsoft Office, BPB Publications

AG & SG SIDDHARTHA COLLEGE OF ARTS AND SCIENCES - VUYYURU.
An Autonomous college within the jurisdiction of Krishna University A.P, India.
(With Effect from Academic Year 2021-22)

COMPUTER SCIENCE	CABT22A	2021-'22	B.Com(e-commerce-computers)
-------------------------	----------------	-----------------	------------------------------------

SEMESTER – II

PAPER – III

Max. Marks 75

Model Paper: COMPUTER APPLICATIONS NO of Hours: 4 No Of Credits: 3 Pass Marks 30
Section-A

*Answer any **FIVE** Questions. Each question carries **FIVE** Marks 5x5=25M*

1. UNIT -1 5M
2. UNIT -1 5M
3. UNIT -2 5M
4. UNIT -2 5M
5. UNIT -3 5M
6. UNIT -3 5M
7. UNIT -4 5M
8. UNIT -5 5M

Section-B

*Answer All Questions. Each question carries **TEN** Marks 5X10=50M*

- 9.a) UNIT -1 10M
(Or)
- b). UNIT -1 10M
10. a) UNIT -2 10M
(Or)
- b). UNIT -2 10M
11. a) UNIT -3 10M
(Or)
- b). UNIT -3 10M
12. a) UNIT -4 10M
(Or)
- b). UNIT -4 10M
13. a) UNIT -5 10M
(Or)
- b). UNIT -5 10M

A.G & S.G.SIDDHARTHA DEGREE COLLEGE OF ARTS & SCIENCE

Vuyyuru-521165. NAAC recredited at 'A' level

Autonomous -ISO 9001 – 2015 Certified

Title of the Paper: DIGITAL MARKETING

Course Code	SDCCSC02	Course Delivery Method	Class Room / Blended Mode – Both
Credits	2	CIA Marks	10
No. of Lecture Hours / Week	2	Semester End Exam Marks	40
Total Number of Lecture Hours	30	Total Marks	50
Year of Introduction :2020-21	Year of Offering: 2021 - 22	Year of Revision: ----	Percentage of Revision: 0%

Objective:

The aim of the Digital Marketing Course is to provide students with the knowledge about business advantages of the digital marketing and its importance for marketing success. The application of the gained knowledge, skills and competences will help students in forming digital marketing plan in order to manage a digital marketing performance efficiently.

Course Outcomes:

COURSE OUTCOME NO	on successful completion of this course, students should have the knowledge and skills to
CO1	Understand fundamental concepts of Digital Marketing and Channels (PO1, PO7, PSO1, PSO4)
CO2	Understand how to optimize a Web site and SEO optimization (PO1, PO7, PSO1, PSO4)
CO3	Understand Social Media Plan for measuring effects of digital marketing (PO1, PO7, PSO1, PSO4)

UNIT-I: INTRODUCTION:

5 Periods

What is Digital Marketing?

Difference between Traditional Marketing and Digital Marketing?

Benefits of Digital Marketing?

Latest Digital Marketing Trends

Digital Marketing Platforms

Digital Marketing Strategies for Websites

Career Opportunities in Digital Marketing

Difference Between Digital Marketing , Online Marketing and Internet Marketing

Functions and Types of Digital marketing

What is Marketing and how to build Online Marketing Plan

Digital Marketing Process

How to increase Visibility and People Engagement

Traffic Generation Techniques , Leads and How to gauge Performance Evaluation

Digital Marketing Techniques for Product Marketing and Service Marketing

UNIT-II: SEO Training (Search Engine Optimization)

12Periods

Introduction to SEO
What are Search engines and How Search Engines Work
Search Engine Algorithms and Latest Updates
Keyword Research
Google Trends
Purpose of website analytics
How to choose Website Analysis Tools
Installing Google Analytics in website
Competitive Analysis
 Domain Registration and Hosting Plans
 Keyword Placement
 SEO Content Writing and Rewriting
 Google Webmaster Tools
 Sitemap Creation
 Robots.txt File Creation
 Google Updates and their effects in website Rankings.
 On page Optimization strategies

Unit-III:SEM Training (Search Engine Marketing)

13Periods

Introduction to Free and Paid Marketing
What is Search Engine Marketing?
What is Link Building
Advantages and Disadvantages of Link Building
Difference Between Search engines and Directories
Directory Submission Techniques
Classified Postings
Press Release Postings
 Article Posting Techniques
 Forum Postings
 Advantages and Disadvantages of Forums
 How and when to Participate in Groups
 Trade Fairs and Trade lead Postings
 Participating in Questions and Answers sites
 What are Do Follow and No Follow Links
SMO Training (Social Media Optimization)Introduction to social media optimization and Social Media Marketing
Twitter Marketing
Facebook Marketing, Facebook for Business , Advantages and Disadvantages
LinkedIn Account creation and LinkedIn Marketing
Social Bookmarking Sites, Advantages and Disadvantages of Submitting your website toSocial bookmarking Sites

TEXT/ REFERENCE BOOKS:

1. The Beginner's Guide to Digital Marketing (2015). Digital Marketer. Pulizzi,J.(2014) Epic Content Marketing, Mcgraw Hill Education.
2. Ryan, D. (2014). Understanding Digital Marketing: Marketing Strategies for Engaging the Digital Generation, Kogan Page Limited.
3. Chaffey, D., e-Marketing Excellence: Planning and Optimizing Your Digital Marketing, Burlington: Elsevier.

AG & SG SIDDHARTHA COLLEGE OF ARTS AND SCIENCES - VUYYURU.
An Autonomous college within the jurisdiction of Krishna University A.P, India.
(With Effect from Academic Year 2021-22)

MODEL Question Paper:

PAPER TITLE: Digital Marketing

COURSE CODE: SDCCSC02

SEMESTER: II

TIME: 2 Hrs.

MAX: 40M

SECTION – A

(Total: 4x7=28 Marks)

Answer any **four questions**. Each answer carries **7 marks**

- 1.
- 2.
- 3.
- 4.
- 5.
- 6.

SECTION – B

(Total: 6x2 = 12 Marks)

Answer any **Six questions**. Each answer carries **2 marks**

- 7.
- 8.
- 9.
- 10.
- 11.
- 12.
- 13.
- 14.
- 15.
- 16.

A.G & S.G.SIDDHARTHA DEGREE COLLEGE OF ARTS & SCIENCE

Vuyyuru-521165. NAAC recredited at 'A' level

Autonomous -ISO 9001 – 2015 Certified

Title of the Paper: OBJECT ORIENTATED PROGRAMMING THROUGH JAVA

Semester: IV

Course Code	CSCT01	Course Delivery Method	Class Room / Blended Mode – Both
Credits	3	CIA Marks	30
No. of Lecture Hours / Week	4	Semester End Exam Marks	70
Total Number of Lecture Hours	60	Total Marks	100
Year of Introduction :2020-21	Year of Offering: 2021 - 22	Year of Revision: ----	Percentage of Revision: 0%

Course Objective: To introduce the fundamental concepts of Object-Oriented programming and to design & implement object oriented programming concepts in Java.

Course Outcomes:

CO ₁	Understand the benefits of a well-structured program
CO ₂	Understand different computer programming paradigms
CO ₃	Understand underlying principles of Object-Oriented Programming in Java
CO ₄	Develop problem-solving and programming skills using OOP concepts
CO ₅	Develop the ability to solve real-world problems through software development in high-level programming language like Java

Syllabus

UNIT – I; Introduction to Java: Features of Java, The Java virtual Machine, Parts of Java

Naming Conventions and Data Types: Naming Conventions in Java, Data Types in Java, Literals

Operators in Java: Operators, Priority of Operators

Control Statements in Java: if... else Statement, do... while Statement, while Loop, for Loop, switch Statement, break Statement, continue Statement, return Statement

Input and Output: Accepting Input from the Keyboard, Reading Input with Java.util.Scanner Class, Displaying Output with System.out.printf(), Displaying Formatted Output with String.Format ()

Arrays: Types of Arrays, Three Dimensional Arrays (3D array), arrayname.length, Command Line Arguments

UNIT – II

Strings: Creating Strings, String Class Methods, String Comparison, Immutability of Strings

Introduction to OOPs: Problems in Procedure Oriented Approach, Features of Object-Oriented Programming System (OOPS)

Classes and Objects: Object Creation, Initializing the Instance Variables, Access Specifiers, Constructors

Methods in Java: Method Header or Method Prototype, Method Body, Understanding Methods, Static Methods, Static Block, The keyword 'this', Instance Methods, Passing Primitive Data Types to Methods, Passing Objects to Methods, Passing Arrays to Methods, Recursion, Factory Methods

Inheritance: Inheritance, The keyword 'super', The Protected Specifier, Types of Inheritance

UNIT – III

Polymorphism: Polymorphism with Variables, Polymorphism using Methods, Polymorphism with Static Methods, Polymorphism with Private Methods, Polymorphism with Final Methods, final Class

Type Casting: Types of Data Types, Casting Primitive Data Types, Casting Referenced Data Types, the Object Class

Abstract Classes: Abstract Method and Abstract Class

Interfaces: Interface, Multiple Inheritance using Interfaces

Packages: Package, Different Types of Packages, The JAR Files, Interfaces in a Package, Creating Sub Package in a Package, Access Specifiers in Java, Creating API Document

Exception Handling: Errors in Java Program, Exceptions, throws Clause, throw Clause, Types of Exceptions, Re – throwing an Exception

UNIT – IV

Streams: Stream, Creating a File using File Output Stream, Reading Data from a File using FileInputStream, Creating a File using File Writer, Reading a File using File Reader, Counting Number of Characters in a File, File Copy, File Class

Threads: Single Tasking, Multi Tasking, Uses of Threads, Creating a Thread and Running it, Terminating the Thread, Single Tasking Using a Thread, Multi Tasking Using Threads, Multiple Threads Acting on Single Object, Thread Class Methods, Deadlock of Threads, Thread Communication, Thread Priorities, thread Group, , Applications of Threads, Thread Life Cycle

UNIT – V

Applets: Creating an Applet, Uses of Applets, <APPLET> tag, A Simple Applet, An Applet with Swing Components, Animation in Applets, A Simple Game with an Applet, Applet Parameters

Java Database Connectivity: Database Servers, Database Clients, JDBC (Java Database Connectivity), Working with Oracle Database, Working with MySQL Database, Stages in a JDBC Program, Registering the Driver, Connecting to a Database, Preparing SQL Statements, Using jdbc–odbc Bridge Driver to Connect to Oracle Database, Retrieving Data from MySQL Database, Retrieving Data from MS Access Database, Stored Procedures and Callable Statements, Types of Result Sets

BOOKS:

1. Core Java: An Integrated Approach, Authored by Dr. R. Nageswara Rao & Kogent Learning Solutions Inc.
2. E. Balaguruswamy, Programming with JAVA, A primer, 3e, TATA McGraw-Hill Company.
3. John R. Hubbard, Programming with Java, Second Edition, Schaum's outline Series, TMH.
4. Deitel & Deitel. Java TM: How to Program, PHI (2007)

AG & SG SIDDHARTHA COLLEGE OF ARTS AND SCIENCES - VUYYURU.
An Autonomous college within the jurisdiction of Krishna University A.P, India.
(With Effect from Academic Year 2021-22)

COMPUTER SCIENCE	CSCT01	2021-'22	B.Sc.(MPCs,MCCs)
-------------------------	---------------	-----------------	-------------------------

SEMESTER – IV

PAPER – IV

Max. Marks 70

Model Paper: 'OBJECT ORIENTATED PROGRAMMING THROUGH JAVA'

NO of Hours: 4

No Of Credits: 3

Pass Marks 28

Section-A

Answer any FOUR Questions. Each question carries FIVE Marks

4x5=20M

1. UNIT -1..... 5M
2. UNIT -1..... 5M
3. UNIT -2..... 5M
4. UNIT -3..... 5M
5. UNIT -4..... 5M
6. UNIT -5..... 5M

Section-B

Answer any FIVE Questions. Each question carries TEN Marks

5X10=50M

7. UNIT -1 10M
8. UNIT -2 10M
9. UNIT -2 10M
10. UNIT -3 10M
11. UNIT -3 10M
12. UNIT -4 10M
13. UNIT -4 10M
14. UNIT -5 10M

AG & SG SIDDHARTHA COLLEGE OF ARTS AND SCIENCES - VUYYURU.
An Autonomous college within the jurisdiction of Krishna University A.P, India.
(With Effect from Academic Year 2021-22)

COMPUTER SCIENCE	CSCT01	2021-'22	B.Sc.(MPCs,MCCs)
------------------	---------------	----------	------------------

SEMESTER – IV PAPER –IV Max. Marks 70 Pass Marks 28
Guidelines for paper setting '**OBJECT ORIENTATED PROGRAMMING THROUGH JAVA**

Unit wise weight age of Marks

	Section-A (Short answer questions)	Section-B (essay questions)
Unit-1	2	1
Unit-2	1	2
Unit-3	1	2
Unit-4	1	2
Unit-5	1	1

- Each Short answer question carries 5 marks in Section –A
- Each Essay question carries 10 marks in Section –B
- The Question papers setters are requested to cover all the topics in the syllabus stipulated as per the weight age given by us

AG & SG SIDDHARTHA COLLEGE OF ARTS AND SCIENCES - VUYYURU.

An Autonomous college within the jurisdiction of Krishna University A.P, India.

(With Effect from Academic Year 2021-22)

COMPUTER SCIENCE	CSCT01P	2021-'22	B.Sc.(MPCS,MCCs)
------------------	---------	----------	------------------

SEMESTER – IV

PAPER – IV

Max. Marks 50

Lab List: OBJECT ORIENTATED PROGRAMMING THROUGH JAVA

No. of Hours per week: 2

External: 40

Internal: 10

Credits: 1

1. Write a program to read *Student Name, Regd.No, Marks [5]* and calculate Total, *Percentage, and Result*. Display all the details of students
2. Write a program to perform the following String Operations
 - a. Read a string
 - b. Find out whether there is a given substring or not
 - c. Compare existing string by another string and display status
 - d. Replace existing string character with another character
 - e. Count number of works in a string
3. Java program to implements Addition and Multiplication of two N X N matrices.
4. Java program to demonstrate the use of Constructor.
5. Calculate area of the following shapes using method overloading.
 - a. Triangle
 - b. Rectangle
 - c. Circle
 - d. Square
6. Implement inheritance between *Person (Aadhar, Surname, Name, DOB, and Age)* and *Student (Admission Number, College, Course, Year)* classes where ReadData(), Display Data() are overriding methods.
7. Java program for implementing Interfaces
8. Java program on Multiple Inheritance.
9. Java program for to display *Serial Number from 1 to N* by creating two Threads
10. Java program to demonstrate the following exception handlings
 - a. Divided by Zero
 - b. Array Index Out of Bound
 - c. File Not Found
 - d. Arithmetic Exception
 - e. User Defined Exception

11. Create an Applet to display different shapes such as Circle, Oval, Rectangle, Square and Triangle.
12. Write a program to create *Book (ISBN, Title, Author, Price, Pages, Publisher)* structure and store book details in a file and perform the following operations
 - a. Add book details
 - b. Search a book details for a given ISBN and display book details, if available
 - c. Update a book details using ISBN
 - d. Delete book details for a given ISBN and display list of remaining Books

**A.G & S.G.SIDDHARTHA DEGREE COLLEGE OF
ARTS & SCIENCE**

Vuyyuru-521165. NAAC reaccredited at 'A' level *Autonomous*
ISO 9001 – 2015 Certified

Title of the Paper: OPERATING SYSTEM

Semester: IV

Course Code	CSCT41C	Course Delivery Method	Class Room / Blended Mode – Both
Credits	3	CIA Marks	30
No. of Lecture Hours / Week	4	Semester End Exam Marks	70
Total Number of Lecture Hours	60	Total Marks	100
Year of Introduction :2020-21	Year of Offering: 2021 - 22	Year of Revision: ----	Percentage of Revision: 0%

Course Objective: This course aims to introduce the structure and organization of a file system. It emphasizes various functions of an operating system like memory management, process management, device management, etc.

.Course Outcomes:

CO ₁	Know Computer system resources and the role of operating system in resourcemanagement with algorithms
CO ₂	Understand Operating System Architectural design and its services
CO ₃	Gain knowledge of various types of operating systems including Unix and Android
CO ₄	Understand various process management concepts including scheduling,synchronization, and deadlocks.
CO ₅	Have a basic knowledge about multithreading.
CO ₆	Comprehend different approaches for memory management.

SYLLABUS

UNIT- I what is Operating System? History and Evolution of OS, Basic OS functions, Resource Abstraction, Types of Operating Systems– Multiprogramming Systems, Batch Systems, Time Sharing Systems; Operating Systems for Personal Computers, Workstations and Hand-held Devices, Process Control & Real time Systems.

UNIT- II Processor and User Modes, Kernels, System Calls and System Programs, System View of the Process and Resources, Process Abstraction, Process Hierarchy, Threads, Threading Issues, Thread Libraries; Process Scheduling, Non-Preemptive and Preemptive Scheduling Algorithms.

UNIT III Process Management: Deadlock, Deadlock Characterization, Necessary and Sufficient Conditions for Deadlock, Deadlock Handling Approaches: Deadlock Prevention, Deadlock Avoidance and Deadlock Detection and Recovery. Concurrent and Dependent Processes, Critical Section, Semaphores, Methods for Inter- process Communication; Process Synchronization, Classical Process Synchronization Problems: Producer-Consumer, Reader-Writer.

UNIT IV Memory Management: Physical and Virtual Address Space; Memory Allocation Strategies– Fixed and -Variable Partitions, Paging, Segmentation, Virtual Memory.

UNIT V File and I/O Management, OS security : Directory Structure, File Operations, File Allocation Methods, Device Management, Pipes, Buffer, Shared Memory, Security Policy Mechanism, Protection, Authentication and Internal Access Authorization Introduction to Android Operating System, Android Development Framework, Android Application Architecture, Android Process Management and File System, Small Application Development using Android Development Framework.

REFERENCE BOOKS:

1. Operating System Principles by Abraham Silberschatz, Peter Baer Galvin and Greg Gagne (7th Edition) Wiley India Edition.
2. Operating Systems: Internals and Design Principles by Stallings (Pearson)
3. Operating Systems by J. Archer Harris (Author), Jyoti Singh (Author) (TMH)
4. Online Resources for UNIT V

AG & SG SIDDHARTHA COLLEGE OF ARTS AND SCIENCES - VUYYURU.
An Autonomous college within the jurisdiction of Krishna University A.P, India.
(With Effect from Academic Year 2021-22)

COMPUTER SCIENCE	CSCT41C	2021-'22	B.Sc.(MPCs,MCCs)
SEMESTER – IV	PAPER – V	Max. Marks 70	

Model Paper: 'OPERATING SYSTEM

NO of Hours: 4

No Of Credits: 3

Pass Marks 28

Section-A

Answer any FOUR Questions. Each question carries FIVE Marks

4x5=20M

1. UNIT -1..... 5M
2. UNIT -1..... 5M
3. UNIT -2..... 5M
4. UNIT -3..... 5M
5. UNIT -4..... 5M
6. UNIT -5..... 5M

Section-B

Answer any FIVE Questions. Each question carries TEN Marks

5X10=50M

7. UNIT -1 10M
8. UNIT -2 10M
9. UNIT -2 10M
10. UNIT -3 10M
11. UNIT -3 10M
12. UNIT -4 10M
13. UNIT -4 10M
14. UNIT -5 10M

AG & SG SIDDHARTHA COLLEGE OF ARTS AND SCIENCES - VUYYURU.
An Autonomous college within the jurisdiction of Krishna University A.P, India.
(With Effect from Academic Year 2021-22)

COMPUTER SCIENCE	CSCT41C	2021-'22	B.Sc.(MPCs,MCCs)
------------------	----------------	----------	------------------

SEMESTER – IV PAPER –V Max. Marks 70 Pass Marks 28

Guidelines for paper setting '**OPERATING SYSTEM**'

Unit wise weight age of Marks

	Section-A (Short answer questions)	Section-B (essay questions)
Unit-1	2	1
Unit-2	1	2
Unit-3	1	2
Unit-4	1	2
Unit-5	1	1

- Each Short answer question carries 5 marks in Section –A
- Each Essay question carries 10 marks in Section –B
- The Question papers setters are requested to cover all the topics in the syllabus stipulated as per the weight age given by us

AG & SG SIDDHARTHA COLLEGE OF ARTS AND SCIENCES - VUYYURU.

An Autonomous college within the jurisdiction of Krishna University A.P, India.

(With Effect from Academic Year 2021-22)

COMPUTER SCIENCE	CSCT41C	2021-'22	B.Sc.(MPCS,MCCs)
-------------------------	----------------	-----------------	-------------------------

SEMESTER – IV

PAPER – V

Max. Marks 50

Lab List: OPERATING SYSTEM LAB USING C/JAVA

No. of Hours per week: 2

External: 40

Internal: 10

Credits: 1

1. Write a program to implement Round Robin CPU Scheduling algorithm
2. Simulate SJF CPU Scheduling algorithm
3. Write a program the FCFS CPU Scheduling algorithm
4. Write a program to Priority CPU Scheduling algorithm
5. Simulate Sequential file allocation strategies
6. Simulate Indexed file allocation strategies
7. Simulate Linked file allocation strategies
8. Simulate MVT and MFT memory management techniques
9. Simulate Single level directory File organization techniques
10. Simulate Two level File organization techniques
11. Simulate Hierarchical File organization techniques
12. Write a program for Bankers Algorithm for Dead Lock Avoidance
13. Implement Bankers Algorithm Dead Lock Prevention.
14. Simulate all Page replacement algorithms.
 - a) FIFO
 - b) LRU
 - c) LFU
15. Simulate Paging Techniques of memory management

A.G & S.G.SIDDHARTHA DEGREE COLLEGE OF ARTS & SCIENCE

Vuyyuru-521165. NAAC reaccredited at 'A' level

Autonomous -ISO 9001 – 2015 Certified

Title of the Paper: Database Management System

Semester: IV

Course Code	CCSC401G	Course Delivery Method	Class Room / Blended Mode – Both
Credits	3	CIA Marks	30
No. of Lecture Hours / Week	4	Semester End Exam Marks	70
Total Number of Lecture Hours	60	Total Marks	100
Year of Introduction :2020-21	Year of Offering: 2021 - 22	Year of Revision: ----	Percentage of Revision: 0%

Course Objective: The objective of the course is to introduce the design and development of databases with special emphasis on relational databases.

Course Outcomes:

CO ₁	Able to have knowledge about database, Traditional File System.
CO ₂	Be able to Design a database using Relation models and Data Modeling
CO ₃	Store, retrieve data in database using Integrity constraints and Normal Forms.
CO ₄	Be able to implement various SQL queries
CO ₅	Be able to implement various Procedural SQL queries and

AG & SG SIDDHARTHA COLLEGE OF ARTS AND SCIENCES - VUYURU.
An Autonomous college within the jurisdiction of Krishna University A.P, India.
(With Effect from Academic Year 2021-22)

COMPUTER SCIENCE	CCSC402G	2021-'22	B.Com.(CA)
SEMESTER – IV	PAPER – IV		Max. Marks 70

Syllabus: 'Database Management System

UNIT-I Overview of Database Management System

Introduction, Data and Information, Database, Database Management System, Objectives of DBMS, Evolution of Database Management System, Classification of Database Management System.

UNIT-2: File-Based System

File Based System. Drawbacks of File-Based System, DBMS Approach, Advantage of DBMS, Data Models, Components of Database System, Database Architecture, DBMS Vendors and their products.

UNIT-III: Entity-Relationship Model:

Introduction, The Building Blocks of an Entity-Relationship, Classification of Entity Set, Attribute Classification, Relationship Degree, Relationship Classification, Generalization and Specialization, Aggregation and Composition, CODD's Rules, Relational Data Model, Concept of Relational Integrity.

UNIT-IV: Structured Query Language

Introduction, History of SQL Standards, Commands in SQL, Data types in SQL, Data Definition Language (DDL), Selection Operation Projection Operation, Aggregate Functions, Data Manipulation Language, Table Modification, Table Truncation, Imposition of Constraints, Set Operations.

UNIT-V: PL/SQL:

Introduction, Structure of PL/SQL, PL/SQL Language Elements, Data Types, Control Structure, Steps to Create a PL/SQL Program, Iterative Control Cursors, Steps to Create a Cursor, Procedure, Functions, Packages, Exceptions Handling, Database Triggers, Types of triggers.

• **References:**

- Paneer selvam: Database Management system, PHI.
- David Kuklinski, Osborne, Data management system McGraw Hill Publication.
- Shgirley Neal And Kenneth LC Trunik Database management system in Business-PHI.
- Godeon C. EVEREST, Database Management-McGraw Hill Book Company.
- MARTIN, Database Management-Prentice Hall of India, New Delhi.
- Bipin C. Desai, 'An Introduction to Database System', Galgotia Publications
- Navathe, Database Management System.

AG & SG SIDDHARTHA COLLEGE OF ARTS AND SCIENCES - VUYURU.
An Autonomous college within the jurisdiction of Krishna University A.P, India.
(With Effect from Academic Year 2020-21)

COMPUTER SCIENCE	CCSC401G	2021-'22	B.Com.(C.A.)
-------------------------	-----------------	-----------------	---------------------

SEMESTER – IV

PAPER – IV

Max. Marks 70

Model Paper

DATA BASE MANAGEMENT SYSTEMS

NO of Hours: 5

No Of Credits: 3

Pass Marks 28

Section-A

*Answer any **FOUR** Questions. Each question carries **FIVE** Marks*

4x5=20M

1. UNIT -1..... 5M
2. UNIT -1..... 5M
3. UNIT -2..... 5M
4. UNIT -3..... 5M
5. UNIT -4..... 5M
6. UNIT -5..... 5M

Section-B

*Answer any **FIVE** Questions. Each question carries **TEN** Marks*

5X10=50M

7. UNIT -1 10M
8. UNIT -2 10M
9. UNIT -2 10M
10. UNIT -3 10M
11. UNIT -3 10M
12. UNIT -4 10M
13. UNIT -4 10M
14. UNIT -5 10M

AG & SG SIDDHARTHA COLLEGE OF ARTS AND SCIENCES - VUYURU.
An Autonomous college within the jurisdiction of Krishna University A.P, India.
(With Effect from Academic Year 2020-21)

COMPUTER SCIENCE	CCSC401G	2021-'22	B.Com.(C.A.)
-------------------------	-----------------	-----------------	---------------------

SEMESTER – IV

PAPER – IV

Max. Marks 70

Guidelines for paper setting '**DATA BASE MANAGEMENT SYSTEMS**'

Unit wise weight age of Marks

	Section-A (Short answer questions)	Section-B (essay questions)
Unit-1	2	1
Unit-2	1	2
Unit-3	1	2
Unit-4	1	2
Unit-5	1	1

- Each Short answer question carries 5 marks in Section –A
- Each Essay question carries 10 marks in Section –B
- The Question papers setters are requested to cover all the topics in the syllabus stipulated as per the weight age given by us

AG & SG SIDDHARTHA COLLEGE OF ARTS AND SCIENCES - VUYYURU.

An Autonomous college within the jurisdiction of Krishna University A.P, India.

(With Effect from Academic Year 2020-21)

COMPUTER SCIENCE	CCSC401P	2021-'22	B. COM(CA)
-------------------------	-----------------	-----------------	-------------------

SEMESTER –IV

PAPER – IV

Max. Marks 50

Lab List DATA BASE MANAGEMENT SYSTEMS

No. of Hours per week: 2

External: 40

Internal: 10

Credits: 1

1. Creation of college database and establish relationships between tables
2. Explain various data type in Oracle.
3. Show the structure of the Emp table.
4. Show the structure of the DEPT table.
5. Explain the syntax of SELECT statement.
6. Create a query to display the name, job, hiredate and employee number from emp table.
7. Create a query to display unique jobs from the emp table.
8. Create a query to display the empno as EMP#, ename as EMPLOYEE and Hire_date from emp.
9. Create a query to display all the data from the EMP table. Separate each column by a comma and name the column THE_OUTPUT.
10. Create a query to display the name and salary of employees earning more than 2850.
11. Create a query to display the name and salary for all employees whose salary is not in the range of 1500 and 2850.
12. Display the employee name, job and start date of employees hired between February 20, 1981 and May 1, 1981. Order the query in ascending order of start date
13. Display the employee name and department number of all the employees in departments 10 and 30 in alphabetical order by name.
14. List the name and salary of employees who earn more than 1500 & are in department 10 or 30.
15. Display the name, salary and commissions and sort data in descending order of salary and commission.
16. Display the name and job title of all employees who do not have a manager.
17. Display the name, job and salary for all employees whose job is Clerk or Analyst and their salary is not equal to 1000, 3000 or 5000.
18. Display the names of all employees where the third letter of their name is an 'A'.
19. Display the names of all employees who have two 'L's in their name and are in department 30 or their manager is 7782.
20. Display the name, salary and commission for all employees whose commission amount is greater than their salary increased by 10%.
21. Explain all the character functions.
22. Explain all the number functions.
23. Explain all the Date functions.

Create Student database using the following tables.

STUDENT: Sno : primary key, numbers name : NOT NULL, varchar2 Address:
Varchar2

COURSE:Sno : Foreign key.Course Name : varchar2

Queries:

1. Alter table by adding a column fees in table COURSE.
2. Alter table by modifying the address to VARCHAR2(20)
3. Create a view on which the students who joined in one course only.

PL/SQL.

1. Write A Pl/Sql Program To Swap Two Numbers Without Using Third Variable.
2. Write A Pl/Sql Program To Generate Multiplication Tables For Numbers 2,4 And 6
3. Write A Pl/Sql Program To Display Sum Of Even Numbers And Sum Of Odd Numbers In The Given Range.
4. Write A Pl/Sql Program To Check The Given Number Is Pollinndrome Or Not.
5. Write A Pl/Sql Program To Display Top 10 Rows In Emp Table Based On Their Job And Salary.

Reference Books:

1. Oracle Pl/Sql By Example. Benjamin Rosenzweig, Elena Silvestrova,
Pearsoneducation 3rd Edition
2. Sql& Pl/Sql For Oracle 10g, Black Book, Dr.P.S. Deshpande

A.G & S.G.SIDDHARTHA DEGREE COLLEGE OF ARTS & SCIENCE

Vuyyuru-521165. NAAC recredited at 'A' level

Autonomous -ISO 9001 – 2015 Certified

Title of the Paper: Object Oriented Programming with Java

Semester: IV

Course Code	CCSC402G	Course Delivery Method	Class Room / Blended Mode – Both
Credits	3	CIA Marks	30
No. of Lecture Hours / Week	4	Semester End Exam Marks	70
Total Number of Lecture Hours	60	Total Marks	100
Year of Introduction :2020-21	Year of Offering: 2021 - 22	Year of Revision: ----	Percentage of Revision: 0%

Course Objective: The objective of the course is to introduce the design and development of databases with special emphasis on relational databases.

Course Outcomes:

CO ₁	Understanding the meaning and necessity of audit in modern era
CO ₂	Comprehend the role of auditor in avoiding the corporate frauds
CO ₃	Identify the steps involved in performing audit process
CO ₄	Determine the appropriate audit report for a given audit situation
CO ₅	Apply auditing practices to different types of business entities

AG & SG SIDDHARTHA COLLEGE OF ARTS AND SCIENCES - VUYYURU.
An Autonomous college within the jurisdiction of Krishna University A.P, India.
(With Effect from Academic Year 2021-22)

COMPUTER SCIENCE	CCSC402G	2021-'22	B.Com.(CA)
SEMESTER – IV	PAPER – V	Max. Marks 70	

SYLLABUS: ‘OBJECT ORIENTATED PROGRAMMING THROUGH JAVA’

Unit I: Introduction to OOPs: Problems in Procedure Oriented Approach, Features of Object Oriented Programming

Introduction to Java: Features of Java, The Java Virtual Machine (JVM), Parts of Java program, Naming Conventions in Java, Data Types in Java, Operators in Java, Reading Input using scanner Class, Displaying Output using System. out.println (), Command Line Arguments.

Unit II: Control Statements in Java: if... else, do... while Loop, while Loop, for loop, Switch Statement, break Statement, continue Statement

Arrays: Types of Arrays, array name, length,

Strings: Creating Strings, String Class Methods, String Comparison, Immutability of Strings.

Unit III: Classes and Objects: Object Creation, Initializing the Instance Variables, Access Specifiers, Constructors

Inheritance: Inheritance, Types of Inheritance

Polymorphism: Method overloading, Operator overloading

Abstract Classes: Abstract Method and Abstract Class

Unit IV: Packages: Package, Different Types of Packages, Creating Package and Accessing a Package

Streams: Stream classes, Creating a File using File Output Stream, Reading Data from a File using File Input Stream, Creating a File using File Writer, Reading a File using File Reader

Unit V: Exception Handling: Errors in Java Program, Exceptions, throws Clause, throw Clause, Types of Exceptions

Threads: Single Tasking, Multi-Tasking, Uses of Threads, Creating a Thread and Running it, Terminating the Thread, Thread Class Methods.

References:

1. The Complete Reference JAVA Seventh Edition Herbert Schildt. Tata McGraw Hill Edition.
2. Core Java: An Integrated Approach, Dr. R. Nageswara Rao & Kogent Learning Solutions Inc.
3. E. Balaguruswamy, Programming with JAVA, A primer, 3e, TATA McGraw-Hill Company

Online Resources:

<https://stackify.com/java-tutorials/>

<https://www.w3schools.com/java/>

<https://www.javatpoint.com/java-tutorial>

<https://www.tutorialspoint.com/java/index.html>

AG & SG SIDDHARTHA COLLEGE OF ARTS AND SCIENCES - VUYYURU.
An Autonomous college within the jurisdiction of Krishna University A.P, India.
(With Effect from Academic Year 2021-22)

COMPUTER SCIENCE	CCSC402G	2021-'22	B.Com.(CA)
-------------------------	-----------------	-----------------	-------------------

SEMESTER – IV

PAPER – V

Max. Marks 70

Model Paper: 'OBJECT ORIENTATED PROGRAMMING THROUGH JAVA'

NO of Hours: 4

No Of Credits: 3

Pass

Marks 28

Section-A

Answer any FOUR Questions. Each question carries FIVE Marks

4x5=20M

1. UNIT -1..... 5M
2. UNIT -1..... 5M
3. UNIT -2..... 5M
4. UNIT -3..... 5M
5. UNIT -4..... 5M
6. UNIT -5..... 5M

Section-B

Answer any FIVE Questions. Each question carries TEN Marks

5X10=50M

7. UNIT -1 10M
8. UNIT -2 10M
9. UNIT -2 10M
10. UNIT -3 10M
11. UNIT -3 10M
12. UNIT -4 10M
13. UNIT -4 10M
14. UNIT -5 10M

AG & SG SIDDHARTHA COLLEGE OF ARTS AND SCIENCES - VUYYURU.
An Autonomous college within the jurisdiction of Krishna University A.P, India.
(With Effect from Academic Year 2021-22)

COMPUTER SCIENCE	CCSC402G	2021-'22	B.Com.(CA)
------------------	----------	----------	------------

SEMESTER – IV PAPER –V Max. Marks 70 Pass Marks 28
Guidelines for paper setting '**OBJECT ORIENTATED PROGRAMMING THROUGH
JAVA**

Unit wise weight age of Marks

	Section-A (Short answer questions)	Section-B (essay questions)
Unit-1	2	1
Unit-2	1	2
Unit-3	1	2
Unit-4	1	2
Unit-5	1	1

- Each Short answer question carries 5 marks in Section –A
- Each Essay question carries 10 marks in Section –B
- The Question papers setters are requested to cover all the topics in the syllabus stipulated as per the weight age given by us

AG & SG SIDDHARTHA COLLEGE OF ARTS AND SCIENCES - VUYYURU.

An Autonomous college within the jurisdiction of Krishna University A.P, India.

(With Effect from Academic Year 2021-22)

COMPUTER SCIENCE	CCSC402P	2021-'22	B.Com.(CA)
-------------------------	-----------------	-----------------	-------------------

SEMESTER – IV

PAPER – V

Max. Marks 50

Lab List: OBJECT ORIENTATED PROGRAMMING THROUGH JAVA

No. of Hours per week: 2

External: 40

Internal: 10

Credits: 1

1. Write a program to read *Student Name, Regd.No, Marks [5]* and calculate Total, *Percentage, and Result*. Display all the details of students
2. Write a program to perform the following String Operations
 - a. Read a string
 - b. Find out whether there is a given substring or not
 - c. Compare existing string by another string and display status
 - d. Replace existing string character with another character
 - e. Count number of works in a string
3. Java program to implements Addition and Multiplication of two N X N matrices.
4. Java program to demonstrate the use of Constructor.
5. Calculate area of the following shapes using method overloading.
 - a. Triangle
 - b. Rectangle
 - c. Circle
 - d. Square
6. Implement inheritance between *Person (Aadhar, Surname, Name, DOB, and Age)* and *Student (Admission Number, College, Course, Year)* classes where ReadData(), Display Data() are overriding methods.
7. Java program on Multiple Inheritance.
8. Java program for to display *Serial Number from 1 to N* by creating two Threads
9. Java program to demonstrate the following exception handlings
 - a. Divided by Zero
 - b. Array Index Out of Bound
 - c. File Not Found
 - d. Arithmetic Exception
 - e. User Defined Exception
10. Write a program to create *Book (ISBN, Title, Author, Price, Pages, Publisher)* structure and store book details in a file and perform the following operations
 - a. Add book details
 - b. Search a book details for a given ISBN and display book details, if available
 - c. Update a book details using ISBN
 - d. Delete book details for a given ISBN and display list of remaining Books

A.G & S.G.SIDDHARTHA DEGREE COLLEGE OF ARTS & SCIENCE

Vuyyuru-521165. NAAC recredited at 'A' level

Autonomous -ISO 9001 – 2015 Certified

Title of the Paper: WEB TECHNOLOGY

Semester: VI

Course Code	CSC-601GE	Course Delivery Method	Class Room / Blended Mode – Both
Credits	3	CIA Marks	30
No. of Lecture Hours / Week	4	Semester End Exam Marks	70
Total Number of Lecture Hours	60	Total Marks	100
Year of Introduction :2017-18	Year of Offering: 2021 - 22	Year of Revision: ----	Percentage of Revision: 0%

Course Objectives:

To provide knowledge on web architecture, web services, client side and server side scripting technologies to focus on the development of web-based information systems and web services.

Course Outcomes:

CO ₁	Understand the basic structure of a HTML design and develop a website using different text Formatting tags, images, links, lists and tables.
CO ₂	Understand to style a webpage using CSS and Basic Concepts of Java Scripts
CO ₃	Understand to style a webpage Using Objects in Java Script and DHTML.
CO ₄	Understand the Basic Concepts of XML and Defining Data for Web Applications
CO ₅	Understand the Concepts of JS.

AG & SG SIDDHARTHA COLLEGE OF ARTS AND SCIENCES - VUYYURU.

An Autonomous college within the jurisdiction of Krishna University A.P, India.

(With Effect from Academic Year 2017-18)

COMPUTER SCIENCE	CSC-601(GE)	2021-'22	B.Sc.(MPCs & MCCs)
-------------------------	--------------------	-----------------	-------------------------------

SEMESTER – VI

PAPER – VII

Max. Marks 70

Syllabus

WEB TECHNOLOGIES

NO of Hours: 4

No of Credits: 3

Pass Marks 28

Course Objectives:

1. To provide knowledge on web architecture, web services, client side and server side scripting technologies to focus on the development of web-based information systems and web services.
2. To provide skills to design interactive and dynamic web sites.

Unit -I Introduction to XHTML:

12 Hrs

Introduction to HTML, Basic html, Document body text, Hyper links, Adding more formatting Lists, Tables, Images, Multimedia Objects, Frames, Forms and XHTML.

Unit- II: CSS:

12 Hrs

Cascading Style Sheets: Introduction, Defining your own styles, properties and values in styles, Formatting blocks of information, Layers.

Java Script: java Script, the basics, Variables, String Manipulations, Mathematical functions, Statements, Operators, Arrays, Functions.

Unit –III: Objects in Java Script & Dynamic HTML with Java Script 12 Hrs

Objects in Java Script: Data and objects in java script, Regular expressions, Exception Handling, Built in objects, Events.

Dynamic HTML with Java Script: Data validation, Opening a new window, Messages and Confirmations, The status bar, writing to a different frame, Rollover buttons, Moving images, multiple pages in a single download, A text-only menu system, Floating logos.

Unit –IV: XML Defining Data for Web Applications

12 Hrs

XML: Introduction to XML, Basic XML, document type definition, XML Schema, Document object model, presenting XML, Using XML parser.

UNIT-V: JSP:

10Hr's

JSP Lifecycle, Basic Syntax, EL (Expression Language), EL Syntax, Using EL Variables

Prescribed Books:

1. Chris Bates, Web Programming Building Internet Application, Second Edition, Wiley (2007)
2. Head First Servlet and JSP 2nd Edition, Bryan Basham, Kathy Sierra
3. Uttam Kumar Roy, Web Technologies from Oxford University Press

Student Activities:

1. Prepare a web site for your college
2. Prepare your personal website

AG & SG SIDDHARTHA COLLEGE OF ARTS AND SCIENCES - VUYURU.
An Autonomous college within the jurisdiction of Krishna University A.P, India.
(With Effect from Academic Year 2017-'18)

COMPUTER SCIENCE	CSC-601(GE)	2021-'22	B.Sc.(MPCs& MCCs)
-------------------------	--------------------	-----------------	------------------------------

SEMESTER – VI

PAPER – VII

Max. Marks 70

Model Paper

WEB TECHNOLOGIES

No of Hours: 4

No of Credits: 3

Pass Marks 28

Section -A

Answer **FOUR** Questions. Each Question carries **FIVE** Marks.

4 X 5=20M

1. Write about structure of HTML Document with an example
2. Explain about lists in HTML
3. Write about properties used in Style Sheet
4. Describe Data Object
5. Describe XML Elements
6. Write the syntax of EL and EL variables

Section- B

Answer **FIVE** the Questions. Each Question carries **TEN** Mark

5 X 10=50M

7. Explain about hyper links? Write about how to link another pages
8. What is Form? Explain about forms with examples
9. What is CSS? How to design Cascading style sheet
10. Explain about Mathematical Functions
11. Explain about Regular Expressions
12. Write about Data validations in DHTML
13. Explain about Document Object Model
14. Explain about JSP Lifecycle with neat diagram

AG & SG SIDDHARTHA COLLEGE OF ARTS AND SCIENCES - VUYYURU.
An Autonomous college within the jurisdiction of Krishna University A.P, India.
(With Effect from Academic Year 2017-'18)

COMPUTER SCIENCE	CSC-601(GE)	2021-22	B.Sc.(MPCs & MCCs)
SEMESTER – VI	PAPER – VII	Max. Marks 70	Pass Marks 28

Guidelines for paper setting '**WEB TECHNOLOGIES**'

Unit wise weight age of Marks

	Section-A (Short answer questions)	Section-B (essay questions)
Unit-1	2	2
Unit-2	2	2
Unit-3	2	2
Unit-4	1	1
Unit-5	1	1

- Each Short answer question carries 5 marks in Section –A
- Each Essay question carries 10 marks in Section –B
- The Question papers setters are requested to cover all the topics in the syllabus stipulated as per the weight age given by us

AG & SG SIDDHARTHA COLLEGE OF ARTS AND SCIENCES - VUYYURU.

An Autonomous college within the jurisdiction of Krishna University A.P, India.

(With Effect from Academic Year 2017-2018)

COMPUTER SCIENCE	CSC-601(GE)	2021-22	B.Sc.(MPCS & MCCs)
-------------------------	--------------------	----------------	-------------------------------

SEMESTER – VI

PAPER – VII

Max. Marks 50

Lab List

WEB TECHNOLOGIES

No. of Hours per week: 2

External: 25

Internal: 25

Credits: 2

1. Write an HTML program to demonstrate text formatting, working with images and hyper links
2. Write an HTML program to create Student Marks sheet preparation.
3. Write an HTML program to explain String manipulation-using functions.
4. Write an HTML program to explain <form> events
5. Write an HTML program to perform all arithmetic operations using java script.
6. Develop a HTML Form, which accepts any Mathematical expression. Write JavaScript code to Evaluates the expression and Displays the result.
7. Create a form for Student information. Write JavaScript code to find Total, Average, Result and Grade.
8. Create a form for Employee information. Write JavaScript code to find DA, HRA, PF, TAX, Gross pay, Deduction and Net pay.
9. Create a form consists of a Multiple choice questions that validates the answer dynamically and displaying result using java script.
10. Write a java script to work with following
 - a. Date display
 - b. Calendar
 - c. Copy Selected Text
 - b. IP Address

A.G & S.G.SIDDHARTHA DEGREE COLLEGE OF ARTS & SCIENCE

Vuyyuru-521165. NAAC reaccredited at 'A' level

Autonomous -ISO 9001 – 2015 Certified

Title of the Paper: PHP, MySql & WORDPRESS

Semester: IV

Course Code	CSC-602CE	Course Delivery Method	Class Room / Blended Mode – Both
Credits	3	CIA Marks	30
No. of Lecture Hours / Week	4	Semester End Exam Marks	70
Total Number of Lecture Hours	60	Total Marks	100
Year of Introduction :2017-18	Year of Offering: 2021 - 22	Year of Revision: ----	Percentage of Revision: 0%

Course Objectives:

To provide knowledge on web architecture, web services, client side and server side scripting technologies to focus on the development of web-based information systems and web services.

Course Outcomes:

CO ₁	Understand the concepts Of PHP and MY SQL Installations.
CO ₂	Able to know the basic concepts Function and Working with Functions.
CO ₃	Understand the concepts of FORMS and working with FORMS.
CO ₄	Understand the concepts of MY SQL and MY SQL Components.
CO ₅	Able to know the concepts of WORD PRESS.

AG & SG SIDDHARTHA COLLEGE OF ARTS AND SCIENCES - VUYYURU.
An Autonomous college within the jurisdiction of Krishna University A.P, India.
(With Effect from Academic Year 2017-2018)

COMPUTER SCIENCE	CSC-602CE	2021-'22	B.Sc.(MPCs& MCCs)
SEMESTER – VI	PAPER – VIII	Max. Marks 70	

Syllabus

PHP, MySql & Word Press

NO Of Hours:4

Credits: 3

Pass Marks 28

Course Objective: To introduce the concept of PHP and to give basic Knowledge of PHP. Learn about PHP Syntax., Arrays, PHP Loops, PHP and MySql connectivity, PHP form validation, PHP form handling. Overview of MySql and PHPMyAdmin, Understand basic concepts of how a database stores information via tables, Understanding of SQL syntax used with MySQL, Learn how to retrieve and manipulate data from one or more tables, Know how to filter data based upon multiple conditions, Updating and inserting data into existing tables, Learning how the relationships between tables will affect the SQL, The advantages of store procedures with storing data using variables and functions, How SQL can be used with programming languages like PHP to create dynamic websites for visitors, Review of some sample PHP projects interacting with MySql.

UNIT-1: Installing and Configuring MySQL:

10 Hrs

Current and Future Versions of MySQL, How to Get MySQL, Installing MySQL on Windows, Trouble Shooting your Installation, Basic Security Guidelines, Introducing MySQL Privilege System, Working with User Privileges. Installing and Configuring Apache: Current and future versions of Apache, Choosing the Appropriate Installation Method, Installing Apache on Windows, Apache Configuration File Structure, Apache Log Files, Apache Related Commands, Trouble Shooting. Installing and Configuring PHP: Building PHP with Apache on Windows, php.ini.Basics, The Basics of PHP scripts. The Building blocks of PHP: Variables, Data Types, Operators and Expressions, Constants. Flow Control Functions in PHP: Switching Flow, Loops, Code Blocks and Browser Output.

Unit – II: Working with Functions:

10 Hrs

What is function?, Calling functions, Defining Functions, Returning the values from User-Defined Functions, Variable Scope, Saving state between Function calls with the static statement, more about arguments. Working with Arrays: What are Arrays? Creating Arrays, Some Array-Related Functions. Working with Objects: Creating Objects, Object Instance Working with Strings, Dates and Time: Formatting strings with PHP, Investigating Strings with PHP, Manipulating Strings with PHP, Using Date and Time Functions in PHP.

Unit – III: Working with Forms:

15 Hrs

Creating Forms, Accessing Form Input with User defined Arrays, Combining HTML and PHP code on a single Page, Using Hidden Fields to save state, Redirecting the user, Sending Mail on Form Submission, Working with File Uploads. Working with Cookies and User Sessions: Introducing Cookies, Setting a Cookie with PHP, Session Function Overview, Starting a Session, Working with session variables, passing session IDs in the Query String, Destroying Sessions and Unsetting Variables, Using Sessions in an Environment with Registered Users. Working with Files and Directories: Including Files with include(), Validating Files, Creating and Deleting Files, Opening a File for Writing, Reading or Appending, Reading from Files, Writing or Appending to a File, Working with Directories.

Unit – IV: Introduction to MySQL**15Hrs**

Introduction to MySQL and Interfacing with Databases through PHP Understanding the database design process: The Importance of Good Database Design, Types of Table Relationships, Understanding Normalization. Learning basic SQL Commands: Learning the MySQL Data types, Learning the Table Creation Syntax, Using Insert Command, Using SELECT Command, Using WHERE in your Queries, Selecting from Multiple Tables, Using the UPDATE command to modify records, Using REPLACE Command, Using the DELETE Command, Frequently used string functions in MySQL, Using Date and Time Functions in MySQL. Interacting with MySQL using PHP: MySQL Versus MySQLi Functions, Connecting to MySQL with PHP, Working with MySQL Data.

Unit – V: Word press**10Hrs**

Word press: Introduction to word press, servers like wamp, bitnami e.tc, installing and configuring word press, understanding admin panel, working with posts and pages, using editor, text formatting with shortcuts, working with media-Adding, editing, deleting media elements, working with widgets, menus. Working with themes-parent and child themes, using featured images, configuring settings.

References:

1. Julie C. Meloni, PHP MySQL and Apache, SAMS Teach yourself, Pearson Education (2007).
2. Xue Bai Michael Ekedahl, The web warrior guide to Web Programming, Thomson (2006).

AG & SG SIDDHARTHA COLLEGE OF ARTS AND SCIENCES - VUYURU.
An Autonomous college within the jurisdiction of Krishna University A.P, India.
(With Effect from Academic Year 2017-'18)

COMPUTER SCIENCE	CSC-602CE	2021-'22	B.Sc.(MPCs)
-------------------------	------------------	-----------------	--------------------

SEMESTER – VI

PAPER – VIII

Max. Marks 70

Model Paper

PHP, MySql & Word Press

NO Of Hours:3

No Of Credits: 3

Pass Marks 28

Section- A

Answer FOUR Questions. Each Question carries FIVE Marks.

4*5=25M

- 1 .Define variable and list the standard data types in PHP.
2. What is Break and Continue statements in PHP.
3. Define Function and write a program for Function?
4. Write programs to pass an argument to function by Value and Reference in PHP.
5. What is Cookie and explain how to accessing cookie in PHP.
6. Write short notes on Word Press.

Section- B

Answer FIVE Questions. Each Question carries TEN Marks

5*10=50M

7. Explain about Operators and Expressions available in PHP with examples.
8. Explain about Loops and switching statements in PHP with examples.
9. Explain about Arrays and related functions to arrays in PHP with examples.
10. Explain the following Strings functions with examples
 - a. strlen() b. strstr() c. strpos() d. substr() e. strtok()
11. Explain how to send Mail on form submission in PHP.
12. Explain how to work with Sessions in PHP.
13. Explain how to insert & retrieve data with MySql in PHP.
14. Explain how to work with Themes and also featured images in Word Press

AG & SG SIDDHARTHA COLLEGE OF ARTS AND SCIENCES - VUYURU.

**An Autonomous college within the jurisdiction of Krishna University A.P, India.
(With Effect from Academic Year 2017-'18)**

COMPUTER SCIENCE	CSC-602CE	2021-'22	B.Sc.(MPCs,MCCs)
SEMESTER – VI	PAPER – VIII	Max. Marks 70	Pass Marks 28

Guidelines for paper setting **'PHP, MySql & Word Press '**

Unit wise weight age of Marks

	Section-A (Short answer questions)	Section-B (Essay questions)
Unit-1	2	2
Unit-2	2	2
Unit-3	2	2
Unit-4	1	1
Unit-5	1	1

- Each Short answer question carries 5 marks in Section –A
- Each Essay question carries 10 marks in Section –B
- The Question papers setters are requested to cover all the topics in the syllabus stipulated as per the weight age given by us.

AG & SG SIDDHARTHA COLLEGE OF ARTS AND SCIENCES - VUYYURU.

An Autonomous college within the jurisdiction of Krishna University A.P, India.

(With Effect from Academic Year 2017-2018)

COMPUTER SCIENCE	CSC-602CE	2021-'22	B.Sc.(MPCS&MCCS)
-------------------------	------------------	-----------------	-----------------------------

SEMESTER – VI

PAPER – VIII

Max. Marks 50

Lab List **PHP, MySql & Word Press Lab**

No. of Hours per week: 3

External: 25

Internal: 25

Credits: 2

MySQL Lab Cycle

Cycle -1

An Enterprise wishes to maintain the details about his suppliers and other corresponding details. For that he uses the following details.

Suppliers (sid: Integer, sname: string, address: string)

Parts (pid: Integer, pname: string, color: string)

Catalog (sid: integer, pid: integer, cost: real)

The catalog relation lists the prices charged for parts by suppliers.

Write the following queries in SQL:

1. Find the pnames of parts for which there is some supplier.
2. Find the snames of suppliers who supply every part.
3. Find the snames of supplier who supply every red part.
4. Find the pnames of parts supplied by London Supplier and by no one else.
5. Find the sid's of suppliers who charge more for some part than the average cost of that part.
6. For each part, find the sname of the supplier who charges the most for that part.
7. Find the sid's of suppliers who supply only red parts.
8. Find the sid's of suppliers who supply a red and a green part.
9. Find the sid's of suppliers who supply a red or green part.
10. Find the total amount has to pay for that supplier by part located from London.

Cycle – 2

An organisation wishes to maintain the status about the working hours made by his employees. For that he uses the following tables.

Emp (eid: integer, ename: string, age: integer, salary: real)

Works (eid: integer, did: integer, pct_time: integer)

Dept (did: integer, budget: real, managerid: integer)

An employee can work in more than one department; the pct_time field of the works relation shows the percentage of time that a given employee works in a given department.

Resolve the following queries.

1. Print the names and ages of each employee who works in both Hardware and Software departments.
2. For each department with more than 20 full time equivalent employees (i.e., where the part-time and full-time employees add up to at least that many full-time employees), print the did's together with the number of employees that work in that department.

3. Print the name of each employee whose salary exceeds the budget of all of the departments that he or she work in.
4. Find the managerid's of managers who manage only departments with budgets greater than 1,000,000.
5. Find the enames of managers who manage the departments with largest budget.
6. If a manager manages more than one department, he or she controls the sum of all the budgets for those departments. Find the managerid's of managers who control more than 5,000,000.
7. Find the managerid's of managers who control the highest amount.
8. Find the average manager salary.

PHP Lab Cycle

1. Write a PHP program to Display "Hello"
2. Write a PHP Program to display the today's date.
3. Write a PHP Program to read the employee details.
4. Write a PHP Program to display the
5. Write a PHP program to prepare the student marks list.
6. Write a PHP program to generate the multiplication of two matrices.
7. Write a PHP Application to perform demonstrate the college website.
8. Write a PHP application to add new Rows in a Table.
9. Write a PHP application to modify the Rows in a Table.
10. Write a PHP application to delete the Rows from a Table.
11. Write a PHP application to fetch the Rows in a Table.
12. Develop an PHP application to make following Operations
 - i. Registration of Users.
 - ii. Insert the details of the Users.
 - iii. Modify the Details.
 - iv. Transaction Maintenance.
 - a) No of times Logged in
 - b) Time Spent on each login.
 - c) Restrict the user for three trials only.
 - d) Delete the user if he spent more than 100 Hrs of transaction.

Wordpress Lab

1. Installation and configuration of word press.
2. Create a site and add a theme to it.

A.G & S.G.SIDDHARTHA DEGREE COLLEGE OF ARTS & SCIENCE

Vuyyuru-521165. NAAC reaccredited at 'A' level

Autonomous -ISO 9001 – 2015 Certified

Title of the Paper: JQUERY/AJAX/JSON/ANGULAR JS

Semester: VI

Course Code	CSC-603CE	Course Delivery Method	Class Room / Blended Mode – Both
Credits	3	CIA Marks	30
No. of Lecture Hours / Week	4	Semester End Exam Marks	70
Total Number of Lecture Hours	60	Total Marks	100
Year of Introduction :2017-18	Year of Offering: 2021 - 22	Year of Revision: ----	Percentage of Revision: 0%

Course Objectives:

To provide knowledge on web architecture, web services, client side and server side scripting technologies to focus on the development of web-based information systems and web services.

Course Outcomes:

CO ₁	Understand the concepts Of HTML and JQUERY
CO ₂	Understand the concepts JQUERY and CSS Methods using DOM Attributes
CO ₃	Understand the concepts of JQUERY USER INTERFACE Programs
CO ₄	Understand the concepts of AJAX and JSON Objects
CO ₅	Develop the ability to solve real-world problems through software development in high-level programming language like ANGULAR JS and ANIMATIONS

AG & SG SIDDHARTHA COLLEGE OF ARTS AND SCIENCES - VUYURU.
An Autonomous college within the jurisdiction of Krishna University A.P, India.
(With Effect from Academic Year 2017-2018)

COMPUTER SCIENCE	CSC-603CE	2021-'22	B.Sc.(MPCs,MCCs)
-------------------------	------------------	-----------------	-------------------------

SEMESTER – VI

PAPER – IX

Max. Marks 70

Syllabus Advanced java Script: JQUERY/AJAX/JSON/ANGULAR JS

NO Of Hours:4

Credits: 3

Pass Marks 28

Course Objective: To impart knowledge in designing a webpage in a structured way by using advanced java script ie., using different scripting languages

UNIT-1: JQuery – Basics:

10 Hrs

String, Numbers, Boolean, Objects, Arrays, Functions, Arguments, Scope, Built-in Functions. jQuerySelectors: CSS Element Selector, CSS Element ID Selector, CSS Element Class Selector, CSS Universal Selector, Multiple Elements E, F, G Selector, Callback Functions. jQuery – DOM Attributes: Get Attribute Value, Set Attribute Value. jQuery – DOM Traversing : Find Elements by index, Filtering out Elements, Locating Descendent Elements, JQuery DOM Traversing Methods.

Unit – II: jQuery – CSS Methods :

10 Hrs

Apply CSS Properties, Apply Multiple CSS Properties, Setting Element Width & Height, JQuery CSS Methods. jQuery – DOM Manipulation Methods: Content Manipulation, DOM Element Replacement, Removing DOM Elements, Inserting DOM elements, DOM Manipulation Methods. jQuery – Events Handling: Binding event handlers, Removing event handlers, Event Types, The Event Object, The Event Attributes. jQuery – Effects: JQuery Effect Methods, jQuery Hide and Show, jQuery Toggle, jQuery Slide – slideDown, slideUp, slideToggle, jQuery Fade – fadeIn, fadeOut, fadeTo, jQuery Custom Animations

Unit – III: Intro to jQuery UI

15 Hrs

, Need of jQuery UI in real web sites, Downloading jQuery UI, Importing jQuery UI, Draggable, Droppable, Resizable, Selectable, Sortable, Accordion, Auto Complete, Button Set, Date Picker, Dialog, Menu, Progress Bar, Slider, Spinner, Tabs, Tooltip, Color Animation, Easing Effects, addClass, removeClass, Effects, jQuery UI themes, Customizing jQuery UI widgets / plug-ins, jQuery UI with CDN, Consuming jQuery Plug-ins from 3rd party web sites jQuery Validations, Intro to jQuery validation plug-in, Using jQuery validation plug-in, Regular expressions.

Unit – IV: Intro to AJAX

15 Hrs

Need of AJAX in real web sites, Getting database data using jQueryAJAX, Inserting, Updating, Deleting database data using jQuery-AJAX Grid Development using jQuery-AJAX Intro to JSON JSON syntax, Need of JSON in real web sites, JSON object, JSON array, Complex JSON objects, Reading JSON objects using jQuery.

Unit – V: Intro to AngularJS

15 Hrs

Need of AngularJS in real web sites, Downloading AngularJS, AngularJS first example, AngularJS built-in directives, AngularJS expressions, AngularJS modules, AngularJS controllers, AngularJS scope AngularJS dependency injection AngularJS, bootstrapping AngularJS data bindings, AngularJS \$watch, AngularJS filters, AngularJS events, AngularJS AJAX, Ng-repeat, AngularJS with json arrays, AngularJS registration form and login form, AngularJS CRUD operations, AngularJS Animations, AngularJS validations AngularJS \$q, AngularJS custom values, AngularJS custom factories, AngularJS custom services, AngularJS custom directives, AngularJS custom providers, AngularJS Routing, AngularUI Routing.

References:

1. jQuery UI 1.8: The User Interface Library for jQuery by Dan Wellman
2. jQuery Fundamentals by Rebecca Murphey
3. Ajax: The Complete Reference by Thomas

AG & SG SIDDHARTHA COLLEGE OF ARTS AND SCIENCES - VUYYURU.
An Autonomous college within the jurisdiction of Krishna University A.P, India.
(With Effect from Academic Year 2017-'18)

COMPUTER SCIENCE	CSC-603CE	2021-'22	B.Sc.(MPCs,MCCs)
-------------------------	------------------	-----------------	-------------------------

SEMESTER – VI

PAPER – IX

Max. Marks 70

Model Paper Advanced java Script: JQUERY/AJAX/JSON/ANGULAR JS

NO of Hours: 3

No Of Credits: 3

Pass Marks 28

Section- A

Answer FOUR Questions. Each Question carries FIVE Marks.

4*5=20M

1. What is jquery? Write a simple program to display welcome message.
2. Write a jquery-dom attributes.
3. Write a program for jquery fade in, fade out.
4. Discuss in detail about jquery UI categorization.
5. Write a need of AJAX in real websites..
6. Write a short notes angularJS built-in directives.

Section- B

Answer FIVE Questions. Each Question carries TEN Marks

5*10=50M

7. Explain in detail about DOM traversing methods.
8. Explain detail about jquery-dom manipulation methods.
9. Explain detail about jquery even handling methods.
10. Write a program for droppable, resizable using jquery UI.
11. How can we manipulate the data in a database using jquery-AJAX?
12. What is JSON object? Discuss in detail about complex JSON objects.
13. What is angular JS? Need of angular JS in real websites & write any example program.
14. Write a program for registration from and login from using Angular JS.

AG & SG SIDDHARTHA COLLEGE OF ARTS AND SCIENCES - VUYYURU.
An Autonomous college within the jurisdiction of Krishna University A.P, India.
(With Effect from Academic Year 2017-'18)

COMPUTER SCIENCE	CSC-603CE	2021-'22	B.Sc.(MPCs)
------------------	-----------	----------	-------------

SEMESTER – VI PAPER – IX Max. Marks 70 Pass Marks: 28

Guidelines for paper setting ‘ **Advanced java Script: JQUERY/AJAX/JSON/ANGULAR JS**’

Unit wise weightage of Marks

	Section-A (Short answer questions)	Section-B (Essay questions)
Unit-1	2	1
Unit-2	2	2
Unit-3	1	1
Unit-4	2	2
Unit-5	1	2

- Each Short answer question carries 5 marks in Section –A
- Each Essay question carries 10 marks in Section –B
- The Question papers setters are requested to cover all the topics in the syllabus stipulated as per the weightage given by us.

AG & SG SIDDHARTHA COLLEGE OF ARTS AND SCIENCES - VUYYURU.

An Autonomous college within the jurisdiction of Krishna University A.P, India.

(With Effect from Academic Year 2017-2018)

COMPUTER SCIENCE	CSC-603CE	2021-'22	B.Sc.(MPCS&MCCs)
-------------------------	------------------	-----------------	-----------------------------

SEMESTER – VI

PAPER – IX

Max. Marks 50

Lab List Advanced java Script: JQUERY/AJAX/JSON/ANGULAR JS

No. of Hours per week: 3

External: 25

Internal: 25

Credits:2

1. Using jQuery find all textareas, and makes a border. Then adds all paragraphs to the jQuery object to set their borders red.
2. Using jQuery add the class "w3r_font_color" and w3r_background to the last paragraph element.
3. Using jQuery add a new class to an element that already has a class.
4. Using jQuery insert some HTML after all paragraphs.
5. Using jQuery insert a DOM element after all paragraphs.
6. Convert three headers and content panels into an accordion. Initialize the accordion
And specify the animate option
7. Convert three headers and content panels into an accordion. Initialize the accordion and specify the height.
8. Create a pre-populated list of values and delay in milliseconds between a keystroke occurs and a search is performed.
9. Initialize the button and specify the disable option.
10. Initialize the button and specify an icon on the button.
11. Initialize the button and do not show the label.
12. Create a simple jQuery UI Datepicker. Now pick a date and store it in a textbox.
13. Initialize the date picker and specify a text to display for the week of the year column heading.

A.G & S.G.SIDDHARTHA DEGREE COLLEGE OF ARTS & SCIENCE

Vuyyuru-521165. NAAC reaccredited at 'A' level

Autonomous -ISO 9001 – 2015 Certified

Title of the Paper: PROJECT (Java, PHP & MYSQL) Semester: VI

Course Code	CSC-604GE	Course Delivery Method	Class Room / Blended Mode – Both
Credits	3	CIA Marks	30
No. of Lecture Hours / Week	4	Semester End Exam Marks	70
Total Number of Lecture Hours	60	Total Marks	100
Year of Introduction :2017-18	Year of Offering: 2021 - 22	Year of Revision: ----	Percentage of Revision: 0%

Course Objectives:

To provide knowledge on web architecture, web services, client side and server side scripting technologies to focus on the development of web-based information systems and web services.

AG & SG SIDDHARTHA COLLEGE OF ARTS AND SCIENCES - VUYYURU.
An Autonomous college within the jurisdiction of Krishna University A.P, India.
(With Effect from Academic Year 2017-'18)

COMPUTER SCIENCE	CSC PROJ-602 P	2021-'22	B.Sc.(MPCs,MCCs)
-------------------------	-----------------------	-----------------	-------------------------

SEMESTER – VI **PROJECT (Java, PHP & MYSQL)** **Max. Marks 100**

OBJECTIVE

The objective of the Project Course is to help the students to study, analyze and design software or utility for different problems or applications. This will improve the skills of software development of the students.

MARKS FOR PROJECT EVALUATION

The project course will be evaluated for **100** Marks, of which **75** marks are meant for the practical evaluation of a project and **25** marks are allotted for attending viva-voce examination. The passing minimum in the project work will be **50%** of the total mark. i.e. the student should get minimum **50%** marks in the project evaluation and the viva-voce examination. Thus, the minimum mark the student is required to obtain is 50 out of 100 marks.

A.G & S.G.SIDDHARTHA DEGREE COLLEGE OF ARTS & SCIENCE

Vuyyuru-521165. NAAC reaccredited at 'A' level

Autonomous -ISO 9001 – 2015 Certified

Title of the Paper: TALLY

Semester: VI

Course Code	CSC-605CE	Course Delivery Method	Class Room / Blended Mode – Both
Credits	3	CIA Marks	30
No. of Lecture Hours / Week	4	Semester End Exam Marks	70
Total Number of Lecture Hours	60	Total Marks	100
Year of Introduction :2017-18	Year of Offering: 2021 - 22	Year of Revision: ----	Percentage of Revision: 0%

Course Objectives:

To provide knowledge on web architecture, web services, client side and server side scripting technologies to focus on the development of web-based information systems and web services.

Course Outcomes:

CO ₁	Able to understand the basic concepts of TALLY
CO ₂	Able to understand the installation of TALLY Software.
CO ₃	Able to implement the concepts of ledgers
CO ₄	Able to implement the concepts of vouchers
CO ₅	Able to implement the basic concepts of final accounts

AG & SG SIDDHARTHA COLLEGE OF ARTS AND SCIENCES - VUYURU.
An Autonomous college within the jurisdiction of Krishna University A.P, India.
(With Effect from Academic Year 2017-2018)

COMPUTER SCIENCE	CCSC-605CE	2021-22	B.Com (C.A)
-------------------------	-------------------	----------------	--------------------

SEMESTER –VI **PAPER – IX** **Total: 60 Hrs**

Syllabus **TALLY** **Max.Marks:70**

Credits 3 **NO Of Hours 5** **Pass Marks 28**
Unit-I: Introduction to Tally: **12Hrs**

Introduction, Software versions of Tally, Terminology related to Accounts credit & Debit, Journal, Ledger, Voucher, Group etc. Difference between Manual Accounting and Accounting Packages. Features and advantages of Tally.

Unit-II: Introduction of Tally Software **12Hrs**

Introduction of Tally Software Creation of a company, Gateway of Tally, Accounts Information, Groups, pre defined Groups, Creation of New Groups, and Creation of sub Group.

Unit-III: Ledgers **12Hrs**

Ledger Creation Single and multiple Ledgers, Displaying & altering Ledgers, configure Ledger, Stock Ledger, Ledgers and their Group Allocation.

Unit-IV: Vouchers **12Hrs**

Types of vouchers – recording of vouchers – entry of payment voucher, Receipt voucher, sales voucher, purchase voucher, Journal Voucher, Contra Voucher, Debit & Credit Note. Creating New Voucher types, customizing the Existing voucher types, Alternation of Voucher, Deletion of Voucher.

Unit-V: Final Accounts **12Hrs**

Customizing the final accounts – Profit and Loss Account, Balance Sheet. Key board shortcuts in Tally. Generating the Reports from Tally, Trial Balance, Account Books, Sales, Purchase, Journal Registers, Statement of Accounts, Day Book, List of Accounts.

Reference Books:

1. K. Kiran Kumar, Tally ERP9.
2. Tally 9 In Simple Steps, Kogent solutions Inc., John Wiley & Sons, 2008.
3. Narmata Agarwal, Financial Accounting on Computers Using Tally, Dreamtech Press, 2000.
4. Tally 9.0, Google eBook, Computer World.
5. Vikas Gupta, Comdex Computer and Financial Accounting with Tally 9.0, 2007.

AG & SG SIDDHARTHA COLLEGE OF ARTS AND SCIENCES - VUYURU.

An Autonomous college within the jurisdiction of Krishna University A.P, India.

(With Effect from Academic Year 2017-2018)

COMPUTER SCIENCE	CCSC-605CE	2021-22	B.Com (C.A)
-------------------------	-------------------	----------------	--------------------

SEMESTER –VI

PAPER – IX

Total: 60 Hrs

Model Paper

TALLY

Max.Marks:70

Credits 3

NO Of Hours 5

Pass Marks: 28

Answer **FIVE** Questions. Each Question carries **FIVE** Marks.

5x5=25M

1. Differentiate between Manual Accounting and Accounting Packages?
2. What are the features of Tally?
3. How to maintain account information? Explain
4. Explain how to create a stock ledger?
5. Explain contra Voucher
6. Write a short note on Day Book

Section- B

Answer **FIVE** the Questions. Each Question carries **TEN** Marks

5 X 10=50M

7. Explain evolution of Tally and what are the features and advantages of Tally
8. Explain versions of Tally software
9. Explain about Gateway of Tally
10. Explain about Group and predefined Groups
11. Explain ledger creation
12. How to create a single and multiple ledgers
13. Explain different types of vouchers?
14. Explain how to generate the reports from Tally?

AG & SG SIDDHARTHA COLLEGE OF ARTS AND SCIENCES - VUYYURU.
An Autonomous college within the jurisdiction of Krishna University A.P, India.
(With Effect From Academic Year 2017-'18)

COMPUTER SCIENCE	CCSC-605CE	2021-22	B.Com (C.A)
-------------------------	-------------------	----------------	--------------------

SEMESTER –VI **PAPER – IX** **Max. Marks 70** **Pass Marks 28**

Guidelines for paper setting '**TALLY**'

Unit wise weight age of Marks

	Section-A (Short answer questions)	Section-B (essay questions)
Unit-1	2	2
Unit-2	2	2
Unit-3	2	2
Unit-4	1	1
Unit-5	1	1

- Each Short answer question carries 5 marks in Section –A
- Each Essay question carries 10 marks in Section –B
- The Question papers setters are requested to cover all the topics in the syllabus stipulated as per the weightage given by us

AG & SG SIDDHARTHA COLLEGE OF ARTS AND SCIENCES - VUYURU.
An Autonomous college within the jurisdiction of Krishna University A.P, India.
(With Effect From Academic Year 2017-'18)

COMPUTER SCIENCE	CCSC-605P	2021-22	B.Com.(C.A.)
-------------------------	------------------	----------------	---------------------

SEMESTER – VI

PAPER – V

Max. Marks:50
Pass Mark: 20

TALLY

No. Of Hours per week: 3

External: 25

Internal: 25

Credits: 2

Lab list

1. Architecture and customization of Tally
2. Configuration of Tally
3. Tally Screens and Menus
4. Creation of new company and groups.
5. Preparation of voucher entries.
 - a. Payment voucher creation
 - b. Receipt voucher creation
 - c. Sales voucher creation
 - d. Purchase voucher creation
 - e. Contra voucher creation
 - f. Journal voucher creation
6. Ledger Creation.
7. Preparation of VAT
8. Preparation of TDS
7. Preparation of Trail balance
8. Preparation of Profit and loss statement.
9. Preparation of Balance Sheet
10. Preparation of Bank Reconciliation Statement.
11. Example Exercise

A.G & S.G.SIDDHARTHA DEGREE COLLEGE OF ARTS & SCIENCE

Vuyyuru-521165. NAAC reaccredited at 'A' level

Autonomous -ISO 9001 – 2015 Certified

Title of the Paper: E-COMMERCE

Semester: VI

Course Code	CSC-606CE	Course Delivery Method	Class Room / Blended Mode – Both
Credits	3	CIA Marks	30
No. of Lecture Hours / Week	4	Semester End Exam Marks	70
Total Number of Lecture Hours	60	Total Marks	100
Year of Introduction :2017-18	Year of Offering: 2021 - 22	Year of Revision: ----	Percentage of Revision: 0%

Course Objectives:

To provide knowledge on web architecture, web services, client side and server side scripting technologies to focus on the development of web-based information systems and web services.

Course Outcomes:

CO ₁	Understand the benefits of a well-structured program
CO ₂	Understand different computer programming paradigms
CO ₃	Understand underlying principles of Object-Oriented Programming in Java
CO ₄	Develop problem-solving and programming skills using OOP concepts
CO ₅	Develop the ability to solve real-world problems through software development in high-level programming language like Java

AG & SG SIDDHARTHA COLLEGE OF ARTS AND SCIENCES – VUYYURU.
An Autonomous college within the jurisdiction of Krishna University A.P, India.
(With Effect From Academic Year 2017-2018)

COMPUTER SCIENCE	CCSC-606CE	2021-22	B.Com (C.A)
-------------------------	-------------------	----------------	--------------------

SEMESTER –VI

PAPER – X

Total: 60 Hrs

Syllabus

E-COMMERCE

Max.Marks:70

Credits 3

NO Of Hours 5

Pass Marks 28

Unit-I: Introduction to E-Commerce

Scope, Definition, e-Commerce and the Trade Cycle, Electronic Markets, Electronic Data Interchange, Internet Commerce. Business Strategy in an Electronic Age: Supply Chains, Porter's Value Chain Model, Inter Organizational Value Chains, Competitive Strategy, First Mover Advantage – Sustainable Competitive Advantage, Competitive Advantage using E-Commerce – Business Strategy.

Unit-II: Business-to-Business Electronic Commerce

Characteristics of B2B EC, Models of B2B EC, Procurement Management by using the Buyer's Internal Market place, Just in Time Delivery, Other B2B Models, Auctions and Services from traditional to Internet Based EDI, Integration with Back-end Information System, Role of Software Agents for B2B EC, Electronic marketing in B2B, Solutions of B2B EC, Managerial Issues, Electronic Data Interchange (EDI), EDI: Nuts and Bolts EDI and Business.

Unit-III: Internet and Extranet

Automotive Network Exchange, Largest Extranet, Architecture of the Internet, Intranet and Extranet, Intranet software, Applications of Intranets, intranet Application Case Studies, Considerations in Intranet Deployment, Extranets, Structures of Extranets, Extranet products and services, Applications of Extranets, Business Models of Extranet Applications, Managerial Issues. Electronic Payment Systems: Issues and Challenges .

Unit-IV: Public Policy:

From Legal Issues to Privacy : Legal Incidents, Ethical and Other public Policy Issues, Protecting Privacy, Protecting Intellectual Property, Free speech, Internet Indecency and Censorship, Taxation and Encryption Policies, Other Legal Issues: Contracts, Gambling and More, Consumer and Seller Protection in EC.

Unit-V: Infrastructure For EC

Network of Networks, Internet Protocols, Web- Based client/Server, Internet Security, Selling on the Web, Chatting on the Web, Multimedia delivery, Analyzing Web Visits, Managerial Issues, Equipment required for establishing EC Sites – problems in Operation – Future of EC.

Reference Books

1. David Whiteley, "E-Commerce", Tata McGraw Hill, 2000.
2. E Business by Parag Kulakarni and Sunitha Jahirabadkar from Oxford University Press.
3. E Business by Jonathan Reynolds from Oxford University Press.
4. Eframi Turban, Jae Lee, David King, K. Michael Chung, "Electronic Commerce",
5. Pearson Education, 2000.

AG & SG SIDDHARTHA COLLEGE OF ARTS AND SCIENCES – VUYYURU.

An Autonomous college within the jurisdiction of Krishna University A.P, India.

(With Effect From Academic Year 2017-2018)

COMPUTER SCIENCE	CCSC-606CE	2021-22	B.Com (C.A)
-------------------------	-------------------	----------------	--------------------

SEMESTER –VI

PAPER – X

Total: 60 Hrs

Syllabus

E-COMMERCE

Max.Marks:70

Credits 3

NO Of Hours5

Pass Marks 28

Section-A

Answer **FIVE** Questions. Each Question carries **FIVE** Marks.

5*5=25M

1. Explain Electronic data interchange?
2. Write about Value Chain Model
3. What are the characteristics of B2B Electronic Commerce
4. Write about applications of Intranet?
5. Explain encryption policies?
6. Write about Internet protocols?

Section-B

Answer **FIVE** Questions. Each Question carries **TEN** Marks.

5*10=50M

7. What are the advantages and limitations of E-commerce?
8. Write Business Strategy in an Electronic age
9. Explain Electronic Data Interchange(EDI)
10. Explain different Models of B2B Electronic Commerce?
11. Explain the Architecture of Internet?
12. Explain Business Models of Extranet Applications?
13. Explain Ethical and Other public Policy Issues?
14. Explain about the future of EC

AG & SG SIDDHARTHA COLLEGE OF ARTS AND SCIENCES – VUYYURU.

An Autonomous college within the jurisdiction of Krishna University A.P, India.
(With Effect From Academic Year 2017-2018)

COMPUTER SCIENCE	CCSC-606CE	2021-22	B.Com (C.A)
------------------	------------	---------	-------------

SEMESTER –VI

PAPER – X

Max. Marks 70

Pass Marks 28

Guidelines for paper setting '**E-COMMERCE**'

Unit wise weight age of Marks

	Section-A (Short answer questions)	Section-B (essay questions)
Unit-1	2	2
Unit-2	2	2
Unit-3	2	2
Unit-4	1	1
Unit-5	1	1

- Each Short answer question carries 5 marks in Section –A
- Each Essay question carries 10 marks in Section –B
- The Question papers setters are requested to cover all the topics in the syllabus stipulated as per the weight age given by us

A.G & S.G.SIDDHARTHA DEGREE COLLEGE OF ARTS & SCIENCE

Vuyyuru-521165. NAAC reaccredited at 'A' level

Autonomous -ISO 9001 – 2015 Certified

Title of the Paper: PHP & MySql

Semester: IV

Course Code	CSC-607CE	Course Delivery Method	Class Room / Blended Mode – Both
Credits	3	CIA Marks	30
No. of Lecture Hours / Week	4	Semester End Exam Marks	70
Total Number of Lecture Hours	60	Total Marks	100
Year of Introduction :2017-18	Year of Offering: 2021 - 22	Year of Revision: ----	Percentage of Revision: 0%

Course Objectives:

To provide knowledge on web architecture, web services, client side and server side scripting technologies to focus on the development of web-based information systems and web services.

Course Outcomes:

CO ₁	Understand the benefits of a well-structured program
CO ₂	Understand different computer programming paradigms
CO ₃	Understand underlying principles of Object-Oriented Programming in Java
CO ₄	Develop problem-solving and programming skills using OOP concepts
CO ₅	Develop the ability to solve real-world problems through software development in high-level programming language like Java

AG & SG SIDDHARTHA COLLEGE OF ARTS AND SCIENCES – VUYURU.
An Autonomous college within the jurisdiction of Krishna University A.P, India.
(With Effect From Academic Year 2017-'18)

COMPUTER SCIENCE	CCSC-607CE	2021-22	B.Com (C.A)
-------------------------	-------------------	----------------	--------------------

SEMESTER –VI

PAPER – XI

Syllabus

PHP& MY SQL

Max.Marks:70

Credits 3

NO Of Hours 5

Pass Marks 28

Unit-I: Building blocks of PHP:

Variables, Data Types, Operators and Expressions, Constants. Flow Control Functions in PHP: Switching Flow, Loops, Code Blocks and Browser Output. Working with Functions: Defining Functions, Calling functions, returning the values from UserDefined Functions, Variable Scope, Saving State between Function calls with the Static statement, more about arguments.

Unit-II: Working with Arrays:

Arrays, Creating Arrays, Some Array-Related Functions. Working with Objects: Creating Objects, Object Instance. Working with Strings, Dates and Time: Formatting Strings with PHP, Investigating Strings with PHP, Manipulating Strings with PHP, Using Date and Time Functions in PHP.

Unit-III: Working with Forms:

Creating Forms, Accessing Form – Input with User defined Arrays, Combining HTML and PHP code on a single Page, Using Hidden Fields to save state, Redirecting the user, Sending Mail on Form Submission, Working with File Uploads. Working with Cookies and User Sessions: Introducing Cookies, Setting a Cookie with PHP, Session Function Overview, Starting a Session, Working with session variables, passing session Ids in the Query String, Destroying Sessions and Unsetting Variables, Using Sessions in an Environment with Registered Users.

Unit-IV: Working with Files and Directories:

Including Files with include(), Validating Files, Creating and Deleting Files, Opening a File for Writing, Reading or Appending, Reading from Files, Writing or Appending to a File, Working with Directories, Open Pipes to and from Process Using popen (), Running Commands with exec(), Running Commands with system () or passthru (). Working with Images: Understanding the Image-Creation Process, Necessary Modifications to PHP, Drawing a New Image, Getting Fancy with Pie Charts, Modifying Existing Images, Image Creation from User Input.

Unit-V: Interacting with MySQL using PHP:

MySQL Versus MySQLi Functions, Connecting to MySQL with PHP, Working with MySQL Data. Creating an Online Address Book: Planning and Creating Database Tables, Creating Menu, Creating Record Addition Mechanism, Viewing Records, Creating the Record Deletion Mechanism, Adding Sub-entities to a Record.

References:

1. Julie C. Meloni, PHP MySQL and Apache, SAMS Teach Yourself, Pearson Education (2007).
2. Xue Bai Michael Ekedahl, The Web Warrior Guide to Web Programming, Thomson (2006).

AG & SG SIDDHARTHA COLLEGE OF ARTS AND SCIENCES – VUYYURU.

An Autonomous college within the jurisdiction of Krishna University A.P, India.

(With Effect From Academic Year 2017-2018)

COMPUTER SCIENCE	CCSC-607CE	2021-22	B.Com (C.A)
-------------------------	-------------------	----------------	--------------------

SEMESTER –VI

PAPER – XI

Total: 60

Hrs

Syllabus

PHP & MYSQL

Max.Marks:70

Credits 3

NO Of Hours 5

Pass Marks 28

Section-A

Answer **FIVE** Questions. Each Question carries **FIVE** Marks.

5*5=25M

1. Explain about different data types available in PHP?
2. Define function? Explain how to call the function?
3. Write a short note on Creating Objects
4. Explain about date and time functions?
5. Explain about cookies?
6. Describe how to create the Record Addition Mechanism?

Section-B

Answer **FIVE** Questions. Each Question carries **TEN** Marks.

5*10=50M

7. Explain different types of Operators in PHP?
8. Explain flow control functions in PHP?
9. What is an Array? Explain about array related functions.
10. Explain different string functions in PHP?
11. Explain about how to create and access a form in PHP?
12. Describe the working with session variables?
13. Explain working with Directories?
14. Explain about how to insert and retrieve the data in PHP?

AG & SG SIDDHARTHA COLLEGE OF ARTS AND SCIENCES – VUYYURU.
An Autonomous college within the jurisdiction of Krishna University A.P, India.
(With Effect from Academic Year 2017-2018)

Computer Science	CCSC-607CE	2021-22	B.Com (C.A)
------------------	------------	---------	-------------

SEMESTER –VI

PAPER – XI

Max. Marks 70

Pass Marks 28

Guidelines for paper setting '**PHP & MYSQL**'

Unit wise weight age of Marks

	Section-A (Short answer questions)	Section-B (essay questions)
Unit-1	2	2
Unit-2	2	2
Unit-3	2	2
Unit-4	1	1
Unit-5	1	1

- Each Short answer question carries 5 marks in Section –A
- Each Essay question carries 10 marks in Section –B
- The Question papers setters are requested to cover all the topics in the syllabus stipulated as per the weight age given by

AG & SG SIDDHARTHA COLLEGE OF ARTS AND SCIENCES - VUYYURU.

An Autonomous college within the jurisdiction of Krishna University A.P, India.

(With Effect from Academic Year 2017-2018)

COMPUTER SCIENCE	CCSC-607CE	2021-22	B.Com (C.A)
-------------------------	-------------------	----------------	--------------------

SEMESTER –VI

PAPER – VI

Total: 60 Hrs

Lab List PHP, MySQL

Pass Marks 20

No. of Hours per week: 2

External: 25

Internal: 25

Credits: 2

MySQL Lab Cycle

Cycle -1

An Enterprise wishes to maintain the details about his suppliers and other corresponding details. For that he uses the following details.

Suppliers (sid: Integer, sname: string, address: string)

Parts (pid: Integer, pname: string, color: string)

Catalog (sid: integer, pid: integer, cost: real)

The catalog relation lists the prices charged for parts by suppliers.

Write the following queries in SQL:

1. Find the pnames of parts for which there is some supplier.
2. Find the snames of suppliers who supply every part.
3. Find the snames of supplier who supply every red part.
4. Find the pnames of parts supplied by London Supplier and by no one else.
5. Find the sid's of suppliers who charge more for some part than the average cost of that part.
6. For each part, find the sname of the supplier who charges the most for that part.
7. Find the sid's of suppliers who supply only red parts.
8. Find the sid's of suppliers who supply a red and a green part.
9. Find the sid's of suppliers who supply a red or green part.
10. Find the total amount has to pay for that supplier by part located from London.

Cycle – 2

An organisation wishes to maintain the status about the working hours made by his employees. For that he uses the following tables.

Emp (eid: integer, ename: string, age: integer, salary: real)

Works (eid: integer, did: integer, pct_time: integer)

Dept (did: integer, budget: real, managerid: integer)

An employee can work in more than one department; the pct_time field of the works relation shows the percentage of time that a given employee works in a given department.

Resolve the following queries.

1. Print the names and ages of each employee who works in both Hardware and Software departments.

2. For each department with more than 20 full time equivalent employees (i.e., where the part-time and full-time employees add up to at least that many full-time employees), print the did's together with the number of employees that work in that department.
3. Print the name of each employee whose salary exceeds the budget of all of the departments that he or she work in.
4. Find the managerid's of managers who manage only departments with budgets greater than 1,000,000.
5. Find the enames of managers who manage the departments with largest budget.
6. If a manager manages more than one department, he or she controls the sum of all the budgets for those departments. Find the managerid's of managers who control more than 5,000,000.
7. Find the managerid's of managers who control the highest amount.
8. Find the average manager salary.

PHP Lab Cycle

1. Write a PHP program to Display "Hello"
2. Write a PHP Program to display the today's date.
3. Write a PHP Program to read the employee details.
4. Write a PHP program to prepare the student marks list.
5. Write a PHP program to generate the multiplication of two matrices.
6. Write a PHP Application to perform demonstrate the college website.
7. Write a PHP application to add new Rows in a Table.
8. Write a PHP application to modify the Rows in a Table.
9. Write a PHP application to delete the Rows from a Table.
10. Write a PHP application to fetch the Rows in a Table.
11. Develop an PHP application to make following Operations
 - i. Registration of Users.
 - ii. Insert the details of the Users.
 - iii. Modify the Details.
 - iv. Transaction Maintenance.
 - a) No of times Logged in
 - b) Time Spent on each login.
 - c) Restrict the user for three trials only.
 - d) Delete the user if he spent more than 100 Hrs of transaction.

**A.G& S.G.SIDDHARTHA DEGREE COLLEGE OF ARTS &
SCIENCE**

VUYYURU-521165, KRISHNA Dt., A.P.(Autonomous)

Accredited by NAAC with "A" Grade

2021-2022



DEPARTMENT OF COMMERCE

MINUTES OF BOARD OF STUDIES

ODD SEMESTER

29-10-2021

10.30 A.M on 29-10-2021 through CiscoWebex Meeting

Dr. K.Venkateswarlu ... Presiding

Members Present:

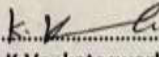
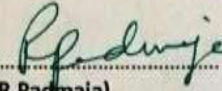
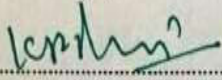
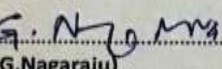
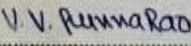
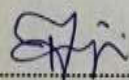
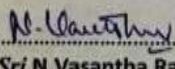
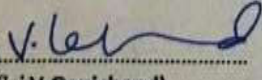
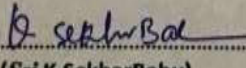
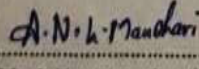
- 1)  Chairman Head, Department of Commerce
(Dr.K.Venkateswarlu) AG & SG S Degree College of Arts & Science
Vuyyuru
- 2)  University Asst. Professor
(Dr.R.Padmaja) Nominee Krishna University
Machilipatnam
- 3)  Subject expert Lecturer in Commerce,
(Dr.K.Peddiraju) Govt. Degree College
Razole
- 4)  Subject expert Lecturer in Commerce
(Dr.G.Nagaraju) Acharya Nagarjuna University
Guntur.
- 5)  Member General Manager
(Sri V.Punna Rao) K.C.P & IC Ltd
Vuyyuru.
- 6)  Member Chartered Accountant
(Sri V.Balaji) Managing Partner
Balaji V & Co
Vuyyuru
- 7)  Member Ad-hoc Lecturer in Commerce
(Sri N.Vasantha Rao) AG & SG S Degree College of Arts & Science
Vuyyuru
- 8)  Member Ad-hoc Lecturer in Commerce
(Sri V.Gopichand) AG & SG S Degree College of Arts & Science
Vuyyuru
- 9)  Member Ad-hoc Lecturer in Commerce
(Sri K.Sekhar Babu) AG & SG S Degree College of Arts & Science
Vuyyuru
- 10)  Member Ad-hoc Lecturer in Commerce
(Ms A.N.L Manohari) AG & SG S Degree College of Arts & Science
Vuyyuru

Agenda of B.O.S Meeting:

1. To discuss and recommend the Syllabi, Model Question Papers and Guidelines to be followed by question paper setters in Commerce for the 1st Semester as per the guidelines and instruction under CBCS prescribed by APSCHE for the Academic Year 2021-22.
2. To discuss and recommend the Syllabi, Model Question Papers and Guidelines to be followed by question paper setters in Commerce for the 3rd Semester as per the guidelines and instructions under CBCS prescribed by APSCHE for the Academic Year 2021-2022.
3. To discuss and recommend the Syllabi, Model Question Papers and Guidelines to be followed by question paper setters in Commerce for the 5th Semester as per the guidelines and instructions under CBCS prescribed by Krishna University for the Academic Year 2021-2022.
4. To recommend the Blue print of I, III & V Semesters of B.Com (General & Computers) for the Academic Year 2021-2022.
5. To recommend the Teaching and Evaluation methods to be followed under CBCS
6. Any other suggestions regarding Certificate Course, Seminars, Workshops, Guest Lectures to be organized.
7. Any other matter.

RESOLUTIONS

1. Discussed and recommended Continue the same syllabi, Model Question Papers and Guidelines for Question paper setters in commerce for the 1st Semester of **I B.Com., (General& Computer& e-Commerce)** for the Academic year 2021-2022. Prescribed by **APSCHE**
2. Discussed and recommended the Changed syllabi, Model Question Papers and Guidelines for question paper setters in Commerce for the 3rd Semester of **II B.Com.,(General& Computer)** for the Academic year 2021-2022. prescribed by **APSCHE**. In Business Statistics “**Diagrams and Graphic Presentation of data**” was deleted in Unit I. In Unit III “**Skeweness and Measures of Skeweness**” Introduced and A Topic Named “**Kurtosis**” was deleted. In Unit IV Two New Topics “**Analysis of Time series & Index Numbers**” Introduced.
3. Discussed and recommended that no changes are required in syllabi, but some minor changes are required in Model Question Papers and Guidelines for question paper setters in Commerce for the 5th Semester of **III B.Com., (general & computer)** for the Academic year 2021-2022.
4. It is resolved to continue the same blue prints of III. & V Semesters of Degree B.Com (**general & computer**) for the Academic year 2021-2022.
5. It is resolved to continue following Teaching and Evaluation methods for Academic year 2021-2022.
6. **It is resolved to conduct Value Added Course on “ZOHO Books” for III Sem students.**

Teaching methods:

Besides the conventional methods of teaching, we use modern technology i.e. using of LCD projector, display on U boards etc, for better understanding of concepts.

Evaluation of a student is done by the following procedure:

Internal Assessment (IA) I B.Com (General ,Computers & e-Commerce)

- Out of maximum 100 marks in each paper 25 marks shall be allocated for internal assessment for I.B.Com and (General ,Computers & e-Commerce). Out of these 25marks, 20 Marks are allocated for announced tests (i.e. IA-1 & IA-2). Two announced tests will be conducted and average of these two tests shall be deemed as the marks obtained by the student, and remaining 5 marks are allocated for the assignment. There is no minimum passing for IA.

Internal Assessment (IA) II & III B.Com (General & Computers)

- Out of maximum 100 marks in each paper 30 marks shall be allocated for internal assessment for II & III.B.Com (General & Computers). Out of these 30 marks, 20 Marks are allocated for announced tests (i.e. IA-1 & IA-2). Two announced tests will be conducted and average of these two tests shall be deemed as the marks obtained by the student, 5 marks allocated on the basis of candidate's percentage of attendance and remaining 5 marks are allocated for the assignment. There is no minimum passing for IA.

Semester Examinations (SE)

- The Semester Examinations will be in the form of a comprehensive examination covering the entire syllabus in each subject. It will be of 3 hours duration, with maximum 70 marks, irrespective of the number of credits allotted to it.
 - Even though the candidate is absent for two IA exams/obtained zero marks, the external marks are considered (if he/she gets 40/70) and the result shall be declared as 'PASS'
 - The pass mark shall be 30 out of 75 in the Semester end examination for I B.Com(General ,Computers & e-Commerce)
 - The pass mark shall be 28 out of 70 in the Semester end examination forII & III.B.Com and (General & Computers)
 - The maximum marks for each Paper shall be 100.(Internal 30 + External 70)
7. Discussed and recommended to organize certificate course online/offline, seminars, Guest lectures, Online Examinations and Workshops to upgrade the knowledge of students for Competitive Examinations for the approval of the Academic Council.
8. It is resolved to follow further changes if any in the Syllabus by the Competent Authority

Chairman

SEMESTER – I

Course Code	Title of the Course	Instructors Hours per week	Credits	Evaluation		
				CIA MARKS	SEE	
					MARKS	DURATION
COMT11B	Fundamentals of Accounting (Gen, CA & E-Com)	5	4	25	75	3 Hrs.
COMT12A	Business Organization and Management (Gen, CA & E-com)	5	4	25	75	3 Hrs.
COMT13	Business Environment(Gen)	5	4	25	75	3 Hrs.
COMT14S	Entrepreneur ship Development (Gen, CA &E-Com)	2	2	10	40	2Hrs



A. G & S.G. SIDDHARTHA DEGREE COLLEGE OF ARTS & SCIENCE

Vuyyuru-521165.

NAAC reaccredited at 'A' level

Autonomous -ISO 9001 – 2015 Certified

TITLE OF THE PAPER: Fundamentals of Accounting

Semester: I

Course Code	COMT11B	Course Delivery Method	Class Room / Blended Mode - Both
Credits	4	CIA Marks	25
No. of Lecture Hours / Week	5	Semester End Exam Marks	75
Total Number of Lecture Hours	75	Total Marks	100
Year of Introduction:	Year of Offering: 2020-21	Year of Revision: ----	Percentage of Revision: 0%
CLASS:	I.B.COM., (gen/computer/E-commerce)		

Learning Outcomes:

- 1) The main objective of fundamental accounting is to prepare final accounts, otherwise known as the financial statements
- 2) To provide information that is useful for making business and economic decisions
3. The students of this course will be active learners and develop awareness of emerging trends in fundamentals of accounting,
4. The course will provide decision making skills to the students in the financial analysis context,
5. This course will enable the students to combine theoretical knowledge and practice of fundamentals of accounting.

COURSE OUTCOMES:

At the end of the course, the student will able to

CO 1: Identify transactions and events that need to be recorded in the books of accounts.

CO 2: Equip with the knowledge of accounting process and preparation of final accounts of sole trader.

CO 3: Develop the skill of recording financial transactions and preparation of reports in accordance with GAAP.

CO 4: Analyze the difference between cash book and pass book in terms of balance and make reconciliation.

CO 5: Critically examine the balance sheets of a sole trader for different accounting

periods.

Syllabus

Unit	Learning Units	Lecture Hours
I	Introduction :Need for Accounting – Definition – Objectives, – Accounting Concepts and Conventions – GAAP - Accounting Cycle - Classification of Accounts and its Rules – Bookkeeping and Accounting - Double Entry Book-Keeping - Journalizing - Posting to Ledgers, Balancing of Ledger Accounts (including Problems).	15
II	Subsidiary Books: Types of Subsidiary Books - Cash Book, Three- column Cash Book- Petty Cash Book (including Problems).	15
III	Trial Balance and Rectification of Errors: Preparation of Trial balance - Errors – Meaning – Types of Errors – Rectification of Errors – Suspense Account (including Problems)	15
IV	Bank Reconciliation Statement: Need for Bank Reconciliation - Reasons for Difference between Cash Book and Pass Book Balances- Preparation of Bank Reconciliation Statement - Problems on both Favorable and Unfavorable Balance (including Problems).	15
V	Final Accounts: Preparation of Final Accounts: Trading account – Profit and Loss account – Balance Sheet – Final Accounts with Adjustments (including Problems).	15

Test Book Prefer:

1. Financial Accounting By: S.P.Jain & K.L. Narang. Kalyani Publishers – New Delhi.

Reference text books:

2. Financial Accounting – Himalaya Publishers
3. Financial Accounting – Pragathi prakesh Publishers

Suggested Co-Curricular Activities:

1. Quiz Programs
2. Problem Solving Exercises
3. Seminar
4. Group Discussions on problems relating to topics covered by syllabus
5. Collection of proforma of bills and promissory notes
6. Examinations (Scheduled and surprise test)
7. Bridge Course for Non-commerce Students



A. G & S.G. SIDDHARTHA DEGREE COLLEGE OF ARTS & SCIENCE

Vuyyuru-521165.

NAAC recredited at 'A' level
Autonomous -ISO 9001 – 2015 Certified

Model Question Paper

Commerce	I B.Com (Gen, CA &e-Com)	Semester-I	COMT11B
-----------------	-------------------------------------	-------------------	----------------

Fundamentals of Accounting

Max. Marks: 75

SECTION - A

Answer any FIVE of the following.

5 x 5 = 25

1. State any 5 advantages of Accounting. (CO1, L1)
2. Explain various types of Accounts and its rules. (CO1, L2)
3. Uses of Subsidiary Books. (CO2, L1)
4. Define 'Contra Entry'. What are the circumstances for passing contra entry? (CO2, L1)
5. Explain the methods for preparing Trial Balance? (CO3, L2)
6. Explain the 'Suspense account'. (CO3, L1)
7. Examine the need for Bank Reconciliation Statement. (CO4, L2)
8. Treatment of Outstanding and prepaid Expenses in final account. (CO5, L1)

SECTION – B

Answer the following

5 x10 = 50

Unit - I

9. A) Distinguish between Book Keeping and Accounting. (CO1, L2)
(OR)
B) Journalise the following transactions of Mr.Ramprasad. (CO1,L3)
- 2006 April 1 Ram prasad started business with cash Rs.50,000, furniture Rs.15,000 and stock Rs 10,000
- 2 Opened current account with Andhra Bank Rs.20,000
- 3 Received from Ragavan, a treasury order for Rs.1,000 and paid into bank.
- 5 Sold goods to Rama Rao for Rs 3,000
- 6 Drew from Bank for office use Rs.2,000
- 9 Sold goods for cash Rs.1,200-and out of that paid Rs.800 into Bank
- 10 Typewriter purchased by cheque Rs.5,000
- 12 Purchased goods from Sudhakar for Rs.6,000 and paid cash Rs. 2,000
- 14 Returned goods to Sudhakar Rs.200
- 16 Purchased pen,pencil,paper and ink for Rs.500 and paid by cheque
- 19 Sold goods to Krishna Rs.1,500 and received cash Rs.500 from him
- 22 Rama Rao became insolvent and 50% of the amount due is received.

Unit - II

10. A) Explain the different types of Subsidiary Books. (CO2, L2)

(OR)

- B) Enter the following transactions in a Triple Column Cash Book. (CO2,L3)

2006

- Jan. 1 Cash in hand Rs. 5,374, Balance at bank Rs. 15,490
3 Cash Sales Rs. 6,400
5 Paid into bank Rs. 7,000
6 Received a cheque for Rs. 700 from Satyam
8 Paid into bank Satyam's cheque
10 Paid to Anurag by cheque Rs. 980 and discount allowed by him Rs. 20.
12 Cash purchased Rs. 2,500
14 Withdrew from bank for office use Rs. 5,000
15 Received cheque for Rs. 950 from Lakshman allowed him discount Rs. 50
18 Cash Sales Rs. 7,500
19 Paid into bank Lakshman's cheque and Cash Rs. 4,000.
21 Cash paid for Stationery Rs. 120.
23 Paid Commission to Rakesh Rs. 500
25 Received cheque for Rs. 1,000 from Mohan and Paid the same into Bank.
27 Lakshman's cheque dishonoured.
29 Drew a cheque for Rs. 800 for personal use.
31 Paid Salaries by cheque Rs. 1,500 and by cash Rs. 500.
31 Bank charges Rs. 20 and Insurance Premium Rs. 520 as shown in Pass Book.

Unit – III

11. A) Define an Error? State the different types of Errors? (CO3, L2)

(OR)

b) A book keeper prepared a Trail Balance on 31st December, 2006 which showed a difference of Rs. 140 (excess credit). The difference was placed to a suspense account. The following errors were subsequently located.

- A sale of goods to Raja for Rs. 600 had been posted to the wrong side of his account.
- A purchase of goods for Rs. 1,640 from Uma has been posted to the personal account as Rs. 640.
- A credit sale of old furniture for Rs. 150 had been passed in sales day book.
- The discount received account had been cast short Rs. 60.
- Payment of rent Rs. 340 was debited to the personal account of the landlord.

Pass Journal entries to rectify the errors and prepare the suspense account. (CO 3 L4)

Unit - IV

12. A) Explain the causes for the distinction between Cash book and Pass book balance? (CO4, L2)

(OR)

B) On 31st March 2006 the bank balance of Dinesh Agnihotri appeared at Rs. 7,654 as per the bank columns of the cash book. On reconciling with the pass book, the following facts were ascertained:

1. That out of the cheques for Rs. 1,800 issued by him on 26th March, cheques worth Rs. 400 were presented to the bankers before 31st March and those worth Rs.500 were presented on 11th April. The other cheques were not so far cashed.
2. That a Bill Receivable for Rs. 1,000 was realised by the bankers on 29th March, but no corresponding entry was passed in the cash book.
3. That out of the up country cheques for Rs.2,800 paid in on 28th March, one cheque for Rs. 900 was not yet credited by the bankers.
4. That debit in respect of the bank charges amounting to Rs. 92.50 and credits in respect of interest on investment for Rs. 150 and dividends realised Rs. 800 were not passed through the cash book.
5. That a wrong debit of Rs. 350 relating to some other account appeared in pass book.

You are required to ascertain the bank balance shown by the bank pass book on 31st March 2006. (CO4,L3)

Unit - V

- .A. Explain the procedure for preparation of Final accounts for a sole trader.(CO5, L2)

(OR)

- B. From the following Trial Balance of Smt. Girija Stores, prepare final accounts for the year ending 31-12-2015. (CO 5,L4)

Trial Balance			
Debit Balance	Amount	Credit Balance	Amount
Purchases	70,000	Sales	1,00,000
Sales Returns	1,000	Capital	80,000
Carriage	500	Purchase returns	2,000
Salaries	1,500	Creditors	25,000
Rent	1,000	Commission	2,000
Insurance	500	Provision for bad debts	2,100
Debtors	20,000	Bills payable	5,000
Plant & Machinery	50,000		
Furniture	9,000		
Cash at Bank	20,000		
Opening Stock	25,000		
Bills receivable	16,000		
Wages	1,100		
Advertisement	500		
	2,16,100		2,16,100

Adjustments :

1. Closing stock Rs 30,000
2. Outstanding salaries Rs.200
3. Depreciate Machinery by 10%, Furniture by 5%.
4. Provide 5% reserve for bad debts on debtors.
5. Prepaid wages Rs.100.



A. G & S.G. SIDDHARTHA DEGREE COLLEGE OF ARTS & SCIENCE

Vuyyuru-521165.

NAAC reaccredited at 'A' level

Autonomous -ISO 9001 – 2015 Certified

TITLE OF THE PAPER: Business Organization and Management

Semester: I

Course Code	COMT12A	Course Delivery Method	Class Room / Blended Mode - Both
Credits	4	CIA Marks	25
No. of Lecture Hours / Week	5	Semester End Exam Marks	75
Total Number of Lecture Hours	75	Total Marks	100
Year of Introduction:	Year of Offering: 2012-13	Year of Revision: ----	Percentage of Revision: 0%
CLASS:	I.B.COM., (gen/computer/E-commerce)		

Course Objectives:

CO1-Recall the basic knowledge on conceptual areas such as commerce trade and industry of different types of business organizations. (PO4, PO5)

CO2-Have a demonstrated understanding on nature purpose and importance of different types of organizations.(PO4, PO5)

CO3-Articulate the fundamentals of joint-stock company as per companies Act 2013. (PO2, PO4, PO5)

CO4-Appraise the documentation and incorporation stages of a company. (PO2, PO4, PO5)

CO5-Discuss and implement the managerial traits and talents essential for managing business. (PO1, PO4, PO5)

Learning Outcomes :

At the end of the course, the student will be able to

- Understand different forms of business organizations.
- Comprehend the nature of Joint Stock Company and formalities to promote a Company.
- Describe the Social Responsibility of Business towards the society.
- Critically examine the various organizations of the business firms and judge the best among them.
- Design and plan to register a business firm. Prepare different documents to register a company at his own.
- Articulate new models of business organizations.

Syllabus

Unit	Learning Units	Lecture Hours
I	Introduction Concepts of Business, Trade, Industry and Commerce: Business – Meaning, Definition, Features and Functions of Business - Trade Classification – Aids to Trade – Industry Classification and Commerce - Factors Influencing the Choice of Suitable form of Organization.	15
II	Forms of Business Organizations: Features, Merits and Demerits of Sole Proprietorship and Partnership Business - Features Merits and Demerits of Joint Stock Companies - Public Sector Enterprises (PSEs) - Multinational Corporations (MNCs)- Differences between Private Limited Public Limited Company.	15
III	Company Incorporation: Preparation of Important Documents for Incorporation of Company - Certificate of Incorporation and Certificate of Commencement of Business - Contents of Memorandum and Articles of Association – Content of Prospectus.	15
IV	Management: Meaning Characteristics - Fayol's 14 Principles of Management - Administration Vs. Management - Levels of Management.	15
V	Functions of Management: Different Functions of Management - Meaning – Definition – Characteristics Merits and Demerits of Planning - Principles of Organization – Line and staff of Organization.	15

Text book:

Business Organization and management – R.K.Sharma, Monika Aggarwal, Rahul Sharma.

Reference Books:

1. Business Organization - C.D. Balaji and G. Prasad, Margham Publications, Chennai.
2. Business Organization - R.K. Sharma and Shashi K Gupta, Kalyani Publications.
3. Business Organization & Management: Sharma Shashi K. Gupta, Kalyani Publishers. ___

Curricular Activities:

Classroom activities: Face to face interactions in the class, conventional chalk dust method of teaching, using audio visual aids, synchronous, asynchronous and hybrid method of online teaching by using suitable platform, spot tests, listing assignments, conduct quizzes, Google class rooms organizing group discussions, preparing question banks.

Library activities: Reading books, journals and magazines, glancing question papers of previous Years. Organization of activities like seminars, workshops and conferences

Co-Curricular Activities:

- Book Reading, Student Seminars, Debates
- Quiz Programme
- Assignments Field studies (Individual/Group)



A. G & S.G. SIDDHARTHA DEGREE COLLEGE OF ARTS & SCIENCE
Vuyyuru-521165.

NAAC recredited at 'A' level
Autonomous -ISO 9001 – 2015 Certified

Model Question Paper

Commerce	I B.Com (Gen, CA &e-Com)	Semester-I	COMT12A
-----------------	-------------------------------------	-------------------	----------------

Title of the Paper: Business Organisation and Management

Time: 3 Hours

Max.

Marks:75

Section – A

Answer any FIVE of the following.

5x5=25

1. Explain the characteristics of Business. **CO1, L1**
2. Explain the types of Industries. **CO1, L1**
3. Explain the features of Sole proprietor. **CO2, L1**
4. What is partnership deed? **CO2, L1**
5. Define Joint Stock Company. What are its features? **CO3, L1**
6. Articles of Association. **CO3, L1**
7. Define Levels of Management. **CO4, L1**
8. Explain Merits of Planning. **CO5, L1**

Section – B

Answer the following.

5x10=50

Unit - I

9. A). What are the various types of Industries? **CO1,L1**
OR
B). Distinguish between Trade, Commerce and Industry. **CO1, L2**

Unit - II

10. A). Define Partnership firm. What are the characteristics of a partnership of the form of organization? **CO2, L1**
OR
B). Distinguish between private company and public company. **CO2, L2**

Unit – III

- A) What is Memorandum of Association? What are its contents? **CO3, L1OR**
B). Distinguish between Memorandum of Association and Articles of Association. **CO3, L2**

Unit – IV

- A) Explain Henry Fayol's Principles of Management. **CO4, L1**
OR
B) Define Management. Distinguish between Administration and Management. **CO4, L2**

Unit – V

13. A) Define Planning. What are its characteristics? **CO5, L1**
OR
B) Define Organisation. What are the principals of Organisation? **CO5, L1**



A. G & S.G. SIDDHARTHA DEGREE COLLEGE OF ARTS & SCIENCE

Vuyyuru-521165.

NAAC reaccredited at 'A' level

Autonomous -ISO 9001 – 2015 Certified

TITLE OF THE PAPER: Business Environment

Semester: I

Course Code	COMT13	Course Delivery Method	Class Room / Blended Mode - Both
Credits	4	CIA Marks	25
No. of Lecture Hours / Week	5	Semester End Exam Marks	75
Total Number of Lecture Hours	75	Total Marks	100
Year of Introduction:	Year of Offering: 2021-22	Year of Revision: ----	Percentage of Revision: 0%
CLASS:	I.B.COM., (gen)		

Course Objectives:

- This course aims at acquainting the students with emerging issues in business at the National and International level in the light of policies of liberalization and Globalization.
- evaluate the economic, social political and legal environment components in business decision making.

Course Outcomes:

CO1: Understand how an entity systematically explores the external environment in which business operates.

CO2: To enlighten/familiarize the impact of economic environment and its effect on government policies for development of business.

CO3: To acquire specialized knowledge relating to economic policies in India.

CO4: critically examine the economic, social political and legal environment components in business decision making.

CO5: synthesize multiple perspective to formulate responses to opportunities and institutions in international environment.

Syllabus
Business Environment

Unit	Learning Units	Lecture Hours
I	Overview of Business Environment: Business Environment – Meaning – Characteristics – Scope -Macro and Micro Dimensions of Business Environment -Environmental Analysis- Purpose & Techniques.	15
II	Economic Environment: Economic Environment – Nature of the Economy – Structure of Economy – Economic Policies & Planning the Economic Condition – NITI Ayog – National Development Council – Five Year Plans	15
III	Economic Policies: Economic Reforms and New Economic Policy – New Industrial Policy – Competition Law – Fiscal Policy – Objectives and Limitations – Monetary Policy and RBI	15
IV	Social, Political and Legal Environment: Concept of Social Responsibility of Business towards Stakeholders - Demonetization, GST and their Impact - Political Stability - Legal Changes.	15
V	Global Environment: Globalization – Meaning – Role of WTO – WTO Functions -IBRD– Trade Blocks, BRICS, SAARC, ASEAN in Globalization	15

Text book: . Rosy Joshi and Sangam Kapoor :Business Environment

Reference Books

1. K. Aswathappa : Essentials of Business Environment, Himalaya Publishing House
2. Francis Cherunilam : Business Environment, Himalaya Publishing House
3. Dr S Sankaran: : Business Environment, Margham Publications

Co-curricular activities

- ◆ Seminar on overview of business environment
- ◆ Debate on micro v/s macro dimensions of business environment
- ◆ Seminar on Monetary policies of RBI
- ◆ Debate on social, political and legal environment
- ◆ Group Discussions on Global environment and its impact on business
- ◆ To learn about NITI Ayog and National Development Council
- ◆ Seminars on Economic policies like New Industrial policy, Fiscal policy etc.
- ◆ Reports on WTO, BRICS, SAARC



A. G & S.G. SIDDHARTHA DEGREE COLLEGE OF ARTS & SCIENCE
Vuyyuru-521165.

NAAC recredited at 'A' level
Autonomous -ISO 9001 – 2015 Certified

Model Question Paper

Commerce	I B.Com (Gen)	Semester-I	COMT13
-----------------	----------------------	-------------------	---------------

Business Environment

Time: 3 Hours

75

Max Marks:

Section A

Answer any five of the following

25M

5 X 5M =

1. What are the objectives of Business Environment? (CO1, L1)
2. Write the features of socialism (CO1, L1)
3. Write about National Development Council (CO2, L1)
4. Explain the functions of NITI Aayog (CO2, L2)
5. Describe about the structure of Indian Economy (CO3, L2)
6. List out the revenue sources to State Government (CO3, L1)
7. What is Political Environment (CO4, L1)
8. Explain BRICS (CO5, L2)

Answer the following

5 X 10M = 50M

Unit - I

9. A) What is Business Environment? Explain the characteristics of Business Environment. (CO1, L1)

(or)

- B) Explain micro and macro environmental factors of business environment? (CO1, L2)

Unit - II

10. A) Define economic growth? What are the determinants of economic growth? (CO2, L1)

(or)

- B) Distinguish between NITI Aayog & Planning Commission. (CO2, L2)

Unit - III

11. A) Write about the monetary policy in India. (CO3, L2)

(or)

- B) Explain Competition Act, 2002. (CO3, L1)

Unit - IV

12. A) Write about the social responsibility of business. (CO4, L1)

(or)

- B) Explain the Impact of Demonetization on Indian Economy (CO4, L2)

Unit - V

13. A) Explain the role of WTO. (CO5, L2)

(or)



B) What is Globalization? Explain its Features. (CO5, L2)

A. G & S.G. SIDDHARTHA DEGREE COLLEGE OF ARTS & SCIENCE
Vuyyuru-521165.

NAAC recredited at 'A' level
Autonomous -ISO 9001 – 2015 Certified

TITLE OF THE PAPER: ENTREPRENEURSHIP DEVELOPMENT

<i>Commerce</i>	COMT14S	<i>2021-2022</i>	<i>I.B.com(comp)</i>
-----------------	---------	------------------	----------------------

Semester – I

Credits: 2

(Total 30 Hrs)

CO1: To familiarize students with various concepts used in understanding process involved in entrepreneurship and business formation and development.

CO2: To identify various sources to generate potential business ideas for new ventures and also enabling students to prepare a good feasibility report based on their understanding of the project appraisal techniques.

CO3: Understand the role of financial institutions in extending their support for the entrepreneur development and also acquiring thorough knowledge on various government policies and tax benefits supporting small scale industries.

Syllabus

Unit-I: Entrepreneurship: Entrepreneur characteristics – Classification of Entrepreneurships – Role of Entrepreneurship in economic development – Start-ups.

Unit-II: Idea Generation and Project Formulation: Sources of New Ideas in Entrepreneurships – Techniques for generating ideas - Preparation of Project Report – Content; Guidelines for Report preparation – Project Appraisal techniques – Economic Analysis; Financial Analysis; Market Analysis.

Unit-III: Institutions Supporting and Taxation Benefits: Central level Institutions: NABARD; SIDBI, NSIC – state level Institutions – DICs- SFC- SSIDC- Government Policy for SSIs- tax Incentives and Concessions – Non-tax Concessions Rehabilitation and Investment Allowances.

Reference Books:

1. Arya Kumar, Entrepreneurship, Pearson, Delhi, 2012.
2. Poornima M.CH., Entrepreneurship Development – Small Business Enterprises, Pearson, Delhi, 2009
3. Michael H. Morris, ET. al., Entrepreneurship and Innovation, Cengage Learning, New Delhi, 2011
4. Kanishka Bedi, Management and Entrepreneurship, Oxford University Press, Delhi, 2009
5. Anil Kumar, S., ET.al., Entrepreneurship Development, New Age International Publishers, New Delhi, 2011
6. Khanka, SS, Entrepreneurship Development, S. Chand, New Delhi.
7. Peter F. Drucker, Innovation and Entrepreneurship.

<i>Commerce</i>	COMT14S	<i>2021-2022</i>	<i>I.B.com(comp , Gen & E-com)</i>
-----------------	---------	------------------	--

Semester – I

**MODAL PAPER
ENTREPRENEURSHIP DEVELOPMENT**

Credits: 2

Section - A

I Answer any TWO of the following:

2 X 5M = 10M

1. Explain the functions of startup companies.
2. Explain the various sources of new ideas in developing a business idea
3. Explain any two project appraisal techniques
4. Write about Rehabilitation allowance and investment allowance.

Section - B

II Answer any THREE of the following:

3 X 10M = 30M

5. Explain the role of an Entrepreneur in the Economic development of a country.
6. Write about the Classification of Entrepreneurships
7. Develop guidelines for report preparation
8. Give an account of any three central level institutions.
9. Write about the Tax-Concessions offered to SSIs.

<i>Commerce</i>	SKILL DEVELOPMENT COURSES COB-301 G/C	<i>2021-2022</i>	<i>II.B.Com(gen/comp)</i>
-----------------	--	------------------	---------------------------

SYLLABUS:

ONLINE BUSINESS

Learning Outcomes:

After successful completion of the course, students will be able to;

- 1. Understand the online business and its advantages and disadvantages*
- 2. Recognize new channels of marketing, their scope and steps involved*
- 3. Analyze the procurement, payment process, security and shipping in onlinebusiness*
- 4. Create new marketing tools for online business*
- 5. Define search engine, payment gateways and SEO techniques.*

Section-I: 06 Hrs

Introduction to Online-business-Definition-Characteristics-Advantages ofOnline Business- Challenges- Differences between off-line business, e- commerce and Online Business.

Section-II: 10 Hrs

Online-business Strategies-Strategic Planning Process- Procurement -Logistics& Supply Chain Management- Customer Relationship management.

Section-III: 10 Hrs

Designing Online Business Website – Policies - Security & Legal Issues -Online Advertisements - Payment Gateways - Case Study

Co-curricular Activities Suggested: (4 hrs)

1. Assignments, Group discussion, Quiz etc.
2. Short practical training in computer lab
3. Identifying online business firms through internet
4. Invited Lectures by e-commerce operators
5. Working with Google and HTML advertisements.
6. Visit to a local online business firm.

AG & SG SIDDHARTHA DEGREE COLLEGE OF ARTS & SCIENCE VUYURU

(AUTONOMOUS)

**(MANAGED BY SIDDHARTHA ACADEMY OF GENERAL & TECHNICAL
EDUCATION VIJAYAWADA)**

<i>Commerce</i>	SKILL DEVELOPMENT COURSES COB-301 G/C	<i>2021-2022</i>	<i>II.B.Com(gen/comp)</i>
-----------------	--	------------------	---------------------------

MODEL PAPER:

ONLINE BUSINESS

DURATION: 2 HOURS

SECTION – A

Max:50

ANSWER ANY FOUR OF THE FOLLOWING QUESTIONS

(4x5=20M)

1. Define Online Business
2. Explain Characteristics of Online Business
3. E-Commerce
4. Online Business strategies
5. Supply Chain Management
6. Customer Relationship Management
7. Legal issues of Online Business
8. Online Advertising

SECTION – B

ANSWER ANY THREE OF THE FOLLOWING QUESTIONS

(3x10=30M)

9. Explain the Advantages of Online Business?
10. What are the differences between Offline and Online Business?
11. Explain about Online Business Strategic planning process
12. Describe Online Business Strategic Planning process
13. How do you Design Online Business Website
14. Describe the Policies of Online Business

AG & SG SIDDHARTHA DEGREE COLLEGE OF ARTS & SCIENCE VUYYURU

(AUTONOMOUS)

**(MANAGED BY SIDDHARTHA ACADEMY OF GENERAL & TECHNICAL
EDUCATION VIJAYAWADA)**

<i>Commerce</i>	SKILL DEVELOPMENT COURSES COB-301 G/C	<i>2021-2022</i>	<i>II.B.Com(gen/comp)</i>
-----------------	--	------------------	---------------------------

MODEL PAPER:

ONLINE BUSINESS

Marks	UNIT-I	UNIT-II	UNIT-III
	Introduction Online business	Online business Strategies	Designing Online Business Website
5Marks	3	3	2
10Marks	2	2	2
Weight age	35	35	30

<i>Commerce</i>	<i>CAA-302G/C</i>	<i>2021-2022</i>	<i>II.B.Com(gen/comp)</i>
-----------------	-------------------	------------------	---------------------------

SEMESTER –III

SYLLABUS

Advanced Accounting

Learning Outcomes

At the end of the course, the student will able to

- ❖ Understand the concept of Non-profit organization's and its accounting process
- ❖ Comprehend the concept of single-entry system and preparation of statement of affairs
- ❖ Familiarize with the legal formalities at the time of dissolution of the firm
- ❖ Prepare financial statements for partnership firm on dissolution of the firm
- ❖ Employ critical thinking skills to understand the difference between the dissolution of the firm and dissolution of partnership

Commerce	CAA-302G/C	2021-2022	II.B.Com(gen/comp)
----------	------------	-----------	--------------------

SEMESTER –III

SYLLABUS

Advanced Accounting

Unit-I: Accounting for Non Profit Organisations: Non Profit Entities- Meaning - Features of Non-Profit Entities –Provisions as per Sec 8 - Accounting Process- Preparation of Accounting Records - Receipts and Payments Account- Income and Expenditure Account - Preparation of Balance Sheet (including problems)

Unit-II: Single Entry System: Features – Differences between Single Entry and Double Entry – Disadvantages of Single Entry- Ascertainment of Profit and Preparation of Statement of Affairs (including Problems).

Unit-III: Hire Purchase System: Features –Difference between Hire Purchase and Installment Purchase Systems - Accounting Treatment in the Books of Hire Purchaser and Hire Vendor - Default and Repossession (including Problems)

Unit-IV: Partnership Accounts-I: Meaning – Partnership Deed - Fixed and Fluctuating Capitals- Accounting Treatment of Goodwill - Admission and Retirement of a Partner(including problems)

Unit-V: Partnership Accounts-II: Dissolution of a Partnership Firm – Application of Garner v/s Murray Rule in India – Insolvency of one or more Partners (including problems).

Reference Books:

1. Corporate Accounting – Haneef & Mukherji,
2. Corporate Accounting – RL Gupta & Radha swami
3. Corporate Accounting – P.C. Tulsian

AG & SG SIDDHARTHA DEGREE COLLEGE OF ARTS & SCIENCE VUYYURU
(AUTONOMOUS)
(MANAGED BY SIDDHARTHA ACADEMY OF GENERAL & TECHNICAL EDUCATION
VIJAYAWADA)

<i>Commerce</i>	<i>CAA-302G/C C</i>	<i>2021-2022</i>	<i>II.B.Com(gen/comp)</i>
-----------------	---------------------	------------------	---------------------------

SEMESTER –III

Advanced Accounting

Model Question Paper

Time: 3 hours

Max. Marks: 70

SECTION - A

I. Answer any TWO of the following questions

2 x 5 =10M

1. Write the features of Non Profit Organizations
2. Write about Repossession of Goods
3. Explain different types of partners
4. Garner vs Murraya Case

SECTION - B

II. Answer any FOUR of the following questions

4 x15 =60M

- 5).Discribe the Difeerrnce between Hire purchase and Installment Purchase System
- 3). write the Difference between Income and Expenditure account and Receipts and payment accounts
- 7) Write about fixed and fluctuating Capital Methods

8).The following is the Receipts and Payments Account of Indian Sports Club for the first year Ending as on 31-3-2014

Receipts	Rs.	Payments	Rs.
To Donations	5,00,000	By Pavilion constructed	4,00,0000
To Reserve fund (life and Entrance fee)	40,000	By Expenditure in connective with matches	9,000 600
To Receipts from matches	80,000	By Furniture	21,000
To Revenue receipts		By investment at cost	160000
Subscription	52,000	By Revenue Payments	
Locker Rent	500	Salaries	18,000
interest on securities	2400	Wages	6000
Sundries	3500	Insurance	3,500
		Telephone	2500
		Electricity	1100
		Sundry expenses	2100
		By Balance on hand	55200
	6,78,400		6,78,400

Additional information:

1. Donations received have to be Capitalised .
2. Outstanding bills for sundry expenses Rs.400
3. Wages unpaid for the year Rs.900
4. Salaries unpaid for the year Rs. 1700
5. Subscriptions outstanding for the year Rs. 2500

Prepare income and Expenditure account and the balance sheet for the year ended 31-3-2014

9). A motor company purchased two trucks on 1st Jan 2004. The cost price being Rs.56,000. The purchase is on Hire purchase basis. Rs. 15,000 being paid. On signing the agreement and there after Rs. 15,000 being paid annually for 3 years. Interest was charged at5%. Depreciation was written off at the rate of 20% per annum on the reducing installment system. Give necessary journal entries in the books of motor company.

10). A trader keeps his books by the single entry method. His position on 31st March 2018 was as follows:

Particulars	Amount
Cash at bank	9,000
Stock	60,000
Debtors	90,000
Machinery	150,000
Creditors	69,000

His position on 31st March 2019 was as follows :

Particulars	Amount
Cash at bank	12,000
Stock	75,000
Debtors	135,000
Machinery	135,000
Creditors	75,000

During the year the trader introduced Rs.30,000 as further capital in the business and withdraw Rs.900 per month. From the above you are required to ascertain the profit or loss made by the trader for the year ended 31st March 2019.

11). Kumar, Ramji are partners in a business sharing profits and losses equally. Their balance sheet on 31st December 2005 stood as under.

Liabilities	Amount	Assets	Amount
Creditors	2,000	Cash at bank	1,000
Capital Accounts:		Sundry Debtors	5,000
Kumar	40,000	Stock	10,000
Ramji	28,000	Machinery	18,000
		Furniture	5,000
		Buildings	31,000
	70,000		70,000

They decided to admit Sinha into firm on 1st Jan 2006 on the following terms.(a)

Sinha has to pay Rs. 25,000 for 1/4 share in future profits.

(b) Sinha has to pay Rs. 8,000 for goodwill.

(c) Machinery be depreciated by 10% and stock be depreciated by 10%.(d)

5% reserve for doubtful debts be created on debtors.

(e) Buildings to be appreciated by 20%.

Pass necessary journal entries to give effect to the above arrangement and the opening balance sheet of a Kumar, Ramji and Sinha.

12) Krishna and Kishore are equal partners in a business. They agreed to dissolve the partnership on 31st December 2006. On which date their Balance Sheet was as follows.

Liabilities	Amount	Assets	Amount
Sundry creditors	2,580	Cash at bank	1,500
Capital Accounts		Sundry debtors	2,775
Krishna 7,500		Stock	7,575
Kishore 6,000	13,500	Furniture	1,500
		Premises	3,000
	16,350		16,350

The assets realised as follows.

Premises Rs. 3,180, Furniture Rs.1,650, and Stock Rs. 6,900. The debtors realized Rs. 2,700. The creditors were paid Rs. 2,800 in full settlement

The realisation expenses amounted to Rs. 300

Pass necessary journal entries and show the realisation account, bank account and partners capital account.

AG & SG SIDDHARTHA DEGREE COLLEGE OF ARTS & SCIENCE VUYYURU
(AUTONOMOUS)
(MANAGED BY SIDDHARTHA ACADEMY OF GENERAL & TECHNICAL EDUCATION
VIJAYAWADA)

<i>Commerce</i>	<i>CAA-302G/C</i>	<i>2021-2022</i>	<i>II.B.Com(gen/comp)</i>
-----------------	-------------------	------------------	---------------------------

SEMESTER –III

Advanced Accounting

Guidelines to the paper setter

Marks	UNIT-I	UNIT-II	UNIT-III	UNIT-IV	UNIT-V
	Accounting for Share Capital	Profits prior to incorporation	Valuation of Goodwill and Shares:	Company Final Accounts:	Provisions of the Companies Act, 2013
5Marks	1	1	0	1	1
15Marks	1T+1P	1P	1T+1P	1T+1P	1T
Weight age	35	20	35	15	20

AG & SG SIDDHARTHA DEGREE COLLEGE OF ARTS & SCIENCE VUYYURU

(AUTONOMOUS)

(MANAGED BY SIDDHARTHA ACADEMY OF GENERAL & TECHNICAL EDUCATION
VIJAYAWADA)

Commerce	CBS -303G/C	2021-2022	<i>II.B.Com(gen/comp)</i>
----------	-------------	-----------	---------------------------

SEMESTER – III

Business Statistics

Objective: 1.The objective of this course is to impart knowledge on the application of Statistical tools and techniques in business decision making.

2. To make the students acquire the knowledge of Design, evaluate and apply correlation analysis

COURSE OUTCOMES

CO1- Describe the structure and characteristics of statistical data. able to present the data with diagrams

CO2- Calculate and interpret measures of central tendency and variability in statistical data.

CO3- Calculate and interpret measures of dispersion and skewness

CO4- Design, evaluate and apply correlation analysis.

CO5- To study the past behaviour of data and measure the effect of changes over the period of time.

Commerce	CBS-303G/C	2021-2022	II.B.Com(gen/comp)
----------	------------	-----------	--------------------

SEMESTER –III

SYLLABUS

Business Statistics

Unit 1 Introduction to Statistics:

Definition, Importance and limitation of statistics, Collection of data, Schedule and questionnaire, Frequency distribution, Tabulation

Unit 2: Measures of Central Tendency:

Characteristics of measures of central tendency, Types of Averages, Arithmetic Mean, Geometric Mean, Harmonic Mean, Median, Mode

Unit 3: Measures of dispersion and Skewness:

Properties of dispersion, Range, Quartile Deviation, Mean deviation, Standard deviation, Coefficient of Variation, Skewness Definition, Karl Pearson's and Bowley's Measures Of skewness

Unit 4: Measures of Relation:

Meaning and use of correlation, Types of correlation, Karl Pearson's correlation coefficient, Probable Error, Spearman's Rank correlation, Regression analysis comparison between correlation and Regression, Regression Equations

Unit 5: Analysis of Time Series & Index Numbers

Meaning and utility of time series, Components of Time series, Measurement of trend and Seasonal Variations, Techniques of Time series analysis, Methods of averages (Semi, Moving averages), Least square method, Index Numbers, Methods of Construction of Index numbers, Price index numbers, Limitations of index numbers

Suggested Readings:

1. Business Statistics Reddy, C.R Deep Publications.
2. Statistics-Problems and Solutions Kapoor V.K.

Revision of the syllabus 2021-22 (SEM -1,3,5)

Name of the Subject: **Business Statistics**

Subject Code: CBS303G/C

Academic Year	2021-22
Title of the paper	Business Statistics
Semester	III
Course code	CBS303G/C
CIA marks	30
Semester End marks	70
Total marks	100
Year of Introduction	2012-13
Year of Revision	2021-22
% of revision	25%

UNIT	Syllabus	Addition	Deletion
I	Introduction to Statistics: Definition, Importance and limitation of statistics, Collection of data, Schedule and questionnaire, Frequency distribution, Tabulation	Nil	Diagrams and Graphic Presentation of Data (including problems)
II	Measures of Central Tendency: Characteristics of measures of central tendency, Types of Averages, Arithmetic Mean, Geometric Mean, Harmonic Mean, Median, Mode	Nil	Nil
III	Measures of dispersion and Skewness: Properties of dispersion, Range, Quartile Deviation, Mean deviation, Standard deviation, Coefficient of Variation, Skewness Definition, Karl Pearson's and Bowley's Measures Of skewness	Skewness Measures of Skewness: Absolute and Relative Measures- Coefficient of Skewness: Karl Pearson's, Bowley's	Kurtosis: Meso kurtosis, Platy kurtosis and Leptokurtosis (including problems)
IV	Measures of Relation: Meaning and use of correlation, Types of correlation, Karl Pearson's correlation coefficient, Probable Error, Spearman's Rank correlation, Regression analysis comparison between correlation and Regression, Regression Equations	Nil	Nil

V	<p>Analysis of Time Series & Index Numbers Meaning and utility of time series, Components of Time series, Measurement of trend and Seasonal Variations, Techniques of Time series analysis, Methods of averages(Semi , Moving averages), Least square method, Index Numbers, Methods of Construction of Index numbers, Price index numbers, Limitations of index numbers.</p>	<p>Analysis of Time Series & Index Numbers Meaning and utility of time series, Components of Time series, Measurement of trend and Seasonal Variations, Techniques of Time series analysis, Methods of averages(Semi , Moving averages), Least square method, Index Numbers, Methods of Construction of Index numbers, Price index numbers, Limitations of index numbers.</p>	Nil
---	---	--	-----

Commerce	CBS-303G/C	2021-2022	II.B.Com(gen/comp)
----------	------------	-----------	--------------------

SEMESTER –III

Business Statistics

Model Question Paper

Time: 3 hours

Max. Marks: 70

SECTION - A

I. Answer any TWO of the following questions

2× 5 = 10 M

1. What are the Limitations of Statistics.
2. What are the different types of average?
3. Explain the Skewness?
4. Explain the Different types of Correlation ?

SECTION - B

II. Answer any FOUR of the following

4×15 =60 M

5. What is Questionnaire? Discuss the precautions to be taken while preparing a Questionnaire.
6. Calculate Mode.

C.I	10-20	20-30	30-40	40-50	50-60	60-70
F	4	7	16	20	15	8

7. Calculate Mean deviation.

C.I	10-15	15-20	20-25	25-30	30-35	35-40	40-45	45-50
F	8	10	12	15	10	7	8	5

8. Calculate Bowley's Skewness

X	6	12	18	24	20	16	6
F	4	7	9	18	15	10	5

9. Calculate Arithmetic Mean.

C.I	10-20	20-30	30-40	40-50	50-60	60-70	70-80
F	5	9	18	27	12	15	17

10. Calculate Karl Pearson's coefficient of correlation from the following.

A	44	80	76	48	52	72	68	56	60
B	48	75	54	60	63	69	72	51	57

.

11. What is Time Series Explain the Components of Time Series?

12. From the following data given Find fishers Index Number.

Commodity	Base year		Current year	
	Price	Quantity	Price	Quantity
A	6	50	10	56
B	2	100	2	120
C	4	60	6	60
D	10	30	12	24
E	8	40	12	36

AG & SG SIDDHARTHA DEGREE COLLEGE OF ARTS & SCIENCE VUYURU
(AUTONOMOUS)
(MANAGED BY SIDDHARTHA ACADEMY OF GENERAL & TECHNICAL EDUCATION
VIJAYAWADA)

<i>Commerce</i>	<i>CBS-303G/C</i>	<i>2021-2022</i>	<i>II.B.Com(gen/comp)</i>
-----------------	-------------------	------------------	---------------------------

SEMESTER –III

Business Statistics

Guidelines to the paper setter

Marks	UNIT-I	UNIT-II	UNIT-III	UNIT-IV	UNIT-V
	Introduction to Statistics	Measures of Central Tendency	Measures of dispersion and Skewness	Measures of Relation	Analysis of Time Series & Index Numbers
5Marks	1	1	1	1	0
15Marks	1T	2P	2P	1P	1T+1P
Weight age	20	35	35	20	30

<i>Commerce</i>	<i>CM 304 G</i>	<i>2021-2022</i>	<i>H.B.Com(gen)</i>
-----------------	-----------------	------------------	---------------------

SEMESTER –III

Marketing

Objective: 1.To acquire knowledge on marketing concepts, 4P's, to build applicable skills through variety internship opportunities

2. Student will gain understanding of consumer buyer behaviour, pricing strategies and ethical concept of marketing

COURSE OUTCOMES

CO1: To introduce the concepts of marketing and understand the factors influence the market environment.

C02: Analyze the consumer market models and enlightens consumer buyer behaviour models.

C03: Understand the concept of product and identify the need of product mix and product line decisions.

C04: Develop an idea about pricing strategies and pricing decisions.

C05: Enhance the students about decisions regarding promotion and distribution channels.

Commerce	CM 304 G	2021-2022	H.B.Com(gen)
----------	----------	-----------	--------------

SEMESTER –III

SYLLABUS

Marketing

Unit-I: Introduction: Concepts of Marketing: Need, Wants and Demand -Marketing Concepts – Marketing Mix - 4 P's of Marketing – Marketing Environment.

Unit-II: Consumer Behaviour and Market Segmentation: Buying DecisionProcess – Stages – Buying Behaviour – Market Segmentation –Bases of Segmentation - Selecting Segments – Advantages of Segmentation

Unit-III: Product Management: Product Classification – Levels of Product -Product Life Cycle - New Products, Product Mix and Product Line Decisions - Design, Branding, Packaging and Labelling.

Unit-IV: Pricing Decision: Factors Influencing Price – Determination of Price - Pricing Strategies: Skimming and Penetration Pricing.

Unit-V: Promotion and Distribution: Promotion Mix - Advertising - Salespromotion - Publicity – Public Relations - Personal Selling and Direct Marketing - Distribution Channels – Online Marketing

References:

1. Philip Kotler, Marketing Management, Prentice Hall of India.
2. Philip Kotler & Gary Armstrong, Principles of Marketing, Pearson PrenticeHall
3. Stanton J. William & Charles Futrel, Fundamentals of Marketing, McGrawHill Company

<i>Commerce</i>	<i>CM 304G</i>	<i>2021-2022</i>	<i>II..B.Com(gen)</i>
-----------------	----------------	------------------	-----------------------

SEMESTER –III

Model paper

Marketing

Time: 3 hrs

Max. Marks: 70

SECTION- A

I. Answer any TWO of the following questions 2x 5= 10M

1. Selling Concept
2. What is Consumer behavior
3. What is New Product
4. Online Marketing

SECTION- B

II. Answer any FOUR of the following questions 4 x 15 = 60M

5. Describe 4P's of Marketing
6. What are the Different Concepts of Marketing
7. What is Market Segmentation?
8. Describe Product Life Cycle.
9. What are the Factor Influencing Price Determination
10. What are the differences Between Personal selling and Direct Marketing?
11. Advantages and disadvantages Packaging and labelling
12. Types of Distribution channels

<i>Commerce</i>	<i>CM 304 G</i>	<i>2021-2022</i>	<i>II..B.Com(gen)</i>
-----------------	-----------------	------------------	-----------------------

SEMESTER-III

Guidelines to the paper setter

Marketing

Marks	UNIT-I	UNIT-II	UNIT-III	UNIT-IV	UNIT-V
	Introduction	Consumer Markets and buyer Behavior	Product Management	Pricing decision	Promotion and Distribution
5Marks	1	1	1	--	1
15Marks	2	1	2	1	2
Weightage	35	20	35	15	35

AG & SG SIDDHARTHA DEGREE COLLEGE OF ARTS & SCIENCE VUYYURU
(AUTONOMOUS)
(MANAGED BY SIDDHARTHA ACADEMY OF GENERAL & TECHNICAL EDUCATION
VIJAYAWADA)

<i>Commerce</i>	<i>CBL-501(U)</i>	<i>2021-2022</i>	<i>III B.Com(gen/comp)</i>
-----------------	-------------------	------------------	----------------------------

SEMESTER –V

SYLLABUS

Business Leadership

Unit-I: Introductory: Leadership - Traits, Skills and Styles- LeadershipDevelopment - Qualities of a Good Leader.

Unit-II: Decision-Making and Leadership: Leadership for Sustainability - Power, Influence, Impact - Leadership Practices - Organizations and Groups: Organizational Culture and Leadership - Leadership in Business Organizations

Unit-III: Special Topics: Profiles of a few Inspirational Leaders in Business –Jemshedji Tata - Aditya Birla - Swaraj Paul - L N Mittal - N R Narayana Murthy - Azim Premji, etc.

References:

1. Northouse, Peter G., Leadership: Theory and Practice, Sage Publications.
2. Daloz Parks, S., Leadership can be taught: A Bold Approach for a Complex World, Boston: Harvard Business School Press.
3. Drucker Foundation (Ed.), Leading Beyond the Walls, San Francisco: Jossey Bass.
4. Al Gini and Ronald M. Green, Virtues of Outstanding Leaders: Leadership and Character, John Wiley & Sons Inc.
5. S Balasubramanian, The Art of Business Leadership – Indian Experiences, Sage Publications

AG & SG SIDDHARTHA DEGREE COLLEGE OF ARTS & SCIENCE VUYYURU
(AUTONOMOUS)
(MANAGED BY SIDDHARTHA ACADEMY OF GENERAL & TECHNICAL EDUCATION
VIJAYAWADA)

<i>Commerce</i>	<i>CBL-501(U)</i>	<i>2021-2022</i>	<i>III B.Com(gen/comp)</i>
-----------------	-------------------	------------------	----------------------------

SEMESTER –V

Model paper

Business Leadership

Time: 2 hrs

Max. Marks: 50

SECTION- A

I. Answer any FOUR of the following questions

4 x 5= 20M

1. Leadership
2. Trait
3. Power
4. Influence
5. Aditya Birla
6. Azim Premji

SECTION- B

II. Answer any THREE of the following questions

3 x 10 = 30M

7. Explain the qualities of Good leader
8. Explain Different types of leader ship Practices
9. Explain the leadership in Business Organizations
10. Explain the Profiles of Jemshedji Tata
11. Explain the different Styles of Leadership
12. Explain the Profiles of Narayana Murthy

AG & SG SIDDHARTHA DEGREE COLLEGE OF ARTS & SCIENCE VUYYURU
(AUTONOMOUS)
(MANAGED BY SIDDHARTHA ACADEMY OF GENERAL & TECHNICAL EDUCATION
VIJAYAWADA)

<i>Commerce</i>	<i>CBL-501(U) G/C C</i>	<i>2021-2022</i>	<i>III B.Com(gen/comp)</i>
-----------------	-------------------------	------------------	----------------------------

SEMESTER –V

Business Leadership

Guidelines to the paper setter

	UNIT-I	UNIT-II	UNIT-III
	Introduction	Decision making and Leadership	Special Topics
5 Marks questions	2	2	2
10 Marks questions	2	2	2
Weight age	30	30	30

AG & SG SIDDHARTHA DEGREE COLLEGE OF ARTS & SCIENCE VUYYURU
(AUTONOMOUS)

(MANAGED BY SIDDHARTHA ACADEMY OF GENERAL & TECHNICAL EDUCATION VIJAYAWADA)

<i>Commerce</i>	<i>CCOA-502 G/C C</i>	<i>2021-2022</i>	<i>III B.Com(gen/comp)</i>
-----------------	-----------------------	------------------	----------------------------

SEMESTER –V

SYLLABUS

Cost Accounting

Unit-I:Introduction: Distinguish between Financial Accounting, Cost Accounting and management accounting - Cost Concepts and Classification – Cost Centre and Cost Unit – Preparation of Cost Sheet.

Unit-II: Elements of Cost: Materials: Material control – Selective control, ABC technique – Methods of pricing issues – FIFO, LIFO, Weighted average, Base stock methods, choice of method(including problems).

Unit-III: Labour and Overheads: Labour: Control of labour costs – time keeping and timebooking – Idle time –Methods of remuneration – labour incentives schemes - Overheads:Allocation and apportionment of overheads – Machine hour rate.

Unit-IV: Methods of Costing: Job costing – Process costing - treatment of normal and abnormal process losses – preparation of process cost accounts – treatment of waste and scrap, joint products and by products (including problems).

Unit -V: Costing Techniques: Marginal Costing – Standard costing – Variance Analysis (including problems).

References:

1. S.P. Jain and K.L. Narang – Advanced Cost Accounting, Kalyani Publishers, Ludhiana.
2. M.N. Aurora – A test book of Cost Accounting, Vikas Publishing House Pvt. Ltd.
3. S.P. Iyengar – Cost Accounting, Sultan Chand & Sons.
4. Nigam & Sharma – Cost Accounting Principles and Applications, S.Chand & Sons.
5. S.N .Maheswari – Principles of Management Accounting.
6. I.M .Pandey – Management Accounting, Vikas Publishing House Pvt. Ltd.

Commerce	CCOA-502G/C C	2021-2022	B.Com(gen/comp)
----------	---------------	-----------	-----------------

SEMESTER –V

Model paper

Cost Accounting

TIME -3hrs

SECTION-A

Max. Marks: 70

I. Answer any TWO of the following:

2x5=10M

1. Define Cost Accounting? Explain its Advantages.
2. Explain about FIFO Method.
3. What are the essential features of a good wage system?
4. Explain about BEP Analysis.

SECTION-B

II. Answer any FOUR of the following:

4x15=60M

5. Distinguish between cost accounting and financial accounting
6. From the following particulars you are required to prepare a cost sheet for the year ending 31.12.2009.

Rs.

Stock of finished goods 31-12-2008	72,800.
Stock of raw materials on 31-12-2008	33,280.
Purchase of raw materials	7,59,200.
Wages	5,16,880.
Sales	15,39,200.
Stock of finished goods on 31-12-2009	78,000.
Stock of Raw materials on 31-12-2009	35,360
Works overhead charges	1,29,220
Office overheads	70,161

The company is intending to send a quotation for a large plant. The estimated material cost is Rs. 52,000 and wages Rs. 31,200. The quotation is to make a profit of 20% on selling price. Show the amount of quotation price.

7. X Ltd has purchased and issued the material in the following order

Jan	1	Purchased	300 units @Rs.3/-per units
	4	purchased	600 <u>units@Rs.4/-per</u> units
	6	Issue	500 units
	10	Purchased	700 <u>units@Rs.4/</u> per units
	15	Issue	800 units
	20.	purchased	300 units @Rs.5/per units
	23.	issue	100 units

Ascertain the quantity of closing stock as on 31st January and state what will be its value (in each case) if issues are made under the First in first out method:

8. From the following information relating to a worker. Calculate which of the following methods of wage payment is beneficial to the worker:

- (a) Time rate
- (b) Piece rate
- (c) Halsey plan.
- (I) Standard Time in a week 45 hrs
- (ii) Standard weekly production 450 units.
- (III) Actual time taken by the worker 40hrs.
- (Iv) Piece rate Rs.2 per units
- (v) Hourly rate Rs.25.

9. Product x is obtained after it is processed through three distinct process. The following cost information is available for the operations:

particulars	Total	I	II	III
Material	5,625	2,600	2,000	1,025
Direct wages	7,330	2,250	3,680	1,400
Production over heads	7,330	–	–	–

500 units at Rs.4per unit were introduced in process .production over head to be distributed at 100% on Direct wages

The actual output and normal loss of the respective processes are:

	Output unit	Normal loss on input	Value of scrap per unit
Process-I	450	10%	Rs.2
Process-II	340	20%	Rs.4
Process-III	270	25%	Rs.5

There is no stock or work-in-progress in any process.

Prepare process accounts.

10. From the following information pertaining to the two years, calculate.

(a) P/V ratio

(b) Amount of sales to earn profit of Rs40,000

(c) profit on sales Rs.1,20,000.

Years	Sales	Profit
1996	1,40,000	15,000
1997	1,60,000	20,000

11. You are required to calculate from the following data:

(a) Material price variance

(b) Material cost variance

(c) Material usage variance

Standard material cost to produce one tone of chemical "P" is

500 kg of material X @Rs.15 per kg.

750 kg of material Y @Rs.10 per kg.

1000 kg of material Z @Rs.12 per kg.

During the period 100 tons of Chemical P wear produced from the usage of

6000 kg of material X@Rs.14 per kg.

8000 kg material Y @Rs .12 per kg.

10,500 kg materialZ@Rs.15 per kg.

12. The Costing records of Gopi Engineering Company for job 777 reveals Materials Rs 6,015

Wages: Dept .X : 100 Hours @ Rs 4.50 per hour

Dept .Y : 65 Hours @ Rs 3.00 per hour

Dept .Z : 35 Hours @ Rs 7.50 per hour

Over head expenses for these three departments were estimated as follows.

Variable overheads :

Dept .X : Rs 10,000 for 2,500 labour hours

Dept .Y Rs 6,000 for 2,000 labour hours

Dept .Z : Rs 4,000 for 500 labour hours

Fixed overheads: estimated at Rs 40,000 for 10,000 Normal Working Hours .your are required to calculate the cost of job No 777.

Commerce	CCOA-502G/C C	2021-2022	B.Com(gen/comp)
----------	---------------	-----------	-----------------

Cost Accounting

SEMESTER –V

Guidelines to the paper setter

	UNIT-I	UNIT-II	UNIT-III	UNIT-IV	UNIT-V
	Introduction	Elements of Cost	Labour and Over heads	Methods of Costing	Costing Techniques
5 Marks questions	1	1	1	0	1
15 Marks questions	2(1T+1P)	1	1	2	2
Weight age	35	20	20	30	35

<i>Commerce</i>	<i>CTAX-503C C</i>	<i>2021-2022</i>	<i>III.B.Com(comp)</i>
-----------------	--------------------	------------------	------------------------

SEMESTER –V

TAXATION
SYLLABUS

Unit-I: Introduction: Objectives - Principles of Taxation - Brief History - Basic Concepts; Capital and Revenue; Basis of Charge - Exempted Incomes - Residential Status – Incidence of Taxation.

Unit-II: Direct and Indirect Taxes – Service Tax – VAT – Central Sales Tax – Latest Developments.

Unit-III: Computation of income under different heads: Income from Salary; Income from House Property; Deductions u/s 80C to 80U - Income from Capital Gains; Income from Other Sources (simple problems).

Unit-IV: Taxation System in India: Objectives; Tax Holiday; Modes of Tax Recovery (Section 190 and 202); Payments and Refunds; Filing of Returns.

Unit-V: Tax Planning: Tax Avoidance and Tax Evasion; Penalties and Prosecutions; Income Tax Authorities.

References:

1. Vinod K. Singhania Direct Taxes - Law and Practice, Taxman Publication.
2. B.B. Lal: Direct Taxes, Konark Publisher (P) Ltd.
3. Bhagwati Prasad: Direct Taxes – Law and Practice, Wishwa Prakashan.
4. Dr. Mehrotra and Goyal: Direct Taxes – Law and Practice, Sahitya Bhavan Publication.

Commerce	CTAX-503C C	2021-2022	III.B.Com(comp)
----------	-------------	-----------	-----------------

SEMESTER –V

TAXATION
Model Question Paper

Time: 3 Hrs

Max. Marks: 70

SECTION – A

I. Answer any TWO of the following

2X 5 = 10M

1. Explain the principle of Taxation
2. What is VAT
3. U/S 80c
4. Tax Evasion

SECTION – B

II. Answer any Four of the following

4 x15 =60M

5. Give 10 Examples of Incomes Exempted u/s 10.
6. What is Service tax ? Explain different taxable service
7. From the following particulars of sriram, a manger of a firm, compute his taxableincome from salary for the A. Y 2017-18
 - a) Basic pay Rs 6000 P.M
 - b) Dearness allowance Rs 400 P.M
 - c) Own contribution to R.P.F Rs 3000 P.M
 - d)Employee’s contribution to R.P.F Rs 3000 P.M
 - e) Interested credited to R.P.F 13% P.A Rs 4680
 - f) House rent allowance Rs 7200P.M rent paid in Delhi Rs5000 P.M
 - g) Medical allowance Rs100 P.M
 - h) Entertainment allowance Rs. 300 P.M

8. Compute income from House property for the assessment year 2016-17

Municipal valuation 16,000 P A. Fair rent 1,80,000 P.A ,Standard rent 1,50,000 P.A , Rentreceived 1,72,000 P A Municipal taxes 10% Municipal taxes are borne by the owner. Fireinsurance Rs 3000, Interest on money borrowed for construction of House property paid Rs .36, 000 The House is let-out throughout the previous year.

9. Mr. Prasad submits the following particulars about sale of assets during 2016-17.

<u>Particulars</u>	<u>Jewellery</u>	<u>Plot</u>	<u>Gold</u>
Sale Price	12, 00,000	50, 80,000	10,20,000
Expenses on sale	10,000	36,000	Nil
Cost of Acquisition	90,000	4, 20,000	1,30,000
Year of Acquisition	1989-90	1986-87	2003-04
CII	172	140	463

He has purchased a house for Rs.27, 00,000 on 1-3-2020.

Calculate the amount of taxable capital gain. CII for 2021-2022 is: 317

10 .Explain the Modes of Tax Recovery

11. Difference between Tax Planning and Tax Evasion

12. Mention the different Kinds of Incomes Specifically mentioned as Chargeable to tax under the head "Income from Other Sources

<i>Commerce</i>	<i>CTAX-503C C</i>	<i>2021-2022</i>	<i>III.B.Com(comp)</i>
-----------------	--------------------	------------------	------------------------

SEMESTER –V

TAXATION
Guidelines to the paper setter

Marks	UNIT-I	UNIT-II	UNIT-III	UNIT-IV	UNIT-V
	Introduction	Direct and Indirect taxes	Computation of income under different heads	Taxation System in India	Tax Planning
5Marks	1	1	1	0	1
15Marks	1T	1T	3P+1T	1T	1T
Weight age	20	20	65	15	20

<i>Commerce</i>	CGST-503G/C	2021-2022	<i>III.B.Com(gen)</i>
-----------------	-------------	-----------	-----------------------

SEMESTER –V

GOODS &SERVICE TAX FUNDAMENTALS

SYLLABUS

GOODS &SERVICE TAX FUNDAMENTALS

Unit I: Introduction: Overview of GST - Concepts – Limitations of VAT – Need for Tax Reforms - Justification for introduction of GST - Shortcomings and advantages at the Central Level and State Level on introduction of GST- Process of Introduction of GST - Constitutional Amendments.

Unit II: GST:Principles – Models of GST: Australian, Canadian, Kelkar-Shah – BagchiPoddar -Comprehensive structure of GST model in India: Single, Dual GST– Transactions covered under GST.

Unit-III:Taxes and Duties: Subsumed under GST - Taxes and Duties outside the purview of GST: Tax on items containing Alcohol – Tax on Petroleum products - Tax on Tobacco products - Taxation of Services

Unit-IV: Inter-State Goods and Services Tax: Major advantages of IGST Model – Interstate Goods and Service Tax: Transactions within a State under GST – Interstate Transactions under GST - Illustrations.

Unit-V: Time of Supply of Goods & Services: Value of Supply - Input Tax Credit – Distribution of Credit -Matching of Input Tax Credit - Availability of credit in special circumstances- Cross utilization of ITC between the Central GST and the State GST.

References:

1. Goods and Services Tax in India – Notifications on different dates.
2. GST Bill 2012.
3. Background Material on Model GST Law, Sahitya Bhawan Publications, Hospital Road, Agra - 282 003.
4. The Central Goods and Services Tax Act, 2017, NO. 12 OF 2017 Published by Authority, Ministry of Law and Justice, New Delhi, the 12th April, 2017.

Commerce	CGST-503G/C	2021-2022	III.B.Com(gen)
----------	-------------	-----------	----------------

SEMESTER –V GOODS &SERVICE TAX FUNDAMENTALS

MODEL PAPER

TIME -3hrs

Max. Marks: 70

SECTION-A

I. Answer any TWO of the following

2x5=10M

1. What is GST?
2. Dual GST
3. Subsumed under GST
4. Central GST

SECTION-B

II. Answer any FOUR of the following

4x15=60M

5. What are the advantages of Goods and Services Tax
6. What is the Comprehensive Structure of GST in India?
7. Write about Australian Model of GST
8. Explain the Taxes and Duties outside the Purview of GST
9. What are the advantages of IGST?
10. Explain about interstate transactions under GST
11. What is Time supply of goods and services?
12. What is input tax credit and explain it with suitable examples.

<i>Commerce</i>	CGST-503G/C	2021-2022	<i>III.B.Com(gen)</i>
-----------------	-------------	-----------	-----------------------

GOODS & SERVICE TAX FUNDAMENTALS

SEMESTER –V

Guidelines to the paper setter

Marks	UNIT-I	UNIT-II	UNIT-III	UNIT-IV	UNIT-V
	Inrtoduction	GST:Princip les	Taxes and Duties	Inter-State Goods and Services Tax	Time of Supply of Goods & Services
5Marks	1	1	1	0	1
15Marks	1	2	1	2	2
Weight age	20	35	20	30	35

<i>Commerce</i>	<i>CCG-504G/C C</i>	<i>2021-2022</i>	<i>III.B.Com(gen/comp)</i>
-----------------	---------------------	------------------	----------------------------

SEMESTER-V

SYLLABUS

Commercial Geography

Unit -I: The Earth: Internal structure of the Earth – Latitude – Longitude – Realms of the Earth – Evolution of the Earth – Environmental pollution - Global Warming - Measures to be taken to protect the Earth.

Unit -II: India – Agriculture: Land Use - Soils - Major crops – Food and Non-food Crops – Importance of Agriculture – Problems in Agriculture – Agriculture Development.

Unit -III: India – Forestry: Forests – Status of Forests in Andhra Pradesh – Forest (Conservation) Act, 1980 – Compensatory Afforestation Fund (CAF) Bill, 2015 - Forest Rights Act, 2006 and its Relevance – Need for protection of Forestry.

Unit -IV: India – Minerals and Mining: Minerals – Renewable and non Renewable – Use of Minerals – Mines – Coal, Barites, etc. – Singareni Coal mines and Mangampeta Barites – Districtwise Profile.

Unit-V: India – Water Resources – Rivers: Water resources - Rationality and equitable use of water – Protection measures - Rivers - Perennial and peninsular Rivers - Interlinking of Rivers - Experience of India and Andhra Pradesh.

References:

1. Shabiar Ahmad; Quazi, Natural Resource Consumption and Environment Management, APH Publishing Corporation.
2. Tarachand, Economic and Commercial Geography of India, Vikas Publishing House.
3. Dr. S. Sankaran, Commercial Geography, Margam Publications, Chennai.
4. C. B. Memoria, Commercial Geography, Lal Agarwal & Co.

Commerce	CCG-504G/C C	2021-2022	III.B.Com(gen/comp)
----------	--------------	-----------	---------------------

SEMESTER –V

Model paper

Commercial Geography

Time: 3 hrs

Max. Marks: 70

SECTION- A

I. Answer any Two of the following questions

2 x 5= 10M

1. Global warming
2. Non-food crops
3. Singareni Coal Mines
4. Krishna River

SECTION- B

II. Answer any FOUR of the following questions

4 x 15 = 60M

5. Explain the internal structure of the Earth
6. What are the measures to be taken to protect the Earth
7. Explain about different types of soils.
8. Explain forest conservation Act 1980.
9. Describe the need for protection of forests
10. Explain renewable and non renewable minerals
11. Explain the importance of interlinking of rivers
12. What are the problems facing by the farmers in India?

<i>Commerce</i>	<i>CCG-504G/C C</i>	<i>2021-2022</i>	<i>III.B.Com(gen/comp)</i>
-----------------	---------------------	------------------	----------------------------

SEMESTER –V

Commercial Geography

Guidelines to the paper setter

	UNIT-I	UNIT-II	UNIT-III	UNIT-IV	UNIT-V
	The Earth	India-Agriculture	India-Forestry	India-Minerals and Mining	India-Water resources-Rivers
5 Marks questions	1	1	0	1	1
15 Marks questions	2	2	2	1	1
Weight age	35	35	30	20	20

<i>Commerce</i>	<i>CCB 505CE G/C</i>	<i>2021-2022</i>	<i>III.B.Com(gen)</i>
-----------------	----------------------	------------------	-----------------------

SEMESTER –V

SYLLABUS

Central Banking

Unit-I: Introduction: Evolution and Functions of Central Bank - Development of Central Banks in Developed and Developing countries - Trends in Central Bank Functions.

Unit-II: Central banking in India: Reserve Bank of India - Constitution and Governance, Recent Developments, RBI Act. - Interface between RBI and Banks.

Unit-III: Monetary and Credit Policies: Monetary policy statements of RBI - CRR - SLR -Repo Rates - Reverse Repo Rates - Currency in circulation - Credit control measures.

Unit-IV: Inflation and price control by RBI: Intervention mechanisms - Exchange rate stability - Rupee value - Controlling measures.

Unit-V: Supervision and Regulation: Supervision of Banks - Basle Norms, Prudential Norms, Effect of liberalization and Globalization - Checking of money laundering and frauds.

References:

1. Reserve Bank of India Publication, Functions and Working of the RBI.
2. Vasant Desai, Central Banking and Economic Development, Himalaya Publishing.
3. S. Panandikar, Banking in India, Orient Longman.
4. Reserve Bank of India Publication, Report on Trends and Progress of Banking in India.
5. Annual Reports of Reserve Bank of India.
6. Rita Swami, Indian Banking System, International Publishing House Pt. Ltd..

<i>Commerce</i>	<i>CCB 505CE G/C</i>	<i>2021-2022</i>	<i>III.B.Com(gen)</i>
-----------------	----------------------	------------------	-----------------------

SEMESTER –V

Model paper

Central Banking

Time: 3 hrs

Max. Marks: 70

SECTION- A

I. Answer any TWO of the following questions 2 x 5= 10M

1. Evolution of Central Bank
2. RBI Act 1934
3. Statutory liquidity Ratio
4. Exchange Rate

SECTION- B

II. Answer any FOUR of the following questions 4 x 15 = 60M

5. Describe the functions Central Bank.
6. Explain the differences between RBI and Commercial banks
7. State the Role of RBI in Economic Development
8. What are the various weapons of credit control available to RBI
9. What is Cash Reserve Ratio? Explain its importance
10. Bring out Clearly the Exchange Control Function of the RBI
11. Explain Basle Norms and Prudential Norms.
12. Explain the Checking of Money laundering and frauds.

<i>Commerce</i>	<i>CCB 505CE G/C</i>	<i>2021-2022</i>	<i>III.B.Com(gen)</i>
-----------------	----------------------	------------------	-----------------------

SEMESTER –V

Guidelines to the paper setter

Central Banking

Marks	UNIT-I	UNIT-II	UNIT-III	UNIT-IV	UNIT-V
	Introduction	Central banking in India	Monetary and Credit policies	Inflation and price control by RBI	Supervision and Regulation
5Marks	1	1	1	1	0
15Marks	1	2	2	1	2
Weight age	20	35	35	20	30

<i>Commerce</i>	<i>CRC-506 CE G/C</i>	<i>2021-2022</i>	<i>III.B.Com(gen)</i>
-----------------	-----------------------	------------------	-----------------------

SEMESTER –V

SYLLABUS

Rural and Farm Credit

Unit-I: Rural Credit: Objectives and Significance of Rural credit - Classification of rural credit - General Credit Card (GCC) – Financial Inclusion - Rupay Card.

Unit-II: Rural Credit Agencies: Institutional and Non-institutional Agencies for financing agriculture and Rural development - Self-Help Groups (SHG) - Financing for Rural Industries.

Unit-III: Farm Credit: Scope - Importance of farm credit - Principles of Farm Credit -Types-Cost of Credit - - problems and remedial measures - Kisan Credit Card (KCC) Scheme.

Unit-IV: Sources of Farm Credit: Cooperative Credit: PACS - APCOB - NABARD SLBC-Lead Bank Scheme - Role of Commercial and Regional Rural Banks - Problems of recovery and over dues.

Unit-V: Farm Credit Analysis: Eligibility Conditions - Analysis of 3 R's (Return, Repayment Capacity and Risk-bearing Capacity) - Analysis of 3 C's of Credit (Character, Capacity and Capital) - Crop index reflecting use and farm credit - Rural Credit Survey Reports..

References:

1. National Bank of Agricultural and Rural Development (NABARD) Annual report.
2. Economic Survey, Government of India.
3. Rural Development, Sundaram I.S., Himalaya Publishing House, Mumbai.
4. Rural Credit in India, C.S.Rayudu, Mittal Publications.
5. Farm Credit and Co-operatives in India, Tiruloati V., Naidu. V T Naidu, Vora & Co. Pub.Ltd.

Project Work: Rural Credit survey/Banking operations/Credit Appraisal

AG & SG SIDDHARTHA DEGREE COLLEGE OF ARTS & SCIENCE VUYURU
(AUTONOMOUS)
(MANAGED BY SIDDHARTHA ACADEMY OF GENERAL & TECHNICAL EDUCATION
VIJAYAWADA)

<i>Commerce</i>	<i>CRC-506 CE G/C</i>	<i>2021-2022</i>	<i>III.B.Com(gen)</i>
-----------------	-----------------------	------------------	-----------------------

SEMESTER –V
Model paper

Rural and Farm Credit

Time: 3 hrs

Max. Marks: 70

SECTION- A

I. Answer any TWO of the following questions

2x 5= 10M

1. Rural Credit
2. Self Help Groups
3. Kisan Credit Card
4. Repayment Capacity

SECTION- B

II. Answer any FOUR of the following questions

4 x 15 = 60M

5. Describe the significance of Rural Credit
6. Explain Classification of Rural Credit
7. What are Institutional agencies for Financing Agricultural?
8. Explain advantages and disadvantages of Self-Help Groups
9. Explain the principles of Farm Credit
10. Write about NABARD
11. Explain the role of Regional Rural Banks in Farm Credit
12. What is the Analysis of 3C'S of Credit?

AG & SG SIDDHARTHA DEGREE COLLEGE OF ARTS & SCIENCE VUYYURU
(AUTONOMOUS)
(MANAGED BY SIDDHARTHA ACADEMY OF GENERAL & TECHNICAL EDUCATION
VIJAYAWADA)

<i>Commerce</i>	<i>CRC-506 CE G/C</i>	<i>2021-2022</i>	<i>III.B.Com(gen)</i>
-----------------	-----------------------	------------------	-----------------------

SEMESTER –V

Guidelines to the paper setter

Rural and Farm Credit

Marks	UNIT-I	UNIT-II	UNIT-III	UNIT-IV	UNIT-V
	Rural Credit	Rural Credit Agencies	Farm Credit	Sources of Farm Credit	Farm Credit Analysis
5Marks	1	1	1	0	1
15Marks	2	2	1	2	1
Weight age	35	35	20	30	20

**A.G& S.G.SIDDHARTHA DEGREE COLLEGE OF ARTS &
SCIENCE**

VUYYURU-521165, KRISHNA Dt., A.P.(Autonomous)

Accredited by NAAC with "A" Grade

2021-2022



DEPARTMENT OF COMMERCE

MINUTES OF BOARD OF STUDIES





EVEN SEMESTER





31-03-2022

Minutes of the meeting of Board of studies in Commerce for the Autonomous courses of
AG & SG Siddhartha Degree College of Arts & Science, Vuyyuru, held at
10.30 A.M on 31-3-2022

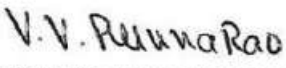
N.Vasanatha Rao ... Presiding

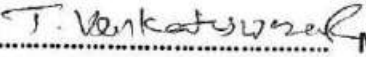
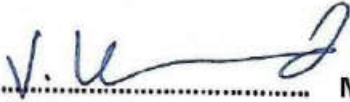
Members Present:

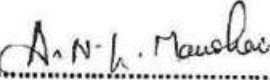
- 1).....
(N.Vasanatha Rao) Chairman Head, Department of Commerce
AG & SG S Degree College of Arts & Science
Vuyyuru
- 2).....
(Dr.N.A Francis Xavier) University Nominee Head, Department of Commerce
Andhra Loyola College.
Vijayawada (9440524321)
nafrancisxavier@gmail.com
- 3).....
(Dr.K.Venkateswarlu,) Subject Expert Lecturer in Commerce
V.S.R Govt. Degree & P.G College
Movva (9848341412)
gdcjkc.movva@gmail.com
- 4).....
(K.Narayanarao) Subject Expert Lecturer in Commerce
P.B.Siddhartha College of arts and Science
Vijayawada. (9885038196)
hodcommerce@pbsiddhartha.ac.in
- 5).....
(Sri V.Punnarao) Member General Manager
K.C.P & IC Ltd
Vuyyuru.
- 6).....
(Sri V.Balaji) Member Chartered Accountant
Managing Partner
Balaji V & Co (9052190007)
Vuyyuru (cbalajinco@gmail.com)

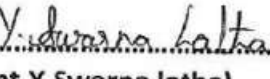
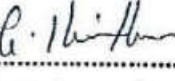
- 7)  Member
(Dr. T. Venkateswara Rao) Lecturer in Commerce
AG & SG S Degree College of Arts & Science
Vuyyuru
- 8)  Member
(Sri V. Gopi Chand) Lecturer in Commerce
AG & SG S Degree College of Arts & Science
Vuyyuru
- 9)  Member
(Sri K. Sekhar Babu) Lecturer in Commerce
AG & SG S Degree College of Arts & Science
Vuyyuru
- 10)  Member
(Ms A.N.L Manohari) Lecturer in Commerce
AG & SG S Degree College of Arts & Science
Vuyyuru
- 11)  Member
(Ms P. Mohan Krishna) Lecturer in Commerce
AG & SG S Degree College of Arts & Science
Vuyyuru
- 12)  Member
(Smt. Y. Swarna Latha) Lecturer in Commerce
AG & SG S Degree College of Arts & Science
Vuyyuru
- 13)  Member
(K. Kiran Kumar) Lecturer in Commerce
AG & SG S Degree College of Arts & Science
Vuyyuru

RESOLUTIONS

1. Discussed and recommended the Changed syllabi, Model Question Papers and Guidelines for question paper setters in Commerce for the 2nd Semester of **I B.Com., (general, computer & e-commerce)** for the Academic year 2021-2022 prescribed by APSCHE. A new Topic “**Supply analysis**” was incorporated in Unit II. Some new topics “**Monopolistic Competition, Oligopoly and Kinky demand curve Analysis**” was incorporated in Unit IV and another new topic “**Trade cycles**” was incorporated in Unit V of Business Economics.
2. Discussed and recommended that no changes are required in syllabi, Model Question Papers and Guidelines for question paper setters in Commerce for the 4th Semester of **II B.Com., (general & computer)** for the Academic year 2021-2022.
3. Discussed and recommended that no changes are required in syllabi, but some minor changes are required in Model Question Papers and Guidelines for question paper setters in Commerce for the 6th Semester of **III B.Com., (general & computer)** for the Academic year 2021-2022.
4. It is resolved to continue the same blue prints of II, IV, & VI Semesters of Degree B.Com(**general & computer**) for the Academic year 2021-2022.
5. It is resolved to continue following Teaching and Evaluation methods for Academic year 2022-2023.

Teaching methods:

Besides the conventional methods of teaching, we use modern technology i.e. using of LCD projector, display on U boards etc, for better understanding of concepts.

Evaluation of a student is done by the following procedure:

Internal Assessment (IA) I B.Com (General, Computers & e-Commerce)

- Out of maximum 100 marks in each paper 25 marks shall be allocated for internal assessment for I.B.Com (General, Computers & e-Commerce). Out of these 25 marks, 20 Marks are allocated for announced tests (i.e. IA-1 & IA-2). Two announced tests will be conducted and average of these two tests shall be deemed as the marks obtained by the student, and remaining 5 marks are allocated for the assignment. There is no minimum passing for IA.

Internal Assessment (IA) II & III B.Com (General & Computers)

- Out of maximum 100 marks in each paper 30 marks shall be allocated for internal assessment B.Com (General & Computers). Out of these 30 marks, 20 Marks are allocated for announced tests (i.e. IA-1 & IA-2). Two announced tests will be conducted and average of these two tests shall be deemed as the marks obtained by the student, 5 marks allocated on the basis of candidate's percentage of attendance and remaining 5 marks are allocated for the assignment. There is no minimum passing for IA.

Semester Examinations (SE)

- The Semester Examinations will be in the form of a comprehensive examination covering the entire syllabus in each subject. It will be of 3 hours duration, with maximum 70 marks, irrespective of the number of credits allotted to it.
 - Even though the candidate is absent for two IA exams/obtained zero marks, the external marks are considered (if he/she gets 40/70) and the result shall be declared as 'PASS'
 - The pass mark shall be 30 out of 75 in the Semester end examination for I B.Com (General ,Computers & e-Commerce)
 - The pass mark shall be 28 out of 70 in the Semester end examination for II& III.B.Com and (General & Computers)
 - The maximum marks for each Paper shall be 100.(Internal 30 + External 70)
6. Discussed and recommended to organize certificate course online/offline, seminars, Guest lectures, Online Examinations and Workshops to upgrade the knowledge of students for Competitive Examinations for the approval of the Academic Council.
7. It is resolved to follow further changes if any in the Syllabus by the Competent Authority

Chairman

Programme Specific Outcomes (PSO)

PSO1. Getting the knowledge and the importance of accounting and auditing Standards for the reliability of financial statements.

PSO2 Interpret the legal and environmental aspects of business and Analyze quantitative data in order to take business decisions

PSO3. Empowering the student to understand the accounting practices and Procedures followed by different business entities.

PSO4. Promising the Practical skills for a bright career as accounting officers, computer professionals, audit assistants, businessmen, entrepreneurs, managers with required knowledge in computers.

PSO5. Knowledge of major theories and models in key areas which motivate them to pursue higher studies / face competitive exams like SSC,P.C,BANK,R.R.B/ professional courses like CA,CS, ICWA and other courses.

Program outcomes (Pos)

PO1. Critical Thinking: Knowledgeable in the core disciplines of Commerce, Economics and Business through a number of specializations and practical exposure enables them to face the challenges in the field of Commerce

PO2. Effective Communication: Demonstrate proficiency in communicating competently in groups and organizations in English and in one Indian language,

PO3. Effective Citizenship: Ability to act with an informed awareness of issues and participate in civic life through volunteering.

PO4. Value- based development: Recognize values such as justice, trust, equity, fairness, kindness and, understand the moral Dimensions of your decisions, and accept responsibility for them.

PO5. Environment and Sustainability: Understand the issues of environmental contexts and Sustainable development.

PO6. Self-directed and Life-long Learning: promoting continuous development and improvement of the knowledge and skills needed for employment and personal fulfillment

SEMESTER- II

Course Code	Title of the Course	Instruction Hours per week	Credits	Evaluation		
				CIA MARKS	SEE	
					MARKS	DURATION
COMT21A	Financial Accounting(Gen , CA & EC)	5	4	25	75	3 Hrs.
ECOT22B	BUSINESS ECONOMICS (Gen , CA)	5	4	25	75	3 Hrs.
COMT22B	Banking Theory &Practice (Gen)	5	4	25	75	3 Hrs.
CAD 201G/C	Advertising (Gen, CA & E-Com)	2	2	10	40	2Hrs

SEMESTER- IV

Course Code	Title of the Course	Instruction Hours per week	Credits	Evaluation		
				CIA MARKS	SEE	
					MARKS	DURATION
CCA-401 G/C	Corporate Accounting (Gen & CA)	5	4	30	70	3 Hrs.
CCMA-402G/C	Cost and Management Accounting (Gen & CA)	5	4	30	70	3 Hrs.
CIT-403G/C	Income Tax (Gen & CA)	5	4	30	70	3 Hrs.
CBL-404G/C	Business Laws (Gen & CA)	5	4	30	70	3 Hrs.
CAUD-405G	Auditing (Gen)	5	4	30	70	3 Hrs.
CGST-406 G	Goods and Service Tax (Gen)	5	4	30	70	3 Hrs.

SEMESTER – VI

Course Code	Title of the Course	Instruction Hours per week	Credits	Evaluation		
				CIA MARKS	SEE	
					MARKS	DURATION
CEM-601 G/C C	Event Management	2	2		50	2 Hrs.
CM-602GEG/C C	Marketing	5	4	30	70	3 Hrs.
CAU-603GE G/C C	Auditing	5	4	30	70	3 Hrs.
CMA 604GE G/C C	Management Accounting	5	4	30	70	3 Hrs.
CFS 605 CE G/C	Financial Services	5	4	30	70	3Hrs
CMFS 606 CE G/C	Marketing of Financial Services	5	4	30	70	3Hrs
COM 607P	Project	3	4	--	100	--



A. G & S.G. SIDDHARTHA DEGREE COLLEGE OF ARTS & SCIENCE

Vuyyuru-521165.

NAAC reaccredited at 'A' level
Autonomous -ISO 9001 – 2015 Certified

TITLE OF THE PAPER: Financial Accounting
Semester: II

Course Code	COMT21A	Course Delivery Method	Class Room / Blended Mode - Both
Credits	4	CIA Marks	25
No. of Lecture Hours / Week	5	Semester End Exam Marks	75
Total Number of Lecture Hours	75	Total Marks	100
Year of Introduction:	Year of Offering: 2021 - 22	Year of Revision: ---	Percentage of Revision: 0%
CLASS:	I.B.COM., (gen/computer/e-commerce)		

COURSE OUTCOMES:

CO1 Determine the useful life and value of the depreciable assets. and maintenance of Reserves in business entities.

CO2 Demonstrate the applicability of the concept of Provisions and reserves to understand the managerial Decisions and financial statements

CO3 Appreciate the need for negotiable instruments and procedure of accounting for bills honored and dishonored

CO4 Understand the concept of Consignment and learn the accounting treatment of the various aspects of consignment

CO5 Distinguish Joint Venture and Partnership and to learn the methods of maintaining records under Joint Venture

Learning Objective:

1. This course will enable the students to combine practice and theoretical knowledge of financial accounting.
2. The students of this course will be active learners and develop awareness of emerging trends in financial accounting,
3. The course will provide decision making skills to the students in the financial analysis context,
4. The students of this course will have the ability to identify and analyze financial accounting problems and opportunities in real life situations.

Syllabus Financial Accounting

Course Details

Unit	Learning Units	Lecture Hours
I	Depreciation: Meaning and Causes of Depreciation - Methods of Depreciation: Straight Line – Written Down Value – Annuity and Depletion Method (including Problems).	15
II	Provisions and Reserves: Meaning – Provision vs. Reserve – Preparation of Bad Debts Account – Provision for Bad and Doubtful Debts – Provision for Discount on Debtors – Provision for Discount on Creditors - Repairs and Renewals Reserve A/c (including Problems).	15
III	Bills of Exchange: Meaning of Bill – Features of Bill – Parties in the Bill – Discounting of Bill – Renewal of Bill – Entries in the Books of Drawer and Drawee (including Problems).	15
IV	Consignment Accounts: Consignment - Features - Proforma Invoice - Account Sales – Del-credere Commission - Accounting Treatment in the Books of Consigner and Consignee - Valuation of Closing Stock - Normal and Abnormal Losses (including Problems).	15
V	Joint Venture Accounts: Joint Venture - Features - Difference between Joint Venture and Consignment – Accounting Procedure – Methods of Keeping Records– One Vendor Keeps the Accounts and Separate Set off Books Methods (including Problems).	15

Test Book Prefer:

1. Financial Accounting By: S.P.Jain& K.L. Narang. Kalyani Publishers – New Delhi.

Reference text books:

1. Financial Accounting – Himalaya Publishers
2. Financial Accounting – Pragthiprakesh Publishers

Suggested Co-Curricular Activities:

1. Quiz Programs
2. Problem Solving Exercises
3. Seminar
4. Group Discussions on problems relating to topics covered by syllabus
5. Collection of proforma of bills and promissory notes
6. Examinations (Scheduled and surprise test)

Web Links:

1. <https://www.vedantu.com/commerce/difference-between-provision-and-reserve>
2. <https://youtu.be/BYYR9wp2maY>
3. <https://youtu.be/L1ex2P4NNiA>
4. <https://youtu.be/IYihGJ5nhQ0>



A.G. & S.G. SIDDHARTHA DEGREE COLLEGE OF ARTS & SCIENCE

Vuyyuru-521165.

NAAC reaccredited at 'A' level

Autonomous -ISO 9001 – 2015 Certified

TITLE OF THE PAPER: Financial Accounting

Semester: II

Time: 3Hrs

Max.Marks:75

SECTION- A

Answer any FIVE of the following.

5 x 5 = 25.

1. Explain the meaning and causes of depreciation. **CO1,L2**
2. What are the factors effecting the amount of depreciation? **CO1,L1**
3. What are the differences between Reserve and Provisions? **CO2,L1**
4. What is bill? Explain the types of bills. **CO3,L1**
5. Explain the features of Consignment. **CO4,L2**
6. Performa Invoice and Account Sales **CO4,L2**
7. Explain the essential features of Joint Venture. **CO5,L2**
8. What is Memorandum Joint Venture Account? **CO5,L1**

SECTION- B

Answer ALL the following questions.

5 x 10 = 50

9. A. Explain the different methods of depreciation. **CO1,L2**

Or

B. A company whose accounting year is the calendar year, purchased on 1st April 2011 machinery costing rs. 30,000. It purchased further machinery on 1st October 2011 costing rs. 20,000 and on 1st July 2012 costing rs. 30,000. On 1st January 2013 1/3 of the machinery installed on 1st April 2011 become obsolete and was sold for rs. 3,000.

Show how machinery account would appear in the books of the company, it being given that machinery was depreciated by Fixed Installment Method at 10% p.a. **CO1,L3**

10. A. What is meant by Reserve? What are the different types of Reserves? **CO2,L1**

Or

B) A firm desires to debit its profit and loss account with a uniform figure every year in respect of repairs and renewals. In created a repairs and renewals provision by charing Rs 30000 every year. Actual repairs were Rs. 3000 in second year and Rs 8000 in second year, Rs 11000 in the third year. Show the repairs and renewal provision account for three years. **CO2,L3**

11. A) What are the difference between promissory note and Bills of Exchange? **CO3,L1**

Or

B. Jagannadh purchases goods worth Rs. 15,000 from Viswanath on 1-1-15. Viswanath draws a bill on jagannadh for Rs. 15,000 for 4 months, which is accepted by jagannadh. Viswanadh discounts the same for Rs. 14,900. On maturity Jagannadh fails to honour the bill and requests Viswanadh to draw a new bill for 3 months for the original amount plus interest at 10% per annum plus discounting charges of the original bill. Viswanadh agrees to the proposal. Make Journal entries in the books of Viswanadh ledger accounts in the books of Jagannadh. **CO3,L3**

12. A) What is Consignment? Explain the difference between Consignment and Sale. **CO4,L1**

Or

B. On 1st Jan, 2015 B of Mumbai consigned 100 cases (cost price Rs. 7, 500) at a proforma invoice of 25% profit on sale to his agent C of Chandigarh. On the same date B paid Rs. 600 as expenses. On 30th Jan, C took delivery and paid Rs. 1,200 for octroi and other duties and remitted Rs. 4,000 as an advance. On 31st Jan he sold 80 cases for Rs. 10,500; C is entitled to 5% commission on gross sales and 10% of the price in excess of invoice price. Show Consignment A/c and C's A/c in the books of B. **CO4,L3**

13. A. What is Joint Venture? What are the different methods for recording Joint Venture transactions? **CO5,L1**

Or

B. Jolly and Happy undertake jointly to construct a building for Hyderabad insurance Co. Ltd., for contract price of Rs. 9,00,000 payable as to Rs. 7,20,000 by instalments in cash and Rs. 1,80,000 in fully paid shares of the company. A Joint Bank Account is opened in their names, jolly paying in Rs. 2,25,000 and Happy Rs. 1,35,000. They are to share Profit of Loss in the proportion of 2/3 and 1/3 respectively. Their transactions were as follows

	Rs.
Paid wages	2,70,000
Bought materials	6,30,000
Materials supplied by Jolly from his stock	45,000
Materials supplied by Happy from his stock	36,000
Architect's Fees paid by Jolly	18,000

The contract was completed and the Price duly received. The joint venture was closed by Jolly taking up all the shares of the company at an agreed valuation of Rs. 1,44,000 and Happy taking up the stock of materials at an agreed valuation of Rs. 27,000.

Prepare the Joint Venture Account and the accounts of Jolly and Happy, showing the final distribution of cash. **CO5,L3**

@@@@



A. G & S.G. SIDDHARTHA DEGREE COLLEGE OF ARTS & SCIENCE

Vuyyuru-521165.

NAAC reaccredited at 'A' level
Autonomous -ISO 9001 – 2015 Certified

TITLE OF THE PAPER: BUSINESS ECONOMICS
Semester: II

Course Code	ECOT22B	Course Delivery Method	Class Room / Blended Mode - Both
Credits	4	CIA Marks	25
No. of Lecture Hours / Week	5	Semester End Exam Marks	75
Total Number of Lecture Hours	75	Total Marks	100
Year of Introduction:	Year of Offering: 2012-13	Year of Revision: 2021-22	Percentage of Revision: 20%
CLASS:	I.B.COM., (gen/computer)		

Course objectives:

- Co1 Students are able to acquire the knowledge about definition , nature and scope of business economics
- Co2 Students are able to acquire the knowledge about demand and supply analysis
- Co3 Students are able to acquire the knowledge about production cost and revenue analysis
- Co4 Students are able to acquire the knowledge about different market structures
- Co5 Students are able to acquire the knowledge about national income and trade cycles

Syllabus
BUSINESS ECONOMICS

Course Details

Unit	Learning Units	Lecture Hours
I	INTRODUCTION : Meaning and Definition of Economics Wealth Definition Welfare Definition Scarcity Definition Meaning and Definition of Business Economics Nature and Scope of Business Economics Micro Economics and Macro Economics	15
II	DEMAND AND SUPPLY ANALYSIS : Meaning and Definition of demand Determinants of Demand – Demand Function Law of Demand – Demand curve – exceptions Elasticity of Demand Types of Price Elasticity of Demand Methods to measure Price Elasticity of Demand Law of Supply-Exceptions to the Law	15
III	PRODUCTION, COST AND REVENUE ANALYSIS : Production Analysis – Production Function – Meaning The law of variable proportions The law of Returns to Scale Cost Analysis: Short Run Cost Curves Relationship between AC & MC Curves Revenue Analysis: Revenue Concepts & Revenue curves Meaning of Breakeven point & Breakeven chart	15
IV	MARKET STRUCTURES: Classification of markets Features of Perfect competition Price determination under perfect competition Features of Monopoly market Features of monopolistic competition market Features of Oligopoly market Kinky Demand Curve analysis	15
V	NATIONAL INCOME AND TRADE CYCLES : National Income Meaning and Definition of National Income (Marshall, Pigou, Fisher) Concepts of National Income – GDP, GNP, NDP, NMP, NNPF, PI, DI, PCI, RNI, RPCI National Income Measurement (Product, Income & Expenditure Methods) Problems in measuring National Income Trade Cycles Meaning and Definition of Trade cycles Phases of Trade Cycles Causes for Trade Cycles Controlling Measures of Trade Cycles	15

Text Books :

Business Economics – A.V. Ranganadhachary – Kalyani Publishers
Business Economics – Telugu Academy

Reference Books:

H.L. AHUJA – Business Economics – S.Chand & Company Publishers
P.N. CHOPRA – Business Economics – Kalyani Publishers
D.M. MITHANI-Fundamentals of Business Economics-Himalaya Publishers
DEEPASHREE – General Economics – Tata Mc. GrawHills

Revision of the syllabus 2021-22 (2,4,6)

Semester -II

Name of the Subject: **Business Economics**

Subject Code: CBE202G/C

Academic Year	2021-22
Title of the paper	Business Economics
Semester	II
Course code	CBE202G/C
CIA marks	30
Semester End marks	70
Total marks	100
Year of Introduction	2012-13
Year of Revision	2021-2022
% of revision	20%

UNIT	Syllabus	Addition	Deletion
I	INTRODUCTION: Meaning and Definition of Economics Wealth Definition Welfare Definition Scarcity Definition Meaning and Definition of Business Economics Nature and Scope of Business Economics Micro Economics and Macro Economics	Nil	Nil
II	DEMAND AND SUPPLY ANALYSIS Meaning and Definition of demand Determinants of Demand – Demand Function Law of Demand – Demand curve – exceptions Elasticity of Demand Types of Price Elasticity of Demand Methods to measure Price Elasticity of Demand Law of Supply-Exceptions to the Law	Law of Supply-Exceptions to the Law	Nil
III	PRODUCTION, COST AND REVENUE ANALYSIS :Production Analysis – Production Function – Meaning The law of variable proportions The law of Returns to Scale Cost Analysis: Short Run Cost Curves Relationship between AC & MC Curves Revenue Analysis:	Nil	Nil

	Revenue Concepts & Revenue curve Meaning of Breakeven point & Breakeven chart		
IV	MARKET STRUCTURES: Classification of markets Features of Perfect competition Price determination under perfect competition Features of Monopoly market Features of monopolistic competition market Features of Oligopoly market Kinky Demand Curve analysis	Monopolistic competition market Features of Oligopoly market Kinky Demand Curve analysis	Nil
V	NATIONAL INCOME AND TRADE CYCLES : National Income Meaning and Definition of National Income (Marshall, Pigou, Fisher) Concepts of National Income – GDP, GNP, NDP, NMP, NNPF, PI, DI, PCI, RNI, RPCI National Income Measurement (Product, Income & Expenditure Methods) Problems in measuring National Income - Trade Cycles Meaning and Definition of Trade cycles Phases of Trade Cycles Causes for Trade Cycles Controlling Measures of Trade Cycles.	Trade Cycles Meaning and Definition of Trade cycles Phases of Trade Cycles Causes for Trade Cycles Controlling Measures of Trade Cycles	Nil



**A. G & S.G. SIDDHARTHA DEGREE COLLEGE OF ARTS &
SCIENCE**

Vuyyuru-521165.

NAAC recredited at 'A' level
Autonomous -ISO 9001 – 2015 Certified

TITLE OF THE PAPER: BUSINESS ECONOMICS
Semester: II

Section -A

Answer FIVE of the following

5x5=25M

- | | |
|--|----------------|
| 1. Robbins Scarcity definition to economics. | L ₁ |
| 2. Exceptions to the law of demand | L ₂ |
| 3. Explain the law of supply | L ₁ |
| 4. Law of returns to sale | L ₁ |
| 5. Break evenpoint | L ₃ |
| 6. Explain the classification of markets | L ₂ |
| 7. Features of monopoly market | L ₁ |
| 8. Controlling measures of business cycles | L ₂ |

Section -B

Answer the following

5x10=50M

- | | |
|---|----------------|
| 9. a). Explain the Nature and Scope of Business economics | L ₁ |
| (or) | |
| b) Distinguish between micro and macroeconomics | L ₂ |
| 10. a) Explain the various types of price elasticity of demand | L ₃ |
| (or) | |
| b) Discuss the various methods to measure price elasticity of demand. | L ₃ |
| 11. a) Explain the law of variable proportions | L ₂ |
| (or) | |
| b) Explain the relationship between different short run cost curves. | L ₃ |
| 12. a) Explain the price determination under perfect competition. | L ₂ |
| (or) | |
| b) Explain the Kinky demand curve analysis | L ₃ |
| 13. a) Define National income and explain the various methods of measuring national income. | L ₁ |
| (or) | |
| b) Define trade cycles and explain the various phases of trade cycles. | L ₃ |



**A. G & S.G. SIDDHARTHA DEGREE COLLEGE OF ARTS &
SCIENCE**

Vuyyuru-521165.

NAAC re accredited at 'A' level
Autonomous -ISO 9001 – 2015 Certified

TITLE OF THE PAPER: Banking Theory & Practice
Semester: II

Course Code	COMT22B	Course Delivery Method	Class Room / Blended Mode - Both
Credits	4	CIA Marks	25
No. of Lecture Hours / Week	5	Semester End Exam Marks	75
Total Number of Lecture Hours	75	Total Marks	100
Year of Introduction:	Year of Offering: 2021 - 22	Year of Revision: ---	Percentage of Revision: 0%
CLASS:	II.B.COM., (gen)		

Course objectives:

The course will enable students to:

1. Introduce the students to the basic concepts of banking as a financial disintermediation service.
2. Discuss and evaluate the theories relating to the role of banks as financial intermediaries.
3. Describe and analyse the various bank performance measures.

Course Outcomes:

At the end of the course, the student will able to:

- CO1.** Understand the basic concepts of banks and functions of commercial banks.
- CO2.** Demonstrate an awareness of law and practice in a banking context.
- CO3.** Engage in critical analysis of the practice of banking law.
- CO4.** Organize information as it relates to the regulation of banking products and services.
- CO5.** Formulate the procedure for better service to the customers from various banking innovations.

Syllabus
Banking Theory & Practice

Course Details

Unit	Learning Units	Lecture Hours
I	Introduction: Meaning & Definition of Bank – Functions of Commercial Banks – Credit Creation with Examples - Kinds of Banks – Central Banking Vs. Commercial Banking.	15
II	Banking Systems: Unit Banking, Branch Banking, Investment Banking - Innovations in Banking – E banking -Online and Offshore Banking, Internet Banking - Anywhere Banking - ATMs – RTGS-NEFT – Mobile Banking	15
III	Types of Banks: Indigenous Banking - Cooperative Banks, Regional Rural Banks, SIDBI, NABARD - EXIM bank	15
IV	Banker and Customer: Meaning and Definition of Banker and Customer – Types of Customers – General Relationship and Special Relationship between Banker and Customer – KYC Norms.	15
V	Collecting Banker and Paying Banker: □ Concepts - Duties & Responsibilities of Collecting Banker – Holder for Value – Holder in Due Course – Statutory Protection to Collecting Banker - Responsibilities of Paying Banker -Payment gateways.	15

Text Book:

Banking theory law and practice - Himalaya publishing House

Reference books:

1. Banking theory and practice - Himalaya publishing house
2. Banking - New age international publishers
3. Banking theory and practice- kalyani publishers

Curricular and co- curricular activities:

1. Debate
2. Student seminars
3. Quiz programs
4. Visit to bank premises
5. Know about KYC norms

Practical Work/suggested activities:

1. filling of Bank account opening form
2. filling of RTGS form
3. Filling of NEFT form
4. filling of cheque form

**A.G& S.G.SIDDHARTHA DEGREE COLLEGE OF ARTS &
SCIENCE**

Vuyyuru-521165.

NAAC recredited at 'A' level
Autonomous -ISO 9001 – 2015 Certified

TITLE OF THE PAPER: Banking Theory & Practice

Semester: II

Time: 3Hrs

Max.Marks:75

SECTION- A

Answer Any FIVE Of The Following.

5X5=25

1. Types of deposits (CO1) (L4)
2. Discuss the signification of KYC to bank. (CO2), (L2)
3. SIDIBI (CO3) (L2)
4. Indigenous bankers (CO3) (L2)
5. ATMs (CO2) (L2)
6. Holders for value (CO5) (L2)
7. Investments banking (CO2) (L2)
8. What precaution a banker take in opening the accounts of a minor? (CO4) (L1)

SECTION-B

Answer the following .

5X10=50

9.a. Define commercial Bank. Discuss the functions of a commercial Bank. (CO1) (L1)

OR

b. Explain the difference between Central Bank and Commercial Bank. (CO1) (L2)

10.a. Define Branch Banking. Discuss its advantages and disadvantages. (CO2) (L1)

OR

b. Discuss the E-banking .Explain advantages of E- banking. (CO2) (L2)

11.a. Define Regional Rural Bank. Briefly explain the functions of RRB. (CO3) (L1)

OR

b. Explain in brief about the functions of NABARD. (CO3) (L2)

12.a. Explain briefly the general relationship between banker and customer. (CO4) (L2)

OR

b. Explain the right of lien of banker. How and when it is exercised. (CO4) (L2)

13.a. Define paying Banker. Discuss the responsibilities and duties of paying Banker. (CO5) (L1)

OR

b. Define Collecting Banker. What are the duties and legal protection of Collecting Banker?
(CO5) (L1)

@@@@@@@@



SIDDHARTHA DEGREE COLLEGE OF ARTS & SCIENCE

**Vuyyuru-
521165.NAAC**

reaccredited at 'A' level

Autonomous-ISO9001 –2015 Certified

TITLE OF THE PAPER: ADVERTISING

Semester: II

Course Code	CAD201G/C	Course Delivery Method	Class Room/Blended Mode - Both
Credits	2	CIA Marks	10
No. of Lecture Hours/Week	2	Semester End Exam Marks	40
Total Number of Lecture Hours	30	Total Marks	50
Year of Introduction:	Year of Offering: 2021-22	Year of Revision: ---	Percentage of Revision: 0%
CLASS:	IB.COM., (gen, computer & e-com)		

Learning Outcomes: After successful completion of this course, the students are able to:

1. Understand the field of Advertising
 2. Comprehend opportunities and challenges in Advertising sector
 3. Prepare a primary advertising model
 4. Understand applying of related skills
 5. Examine the scope for making advertising a future career
- Syllabus

AG & SGG SIDDHARTHA DEGREE COLLEGE OF ARTS & SCIENCE VUYYURU

(AUTONOMOUS)

(MANAGED BY SIDDHARTHA ACADEMY OF GENERAL & TECHNICAL EDUCATION VIJAYAWADA)

<i>Commerce</i>	CAD201G/C	<i>2022-2023</i>	<i>I.B. Com(Gen, comp & e-com)</i>
SEMESTER-II	ADVERTISING		

Skill Development Course

Total 30 hrs (2 hrs/wk) credits 02

Maximum 50 Marks

UNIT I: 06hrs Introduction of advertising concepts- functions - Types of advertising - Creative advertising messages - Factors determining opportunities of a product/service/Idea

UNIT II: 10 hrs Role of advertising agencies and their responsibilities - scope of their work and functions - Ethical issues - Identifying target groups - Laws in advertising. Advertising Statutory Bodies in India - Role of AAAI (Advertising Agencies Association of India), ASCI (Advertising Standard Council of India)

UNIT III: 10hrs Types of advertising – Basic characteristics of a typical advertisement – Reaching target groups-Local advertising–Feedback on impact of advertisement -Business promotion.

Recommended Co-curricular Activities(04hrs):

1. Collection and segmentation of advertisements
2. Invited Lectures/skill training on local advertising basics and skills
3. Visit to local advertising agency
4. Model creation of advertisements in compliance with legal rules
5. Assignments, Group discussion, Quiz etc

Reference books and Websites:

1. Bhatia. K. Tej- Advertising and Marketing in Rural India - Mc Millan India

AG & SGSIDDHARTHADEGREE COLLEGE OF ARTS & SCIENCE VUYYURU

(AUTONOMOUS)

**(MANAGED BY SIDDHARTHA ACADEMY OF GENERAL & TECHNICAL
EDUCATION VIJAYAWADA)**

Commerce	CAD201G/C	2021-2022	I.B.Com(Gen,comp&e-com)
----------	-----------	-----------	-------------------------

SEMESTER-II

ADVERTISING

Model Paper

Skill Development Course

DURATION: 2 HOURS

SECTION - A Max: 40

ANSWER ANY TWO OF THE FOLLOWING QUESTIONS

(2X5=10M)

1. Define Advertising
2. Describe the Functions of Advertising
3. Explain the role of advertising agencies
4. Advertising and Ethical issues

SECTION - B

ANSWER ANY THREE OF THE FOLLOWING QUESTIONS

(3x10=30M)

5. What are the factors determining opportunities of a product or an idea
6. What are the advertising statutory bodies in India
7. Write types of advertising
8. What are the basic Characteristics of advertising Local advertising
9. Write about Business promotion
10. What are the basic Characteristics of advertising



A. G & S.G. SIDDHARTHA DEGREE COLLEGE OF ARTS & SCIENCE

Vuyyuru-521165.

NAAC re accredited at 'A' level

Autonomous -ISO 9001 – 2015 Certified

TITLE OF THE PAPER: Corporate Accounting

Semester: IV

Course Code	CCA-401 G/C	Course Delivery Method	Class Room / Blended Mode - Both
Credits	4	CIA Marks	30
No. of Lecture Hours / Week	5	Semester End Exam Marks	70
Total Number of Lecture Hours	75	Total Marks	100
Year of Introduction:	Year of Offering: 2021 22	Year of Revision: ---	Percentage of Revision: 0%
CLASS:	II.B.COM., (gen/computer)		

Learning Outcomes:

At the end of the course, the student will able to

- ❖ Understand the Accounting treatment of Share Capital and aware of process of book building.
- ❖ Demonstrate the procedure for issue of bonus shares and buyback of shares.
- ❖ Comprehend the important provisions of Companies Act, 2013 and prepare final accounts of a company with Adjustments
- ❖ Participate in the preparation of consolidated accounts for a corporate group.
- ❖ Understand analysis of complex issues, formulation of well-reasoned arguments and reaching better conclusions
- ❖ Communicate accounting policy choices with reference to relevant laws and accounting standards.

Syllabus Corporate Accounting

Course Details

Unit	Learning Units	Lecture Hours
I	Accounting for Share Capital: Kinds of Shares – Types of Preference Shares – Issue of Shares at Par, Discount and Premium - Forfeiture and Reissue of Shares (including problems)	15
II	Issue and Redemption of Debentures and Issue of Bonus Shares: Accounting Treatment for Debentures Issued and Repayable at Par, Discount and Premium - Issue of Bonus Shares - Buyback of Shares - (including problems).	15
III	Valuation of Goodwill: Need and Methods - Average Profit Method, Super Profits Method – Capitalization Method and Annuity Method (Including problems).	15
IV	Valuation Shares: Need for Valuation - Methods of Valuation - Net Assets Method, Yield Basis Method, Fair Value Method (including problems).	15
V	Company Final Accounts: Provisions of the Companies Act, 2013 - Preparation of Final Accounts – Adjustments Relating to Preparation of Final Accounts – Profit and Loss Account and Balance Sheet – (including problems with simple adjustments).	15

Reference Books:

1. Corporate Accounting – T.S Reddy and Murthy, Margham Publications, Chennai.
2. Advanced Accounts: M C Shukla, T S Grewal and S C Gupta, S Chand Publications
3. Corporate Accounting – Haneef&Mukherji, Tata McGraw Hill Publications.
4. Corporate Accounting – RL Gupta & Radha Swami, Sultan Chand & sons

Co-Curricular Activities:

- Assignments
- Problem Solving Exercises
- Collect and fill the share application form of a limited Company
- Collect Prospectus of a company and identify its salient features
- Collect annual report of a Company and List out its assets and Liabilities.
- Collect the annual reports of company and calculate the value of goodwill under different methods
- Power point presentations on types of shares and share capital
- Group Discussions on problems relating to topics covered by syllabus



**A. G & S.G. SIDDHARTHA DEGREE COLLEGE
OF ARTS & SCIENCE**

Vuyyuru-521165.

NAAC reaccredited at 'A' level

Autonomous -ISO 9001 – 2015 Certified

TITLE OF THE PAPER: Corporate Accounting
Semester: IVMODEL PAPER

TIME -3hrs

SECTION-A

Max. Marks: 70

Answer any Two of the following

2x5=10M

1. Define Share and Explain different types of shares?
2. Explain different types of Debentures
3. Explain methods of Valuation of Goodwill
4. What is need for valuation of shares

Section-B

Answer any FOUR of the following 4x15=60M

5. What are Preference Share Explain different types of Preference Shares?
6. Write difference between Shares and Debentures
7. Write about provision of Companies Act 2013.
8. XYZ company limited issued 5000 equity shares of 20/- each. The amount was payable as follows

:

On Application Rs.5

On Allotment Rs.5

On First call Rs.6

On Final call Rs.4

X to whom 250 shares were allotted. He failed to pay his first call money. The remaining money was duly received. Pass journal entries in the books of the company.

9. Journalise the following transactions at the time of issue and redemption of debentures.

- i. A debenture was issued at Rs.100 and repayable at Rs.100.
- ii. A debenture was issued at Rs.95 and repayable at Rs.100.
- iii. A debenture was issued at Rs.110 and repayable at Rs.100.
- iv. A debenture was issued at Rs.100 and repayable at Rs.105.
- v. A debenture was issued at Rs.95 and repayable at Rs.110

10. A business concern had earned profits for the past 3 years as follows

2007 –Rs50, 000 2008-Rs, 60, 000, 2009 –Rs70000.

Average capital employed in the business Rs.4, 00,000.

Reasonable rate of return expected in a similar business is 10%

From the above, calculate the value of goodwill under,

(a) 2 years purchase of the average profits of last three years

(b) four years purchase of super profits the basis of average profits of previous three years .

11. The Balance sheet of Deepak LTD. as on 31.03.2004 was as under.

Liabilities.	Rs.	Assets.	Rs.
4,000 Equity shares of Rs. 100 each	4,00,000	Land and buildings	
General Reserve		Machinery	2,50,000
Profit and loss Account	50,000	Investment at cost (market value Rs.60,000)	1,20,000
Creditors	50,000	Debtors	
Provision for taxation		Stock	70,000
	90,000	Cash at bank	
			100,000
	40,000		80,000
			10,000
	6,30,000		6,30,000

Additional Information:

(a) Land and Buildings and machinery are valued at Rs.2,40,000 and Rs.95,000

(b) Of the total debtors Rs.5, 000 are bad.

(c) Good will is to be taken at Rs.50, 000

(d) The normal rate of dividend declared by such type of companies is 15% on paid up capital

(e) The average rate of dividend declared and paid by this company is 20% on its paid up capital. Calculate fair value of equity shares/

12. The following Trial Balance has been extracted from the book of XYZLTD .ason31st march2001. You are required to prepare profit and loss Account and Balance sheet as on the date.

Debit Balance.	Rs.	Credit Balance	Rs.
Land and Buildings	34,000	Share capital	1,00,000
Furniture	6,000	General reserve	5,000
Plant &Machinery	15,000	10%debentures	40,000
Stock on 31 st March 2001	75,000	Sundry Creditors	4,000
Salaries	25,000	Gross profit	75,000
Debtors	10,000	Interest on investments	1,000
5% Investments	20,000	Profit and loss Account-1 ST April	35,000
Bank	5,000		
Advance Income tax	2,000		
Debentures interest	2,000		
Directors fee	7,000		
Rent ,rates and insurance	24,000		
Good will	35,000		
	2,60,000		2,60,000

1. Depreciate the following assets

Land and Buildings at 10% P.a. Plant and Machinery 8% P.a.

2.Provision for bad debts at6%.

3. The Director have recommended

(a) Transfer .Rs 3,000to General Reserve Account.

(b)Eqity dividend at 10% on the paid up capital.

(c)Provision for income tax for Rs 4,000.



**A. G & S.G. SIDDHARTHA DEGREE COLLEGE
OF ARTS & SCIENCE**

Vuyyuru-521165.

NAAC reaccruited at 'A' level

Autonomous -ISO 9001 – 2015 Certified

TITLE OF THE PAPER:Corporate Accounting

Semester: IV

Guidelines to the paper setter

Marks	UNIT-I	UNIT-II	UNIT-III	UNIT-IV	UNIT-V
	Accounting for Share Capital: Kinds of Shares	Issue and Redemption of Debentures and Issue of Bonus Shares	Valuation of Goodwill	Valuation Shares	Promotion and Distribution
5Marks	1	1	1	1	–
15Marks	1T&1P	1T&1P	1P	1P	1T&1P
Weightage	35	35	20	20	30



A. G & S.G. SIDDHARTHA DEGREE COLLEGE OF ARTS & SCIENCE

Vuyyuru-521165.

NAAC reaccredited at 'A' level
Autonomous -ISO 9001 – 2015 Certified

TITLE OF THE PAPER: Cost and Management Accounting
Semester: IV

Course Code	CCMA-402G/C	Course Delivery Method	Class Room / Blended Mode - Both
Credits	4	CIA Marks	30
No. of Lecture Hours / Week	5	Semester End Exam Marks	70
Total Number of Lecture Hours	75	Total Marks	100
Year of Introduction:	Year of Offering: 2021 - 22	Year of Revision: ---	Percentage of Revision: 0%
CLASS:	II.B.COM., (gen/computer)		

Learning Outcomes:

At the end of the course, the student will able to

- ❖ Understand various costing methods and management techniques.
- ❖ Apply Cost and Management accounting methods for both manufacturing and service industry.
- ❖ Prepare cost sheet, quotations, and tenders to organization for different works.
- ❖ Analyze cost-volume-profit techniques to determine optimal managerial decisions.
- ❖ Compare and contrast the financial statements of firms and interpret the results.
- ❖ Prepare analysis of various special decisions, using relevant management techniques

Syllabus
Cost and Management Accounting

Course Details

Unit	Learning Units	Lecture Hours
I	Introduction: Cost Accounting: Definition – Features – Objectives – Functions – Scope – Advantages and Limitations - Management Accounting: Features – Objectives – Functions – Elements of Cost - Preparation of Cost Sheet (including problems)	15
II	Material and Labour Cost: Techniques of Inventory Control – Valuation of Material Issues: FIFO - LIFO - Simple and Weighted Average Methods Labour: Direct and Indirect Labour Cost – Methods of Payment of Wages- Incentive Schemes -Time Rate Method, Piece Rate Method, Halsey, Rowan Methods and Taylor Methods only(including problems)	15
III	Job Costing and Batch Costing: Definition and Features of Job Costing – Economic Batch Quantity (EBQ) – Preparation of Job Cost Sheet – Problems on Job Cost Sheet and Batch Costing(including problems)	15
IV	Financial Statement Analysis and Interpretation: Financial Statements - Features, Limitations. Need, Meaning, Objectives, and Process of Financial Statement Analysis- Comparative Analysis – Common Size Analysis and Trend Analysis (including problems)	15
V	Marginal Costing: Meaning and Features of Marginal Costing – Contribution – Profit Volume Ratio- Break Even Point – Margin of Safety – Estimation of Profit and Estimation of Sales(including problems)	15

References:

1. S.P. Jain and K.L. Narang – Advanced Cost Accounting, Kalyani Publishers.
2. M.N. Arora – A test book of Cost Accounting, Vikas Publishing House Pvt. Ltd.
3. S.P. Iyengar – Cost Accounting, Sultan Chand & Sons.
4. Nigam & Sharma – Cost Accounting Principles and Applications, S.Chand& Sons.
5. S.N. Maheswari– Principles of Management Accounting, Sultan Chand & Sons.

Co-Curricular Activities:

- ◆ Seminars
- ◆ Problem Solving Exercises
- ◆ Seminar on need and importance of financial statement analysis
- ◆ Graphs showing the breakeven point analysis
- ◆ Identification of elements of cost in services sector by Visiting any service firm
- ◆ Cost estimation for the making of a proposed product
- ◆ Listing of industries located in your area and methods of costing adopted by them
- ◆ Collection of financial statements of any two organization for two years and prepare a common Size Statements
- ◆ Collection of cost sheet and pro-forma of quotation
- ◆ Examinations (Scheduled and surprise tests)



A. G & S.G. SIDDHARTHA DEGREE COLLEGE OF ARTS & SCIENCE

Vuyyuru-521165.

NAAC reaccredited at 'A' level
Autonomous -ISO 9001 – 2015 Certified

TITLE OF THE PAPER: Cost and Management Accounting
Semester: IV

MODEL PAPER

TIME -3hrs

SECTION-A

Max. Marks: 70

Answer any Two of the following

2x5=10M

1. Define management Accounting
2. Write about Techniques of Inventory control
3. Features of Job Costing
4. Write about CVP analysis

Section-B

Answer any FOUR of the following

4x15=60

5. Define Cost Accounting Explain its Objectives?
6. Explain different methods of financial statement analysis?
7. From the following particulars you are required to prepare a cost sheet for the year ending 31.12.2009.

	Rs.
Stock of finished goods 31-12-2008	72,800.
Stock of raw materials on 31-12-2008	33,280.
Purchase of raw materials	7,59,200.
Wages	5,16,880.
Sales	15,39,200.
Stock of finished goods on 31-12-2009	78,000.
Stock of Raw materials on 31-12-2009	35,360
Works overhead charges	1,29,220
Office overheads	70,161

The company is intending to send a quotation for a large plant. The estimated material cost is Rs. 52,000 and wages Rs. 31,200. The quotation is to make a profit of 20% on selling price. Show the amount of quotation price.

8.. X Ltd has purchased and issued the material in the following order

Jan	1	Purchased	300 units @Rs.3/-per units
	4	purchased	600 <u>units@Rs.4/-per</u> units

6	Issue	500 units	
10	Purchased		700 units @ Rs.4/ per units
15	Issue	800 units	
20.	purchased		300 units @Rs.5/per units
23.	issue	100 units	

Ascertain the quantity of closing stock as on 31st January and state what will be its value (in each case) if issues are made under the following methods:

(a) First in first out

9. From the following information relating to a worker. Calculate which of the following methods of wage payment is beneficial to the worker:

- (a) Time rate
- (b) Piece rate
- (c) Halsey plan.
 - (I) Standard Time in a week 45 hrs
 - (ii) Standard weekly production 450 units.
 - (III) Actual time taken by the worker 40hrs.
 - (iv) Piece rate Rs.2 per units
 - (v) Hourly rate Rs.25.

10. The Costing records of Gopi Engineering Company for job 777 reveals Materials Rs 6,015

Wages:	Dept .X : 100 Hours @ Rs 4.50 per hour
	Dept .Y : 65 Hours @ Rs 3.00 per hour
	Dept .Z : 35 Hours @ Rs 7.50 per hour

Over head expenses for these three departments were estimated as follows.

Variable overheads :

Dept .X	:Rs 10,000 for 2,500 labour hours
Dept .Y	Rs 6,000 for 2,000 labour hours
Dept .Z	:Rs 4,000 for 500 labour hours

Fixed overheads: estimated at Rs 40,000 for 10,000 Normal Working Hours .you are required to calculate the cost of job No 777.

11. The following are the balance sheets of X LTD., For the years ending 31st December , 2003 and 2004

Liabilities	2003	2004	Assets	2003	2004
Equity share capital ,			Fixed Assets		
Preference share .	2,00,000	3,30,000	(Less Depreciation)	2,40,000	3,50,000
Capital	1,00,000	30,000	Stock	40,000	50,000
Reserves	20,000	20,000	Debtors	1,00,000	1,25,000
Profit and Loss A/C	15,000	20,000	Bills receivables	20,000	60,000
Bank over draft	50,000	50,000	Prepaid Expenses	10,000	12,000
Creditors	40,000	50,000	Cash in hand	40,000	53,000
Provision for taxation	20,000	25,000	Cash at bank	10,000	30,000
Proposed Dividend	15,000	25,000			
	4,60,000	6,80,000		4,60,000	6,80,000

Prepare Comparative balance Sheet

12. From the following information pertaining to the two years, calculate.

(a) P/V ratio

(b) Amount of sales to earn profit of Rs40,000

(c) profit on sales Rs.1,20,000.

Years	Sales	Profit
1996	1,40,000	15,000
1997	1,60,000	20,000



**A. G & S.G. SIDDHARTHA DEGREE COLLEGE
OF ARTS & SCIENCE**

Vuyyuru-521165.

NAAC reaccruited at 'A' level

Autonomous -ISO 9001 – 2015 Certified

TITLE OF THE PAPER:Cost and Management
semester: IV

Guidelines to the paper setter

Marks	UNIT-I	UNIT-II	UNIT-III	UNIT-IV	UNIT-V
	Introduction:	Material and Labour Cost	Job Costing and Batch Costing	Financial Statement Analysis and Interpretation	Marginal Costing
5Marks	1	1	1		1
15Marks	1T&1P	1P&1P	1P	1T&1P	1P
Weightage	35	35	20	30	20



A. G & S.G. SIDDHARTHA DEGREE COLLEGE OF ARTS & SCIENCE

Vuyyuru-521165.

NAAC reaccruited at 'A' level

Autonomous -ISO 9001 – 2015 Certified

TITLE OF THE PAPER: Income Tax

Semester: IV

Course Code	CIT-403G/C	Course Delivery Method	Class Room / Blended Mode - Both
Credits	4	CIA Marks	30
No. of Lecture Hours / Week	5	Semester End Exam Marks	70
Total Number of Lecture Hours	75	Total Marks	100
Year of Introduction:	Year of Offering: 2021 - 22	Year of Revision: ---	Percentage of Revision: 0%
CLASS:	II.B.COM., (gen/computer)		

Learning Outcomes:

At the end of the course, the student will able to;

- ❖ Acquire the complete knowledge of the tax evasion, tax avoidance and tax planning.
- ❖ Understand the provisions and compute income tax for various sources.
- ❖ Grasp amendments made from time to time in Finance Act.
- ❖ Compute total income and define tax complicacies and structure.
- ❖ Prepare and File IT returns of individual at his own.
- ❖ Prepare analysis of various special decisions, using relevant management techniques

Syllabus Income Tax

Course Details

Unit	Learning Units	Lecture Hours
I	Introduction: Income Tax Act-1961 - Basic Concepts: Income, Person, Assesses - Assessment Year, Previous Year, Rates of Tax, Agricultural Income, Residential Status of Individual - Incidence of Tax – Incomes Exempt from Tax (theory only).	15
II	Income from Salaries: Basis of Charge, Tax Treatment of Different Types of Salaries Allowances, Perquisites, Profits in Lieu of Salary, Deductions from Salary Income, Computation of Salary Income (including problems).	15
III	Income from House Property and Profits and Gains from Business: Annual Value, Let-out/Self Occupied/Deemed to be Let-out house -Deductions from Annual Value - Computation of Income from House Property Definition of Business and Profession – Procedure for Computation of Income from Business – Revenue and Capital Nature of Incomes and Expenses – Allowable Expenses – Expenses Expressly Disallowed – Computation (including problems).	15
IV	Income from Capital Gains- Income from Other Sources: Meaning of Capital Asset – Types – Procedure for Computation of Long-term and Short-term Capital Gains/Losses Meaning of Other Sources - General Incomes – Specific Incomes – Computation (including problems).	15
V	Computation of Total Income of an Individual: Deductions under Section 80 - Computation of Total Income (Simple problems).	15

Reference Books:

1. Dr. Vinod; K. Singhania; Direct Taxes – Law and Practice, Taxman Publications
2. T. S. Reddy and Dr. Y. Hari Prasad Reddy - Taxation , by Margham Publications
3. Premraj and Sreedhar, Income Tax, Hamsrala Publications
4. B.B. Lal - Direct Taxes; Konark Publications
5. Dr. Mehrotra and Dr. Goyal -Direct Taxes, Law and Practice, SahityaBhavan

Co-Curricular Activities:

- Seminar on different topics of Income tax
- Quiz programs
- Problem Solving Exercises
- Debate on Tax Evasion and Avoidance
- Practice of provisions of Taxation
- Visit a Tax firm
- Talk on Finance Bill at the time of Union Budget
- Guest lecture by Chartered Accountant
- Presentation of tax rates



**A. G & S.G. SIDDHARTHA DEGREE COLLEGE
OF ARTS & SCIENCE**

Vuyyuru-521165.

NAAC re accredited at 'A' level
Autonomous -ISO 9001 – 2015 Certified

TITLE OF THE PAPER: Income Tax
Semester: IV

Model Question Paper

Time: 3 Hrs

Max. Marks: 70

SECTION – A

I. Answer any TWO of the following

2X 5 = 10M

1. Explain about Agricultural income
2. Describe House rent allowance
3. Explain Gross annual value
4. Surcharge

SECTION – B

II. Answer any Four of the following

4 x15 =60M

5. How would you determine the Residential status of a Person.
6. Explain different Perquisites?
7. From the following particulars of sriram, a manger of a firm, compute his taxable Income from Salary
 - a) Basic pay Rs 6000 P.M
 - b) Dearness allowance Rs400 P.M
 - c) Own contribution to R.P.F Rs 3000 P.M
 - d)Employee's contribution to R.P.F Rs 3000 P.M
 - e) Interested credited to R.P.F 13% P.A Rs 4680
 - f) House rent allowance Rs7200P.M Rent paid in Delhi Rs5000 P.M
 - g) Medical allowance Rs100 P.M
 - h) Entertainment allowance Rs. 300 P.M

8. Explain how the Income from House Property is computed under the provision of the provision under the Provision of the Income Tax Act 1961

9. Compute income from House property Municipal valuation 16,000 P A. Fair rent 1,80,000 P.A ,Standard rent 1,50,000 P.A , Rent received 1,72,000 P A Municipal taxes 10% Municipal taxes are borne by the owner. Fire insurance Rs 3000, Interest on money borrowed for construction of house property paid Rs .36, 000 The House is let-out throughout the previous year.

10. What are the General Income and Specific Incomes under head "Income from Other Sources

11. Mr. Prasad submits the following particulars about sale of assets Calculate the amount of taxable capital gain.

<u>Particulars</u>	<u>JewelleryPlot Gold</u>		
Sale Price	12, 00,000	50, 80,000	10,20,000
Expenses on sale	10,000	36,000	Nil
Cost of Acquisition	90,000	4, 20,000	1,30,000
Year of Acquisition	1989-90	1986-87	2003-04
CII	172	140	109

CII for 2019-20 is: 289

12. Compute Total Income of Sri Saibaba, an Indian resident of 30 years age

Gross Salary=86,000
 Income from house property (computed)=20,000
 Short term capital loss=10,000
 Long term capital loss(Building)=12,000
 Income from profession=5,000
 Interest on securities(Gross)=4,000
 Income from Govt. Securities(Gross)=16,750



**A. G & S.G. SIDDHARTHA DEGREE COLLEGE
OF ARTS & SCIENCE**

Vuyyuru-521165.

NAAC reaccredited at 'A' level

Autonomous -ISO 9001 – 2015 Certified

**TITLE OF THE PAPER:Income Tax
Semester: IV**

Guidelines to the paper setter

Marks	UNIT-I	UNIT-II	UNIT-III	UNIT-IV	UNIT-V
	Introduction	Income from Salaries	Income from House Property and Profits and Gains from Business	Income from Capital Gains- Income from Other Sources	Computation of Total Income of an Individual:
5Marks	1	1	1	--	1
15Marks	1T	1T&1P	1T&1P	1T&1P	1P
Weightage	20	35	35	30	20



A. G & S.G. SIDDHARTHA DEGREE COLLEGE OF ARTS & SCIENCE

Vuyyuru-521165.

NAAC reaccredited at 'A' level
Autonomous -ISO 9001 – 2015 Certified

TITLE OF THE PAPER::Business Laws

Semester: IV

Course Code	CBL-404G/C	Course Delivery Method	Class Room / Blended Mode - Both
Credits	4	CIA Marks	30
No. of Lecture Hours / Week	5	Semester End Exam Marks	70
Total Number of Lecture Hours	75	Total Marks	100
Year of Introduction:	Year of Offering: 2021 - 22	Year of Revision: —	Percentage of Revision: 0%
CLASS:	II.B.COM., (gen/computer)		

Learning Outcomes:

At the end of the course, the student will able to;

- Understand the legal environment of business and laws of business.
- Highlight the security aspects in the present cyber-crime scenario.
- Apply basic legal knowledge to business transactions.
- Understand the various provisions of Company Law.
- Engage critical thinking to predict outcomes and recommend appropriate action on
- Issues relating to business associations and legal issues.
- Integrate concept of business law with foreign trade.

Syllabus Business Laws

Course Details

Unit	Learning Units	Lecture Hours
I	Contract: Meaning and Definition of Contract - Essential Elements of Valid Contract - Valid, Void and Voidable Contracts - Indian Contract Act, 1872	15
II	Offer, Acceptance and Consideration: Definition of Valid Offer, Acceptance and Consideration - Essential Elements of a Valid Offer, Acceptance and Consideration.	15
III	Capacity of the Parties and Contingent Contract: Rules Regarding to Minors Contracts - Rules Relating to Contingent Contracts - Different Modes of Discharge of Contracts - Rules Relating to Remedies to Breach of Contract.	15
IV	Sale of Goods Act 1930 and Consumer Protection Act 2019: Contract of Sale - Sale and Agreement to Sell - Implied Conditions and Warranties - Rights of Unpaid Vendor- Definition of Consumer - Person - Goods - Service - Consumer Dispute - Consumer Protection Councils - Consumer Dispute Redressed Mechanism	15
V	Cyber Law: Overview and Need for Cyber Law - Contract Procedures - Digital Signature – Safety Mechanisms	15

References:

1. J. Jaysankar, Business Laws, MarghamPublication.Chennai.
2. ND Kapoor, Business Laws, S Chand Publications.
3. Balachandram V, Business law, Tata McGraw Hill.
4. Tulsian, Business Law, Tata McGraw Hill.
5. PillaiBhagavathi, Business Law,SChand Publications

Co-Curricular Activities:

- ◆ Seminar on Basics of Indian Contract Act,1872
- ◆ Quiz programs
- ◆ Co-operative learning
- ◆ Seminar on Cyber Law
- ◆ Group Discussions
- ◆ Debate on Offer, Agreement, and Contract
- ◆ Creation of Contract by abiding rules of Indian Contract Act,1872
- ◆ Making a sale by abiding rules of Sale of Goods Act,1930
- ◆ Guest lecture by a Lawyer/Police officer
- ◆ Celebrating consumers day by creating awareness among the students
- ◆ Examinations (Scheduled and surprise tests)
- ◆ Any similar activities with imaginative thinking beyond the prescribed syllabus



**A. G & S.G. SIDDHARTHA DEGREE COLLEGE
OF ARTS & SCIENCE**

Vuyyuru-521165.

NAAC reaccruited at 'A' level

Autonomous -ISO 9001 – 2015 Certified

TITLE OF THE PAPER: Business Laws

Semester: IV

MODEL PAPER

TIME -3hrs

Max. Marks: 70

SECTION-A

I. Answer any TWO of the following

2x5=10M

1. What is a Valid Contract?
2. Acceptance
3. Contingent contracts
4. Unpaid seller

SECTION-B

II. Answer any FOUR of the following

4x15=60M

5. Define the term contract? What are the essentials of a valid contract?
6. Define consideration? What are legal rules to considerate?
7. Write about rules regarding Minors agreement?
8. What are the remedies available to an aggrieved party on the breach of Contract?
9. Define Offer? What are the essentials of a valid Offer?
10. Explain briefly the implied conditions and warranties in a contract of sale?
11. Explain the provisions regarding secure electronic records and secure digital signatures?
12. Define consumer? What are the rights of a consumer under consumer Protection act, 2019?



**A. G & S.G. SIDDHARTHA DEGREE COLLEGE
OF ARTS & SCIENCE**

Vuyyuru-521165.

NAAC re accredited at 'A' level

Autonomous -ISO 9001 – 2015 Certified

TITLE OF THE PAPER: Business Laws

Semester: IV

Guidelines to the paper setter

Marks	UNIT-I	UNIT-II	UNIT-III	UNIT-IV	UNIT-V
	Contract	Offer, Acceptance and Consideration	Capacity of the Parties and Contingent Contract:	Sale of Goods Act 1930 and Consumer Protection Act 2019	Cyber Laws
5Marks	1	1	1	1	-
15Marks	1	2	2	2	1
Weight age	20	35	35	35	15



A. G & S.G. SIDDHARTHA DEGREE COLLEGE OF ARTS & SCIENCE

Vuyyuru-521165.

NAAC reaccredited at 'A' level

Autonomous -ISO 9001 – 2015 Certified

TITLE OF THE PAPER: Auditing

Semester: IV

Course Code	CAUD-405G/C	Course Delivery Method	Class Room / Blended Mode - Both
Credits	4	CIA Marks	30
No. of Lecture Hours / Week	5	Semester End Exam Marks	70
Total Number of Lecture Hours	75	Total Marks	100
Year of Introduction:	Year of Offering: 2021 - 22	Year of Revision: —	Percentage of Revision: 0%
CLASS:	II.B.COM., (gen)		

Course Objectives:

1. To impart knowledge pertaining to basic concepts of auditing.
2. To make the students learn the basics of rights and duties regarding auditing and audit report.
3. To acquaint oneself with auditing procedure.

Learning Outcomes:

At the end of the course, the student will able to

- ❖ Understanding the meaning and necessity of audit in modern era
- ❖ Comprehend the role of auditor in avoiding the corporate frauds
- ❖ Identify the steps involved in performing audit process
- ❖ Determine the appropriate audit report for a given audit situation
- ❖ Apply auditing practices to different types of business entities
- ❖ Plan an audit by considering concepts of evidence, risk and materiality

Syllabus Auditing

Course Details

Unit	Learning Units	Lecture Hours
I	Introduction: Meaning – Objectives – Importance of Auditing – Characteristics - Book Keeping vs Auditing - Accounting vs Auditing – Role of Auditor in Checking Corporate Frauds.	15
II	Types of Audit: Based on Ownership, Time and Objective - Independent, Financial, Internal, Cost, Tax, Government, Secretarial Audits	15
III	Planning of Audit: Steps to be taken at the Commencement of a New Audit – Audit Programme - Audit Note Book– Audit Working Papers - Audit Evidence - Internal Check, Internal Audit and Internal Control.	15
IV	Vouching and Investigation: Definition and Importance of Vouching – Objectives of Vouching -Vouching of Cash and Trading Transactions – Investigation - Auditing vs. Investigation	15
V	Company Audit and Auditors Report: Auditor's Qualifications – Appointment and Reappointment – Rights, Duties, Liabilities and Disqualifications - Audit Report: Contents –Preparation - Relevant Provisions of Companies Act, 2013.	15

References:

1. S.Vengadamani, "Practical Auditing", Margham Publications, Chennai.
2. Ghatalia, "Principles of Auditing", Allied Publishers Pvt. Ltd., New Delhi.
3. Pradeesh Kumar, BaldevSachdeva&Jagwant Singh, "Auditing Theory and Practice,Kalyani Publications
4. N.D. Kapoor, "Auditing", S Chand, New Delhi.
5. R.G. Saxena, "Principles and Practice of Auditing", Himalaya Publishing House New Delhi.

Co-Curricular Activities:

- Seminars
- Visit the audit firms
- Visit an audit firm, write about the procedure followed by them in Auditing the books of accounts of a firm.
- Guest lecture by an auditor
- Collect the information about types of audit conducted in any one Organization
- Collection of audit reports
- Group Discussions
- Draft an audit program.



**A. G & S.G. SIDDHARTHA DEGREE COLLEGE
OF ARTS & SCIENCE**

Vuyyuru-521165.

NAAC recredited at 'A' level

Autonomous -ISO 9001 – 2015 Certified

**TITLE OF THE PAPER: Auditing
Semester: IV**

TIME -3hrs

Max. Marks: 70

SECTION -A

I. Answer any TWO of the following question

2 x 5= 10M

1. Explain the scope of audit
2. Government Audit
3. Characteristics of Investigation.
4. Audit Report

SECTION -B

II. Answer any FOUR of the following questions

4x15=60M

5. Define auditing .Explain its features and its advantages.
6. What are the various types of audits classified on the basis of organization Structure?
7. What is internal control .Explain its advantages and disadvantages
8. What is audit program? Explain its advantages and disadvantages
9. "Vouching is the essence of auditing". Explain
10. Explain the difference between Investigation and auditing
11. Explain the rights and duties of an auditor.
12. Explain different types of Audit Reports



**A. G & S.G. SIDDHARTHA DEGREE COLLEGE
OF ARTS & SCIENCE**

Vuyyuru-521165.

NAAC recredited at 'A' level

Autonomous -ISO 9001 – 2015 Certified

**TITLE OF THE PAPER: Auditing
semester: IV**

Guidelines to the paper setter

Marks	UNIT-I	UNIT-II	UNIT-III	UNIT-IV	UNIT-V
	Introduction:	Types of Audit:	Planning of Audit:	Vouching and Investigation:	Company Audit and Auditor's Report
5Marks	1	1	---	1	1
15Marks	1	1	2	2	2
Weightage	20	20	30	35	35



A. G & S.G. SIDDHARTHA DEGREE COLLEGE OF ARTS & SCIENCE

Vuyyuru-521165.

NAAC reaccredited at 'A' level

Autonomous -ISO 9001 – 2015 Certified

TITLE OF THE PAPER: Goods and Service Taxes

Semester: IV

Course Code	CGST-406 G	Course Delivery Method	Class Room / Blended Mode - Both
Credits	4	CIA Marks	30
No. of Lecture Hours / Week	5	Semester End Exam Marks	70
Total Number of Lecture Hours	75	Total Marks	100
Year of Introduction:	Year of Offering: 2021 - 22	Year of Revision: —	Percentage of Revision: 0%
CLASS:	II.B.COM., (gen)		

Learning Outcomes:

At the end of the course, the student will be able to:

- ❖ Understand the basic principles underlying the Indirect Taxation Statutes.
- ❖ Examine the method of tax credit. Input and Output Tax credit and Cross Utilisation of Input Tax Credit.
- ❖ Identify and analyze the procedural aspects under different applicable statutes related to GST.
- ❖ Compute the assessable value of transactions related to goods and services for levy and determination of duty liability.
- ❖ Develop various GST Returns and reports for business transactions in Tally.

Syllabus
Goods and Service Taxes

Course Details

Unit	Learning Units	Lecture Hours
I	Introduction: Overview of GST - Concepts –Taxes Subsumed under GST – Components of GST- GST Council- Advantages of GST-GST Registration.	15
II	GST Principles –Vijay KelkarSha Committee Recommendations - Comprehensive Structure of GST Model in India: Single, Dual GST – GST Rates - Taxes Exempted from GST- Taxes and Duties outside the purview of GST- Taxation of Services	15
III	Tax Invoice- Bill of Supply-Transactions Covered under GST-Composition Scheme- Reverse Charge Mechanism- Composite Supply -Mixed Supply	15
IV	Time of Supply of Goods & Services: Value of Supply - Input Tax Credit - Distribution of Credit -Matching of Input Tax Credit - Availability of Credit in Special Circumstances- Cross utilization of ITC between the Central GST and the State GST.	15
V	GST Returns: Regular Monthly Filing Returns-Composition Quarterly Filing Returns-GSTR-1, GSTR-2, GSTR 2A, GSTR-3, GSTR 3B -Annual Returns GSTR-9, GSTR 9A, GSTR 9B& GSTR 9C - Records to be Maintained under GST	15

References:

1. T. S. Reddy and Dr. Y. Hari Prasad Reddy, Business Taxation (Goods and Services Taxes), Margham Publications.
2. Taxmann's Basics of GST.
3. Taxmann's GST: A practical Approach.
4. Theory & Practice of GST, Srivathsala, Himalaya Publishing House.
5. Goods and Services Tax in India - Notifications on different dates. Library activities:

Co-Curricular Activities:

- Seminars
- Show the flow chart of GST Suvidha Provider (GST).
- Practice of Terminology of Goods and Service Tax
- Prepare chart showing rates of GST
- Follow GST Council meeting updates regularly
- Creation of GST Vouchers and Tax invoices
- Visit a Tax firm (Individual and Group)
- Guest lecture by GST official
- Prepare Tax invoice under the GST Act.
- Practice on how to file a Returns
- Debate on Single GS, Dual GST
- Group Discussions on Goods and Services outside the Purview of GST



**A. G & S.G. SIDDHARTHA DEGREE COLLEGE
OF ARTS & SCIENCE**

Vuyyuru-521165.

NAAC reaccruited at 'A' level

Autonomous -ISO 9001 – 2015 Certified

TITLE OF THE PAPER: Goods and Service Taxes

Semester: IV

TIME -3hrs

Model paper

Max. Marks: 70

SECTION-A

I. Answer any TWO of the following

2x5=10M

1. What is GST?
2. Dual GST
3. Reverse Charge Mechanism
4. Write about GSTR 9C

SECTION-B

II. Answer any FOUR of the following

4x15=60M

5. What are the advantages of Goods and Services Tax
6. What is the Comprehensive Structure of GST in India?
7. Write about Vijay KelkarSha Committee Recommendations
8. Explain the Billof Supply Transactions in GST
9. Write about GST Composition Scheme?
10. What is Input Tax Credit and explain it with suitable Examples
11. What are the Records to be maintained under GST?
12. Explain about Annual Returns GSTR-9, GSTR 9A, GSTR 9B& GSTR 9C in GST



**A. G & S.G. SIDDHARTHA DEGREE COLLEGE
OF ARTS & SCIENCE**

Vuyyuru-521165.

NAAC reaccruited at 'A' level

Autonomous -ISO 9001 – 2015 Certified

**TITLE OF THE PAPER: Goods and Service Taxes
semester: IV**

Guidelines to the paper setter

Marks	UNIT-I	UNIT-II	UNIT-III	UNIT-IV	UNIT-V
	Introduction	GST Principles	Tax Invoice	Time of Supply of Goods & Services:	GST Returns
5Marks	1	1	1	—	1
15Marks	1	2	2	1	2
Weight age	20	35	35	15	35



**A. G & S.G. SIDDHARTHA DEGREE COLLEGE
OF ARTS & SCIENCE**

Vuyyuru-521165.

NAAC reaccredited at 'A' level

Autonomous -ISO 9001 – 2015 Certified

TITLE OF THE PAPER: Event management

Semester: VI

Course Code	CEM-601 G/C C	Course Delivery Method	Class Room / Blended Mode - Both
Credits	2	CIA Marks	---
No. of Lecture Hours / Week	2	Semester End Exam Marks	50
Total Number of Lecture Hours	30	Total Marks	50
Year of Introduction:	Year of Offering: 2017-18	Year of Revision: ---	Percentage of Revision: 0%
CLASS:	III.B.Com(gen/comp)		

COURSE OBJECTIVES:

1. Identifying events and determining corresponding control measures that events can be programmed in such a way that operational information is transferred
2. Develop and implement financial initiatives based on event objectives through methods such as sponsorship programs, grant applications, and fundraising initiatives. Plan, design, and coordinate effective site and facility operations.

COURSE OUTCOMES:

CO1. Identify the needs of customers for organizing a corporate event and understand the types of Events.

CO2: Examine various types of Outdoor events and Managing the risk in the events. Relate Marketing management, Human Resource Management to Event Management

CO3: Students able to organize Shows, fashion shows, high profile charity events.

SYLLABUS

Event Management

Course Details:

Unit	Learning Units	Lecture Hours
I	Event Concept: Corporate Events and Customer's needs - Types of Events - Corporate hospitality – Exhibitions – Trade Fairs – Conferences –Business and Government Meets - Corporate event packages - Menu Selection - Customization.	10
II	. Outdoor Events: Logistics, Types of Outdoor events, Risk management - Health and safety, Marketing and sponsorship, HR Management, Programming and Entertainment.	10
III	Celebrity Events: Launches, Fashion shows, National festivals and high-profile charity events - Liaison with agents, Contract Negotiations, Client briefings, Celebrity wish lists and expectations - Liaisoning with Govt. Departments.	10

References:

1. Event Management: A Blooming Industry and an Eventful Career by Devesh Kishore, Ganga Sagar Singh - Har-and Publications Pvt. Ltd.
2. Event Management by Swarup K. Goyal - Adhyayan Publisher.
3. Event Management & Public Relations by Savita Mohan - Enkay Publishing House
4. Event Entertainment and Production - Mark Sonder, CSEP, Wiley & Sons, Inc.
5. Special Event Production - Doug Matthews. 6. Fenich, G. Meetings, Expositions, Events, and Conventions: An introduction to the industry. New Jersey: Pearson Prentice Hall.



**A. G & S.G. SIDDHARTHA DEGREE COLLEGE
OF ARTS & SCIENCE**

Vuyyuru-521165.

NAAC reaccruited at 'A' level

Autonomous -ISO 9001 – 2015 Certified

TITLE OF THE PAPER: Event management

Semester: VI

Model paper

Event Management

Time: 3 hrs

Max. Marks: 50

SECTION- A

I. Answer any FOUR of the following questions

4 x 5= 20M

1. Corporate Hospitality
2. Trade Fairs
3. Risk Management
4. Sponsorship
5. Fashion Shows
6. Liaising

SECTION- B

II. Answer any THREE of the following questions

3 x 10 = 30M

7. Explain Different Types of Events
8. What are the uses of Exhibitions
9. Explain Different Types of Logistics
10. What is Programming of an Event and Entertainment
11. Who would launch a Product
12. Explain about High profile Charity Events.



**A. G & S.G. SIDDHARTHA DEGREE COLLEGE
OF ARTS & SCIENCE**

Vuyyuru-521165.

NAAC re accredited at 'A' level
Autonomous -ISO 9001 – 2015 Certified

TITLE OF THE PAPER: Event management
Semester:VI

Guidelines to the paper setter

	UNIT-I	UNIT-II	UNIT-III
	Event Concept	Out Door Events	Celebrity Events
5 Marks questions	2	2	2
10 Marks questions	2	2	2
Weight age	30	30	30



A. G & S.G. SIDDHARTHA DEGREE COLLEGE OF ARTS & SCIENCE

Vuyyuru-521165.

NAAC reaccruited at 'A' level

Autonomous -ISO 9001 – 2015 Certified

TITLE OF THE PAPER:Marketing

Semester: VI

Course Code	CM-602GE G/C C	Course Delivery Method	Class Room / Blended Mode - Both
Credits	4	CIA Marks	30
No. of Lecture Hours / Week	5	Semester End Exam Marks	70
Total Number of Lecture Hours	75	Total Marks	100
Year of Introduction:	Year of Offering: 2017-18	Year of Revision: —	Percentage of Revision: 0%
CLASS:	III.B.Com(gen/comp)		

CourseObjective:

- 1.To acquire knowledge on marketing concepts, 7P's, to build applicable skills through variety internship opportunities
2. Student will gain understanding of consumer buyer behaviour, pricing strategies and ethical concept of marketing

Course Outcomes:

C01: To introduce the concepts of marketing and understand the factors influence the market environment.

C02: Analyze the consumer market models and enlightens consumer buyer behaviour models.

C03: Understand the concept of product and identify the need of product mix and product line decisions.

C04: Develop an idea about pricing strategies and pricing decisions.

C05: Enhance the students about decisions regarding promotion and distribution channels.

Syllabus

Marketing

Course Details

Unit	Learning Units	Lecture Hours
I	Introduction: Concepts of Marketing: Product Concept – Selling Concept - Societal Marketing Concept – Marketing Mix - 4 P's of Marketing – Marketing Environment.	15
II	Consumer Markets and Buyer Behavior: Buying Decision Process – Stages – Buying Behavior – Market Segmentation – Selecting Segments – Advantages of Segmentation.	15
III	Product Management: Product Life Cycle - New products, Product mix and Product line decisions - Design, Branding, Packaging and Labeling.	15
IV	: Pricing Decision: Factors influencing price determination, Pricing strategies: Skimming and Penetration pricing.	15
V	Promotion and Distribution: Promotion Mix - Advertising - Publicity – Public relations - Personal selling and Direct marketing - Distribution Channels – Online marketing- Global marketing.	15

References:

1. Philip Kotler, Marketing Management, Prentice Hall of India.
2. Philip Kotler & Gary Armstrong, Principles of Marketing, Pearson Prentice Hall
3. Stanton J. William & Charles Futrel, Fundamentals of Marketing, McGraw Hill Company
4. V.S. Ramaswamy S. NamaKumari, Marketing Management – Planning, McMillan



**A. G & S.G. SIDDHARTHA DEGREE COLLEGE
OF ARTS & SCIENCE**

Vuyyuru-521165.

NAAC reaccruited at 'A' level
Autonomous -ISO 9001 – 2015 Certified

**TITLE OF THE PAPER:Marketing
Semester: VI**

Model paper

Marketing

Time: 3 hrs

Max. Marks: 70

SECTION- A

I. Answer any TWO of the following questions

2x 5= 10M

1. Selling Concept
2. What is Consumer Behavior?
3. What is New Product?
4. Global marketing

SECTION- B

II. Answer any FOUR of the following questions

4 x 15 = 60M

5. Describe 4P's of Marketing
6. What are the Different Concepts of Marketing?
7. What is Market Segmentation?
8. Describe Product Life Cycle.
9. What is the Factor Influencing Price Determination?
10. What are the differences Between Personal selling and direct Marketing?
11. Advantages and disadvantages Packaging and labelling
12. What Steps are Involved in Consumer behaviour



**A. G & S.G. SIDDHARTHA DEGREE COLLEGE
OF ARTS & SCIENCE**

Vuyyuru-521165.

NAAC re accredited at 'A' level

Autonomous -ISO 9001 – 2015 Certified

TITLE OF THE PAPER:Marketing

Semester: VI

Guidelines to the paper setter

Marks	UNIT-I	UNIT-II	UNIT-III	UNIT-IV	UNIT-V
	Introduction	Consumer Markets and buyer Behavior	Product Management	Pricing decision	Promotion and Distribution
5Marks	1	1	1	–	1
15Marks	2	2	2	1	1
Weightage	35	35	35	15	20



A. G & S.G. SIDDHARTHA DEGREE COLLEGE OF ARTS & SCIENCE

Vuyyuru-521165.

NAAC reaccruited at 'A' level
Autonomous -ISO 9001 – 2015 Certified

TITLE OF THE PAPER: Auditing
Semester: VI

Course Code	CAU-603GE G/C C	Course Delivery Method	Class Room / Blended Mode - Both
Credits	4	CIA Marks	30
No. of Lecture Hours / Week	5	Semester End Exam Marks	70
Total Number of Lecture Hours	75	Total Marks	100
Year of Introduction:	Year of Offering: 2017-18	Year of Revision: ---	Percentage of Revision: 0%
CLASS:	III.B.COM., (gen/computer)		

Course Objectives:

4. To impart knowledge pertaining to basic concepts of auditing.
5. To make the students learn the basics of rights and duties regarding auditing and audit report.
6. To acquaint oneself with auditing procedure.

Learning Outcomes:

At the end of the course, the student will able to

- ❖ Understanding the meaning and necessity of audit in modern era
- ❖ Comprehend the role of auditor in avoiding the corporate frauds
- ❖ Identify the steps involved in performing audit process
- ❖ Determine the appropriate audit report for a given audit situation
- ❖ Apply auditing practices to different types of business entities
- ❖ Plan an audit by considering concepts of evidence, risk and materiality

Syllabus Auditing

Course Details

Unit	Learning Units	Lecture Hours
I	Introduction: Meaning – Objectives – Importance of Auditing – Characteristics - Book Keeping vs Auditing - Accounting vs Auditing – Role of Auditor in Checking Corporate Frauds.	15
II	Types of Audit: Based on Ownership, Time and Objective - Independent, Financial, Internal, Cost, Tax, Government, Secretarial Audits	15
III	Planning of Audit: Steps to be taken at the Commencement of a New Audit – Audit Program - Audit Note Book– Audit Working Papers - Audit Evidence - Internal Check, Internal Audit and Internal Control.	15
IV	Vouching and Investigation: Definition and Importance of Vouching – Objectives of Vouching -Vouching of Cash and Trading Transactions – Investigation - Auditing vs. Investigation	15
V	Company Audit and Auditors Report: Auditor's Qualifications – Appointment and Reappointment – Rights, Duties, Liabilities and Disqualifications - Audit Report: Contents –Preparation - Relevant Provisions of Companies Act, 2013.	15

References:

1. S.Vengadamani, "Practical Auditing", Margham Publications, Chennai.
2. Ghatalia, "Principles of Auditing", Allied Publishers Pvt. Ltd., New Delhi.
3. Pradeesh Kumar, BaldevSachdeva&Jagwant Singh, "Auditing Theory and Practice,Kalyani Publications
4. N.D. Kapoor, "Auditing", S Chand, New Delhi.
5. R.G. Saxena, "Principles and Practice of Auditing", Himalaya Publishing House

New Delhi

Co-Curricular Activities:

- Seminars
- Visit the audit firms
- Visit an audit firm, write about the procedure followed by them in Auditing the books of accounts of a firm.
- Guest lecture by an auditor
- Collect the information about types of audit conducted in any one Organization
- Collection of audit reports
- Group Discussions
- Draft an audit program.



**A. G & S.G. SIDDHARTHA DEGREE COLLEGE
OF ARTS & SCIENCE**

Vuyyuru-521165.

NAAC reaccredited at 'A' level
Autonomous -ISO 9001 – 2015 Certified

TITLE OF THE PAPER: Auditing
Semester: VI

TIME -3hrs

Max. Marks: 70

SECTION -A

I. Answer any TWO of the following question

2 x 5= 10M

1. Explain the scope of audit
2. Government Audit
3. Characteristics of Investigation.
4. Audit Report

SECTION -B

II. Answer any FOUR of the following questions

4x15=60M 5.

Define auditing .Explain its features and its advantages.

6. What are the various types of audits classified on the basis of organization Structure?
7. What is audit program me. Explain its advantages and disadvantages
8. What is internal control .Explain its advantages and disadvantages
9. "Vouching is the essence of auditing". Explain
10. Explain the difference between Investigation and auditing
11. Explain the rights and duties of an auditor.
12. Explain different types of Audit Reports



**A. G & S.G. SIDDHARTHA DEGREE COLLEGE
OF ARTS & SCIENCE**

Vuyyuru-521165.

NAAC reaccruited at 'A' level

Autonomous -ISO 9001 – 2015 Certified

TITLE OF THE PAPER: Auditing

Semester: VI

Guidelines to the paper setter

Marks	UNIT-I Auditing	UNIT-II Types of Audit	UNIT-III Planning of Audit	UNIT-IV Vouching and Investigation	UNIT-V Company audit and Auditors Reports
5Marks	1	1	---	1	1
15Marks	1	1	2	2	2
Weight age	20	20	30	35	35



A. G & S.G. SIDDHARTHA DEGREE COLLEGE OF ARTS & SCIENCE

Vuyyuru-521165.

NAAC reaccredited at 'A' level
Autonomous -ISO 9001 – 2015 Certified

TITLE OF THE PAPER: Management Accounting
Semester: VI

Course Code	CMA-604GE G/C C	Course Delivery Method	Class Room / Blended Mode - Both
Credits	4	CIA Marks	30
No. of Lecture Hours / Week	5	Semester End Exam Marks	70
Total Number of Lecture Hours	75	Total Marks	100
Year of Introduction:	Year of Offering: 2017-18	Year of Revision: —	Percentage of Revision: 0%
CLASS:	III.B.COM., (gen/computer)		

Course Objective:

- 1.To acquire knowledge about management accounting its applications, ratios and CVP analysis.
- 2.To acquire knowledge about preparation of various financial statements

Course Outcome:

CO1 – Students will critically understanding the financial and management accounting importance in understanding the business operations using different tools

CO2 – Students will understand the importance of changes of working capital for any Organisation and analysing the flow of fund

CO3 – Students will critically understanding the cash and fund flow concept and impact of cash flow on business operations

CO4 - Students will have the ability of assessing the solvency and profitability of any Organisation

CO5- Students will understand the profit making decisions in complex situations of any business Organisation

SYLLABUS
Management Accounting

Course Details

Unit	Learning Units	Lecture Hours
I	Management Accounting: Interface with Financial Accounting and Cost Accounting - Financial Statement analysis and interpretation: Comparative analysis – Common size analysis and trend analysis (including problems).	15
II	Ratio Analysis: Classification, Importance and limitations - Analysis and interpretation of Accounting ratios - Liquidity, profitability, activity and solvency ratios (including problems).	15
III	Fund Flow Statement: Concept of fund: Preparation of funds flow statement. Uses and limitations of funds flow analysis (including problems).	15
IV	Cash Flow Statement: Concept of cash flow – Preparation of cash flow statement – Uses and limitations of cash flow analysis (including problems).	15
V	Break-Even Analysis and Decision Making: Calculation of Break-even point - Uses and limitations - Margin of safety – Make/Buy Decision - Lease/own Decision (including Problems).	15

References:

1. S.N. Maheswari, A Textbook of Accounting for Management, S. Chand Publishing, New Delhi.
2. I.M Pandey, "Management Accounting", Vikas Publishing House, New Delhi,
3. Shashi K. Gupta & R.K. Sharma, "Management Accounting: Principles and Practice", KalyaniPublishers, Ludhiana.
4. JawaharLal, Accounting for Management, Himalaya Publishing House, New Delhi.
5. Charles T. Horngren, *et al*, "Introduction to Management Accounting" Person EducationIndia, New Delhi, 2002.



**A. G & S.G. SIDDHARTHA DEGREE COLLEGE
OF ARTS & SCIENCE**

Vuyyuru-521165.

NAAC reaccredited at 'A' level
Autonomous -ISO 9001 – 2015 Certified

TITLE OF THE PAPER: Management Accounting
Semester: VI

Time: 3 hrs

Max.Marks:70

SECTION – A

I. Answer any TWO from the following:

2x5=10M

1. Explain common – size statements
2. What are the uses of management accounting?
3. Describe the importance ratios
4. Define a fund flow statement.

SECTION – B

II. Answer any FOUR from the following:

4x15=60M

5). Following are the two balance sheets of 'A' LTD and 'B' LTD on 31-3-2008.

<i>Particulars</i>	<i>'A' ltd (Rs.)</i>	<i>'B' ltd. (Rs.)</i>
Assets:		
Cash	27	72
Sundry debtors	220	226
Stock	100	174
Prepaid expenses	11	21
Other current assets	10	21
Fixed assets (net)	635	513
Total assets	1003	1027
Liabilities & capital:		
Sundry creditors	42	154
Other current liabilities	78	62
Fixed liabilities	225	318
Capital	658	493
Total liabilities	1003	1027

From the above data, prepare a common-size statement and make comments

6).The following is the Balance sheet of Blhubaneswar Ltd., as on 30th June ,2008:

Liabilities	Rs.	Assets	Rs.
Equity share capital	3,00,000	Fixed assets	6,00,000
9% Pre f, share capital	1,00,000	Investments	50,000
10% Debentures	2,00,000	Current assets	2,50,000
Reserves and surplus	50,000		
Long- term Loans	25,000		
Current liabilities	2,25,000		
	9,00,000		9,00,000

You are required to calculate:

- Debt- equity ratio (long-term debt equity).
- Proprietary Ratio
- Solvency Ratio.
- Fixed assets to proprietor's funds ratio.
- Fixed assets ratio.
- Current assets to proprietor's funds ratio.

7). Following are the details of a company for the years 2006 and 2007, you are required to prepare Statement showing flow of funds :

Particulars	2006 Rs.	2007 Rs.
Assets:		
Cash	30,000	47,000
Debtors	1,20,000	1,15,000
Stock – in- trade	80,000	90,000
Land	50,000	66,000
	2,80,000	3,18,000
Capital and liabilities:		
Share capital	2,00,000	2,50,000
Trade creditors	70,000	45,000
Retained earnings	10,000	23,000
	2,80,000	3,18,000

		Rs.
Depreciation on Building	52,000	
Depreciation on plant and machinery	35,000	
Transfer to general reserve		10,000
Good will written off		
	8,000	
Plant and machinery having book value of Rs.14,000 was sold for		10,000
Profit on sale of investments		7,000

8). Define a cash flow statement. Distinguish between 'funds flow' and 'cash flow'.

9). X LTD, made a profit of Rs.18,00,000 for the year ended 31st march, 2008 after considering the following:

The following was the position of Current Assets and Current Liabilities of the company as on 31st march , 2007 and 31 march , 2008.

	31 st march 2007 Rs.	31 st march 2008 Rs.
Debtors	45,000	35,000
Stock	72,000	80,000
cash	12,000	21,000
creditors	56,000	62,000
outstanding expenses	7,000	5,000
Prepaid expenses	4,000	5,000
Bills payable	11,000	15,000

Calculate cash flows from operating activities.

10). From the following information pertaining to the two years, calculate.

- P/V ratio
- Amount of sales to earn profit of Rs 40, 000
- Profit on sales Rs.1, 20,000.

Years	Sales	Profit
1996	1, 40,000	15,000
1997	1, 60,000	20,000

11). Following are the balance Sheets of sun star Industries Ltd . for the years ending December 31, 2006 and 2007

Liabilities	2006 RS	2007 RS	Assets	2006 RS	2007 RS
Equity share capital	4,00,000	6,00,000	Land & Buildings	2,70,000	1,70,000
Reserves & surplus	3,12,000	3,54,000	Plant & Machinery	3,10,000	7,86,000
Debentures	50,000	1,00,000	Furniture & Fixture	9,000	18,000
Long – term loans on Mortgage	1,50,000	2,55,000	Other Fixed assets	20,000	30,000
Accounts Payable	2,55,000	1,17,000	Long – term Loans	46,000	59,000
Other Current Liabilities	7,000	10,000	Cash in hand and at Bank	1,18,000	10,000
			Receivables	2,09,000	1,90,000
			Inventory	1,60,000	1,30,000
			Prepared Expenses	3,000	3,000
			Other current assets	29,000	40,000
	11,74,000	14,36,000		11,74,000	14,36,000

Analyze the Financial position of the company with the help of Comparative Balance sheet

12). From the given information calculate

- (a) B.E.P
 - (b) Sales to earn a profit of Rs.1, 00,000
 - (c) Margin of safety where. Sales are Rs10, 00,000
- Total sales 6, 00,000
- Total variable costs 4, 00,000
- Total fixed costs 50,000



**A. G & S.G. SIDDHARTHA DEGREE COLLEGE
OF ARTS & SCIENCE**

Vuyyuru-521165.

NAAC reaccruited at 'A' level
Autonomous -ISO 9001 – 2015 Certified

TITLE OF THE PAPER:Management Accounting
Semester: VI

Guidelines to the paper setter

Marks	UNIT-I	UNIT-II	UNIT-III	UNIT-IV	UNIT-V
	Management Accounting	Ratio Analysis	Fund Flow Statement	Cash Flow Statement	Break-Even Analysis and Decision Making
5Marks	2	1	1	–	–
15Marks	2	1	1	1T+1P	2
Weightage	40	20	20	30	30



A. G & S.G. SIDDHARTHA DEGREE COLLEGE OF ARTS & SCIENCE

Vuyyuru-521165.

NAAC reaccruited at 'A' level
Autonomous -ISO 9001 – 2015 Certified

TITLE OF THE PAPER: Financial Services

Semester: VI

Course Code	CFS-605CE G/C	Course Delivery Method	Class Room / Blended Mode - Both
Credits	4	CIA Marks	30
No. of Lecture Hours / Week	5	Semester End Exam Marks	70
Total Number of Lecture Hours	75	Total Marks	100
Year of Introduction:	Year of Offering: 2017-18	Year of Revision: ---	Percentage of Revision: 0%
CLASS:	III.B.COM., (gen/computer)		

Course Objective:

- 1.To acquire knowledge about various financial services offered by banking and non-banking companies
2. Students will develop an idea of recent trends in financial services

Course Outcome:

CO1 – Students can impart knowledge about various financial services offered by banking and non-banking companies

CO2 – Students can understand various merchant banking services

CO3 – To know emergence and development of financial services in leasing and hire-purchase

CO4 – Students will acquire the knowledge of various credit rating agencies and concept of mutual funds

CO5- To understand the various financial services and their future

SYLLABUS
Financial Services

Course Details

Unit	Learning Units	Lecture Hours
I	Financial Services: Role of Financial Services - Banking and Non Banking Companies – Activities of Non Banking Finance Companies- Fund Based Activities - Fee Based Activities .	15
II	Merchant Banking Services: Scope and importance of merchant banking services - Venture Capital - Securitization –Demat services - Commercial Papers – Treasury bills	15
III	Leasing and Hire-Purchase: Types of Lease, Documentation and Legal aspects – Fixation of Rentals and Evaluation - Hire Purchasing- Securitization of debts - House Finance.	15
IV	Credit Rating: Purpose – Types – Credit Rating Symbols – Agencies: CRISIL and CARE – Equity Assessment vs. Grading – Mutual funds.	15
V	Break-Even Analysis and Decision Making: Calculation of Break-even point - Uses and limitations - Margin of safety – Make/Buy Decision - Lease/own Decision (including Problems).	15

References:

1. B. Santhanam, Financial Services, Margham Publication, Chennai.
2. M.Y. Khan, Financial Services, Tata McGraw – Hill, New Delhi.
3. Machendra Raja, Financial Services, S.Chand Publishers, New Delhi.
4. V. A. Avdhani, Marketing of Financial Services.
5. Machiraji, “Indian Financial System”, Vikas Publishers.
6. SandeepGoel, Financial Services, PHI Learning.
7. L.M. Bhole, Financial Institutions and Markets, Tata McGraw Hill.



**A. G & S.G. SIDDHARTHA DEGREE COLLEGE
OF ARTS & SCIENCE**

Vuyyuru-521165.

NAAC reaccruited at 'A' level
Autonomous -ISO 9001 – 2015 Certified

TITLE OF THE PAPER: Financial Services
Semester: VI

Model Paper

TIME -3hrs

Max. Marks: 70

SECTION -A

I. Answer any TWO of the following question

2 x 5= 10M

1. What are Banking Companies?
2. What is Venture Capital?
3. Hire Purchasing.
4. NSDL.

SECTION -B

II. Answer any Four of the following questions

4x15=60M

5. Explain the role of Financial Services
6. Explain the activities of Non Banking Finance Companies
7. Explain the Scope and Importance of Merchant Banking
8. Explain Demat services and Securitization
9. Explain the Types of Leases
10. Explain Different Credit rating agencies
11. Describe about Mutual funds
12. What are Central Depository Systems?



**A. G & S.G. SIDDHARTHA DEGREE COLLEGE
OF ARTS & SCIENCE**

Vuyyuru-521165.

NAAC reaccruited at 'A' level

Autonomous -ISO 9001 – 2015 Certified

TITLE OF THE PAPER: Financial Services

Semester: VI

Guidelines to the paper setter

Marks	UNIT-I	UNIT-II	UNIT-III	UNIT-IV	UNIT-V
	Financial Services	Merchant Banking Services	Leasing and Hire-Purchase	Credit Rating	Other Financial Services
5Marks	1	1	1	0	1
15Marks	2	2	1	2	1
Weightage	35	35	20	30	20



A. G & S.G. SIDDHARTHA DEGREE COLLEGE OF ARTS & SCIENCE

Vuyyuru-521165.

NAAC reaccredited at 'A' level
Autonomous -ISO 9001 – 2015 Certified

TITLE OF THE PAPER: MARKETING OF FINANCIAL SERVICES

Semester: VI

Course Code	CMFS-606CE G/C	Course Delivery Method	Class Room / Blended Mode - Both
Credits	4	CIA Marks	30
No. of Lecture Hours / Week	5	Semester End Exam Marks	70
Total Number of Lecture Hours	75	Total Marks	100
Year of Introduction:	Year of Offering: 2017-18	Year of Revision: —	Percentage of Revision: 0%
CLASS:	III.B.COM., (gen)		

Course Objectives:

- 1.To acquire knowledge about various financial services offered by banking and non banking companies
- 2.Students are able to learn basic concepts in marketing of financial servicesAnd environment

COURSE OUTCOMES:

- CO1 – Students are able to learn basic concepts in marketing of financial services
- CO2 –Students are able to learn the concepts of service environment
- CO3 –Students are able to impart knowledge about pricing strategies and promotion strategies
- CO4 – Students can impart knowledge regarding promotion and distribution
- CO5 –Students can impart knowledge about various retail financial services

SYLLABUS

Marketing of Financial Services

Course Details

Unit	Learning Units	Lecture Hours
I	Difference between Goods and Services: Managing Service Counters – Integrated Service Management – Service Elements.	15
II	:Constructing Service Environment – Managing People for service Advantage – Service Quality and Productivity – Customer Loyalty.	15
III	Pricing and Promotion Strategies: Pricing strategies – Promotion strategies – B2B Marketing – Marketing Planning and Control for services.	15
IV	Distributing Services: Cost and Revenue Management – Approaches for providing services - Channels for Service provision – Designing and managing Service Processes.	15
V	: Retail Financial Services - Investment services – Insurance services - Credit Services - Institutional Financial Services - Marketing practices in select Financial Service Firms.	15

References:

1. Aradhani “Marketing of Financial Services” Himalaya Publications
2. Sinha and Saho, Services Marketing, Himalaya Publishing House
3. Reddy Appanaiah, Anil Kumar and Nirmala, Services Marketing, Himalaya Publishing.
4. Shajahan, Services Marketing, Himalaya Publishing House.



**A. G & S.G. SIDDHARTHA DEGREE COLLEGE
OF ARTS & SCIENCE**

Vuyyuru-521165.

NAAC reaccruited at 'A' level
Autonomous -ISO 9001 – 2015 Certified

**TITLE OF THE PAPER: MARKETING OF FINANCIAL SERVICES
Semester: VI**

Model paper

TIME -3hrs

Max. Marks: 70

SECTION -A

I. Answer any TWO of the following question

2 x 5= 10M

1. What are the service elements?
2. Customer loyalty
3. Marketing Planning
4. Designing and Managing service process

SECTION -B

II. Answer any Four of the following questions

4x15=60M

5. Describe Managing Service Counters
6. Explain Service Quality and Productivity
7. Explain different Pricing strategies
8. Explain B2B Marketing
9. What are the different approaches for providing services?
10. What are the advantages of Cost and Revenue Management?
11. Explain Institutional Financial Services
12. Explain different Service Elements



**A. G & S.G. SIDDHARTHA DEGREE COLLEGE
OF ARTS & SCIENCE**

Vuyyuru-521165.

NAAC reaccruited at 'A' level

Autonomous -ISO 9001 – 2015 Certified

TITLE OF THE PAPER: MARKETING OF FINANCIAL SERVICES

Semester: VI

Guidelines to the paper setter

Marks	UNIT-I	UNIT-II	UNIT-III	UNIT-IV	UNIT-V
	Difference between Goods and Services	Constructing Service Environment	Pricing and Promotion Strategies	Distributing Services	Retail Financial Services
5Marks	1	1	1	1	---
15Marks	2	1	2	2	1
Weightage	35	20	35	35	15

**A.G& S.G.SIDDHARTHA DEGREE COLLEGE OF ARTS &
SCIENCE**

VUYYURU-521165, KRISHNA Dt., A.P.(Autonomous)

Accredited by NAAC with "A" Grade

2021-2022



DEPARTMENT OF STATISTICS

MINUTES OF BOARD OF STUDIES

ODD SEMESTER

12-11-2021

Minutes of the meeting of BOS in Statistics for B.Sc(MSCs) Degree Courses of AG&SGSiddhartha Degree College of Arts & Science, Vuyyuru, held at 3.00 PM on 12- 11-2021.

N.V. SrinivasaRao

Presiding

Members Present:

- | | | |
|---|--------------------|--|
| 1) <u><i>N.V. Rao</i></u>
(N.V.SrinivasaRao) | Chairman | Head, Department of Mathematics,
AG & SG S Degree College. |
| 2) <u><i>P. Ravi Kumar</i></u>
(P. Ravi Kumar) | University Nominee | Department of Statistics,
Pavitra Degree College,
Machilipatnam. |
| 3) <u><i>G. Chakravarthy</i></u>
(G. Chakravarthy) | Subject Expert | Head. Department of Statistics,
P. B. Siddhartha College,
Vijayawada |
| 4) <u><i>D. Sunitha</i></u>
(D.Sunitha) | Member | Lecturer in Mathematics
AG & SG S Degree College. |
| 5) <u><i>A. Bhargavi</i></u>
(A.Bhargavi) | Member | Lecturer in Mathematics
AG & SG S Degree College. |
| 6) <u><i>Noor Mohammad</i></u>
(Noor Mohammad) | Member | Lecturer in Mathematics
AG & SG S Degree College. |
| 7) <u><i>K. Rajya Lakshmi</i></u>
(K. Rajya Lakshmi) | Member | Lecturer in Mathematics
AG & SG S Degree College. |

Agenda of B.O.S Meeting:

1. To discuss and recommend the Syllabi, Model Question Papers and Guidelines to be followed by question paper setters in Statistics for 1stSemester as per the guidelines and instructions under APSCHE prescribed by Krishna University from the Academic Year 2021-22.
2. Discussed and recommended the teaching and evaluation methods for approval of Academic Council
3. Any other matter.

Resolutions.

1. To introduce new Syllabi, Model Question Papers and Guidelines to be followed by the question paper setters in Statistics of 1stSemester from the Academic year 2021-22.
2. To recommend the teaching and evaluation methods to be followed under Autonomous status. The maximum marks for IA is 25 and SE is 75. Each IA written examination is of 1 Hr. duration for 15 marks. The tests will be conducted centrally. The average of two such IA is calculated for 15 marks. 5 marks will be allotted basing on Assignment and 5 marks are allotted for activity. There is no minimum passing for IA and there is no provision for improvement in IA. Even though the candidate is absent for two IA exams/obtain zero marks the external marks are considered (if he/ she gets 40 out of 75) and the result shall be declared as 'PASS' from the Academic year 2021-22.
3. Discussed and recommended for organizing seminars, Guest lecturers, Online Examinations and Workshops to upgrade the knowledge of students for Competitive Examinations for the approval of the Academic Council.

A.G. & S.G. Siddhartha Degree College of Arts & Science
Vuyyuru, Krishna District
Department of Statistics
Programme Specific Outcomes (PSOs)

- PSO1 : Apply the concepts, principles and methods of statistics to various fields of study
- PSO2 : Understand the importance and value of statistical principles and convert a problem description into testable research hypotheses
- PSO3 : Select appropriate statistical tools to investigate a research hypothesis.
- PSO4 : Perform data analysis by apply appropriate statistical methodology and interpret result in a variety of settings
- PSO5 : Compute statistical measures using software and programs.

A. G & S. G Siddhartha Degree College of Arts and Science (Autonomous), Vuyyuru
 (An Autonomous College in the jurisdiction of Krishna University, Machilipatnam)

STATISTICS	STATIIB	2021-22 Onwards	B.Sc.(MSCs)
-------------------	----------------	------------------------	--------------------

SEMESTER-1 **PAPER - I** **No of Credits:4**
DESCRIPTIVE STATISTICS AND THEORY OF PROBABILITY

S. No	PROGRAMME OUTCOMES
PO1	Remember the basic concepts of statistics at different levels and to understand them for gaining of knowledge.
PO2	Apply the statistical techniques in the analysis of data and also acquire knowledge in optimization techniques.
PO3	Facilitate students to acquire flair knowledge to estimate the values in real life problems.

COURSE OUTCOMES

CO.NO	Upon successful completion of this course, students should have the knowledge and skills to:	Mapping
CO1	knowledge of various types of data, their organization and evaluation of summary measures such as non- central and central moments, measures of skewness and kurtosis.	BTL2, PO2
CO2	knowledge to conceptualize the probabilities of events including frequentist and axiomatic approach. simultaneously, they will learn the notion of conditional probability including the concept of Bayes' Theorem,	BTL3, PO2
CO3	knowledge related to concept of discrete and continuous random variables and their probability distributions including expectation and moments,	BTL4, PO2
CO4	knowledge related to concept of generating functions and weak law of large numbers.	BTL4,PO2

About this Course

Statistics is an important field of math that is used to analyze, interpret, and predict outcomes from data. Descriptive statistics will teach you the basic concepts used to describe data. This is a great beginner course for those interested in Data Science, Economics, Psychology, Machine Learning, Sports analytics and just about any other field. This paper deals with the situation where there is uncertainty and how to measure that uncertainty by defining the probability.

A. G & S. G Siddhartha Degree College of Arts and Science (Autonomous), Vuyyuru
(An Autonomous College in the jurisdiction of Krishna University, Machilipatnam)

STATISTICS	STATIIB	2021-22 Onwards	B.Sc.(MSCs)
-------------------	----------------	------------------------	--------------------

SEMESTER- I

PAPER- I

No. of Credits: 4

DESCRIPTIVE STATISTICS AND THEORY OF PROBABILITY

Unit- I

12L

Moments: Central and non-central moments and their inter-relationships, Sheppard's corrections for moments for grouped data. **Skewness:** Definition, measures of skewness by Karl Pearson's, Bowley's formulae and based on moments. **Kurtosis:** Definition, measures of kurtosis based on moments, Simple problems.

Unit- II

12L

Probability-I: Definitions of various terms - Random experiments, trial, sample space, mutually exclusive, exhaustive, equally likely, favourable and independent events. Definitions- Mathematical, Statistical and Axiomatic definitions of probabilities. Law of addition of probabilities for two events and extension of general law of addition of probabilities. Boole's inequality for n events and real-life problems.

Unit -III

12L

Probability-II : Conditional Probability-Definition - dependent and independence events, multiplication law of probability for two events, extension of multiplication law of probability. Pairwise independent events and conditions for mutual independence of n events and Baye's theorem and its applications and problems.

Unit- IV

12L

Random Variables: Univariate Random variables- Definition, Discrete and Continuous random variables - Probability mass function and probability density function with illustrations. Distribution function and its properties. Bivariate random variables- Definition, Discrete and Continuous bi-variate random variables- joint, marginal and conditional distributions- its properties. Distribution functions of the bivariate random variables and its properties. Independence of random variables, and simple problems.

UnitV:

12L

Mathematical Expectations: Definition, Mathematical expectation of function of a random variable, Properties of Expectations - Addition and Multiplication theorems of expectation. Properties of Variance and Covariance. Cauchy-Schwartz Inequality. Generating Functions- Definition of moment generating function (m.g.f), Cumulant generating function (c.g.f), Probability generating function (p.g.f) and Characteristic function (c.f) and statements of their properties with applications. Chebyshev's inequality and its applications. Statement of Weak Law of Large Numbers for identically and independently distributed (i.i.d) random variables with finite variance.

Text Book: Fundamentals of Mathematical Statistics, 12th Edition, 10th September 2020,

S. C. Gupta and V. K. Kapoor, Sultan Chand & Sons, New Delhi.

Recommended References books:

1. B.A/B.Sc. First Year Statistics(2010), Telugu Academy, Hyderabad.
2. Mathematical Statistics with Applications, 2009, K.M.Ramachandran and Chris P.Tsokos Academic Press(Elsevier), Haryana.
3. Probability and Statistics, Volume I, D.Biswas, New central book Agency (P) Ltd, New Delhi.
4. An outline of Statistical theory, Volume Two, 3rd Edition, 2010 (with corrections) A.M.Goon, M.K. Gupta, B.Dasgupta, The World Press Pvt.Ltd., Kolkata.
5. Sanjay Arora and Bansilal: New Mathematical Statistics, SatyaPrakashan, New Delhi.

Websites of Interest:

<http://onlinestatbook.com/rvls/index.html>

Co-Curricular Activities in the class:

1. Pictionary
2. Case Studies on topics in field of statistics
3. Snap test and Open Book test
4. Architectural - To be build the procedures
5. Extempore - Random concept to students
6. Interactive Sessions
7. Teaching through real world examples

Model Paper Structure

Section A: Answer FIVE questions out of EIGHT questions (5 x SM= 25 M)

Section B: Answer FIVE questions out of FIVE questions with internal choice .(5 x 10M = SOM)

A. G & S. G Siddhartha Degree College of Arts and Science (Autonomous), Vuyyuru
(An Autonomous College in the jurisdiction of Krishna University, Machilipatnam)

STATISTICS

STAT11B

2021-22 Onwards

B.Sc.(MSCs)

Model Paper

Section-A

Answer any FIVE of the following

5 x 5 = 25Marks

1. Show that for discrete distributions $\beta_1 > 1$ **(L-2, C0-1)**
2. State and prove addition theorem of probability for two events **(L-1, C0-2)**
3. If A and B are independent events, then prove that **(L-3, C0-2)**
 $i) \bar{A} \text{ and } B \text{ ii) } \bar{A} \text{ and } \bar{B}$ are also independent
4. Define the "distribution function" (or cumulative distribution function) of a random variable and state its essential properties. **(L-2, C0-3)**
5. Explain the concepts marginal and conditional probability distributions. **(L-2, C0-3)**
6. Show that the mathematical expectation of the sum of two random variables is the sum of their individual expectations. **(L-3, C0-3)**
7. Define moment generating function (m.g.f.) of a random variable X. If $M_X(t)$ is the m.g.f. of a random variable X about the origin, show that the moment μ_r' is given by **(L-1, C0-4)**
$$\mu_r' = \left[\frac{d^r}{dt^r} M_X(t) \right]_{t=0}$$
8. Explain the concept of "weak law of large numbers". **(L-2, C0-4)**

Section- B

Answer ALL the questions

5 x 10 = 50 Marks

9. A) Define moments. Establish the relationship between the moments about mean, (Central moments) in terms of moments about any arbitrary point and vice versa. **(L-3, C0-1)**
(OR)
B) The scores in Statistics of 250 candidates appearing at an examination have Mean= 39.72, variance= 97.80, 3rd central moment and fourth central moments are -114.18 and 28,396.14. It was later found on scrutiny that the score 61 of a candidate has been wrongly recorded as 51. Make necessary corrections in the given values of the mean and the central moments. **(L-3, C0-1)**

10. A) State and Prove Boole's inequality. (L-1, C0-2)
(OR)

B) For two events A and B, prove that (L-1, C0-2)

- (i) $P(A \cap B) = P(B) - P(A \setminus B)$ (ii) $P(A \cap B) = P(A) - P(A \setminus B)$
 (iii) if $B \subseteq A$ then $P(A \cap B) = P(A) - P(B)$ (iv) If $A \subseteq B$ then $P(A \cap B) = P(A)$

11. A) It is 8:5 against the wife who is 40 years old living till she is 70 and 4:3 against her husband now 50 living till he is 80. Find the probability that
 (i) Both will be alive, (ii) None will be alive,
 (iii) Only wife will be alive, (iv) Only husband will be alive,
 (v) Only one will be alive, (vi) At least one will be alive. (L-3, C0-2)

(OR)

B) A and B are two weak students of statistics and their chances of solving a problem in statistics correctly are 1/6 and 1/8 respectively. If the probability of their making a common error is 1/525 and they obtain the same answer, find the probability that their answer is correct. (L-3, C0-2)

12. A) Let X be a random variable with cumulative distribution function

$$F(x) = \begin{cases} 0, & \text{if } x < 0, \\ \frac{x^2 + 2}{4}, & \text{if } 0 \leq x < \frac{1}{2}, \\ \frac{x+1}{2}, & \text{if } \frac{1}{2} \leq x < \frac{3}{4}, \\ \frac{x+1}{2}, & \text{if } \frac{3}{4} \leq x < 1, \\ 1, & \text{if } x \geq 1 \end{cases}$$

Find

- (i) $P(0 \leq X < 1/4)$ (ii) $P(0 < X \leq 1/4)$ (iii) $P(0 \leq X \leq 1/4)$
 (iv) $P(0 < X < \frac{1}{2})$ (v) $P(X = 3/4)$ (L-5, C0-3)

(OR)

B) Two discrete random variables X and Y have the joint probability density function: $p(x, y) = \frac{Axe^{-x} p^y (1-p)^{x-y}}{y!(x-y)!}$, $y = 0, 1, 2, \dots$; $x = 0, 1, 2, \dots$

Where A, p are constants with $A, p > 0$ & $0 < p < 1$ are constants.

Find (i) The marginal probability density functions of X and Y.

(ii) The conditional distribution of Y for a given X and of X for a given Y.

(L-5, C0-3)

13. A) Explain the variance of a Linear Combination of Random Variables. (L-2, C0-4)

(OR)

B) (i) Define characteristic function of random variables and state its properties.
 (ii) State and Prove Chebychev's inequality. (L-2, C0-4)

A. G & S. G Siddhartha Degree College of Arts and Science (Autonomous), Vuyyuru
(An Autonomous College in the jurisdiction of Krishna University, Machilipatnam)

STATISTICS	STATIIB	2021-22 Onwards	B.Sc.(MSCs)
-------------------	----------------	------------------------	--------------------

SEMESTER-I

Practical - I: Descriptive Statistics

No of Credits: 1

CO.NO	Upon successful completion of this course, students should have the knowledge and skills to:	Mapping
CO1	draw the suitable diagram and graphs of the given sample data	P02
CO2	Analyze the uni-variate data using statistical techniques.	P02

List of Practicals

1. Diagrams & Graphs- Bar, Pie , Histogram, frequency polygon, and Ogive curves
2. Computation of measures of central tendency- Arithmetic Mean, Geometric mean and Harmonic Mean - Grouped Data.
3. Computation of measures of central tendency- Median, Mode and Partition Values - Grouped Data.
4. Computation of measures of Dispersion - Quartile Deviation, Mean Deviation, Standard Deviation, Variance and Coefficient of Variation - Grouped Data.
5. Computation of non-central, central moments, μ_1 and μ_2 and Sheppard's corrections for grouped data.
6. Computation of central moments, μ_1 and μ_2 and Sheppard's corrections when non -central moments are given.
7. Computation of Karl Pearson's coefficients, Bowley's coefficients of Skewness and coefficients of skewness based on moments - Grouped Data

Note: Training shall be on establishing formulae in Excel cells and derive the results. The excel output shall be exported to MS word for writing inference.

Reference Books

1. Practical Manual -Prepared by the Department Faculty Members
2. K.V.S. Sarma: Statistics Made Simple: Do it yourself on PC. PHI

Websites of Interest: <http://www.statsci.org/datasets.html>

**A.G& S.G.SIDDHARTHA DEGREE COLLEGE OF ARTS &
SCIENCE**

VUYYURU-521165, KRISHNA Dt., A.P.(Autonomous)

Accredited by NAAC with "A" Grade

2021-2022



DEPARTMENT OF STATISTICS

MINUTES OF BOARD OF STUDIES

EVEN SEMESTER

09-04-2022

Minutes of the meeting of BOS in Statistics for B.Sc(MSCs) Degree Courses of AG&SGSiddhartha Degree College of Arts & Science, Vuyyuru, held at 3.00 PM on 09- 04-2022.

N.V. SrinivasaRao

Presiding

Members Present:

- | | | |
|---|--------------------|--|
| 1) <u><i>N.V. Rao</i></u>
(N.V.SrinivasaRao) | Chairman | Head, Department of Mathematics,
AG & SG S Degree College. |
| 2) <u><i>P. R.</i></u>
(P. Ravi Kumar) | University Nominee | Department of Statistics,
Pavitra Degree College,
Machilipatnam. |
| 3) <u><i>G. Chakravarthy</i></u>
(G. Chakravarthy) | Subject Expert | Head. Department of Statistics,
P. B. Siddhartha College,
Vijayawada |
| 4) <u><i>D. Sunitha</i></u>
(D.Sunitha) | Member | Lecturer in Mathematics
AG & SG S Degree College. |
| 5) <u><i>A. Bhargavi</i></u>
(A.Bhargavi) | Member | Lecturer in Mathematics
AG & SG S Degree College. |
| 6) <u><i>Noor Mohammad</i></u>
(Noor Mohammad) | Member | Lecturer in Mathematics
AG & SG S Degree College. |
| 7) <u><i>K. Rajya Lakshmi</i></u>
(K. Rajya Lakshmi) | Member | Lecturer in Mathematics
AG & SG S Degree College. |

Agenda of B.O.S Meeting:

1. To discuss and recommend the Syllabi, Model Question Papers and Guidelines to be followed by question paper setters in Statistics for 2ndSemester as per the guidelines and instructions under APSCHE prescribed by Krishna University from the Academic Year 2021-22.
2. Discussed and recommended the teaching and evaluation methods for approval of Academic Council
3. Any other matter.

Resolutions.

1. To introduce new Syllabi, Model Question Papers and Guidelines to be followed by the question paper setters in Statistics of 2ndSemester from the Academic year 2021-22.
2. To recommend the teaching and evaluation methods to be followed under Autonomous status. The maximum marks for IA is 25 and SE is 75. Each IA written examination is of 1 Hr. duration for 15 marks. The tests will be conducted centrally. The average of two such IA is calculated for 15 marks. 5 marks will be allotted basing on Assignment and 5 marks are allotted for activity. There is no minimum passing for IA and there is no provision for improvement in IA. Even though the candidate is absent for two IA exams/obtain zero marks the external marks are considered (if he/ she gets 40 out of 75) and the result shall be declared as 'PASS' from the Academic year 2021-22.
3. Discussed and recommended for organizing seminars, Guest lecturers, Online Examinations and Workshops to upgrade the knowledge of students for Competitive Examinations for the approval of the Academic Council.

A.G. & S.G. Siddhartha Degree College of Arts & Science

Vuyyuru, Krishna District

Department of Statistics

Programme Specific Outcomes (PSOs)

- PSO1 : Apply the concepts, principles and methods of statistics to various fields of study
- PSO2 : Understand the importance and value of statistical principles and convert a problem description into testable research hypotheses
- PSO3 : Select appropriate statistical tools to investigate a research hypothesis.
- PSO4 : Perform data analysis by apply appropriate statistical methodology and interpret result in a variety of settings
- PSO5 : Compute statistical measures using software and programs.

**A. G & S. G Siddhartha Degree College of Arts and Science (Autonomous), Vuyyuru
(An Autonomous College in the jurisdiction of Krishna University, Machilipatnam)**

NAAC recredited at 'A' level

Autonomous -ISO 9001 – 2015 Certified

Course Code	STAT21C	Course Delivery Method	Class Room / Blended Mode - Both
Credits	4	CIA Marks	25
No. of Lecture Hours / Week	4	Semester End Exam Marks	75
Total Number of Lecture Hours	60	Total Marks	100
Year of Introduction :2021-22	Year of Offering:	Year of Revision: ----	Percentage of Revision: 0%

Title of the Course : Probability Distributions and Statistical Methods

Course Prerequisites: Students required basic knowledge in Calculus, Algebra and Probability.

Course Description: This course helps the students to familiarize students with the ways in which we talk about uncertainty and look at everyday situations in which probability arises. Also this course aims at providing basic knowledge about theoretical distribution models that can suit different phenomena of interest measured as variables in a continuum.

Course Objectives:

- 1) To enable the students to develop basic knowledge in theoretical Probability distributions
- 2) To provide understanding and applying standard continuous probability distribution to different situations.
- 3) To get the knowledge regarding qualitative factors
- 4) To understand the relation between quantitative factors
- 5) To make the estimated values using regression

Learning Outcomes: At the end of the course, the student will

- 1) Acumen to apply standard discrete probability distribution to different situations.
- 2) ability to handle transformed random variables and derive associated distributions.
- 3) The parameters describe an underlying physical setting in such a way that their value affects the distribution of the measured data.

S. No	Programme Outcomes

PO1.	Effective Communication: Speak, read, write and listen clearly in person and through electronic media in English and in one Indian language, and make meaning of the world by connecting people, ideas, books, media and technology
PO2.	Effective Citizenship: Demonstrate empathetic social concern and equity centred national development, and the ability to act with an informed awareness of issues and participate in civic life through volunteering.
PO3.	Ethics: Recognize different value systems including your own, understand the moral dimensions of your decisions, and accept responsibility for them.
PO4.	Environment and Sustainability: Understand the issues of environmental contexts and sustainable development
PO5.	Critical Thinking: Take informed actions after identifying the assumptions that frame our thinking and actions, checking out the degree to which these assumptions are accurate and valid, and looking at our ideas and decisions (intellectual, organizational, and personal) from different perspectives.
PO6:	Specialized Skills / Transferable Skills: Acquisition of communication and soft, analytical and technological skills that aid in enhancing
PO7.	Self-directed and Life-long Learning: Acquire the ability to engage in independent and life-long learning in the broadest context socio-technological changes

Course Outcomes:		
Course Outcome	Upon successful completion of this course, students should have the knowledge and skills to:	Programme Outcomes Mapping
CO 1	Develop the basic knowledge in Probability distribution and uncertainty conditions we apply standard discrete probability distributions to identify the probability values.	PO - 5
CO 2	Obtained the knowledge of applications on standard continuous distributions. Also get the knowledge in respect of usage in day-to-day life.	PO - 5
CO3	Analyse the qualitative data	PO - 6
CO 4	Statistically analyze the strengths of relationship between variables.	PO - 7
CO 5	To outline the vital area of regression models applicable in a wide variety of real time situations	PO - 7

Syllabus

Course Details

Unit	Learning Units	Lecture Hours
I	Theoretical Probability Discrete Distributions Rectangular, Binomial, Poisson, Negative Binomial, Geometric, Hyper Geometric distributions: Definitions, Means, Variances, M.G.F, C.G.F, P.G.F, additive property, limiting cases, memory less property if exists . Simple problems.	12

II	Theoretical Probability Continuous Distributions Rectangular, Normal, Exponential, Gamma, Beta Distributions: Definitions, Means, Variances, M.G.F, C.G.F, P.G.F, additive property, limiting cases, memory less property if exists . Simple problems.	12
III	Theory of Attributes: Notations, Dichotomy classification, class and class frequencies, order of classes and class frequencies. Ultimate class frequencies, relation between class frequencies. Consistency of data - Conditions for consistency of data for 2 and 3 attributes only. Independence of attributes- criterion of independence of two attributes. Association of attributes-Yule's coefficient of association and coefficient of colligation. Relationship between coefficient of association and colligation and simple problems.	12
IV	Correlation: Meaning, Types of Correlation, Measures of Correlation- Scatter diagram, Karl Pearson's Coefficient of Correlation, Rank Correlation coefficient (with and without ties), Bi-variate frequency distribution, correlation coefficient for bi-variate data and simple problems. Multiple and Partial Correlation- Coefficients of multiple and partial correlations, properties of multiple and multiple correlation coefficients, coefficient of multiple determination. simple problems	12
V	Curve fitting Principle of least squares, fitting of straight line, fitting of second degree polynomial or parabola. Fitting of power curve and exponential curves. Regression Analysis: Introduction, Linear Regression- Regression coefficients, properties of regression coefficients, angle between two lines of regression. Standard error of estimate (residual variance), Explained and unexplained variation, coefficient of determination and simple problems	12

Text Book:

Fundamentals of Mathematical Statistics, 12th Edition, Sep 2020, S. C. Gupta and V. K. Kapoor, Sultan Chand & Sons, New Delhi

Reference Books:

1. B.A/B.Sc. Second Year Statistics(2010) , Telugu Akademi, Hyderabad.
2. Mathematical Statistics with Applications, 2009, K.M.Ramachandran and Chris P.Tsokos Academic Press(Elsevier), Haryana .
3. Probability and Statistics, Volume I & II, D. Biswas, New central book Agency (P) Ltd, NewDelhi.
4. An outline of Statistical theory, Volume II,3rd Edition,2010(with corrections) A.M.Goon,M.K. Gupta, B.Dasgupta ,The World Press Pvt.Ltd., Kolakota.
5. Sanjay Arora and Bansi Lal:. New Mathematical Statistics, Satya Prakashan , New Delhi.

Websites of Interest:

<http://onlinestatbook.com/rvls/index.html>

Co-Curricular Activities in the class:

1. Pictionary
2. Case Studies on topics in field of statistics

3. Snap test and Open Book test
4. Architectural – To be build the procedures
5. Extempore – Random concept to students
6. Interactive Sessions
7. Teaching through real world examples

Model Question Paper Structure for SEE

Max.: 75 Marks

STAT21C

Min.Pass : 30 Marks

Model Paper Section A

Answer any FIVE of the following

5 x 5M = 25M

1. In Binomial distribution mean and variance are 4 and 3 respectively.
Find mode of the distribution. (Co – 1, L - 1)
2. Show that in Poisson distribution mean and variance are equal. (Co – 1, L - 6)
3. Write the properties of normal distribution. (Co – 2, L - 4)
4. Obtain the mean and variance of Beta distribution of 2nd kind. (Co – 2, L - 5)
5. Explain the types of correlation. (Co – 4, L - 2)
6. Define class and class frequency of an attribute with examples. (Co – 3, L - 1)
7. Write the properties of regression coefficients. (Co – 5, L - 4)
8. Explain the concept of rank correlation. (Co – 4, L - 2)

Section – B

Answer the following

5 x 10M =50M

9. a) Define Binomial distribution and derive the recurrence relation for central moments. (Co – 1, L - 1)
(OR)
- b) (i) A book contain 43 mistakes in 585 pages. Find the probability that there will be no mistake in randomly selected 10 pages of the book.
(ii) If a Poisson distribution such that $3P(x=1) = 2P(x=3)$. Find $P(2 \leq X \leq 5)$ (Co – 1, L - 1)
10. a) Show that mean, median and mode are equal in Normal distribution. (Co – 2, L - 6)
(OR)
- b) In a distribution exactly normal, 7% of the items are under 35 and 89% are under 63. What are the mean and standard deviation of the distribution. (Co – 2, L - 6)
11. a) Write the criteria for independence of three attributes. Find all the remaining class frequencies for the following set of frequencies. $N= 23713$, $(A) = 1618$, $(B) = 2015$, $(C) = 770$, $(AB) = 587$, $(AC) = 335$, $(BC) = 428$, $(ABC) = 158$ (Co – 3, L - 1)
(OR)
- b) The male population of a particular state is 250lakhs. The number of literate males is 20 lakhs and total number of male criminals is 26000. The number of literate male criminals is 2000. Do you find any association between literacy ad criminality. (Co – 3, L - 1)
12. a) State the Karl Pearson's correlation coefficient and prove that it has between -1 and +1. (Co – 4, L - 5)
(OR)

- b) Obtain the rank correlation coefficient of marks of 12 students in statistics and computer science given below (Co – 4, L - 5)

X	58	64	65	55	44	80	65	75	40	55	64	55
Y	52	48	45	62	45	68	62	82	44	45	74	62

13. a) Derive the regression equation of y on x (Co – 5, L - 3)

(OR)

- b) Fit the power curve of the type $y = ax^b$ to the following data (Co – 5, L - 3)

X	3	5	8	10	12	13
Y	17	41	94	139	191	220

A. G & S. G Siddhartha Degree College of Arts and Science (Autonomous), Vuyyuru
(An Autonomous College in the jurisdiction of Krishna University, Machilipatnam)

NAAC reaccredited at 'A' level

Autonomous -ISO 9001 – 2015 Certified

Title of the Course : Probability Distributions and Statistical Methods Lab

Offered to: B.SC (M.S.Cs.)

Course Code : STAP21C

Course Type: Core (P)

Year of Introduction: 2021-2022

Year of Revision: 2021-22

Percentage of Revision: 0%

Semester: II

Credits: 1

Hours Taught: 30periods

Max.Time: 2 Hours

Course Prerequisites (if any): Nil

S. No	Programme Outcomes
PO1.	Effective Communication: Speak, read, write and listen clearly in person and through electronic media in English and in one Indian language, and make meaning of the world by connecting people, ideas, books, media and technology
PO2.	Effective Citizenship: Demonstrate empathetic social concern and equity centred national development, and the ability to act with an informed awareness of issues and participate in civic life through volunteering.
PO3.	Ethics: Recognize different value systems including your own, understand the moral dimensions of your decisions, and accept responsibility for them.
PO4.	Environment and Sustainability: Understand the issues of environmental contexts and sustainable development
PO5.	Critical Thinking: Take informed actions after identifying the assumptions that frame our thinking and actions, checking out the degree to which these assumptions are accurate and valid, and looking at our ideas and decisions (intellectual, organizational, and personal) from different perspectives.

PO6:	Specialized Skills / Transferable Skills: Acquisition of communication and soft, analytical and technological skills that aid in enhancing
PO7.	Self-directed and Life-long Learning: Acquire the ability to engage in independent and life-long learning in the broadest context socio-technological changes

Course Outcomes:		
Course Outcome	Upon successful completion of this course, students should have the knowledge and skills to:	Programme Outcomes Mapping
CO 1	To fit a data into various theoretical probability distributions.	PO – 5
CO 2	Apply and Analyze the qualitative data	PO – 6
CO3	Identify the relations between the variables and estimate.	PO - 7

List of Practicals

1. (a) Fitting of Binomial distribution (Direct Method). (CO – 1)
- (b) Fitting of Binomial distribution (Recurrence Method). (CO – 1)
2. (a) Fitting of Poisson distribution (Direct Method). (CO – 1)
- (b) Fitting of Poisson distribution (Recurrence Method). (CO – 1)
3. (a) Fitting of Normal distribution (Areas Method). (CO – 1)
- (b) Fitting of Normal distribution (Ordinates Method). (CO – 1)
4. (a) Computation of Yule’s coefficient of association. (CO – 2)
- (b) Computation of Pearson’s and Tcherprows coefficient of contingency (CO – 2)
5. (a) Computation of correlation coefficient for ungrouped data. (CO – 3)
- (b) Computation of correlation coefficient for grouped data. (CO – 3)
6. (a) Fitting of a straight line by the method of least squares. (CO – 3)
- (b) Fitting of a parabola by the method of least squares. (CO – 3)
7. (a) Fitting of power curve $y = ax^b$ by the method of least squares. (CO – 3)
- (b) Fitting of exponential curves $y = ae^{bx}$ & $y = ab^x$ by the method of least squares. (CO – 3)
8. (a) Construction of regression lines for the ungrouped data. (CO – 3)
- (b) Construction of regression lines for the grouped data. (CO – 3)

Structure of Practical Paper

Total Marks: 50 Marks

- | | | |
|--|----------|---------------------------------------|
| (i) For Continuous Evaluation | : | 10 marks (Internal Evaluation) |
| (ii) For semester end Practical Examination | : | 40 marks (External Evaluation) |

**A.G& S.G.SIDDHARTHA DEGREE COLLEGE OF ARTS &
SCIENCE**

VUYYURU-521165, KRISHNA Dt., A.P.(Autonomous)

Accredited by NAAC with "A" Grade

2021-2022



DEPARTMENT OF HISTORY

MINUTES OF BOARD OF STUDIES

ODD SEMESTER

30-10-2021



AG&SG SIDDHARTHA DEGREE COLLEGE OF ARTS and SCIENCE
(AUTONOMOUS) VUYURU

ACADEMIC YEAR – 2021 - 2022

Minutes of the meeting of the Board of Studies in History of AG & SG Siddhartha Degree College of Arts & Science, Vuyuru, held at 10.00 A.M ON 30-10-2021 In the Department of History.

Sri. K.Kiran, HOD, History has Presided over the BOS meeting

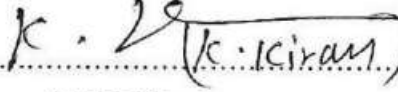
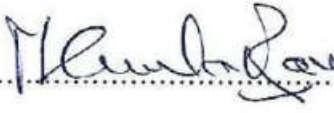
Members Present:

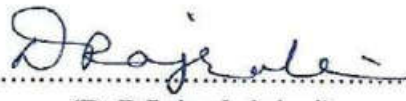
- 1)  Chairman
(Sri.K.Kiran) Head, Department of History
AG & SG S Degree College of Arts & Science
Vuyuru-521165
- 2)  University Head, Department of History
(Dr.M.Suseela Rao) Nominee Government Degree College
Mylavaram.
- 3)  Academic Council Head, Department of History
(Smt.N.jhansi) Nominee SDMSMahilaKalasala,
Vijayawada
- 4)  Academic Council Lecturer in History
(Dr.D.Rajya Lakshmi) Nominee Government Degree college
Avanigadda

AGENDA

1. To Review and recommend any changes in the syllabi , Model Question Papers and Guidelines of 1st, 3rd, and 5th Semesters of I, II and III Year B.A. History Papers for the Academic Year 2021-2022.
2. To Discuss and recommend the pattern of internal Assessment , Guidelines and Model Question Papers in 1st, 3rd and 5th Semesters of B.A Degree History papers for the Academic Year 2021-2022.
3. To Recommend the guidelines to be followed by the Question Paper Setters in Economics for the 1st, 3rd and 5th Semester-end exams.
4. To Recommend the teaching and evaluation methods to be followed under the Autonomous Status.
5. To Propose the panel of Question paper setters and Examiners.
6. To recommend the conduction of Value Added Course for I BA Students
7. To Suggest innovative methods of teaching.
8. Any other matter.

RESOLUTIONS:

1) It is Resolved to continue the same syllabi under CBC System approved by the Academic council of 2020- 2021 for 1st Degree in I Semester & III Degree in V Semester History papers, of B.A Classes.

The APSHE New syllabus was introduced in the I Semester of I Degree B.A from the Academic year 2020 – 2021 and in the III Semester of II Degree B.A From the Academic year 2021 – 2022.

- 2) Out of maximum 100 marks in each paper 30 marks shall be allocated for Internal Assessments regarding III and V Semesters.
 - A) To implement 30 marks for internal assessment and 70 marks for External Assessment from the academic year 2019-20 and that is also implemented to the III and V Semesters from 2020-21 Academic year and 2021 – 2022 Academic year also.
 - B) Out of these 30 marks, 20 marks are allocated for internal tests, 5 marks are allocated for assignment for III and V Semesters. The two tests will be conducted and average of these two tests shall be deemed as the marks obtained by a student, and remaining 5 marks are allocated for attendance.
- 3) **Out of maximum 100 marks 25 Marks shall be allocated for Internal Assessments Regarding the I Semester from the Academic year 2021 – 2022.**
 - A) **To implement 25 Marks for Internal Assessments and 75 Marks for External Assessment regarding the I Semester from the Academic year 2021 – 2022.**
 - B) **Out of these 25 marks, 20 Marks are allocated for internal tests, 5 marks are Allocated for assignment/ attendance Regarding the I Semester from the Academic year 2021 – 2022.**
- 4) Discussed and recommended the syllabi, Model question papers under CBC system and guidelines to be followed by the question paper setters of 1st semester of I , III and V semesters of B.A Classes for the Academic year 2021-2022.
- 5) To follow the teaching and evaluation methods, it is also resolved to use various other methods like Group discussions, Quiz, Organizing Seminars, Guest Lectures and

Workshops to upgrade the knowledge of the students and impart new skills of learning as frequently as possible.

- 6) 5. It is resolved to conduct Value added course in Travel & Tourism for I BA Students
- 7) Resolved to authorize the chairman of Board of studies to suggest the panel of paper setters and Examiners to the controller of Examinations as for the requirement.
7. It is resolved to follow further changes if any in the syllabus by the competent Authority.

K. J. [K. J. K. J.]
Chairman

AG & SG SIDDHARTHA DEGREE COLLEGE OF ARTS & SCIENCE VUYYURU

A.P- 521165

(An autonomous college in the jurisdiction of Krishna university, Machilipatnam)

HISTORY	HIS101	2021-22	B.A/HEP
----------------	--------	---------	---------

SEMESTER-1 Course -1
No. of Credits: 4

(ANCIENT INDIAN HISTORY & CULTURE FROM INDUS VALLEY CIVILIZATION TO 13TH CENTURY A. D) (NEW SYLLABUS)

Learning objectives:

1. To Identify the various kinds of sources and various stages of Indian civilization and religions like Buddhism and Jainism
2. To impart knowledge about religions like Buddhism and Jainism and Mouryan empire.
3. Inculcating awareness on ancient kingdoms of south Indian rulers.
4. Enlighten them with great Indian rulers like Gupta 's and Harshvardhan.
5. To provide the knowledge about the Cholas and Kakatiyas

Course Outcomes:

1. It encourages students to think explicitly about the aims of Indian history and culture
2. Acquire knowledge of Indian religions such Buddhism and Jainism. Acquainted with Indian kingship and culture -Mouryas and Satavahanas
3. Evaluate the south Indian administration and cultural contribution of Pallavas.
4. Ancient knowledge of golden age Guptas and cultural contribution oh Harsha.
5. Evaluate the administration of Cholas and greatness of Kakatiyas.

SYLLABUS

Unit - 1 **12 hrs**

- 1.1- Ancient Indian Civilization (from Circa 3000 BC to 6th BC):
 - 1.2 Indus Valley Civilization - Salient Features
 - 1.3 Vedic Age - Society, Polity, Economy, Culture during early and later Vedic period (On line)

Unit - II **12 hrs**

- 2.1- Ancient Indian History & Culture (6th Century BC to 2nd Century AD):
- 2.2- Doctrines and Impact of Jainism and Buddhism;
- 2.3- Mauryan Administration, Society, Economy & Culture - Ashoka's Dharma;
- 2.4- Kanishka's Contribution to Indian Culture (On line)

Unit - III **12 hrs**

- 3.1- History & Culture of South India (2nd Century BC to 8th Century AD):
- 3.2 Sangam Literature; Administration, Society, Economy and Culture under Satavahanas
- 3.3 Cultural contribution of Pallavas (On line)

Unit - IV **12 hrs**

- 4.1- India from 3rd century AD to 8th century AD: Administration, Society, Economy, Religion, Art, Literature and Science & Technology under Guptas - Samudragupta.
- 4.2- Cultural contribution of Harsha:
- 4.3 Arab Conquest of Sind and its Impact

Unit - V **12 hrs**

- 5.1- History and Culture of South India (9th century AD to 13th century AD):
- 5.2 Local Self Government of Cholas
- 5.3 Administration, Society, Economy and Culture under Kakatiyas - Rudramma Devi

CO-CURRICULAR ACTIVITIES AND ASSESSMENT METHODS:

Continuous Evaluation:

1. Monitoring the students progress of learning by Class Tests.
2. Map pointing
3. Projects, Assignments and Group Discussions, Enhances critical thinking skills and Personality.
4. Semester-End Examination: Critical indicator of students learning and teaching methods adopted by teachers throughout the semester

REFERENCES:

1. A.L. Basham, The Wonder That Was India
2. D.N.Jha, Ancient India
3. D.D.Kosambi, An Introduction to the Study of Indian History
4. D.P.Chattopadhyay, Science and Society in Ancient India
5. B.N.Mukherjee, The Rise and Fall of the Kushana Empire
6. K.A. NilakanthaShastri, A History of South India
7. R.C.Majumdar, K.K.Dutta&H.C.RoyChowdhuri (ed.), Advanced History of India
8. Kunkum Roy, The Emergence of Monarchy in North India: eighth to fourth centuries BC
9. RomilaThapar (et. al). India: Historical Beginnings and the Concept of the Aryan
10. M.L.K. Murthy, Pre-and Protohistoric Andhra Pradesh upto 500 B.C., New Delhi, 2003
- 11 K. Sathyanarayana, A Study of the History and Culture of Andhras

AG & SG SIDDHARTHA DEGREE COLLEGE OF ARTS & SCIENCE VUYYURU

A.P- 521165

(An autonomous college in the jurisdiction of Krishna university, Machilipatnam
HISTORY Model Question Paper
(NEW MODEL PAPER)
B.A/ HEP – I to VI semesters

Time : 3 hrs

Max. Marks : 75

PART – A

I. Answer any FIVE of the following : 5 x 5=25 M
(one Questions to be set from each unit)

1. Explain the Archeological Sources Co1 L2
2. Explain Mahavira and his teachings Co1 L2
3. Analyse Ashoka's contributions to Buddhism Co2 L3
4. Explain the role of Kanishka. Co2 L2
5. What are the main aspects of Sangam age Co3 L1
6. Estimate the invasions of SamudraGupta Co4 L4
7. Analyse Arab invasions. Co4 L3
8. Estimate the role of Raja Raja Chola Co5 L4

PART – B

II. Answer any FIVE of the following: 5 x 10= 50 M
(one Questions to be set from each unit)

1.
 - A) Explain about the Indus Valley Civilization. Co1 L2
OR
 - b.)What are the main features of Vedic civilization Co1 L1
2.
 - A).Explain Early life and teachings of Buddha. Co2 L2
OR
 - b.)Examine about Mauryan administration Co2 L3
3.
 - A)Explain the general conditions of Satavahana's. Co3 L2
OR
 - b.)Define the cultural contribution of Pallava's Co3 L1
4.
 - A)Illustrate the Golden age of Gupta's Co4 L2
OR
 - b.)Define the role of Harshavardhana in Indian History Co4 L1
5.
 - A) Explain Chola's administration Co5 L2
OR

b.)Examine the administration Of Kakatiyas Co5 L3

AG & SG SIDDHARTHA DEGREE COLLEGE OF ARTS & SCIENCE VUYYURU

A.P- 521165

(An autonomous college in the jurisdiction of Krishna university, Machilipatnam
(2021 – 2022)

PROGRAMME: THREE-YEAR B.A.

(With History, Economics and Political Science Disciplines)

Course Code: HIS-301

Domain Subject: History

Semester-wise Syllabus under CBCS

I Year B. A. – Semester – III

Course 3: MODERN INDIAN HISTORY & CULTURE (1764-1947 A. D)

Learning Outcomes:

After successful completion of this course, the student will be able to:

- Unearth the true nature of the British rule and its disastrous impact on Indian economy and society
- Gauge the disillusionment of people against the Company's rule even during the early 19th century
- Assess the causes and effects of Reformation movements and also inspire the public to overthrow inequalities of the present day society
- Rise above petty parochial issues after understanding the sacrificial saga of freedom struggle
- Evaluate the undercurrent of communal politics that led to India's partition and identify the enemies of India's integrity and sovereignty
- Visualize where places are in relation to one another through map pointing

AG & SG SIDDHARTHA DEGREE COLLEGE OF ARTS & SCIENCE VUYYURU

A.P- 521165

(An autonomous college in the jurisdiction of Krishna university, Machilipatnam
(2021 – 2022)

SEM-III

Syllabus:

- Unit - 1 Policies of Expansion –Warren Hastings, Cornwallis - Subsidiary Alliance & Doctrine of Lapse – Causes & Results of 1857 Revolt – Lytton, Rippon, Curzon
Social, Religious & Self-Respect Movements – Raja Rammohan Roy,
- Unit - II DayanandaSaraswathi, Swami Vivekananda, JyotibaPhule, Narayana Guru,
Periyar, Dr. B. R. Ambedkar
- Unit - III Causes for the growth of Nationalism - Freedom Struggle from 1885 to 1920:
Moderate Phase – Militant Phase: Vandemataram Movement-Home Rule
Movement
- Unit - IV Freedom Struggle from 1920 to 1947: Gandhiji’s Role in the National
Movement – Revolutionary Movement – Subhas Chandra Bose
- Unit - V Muslim League & the Growth of Communalism – Partition of India – Advent
of Freedom - Integration of Princely States into Indian Union – SardarVallabhai
Patel

References:

- 1 Anil Seal, Emergence of Indian Nationalism
- 2 Banerjee, Sekhar, From Plassey to Partition
- 3 Bipan Chandra, Rise and Growth of Economic Nationalism in India
- 4 Chandra, Bipan, et. al., India's Struggle for Independence
- 5 Bipan Chandra, Modern India
- 6 Joshi, P.C., Rammohun and the Forces of Modernisation in India
- 7 R.P.Dutt, India Today

Mandatory Co-Curricular Activity:

Map pointing should be a compulsory activity as it helps student to understand vividly and clearly than the text and should be made part of Internal Examination by allotting marks for this skill-based activity.

Suggested Co- Curricular Activities:

- @ Debates
- @ Viva voce interviews
- @ Quiz Programs
- @ Photo Album
- @ Recording local history
- @ Role Play of freedom struggle events
- @ Organizing photo exhibition on freedom fighters
- @ Celebration of important events/personalities
- @ Conducting Philately
- @ Examinations(Scheduled and surprise tests)
- @ Students may be asked to prepare a project on the difference between Mughal and British administration
- @ Encourage students to write their autobiography or biography of their inspiring Personalities

AG & SG SIDDHARTHA DEGREE COLLEGE OF ARTS & SCIENCE VUYYURU

A.P- 521165b (2021 – 2022)

(An autonomous college in the jurisdiction of Krishna university, Machilipatnam)

(2021 – 2022)

II BA.Semester – III (CBCS) Paper – III

Subject; History

Title of the Paper – MODERN INDIAN HISTORY & CULTURE (1764-1947 A. D)

Paper Code ; HIS-301 (w .e. f 2021 - 2022)

Pass Marks: 28

Time : 3Hrs

Max. Marks : 70

Model Question Paper

SECTION – A

Answer any TWO of the following

2x5=10 M

1. Home Rule League.
2. Swamy Vivekananda.
3. Identify the Places in Indian Map
A) Delhi B) Tanjavor C) Meerat D) Kanpur E) Ayodhya.
4. Identify the Places in Indian Map
A) Kashmir B) Hyderabad C) Junagadh D) Patna E) Bengal.

SECTION – B

Answer any FOUR of the following

4x15=60 M

5. Describe about the causes of 1857 Revolts
6. Give a brief account on contribution of Raja Rama mohan Rai to Socio – Religious movements.
7. Explain the role of Dr.B.R Ambedkar in Social Reforms.
8. Explain about the Swamy Vivekananda
9. Write an Essay on Vandematharam Movement.
10. Explain about the Non Cooperation Movement.
11. Explain the Role of Gandhiji in Indian National Movement.
12. Describe the Role of Valla bhai Patel in Integration of province states in India.

AG & SG SIDDHARTHA DEGREE COLLEGE OF ARTS & SCIENCE VUYYURU
A.P- 521165 (2021 – 2022)

(An autonomous college in the jurisdiction of Krishna university, Machilipatnam)

SUBJECT- History	HIS 301	II B.A
------------------	---------	--------

TITLE: MODERN INDIAN HISTORY & CULTURE (1764-1947 A. D)

Semester – III

Guidelines to the Paper Setter

Section	Unit – I	Unit – II	Unit – III	Unit - IV	Unit-V
A 5 Marks Questions	1	1	1	---	1
B 15 Marks Questions	2	2	1	2	1
Weightage	35	35	20	30	20

AG & SG SIDDHARTHA DEGREE COLLEGE OF ARTS & SCIENCE VUYYURU

A.P- 521165

(An autonomous college in the jurisdiction of Krishna university, Machilipatnam)
(2021 – 2022)

III BA History Syllabus:: Semester – V (CBCS) Paper – V

Title of the Paper :

Age of Rationalism and Humanism –The World Between 15th & 18th Centuries.

Paper Code; HIS-501C (w .e. f . 2020 - 2021)

No.of Hours per week:5

No. of Credits:4

Unit – 1

Feudalism -Geographical Discoveries: Causes – Compass & Maps – Portugal Leads and Western World Follows – Consequences;(15 Hrs)

Unit – II

The Renaissance Movement: Factors for the Growth of Renaissance – Characteristic Features - Transformation from Medieval to Modern World; Reformation & Counter Reformation Movements: The Background – Protestantism – Spread of the Movement– Counter Reformation– Effects of Reformation(20Hrs)

Unit - III

Emergence of Nation States: Contributory Factors - England and other Nation States – Impact due to the Emergence of Nation States.; Age of Revolutions: The Glorious Revolution (1688) – Origin of Parliament – Constitutional Settlement – Bill of Rights – Results(15Hrs)

Unit – IV

Age of Revolutions: The American Revolution (1776) – Opening of New World – Causes – Course – Declaration of Independence, 1776 – Bill of Rights, 1791 – Significance(20Hrs).

Unit – V

Age of Revolutions: The French Revolution (1789) – Causes - Teachings of Philosophers - Course of the Revolution – Results(20Hrs)

References:

- 1 Burke, Peter, the Renaissance
- 2 C.J.H. Hayes, Modern Europe up to 1870
- 3 C.D. Hazen, Modern Europe up to 1945
- 4 Christopher Hill, From Reformation to Industrial Revolution
- 5 Elton, G.R., Reformation Europe, 1517-1559
- 6 Ferguson, the Renaissance
- 7 Gilmore, M.P., the World of Humanism, 1453-1517
- 8 Hilton, Rodney, Transition from Feudalism to Capitalism
- 9 J.H.Parry, the Age of Renaissance
- 10 J.N.L. Baker, History of Geographical Discoveries and Explorations
- 11 the New Cambridge Economic History of Europe, Vol. I, VII.

AG & SG SIDDHARTHA DEGREE COLLEGE OF ARTS & SCIENCE VUYYURU
A.P- 521165

(An autonomous college in the jurisdiction of Krishna university, Machilipatnam)

(2021 – 2022)

III BA.Semester – V (CBCS) Paper – V

Subject; History

Title of the Paper – Age of Rationalism and Humanism –The World Between 15th& 18th Centuries.

Paper Code ; HIS-501C (w .e. f 2020 - 2021)
Time : 3Hrs

Pass Marks: 28
Max. Marks : 70

Model Question Paper

SECTION – A

Answer any TWO of the following

2x5=10 M

1. Geographical Discoveries
2. Counter Reformation
3. Boaston Tea Party
4. Reign of Terror

SECTION – B

Answer any FOUR of the following

4x15= 60 M

5. Analyse the features Feudalism
6. Explain the important features of Renaissance
7. What is Reformation Movement and its significance
8. Describe the causes for the emergence of Nation States
9. Give a brief account of Glorious Revolution
10. Discuss about the causes of American Revolution
11. Write an essay on causes for the French Revolution
12. Estimate the rule of Directory in France.

AG & SG SIDDHARTHA DEGREE COLLEGE OF ARTS & SCIENCE VUYYURU
A.P- 521165

(An autonomous college in the jurisdiction of Krishna university, Machilipatnam)

(2021 – 2022)

SUBJECT- History	HIS 501C	III B.A
------------------	----------	---------

TITLE: Age of Rationalism and Humanism –The World Between 15th& 18th Centuries.

Semester – V

Guidelines to the Paper Setter

Section	Unit – I	Unit – II	Unit – III	Unit - IV	Unit-V
A 5 Marks Questions	1	1	-	1	1
B 15 Marks Questions	1	2	2	1	2
Weightage	20	35	30	20	35

AG & SG SIDDHARTHA DEGREE COLLEGE OF ARTS & SCIENCE VUYYURU
A.P- 521165

(An autonomous college in the jurisdiction of Krishna university, Machilipatnam)

(2021 – 2022)

III BA. Semester – V (CBCS) Paper – VI

Subject:: History : Syllabus - Title of the Paper – History & Culture of Andhra Desa (from 12th to 19th Century A.D)

Paper Code : HIS-502C (w .e. f 2020 - 2021)

No.of Hours per week:5

No.of Credits:4

Unit – 1

Andhra during 12th& 13th Centuries A.D.: Kakatiyas – Origin & its Antecedents – Administration – Social & Economic Life – Industries & Trade - Promotion of Literature and Culture – Architecture & Sculpture – Decline; The Age of Reddy Kingdoms: Patronage to Literature – Trade & Commerce.(20Hrs)

Unit – II

Andhra between 14th & 16th Centuries A.D.: Vijayanagara Empire: Polity, Administration, Society & Economy – Sri Krishna Devaraya and his contribution to Andhra Culture – Development of Literature & Architecture – Decline and Downfall.(15Hrs)

Unit - III

Andhra through 16th& 17th Centuries A.D.: Evolution of Composite Culture – The QutbShahis of Golkonda – Origin & Decline – Administration, Society & Economy –Literature & Architecture.(15Hrs)

Unit – IV

The 18th& 19th Centuries in Andhra: East India Company’s Authority over Andhra – Three Carnatic Wars – Occupation of Northern Circars and Ceded Districts –Early Uprisings – Peasants and Tribal Revolts.(20Hrs)

Unit – V

The 18th& 19th Centuries in Andhra: Impact of Company Rule on Andhra – Administration – Land Revenue Settlements – Society – Education - Religion – Impact of Industrial Revolution on Economy – Peasantry & Famines – Contribution of Sir Thomas Munroe, C. P. Brown & Sir Arthur Cotton – Impact of 1857 Revolt in Andhra.(20Hrs)

References:

- 1 BalenduSekharam, TheAndhras Through the Ages
- 2 K. Sathyanarayana, A Study of the History and Culture of Andhras
- 3 Mallampalli Soma SekharaSarma, History of the ReddiKindogms
- 4 K. A.N.Sastry, A History of South India
- 5 H.K.Sherwani, History of the KutubShahi Dynasty
- 6 P.R.Rao, History of Modern Andhra
- 7 KhandavalliLakxmiranjanam&BalenduSekharam
- 8 SuravaramPratap Reddy
- 9 B.S.L.HanumantaRao
- 10 I.K.Sarma, *Early Historic Andhra Pradesh, 500 B.C.-624 A.D.*, New Delhi, 2008
- 11 B. Rajendra Prasad, *Early Medieval Andhra Pradesh, A.D.624 -1000 A.D.*, New Delhi, 2009
- 12 C. SomasundaraRao, *Medieval Andhra Pradesh, A.D. 1000 -1324 A.D.*, New Delhi, 2011
- 13 R. Soma Reddy, *Late Medieval Andhra Pradesh, A.D. 1324-1724 A.D.*, New Delhi, 2014

AG & SG SIDDHARTHA DEGREE COLLEGE OF ARTS & SCIENCE VUYYURU,A.P- 521165

(An autonomous college in the jurisdiction of Krishna university, Machilipatnam)

III BA. Semester – V (CBCS) Paper – VI

Subject:: History

Title of the Paper – History & Culture of Andhra Desa (from 12th to 19th Century A.D)

Paper Code; HIS-502C (w .e. f 2020 - 2021)

Pass Marks: 28

Time : 3Hrs

Max. Marks: 70

Model Question Paper

SECTION – A

Answer any TWO of the following 2x5=10

1. Rudrama Devi
2. Battle of Tallikota
3. Abdul Hasan Tanisha
4. Sir Arthur Cotton

SECTION – B

Answer any FOUR of the following 4x15=60

5. Write an essay on Socio-Economic and Cultural conditions of Kakatiyas
6. Discuss the glory of Vijayanagara Empire
7. Briefly explain the Administrative system of Qutub Shahis
8. Write about the general conditions of Andhra in 17th Century
9. Give a brief account of Carnatic Wars in Deccan
10. Explain about the Acquisition of Northern Circars by British
11. Describe the greatness of Thomas Munroe
12. Estimate the impact of 1857 Revolt in Andhra.

**AG & SG SIDDHARTHA DEGREE COLLEGE OF ARTS & SCIENCE VUYYURU
A.P- 521165**

(2021 – 2022)

(An autonomous college in the jurisdiction of Krishna university, Machilipatnam)

SUBJECT- History	HIS 502C	III B.A
------------------	----------	---------

TITLE: History & Culture of Andhra Desa (from 12th to 19th Century A.D)

Semester – V

Guidelines to the Paper Setter

Section	Unit – I	Unit – II	Unit – III	Unit - IV	Unit-V
A 5 Marks Questions	1	1	1	-	1
B 15 Marks Questions	1	1	2	2	2
Weightage	20	20	35	30	35

**A.G& S.G.SIDDHARTHA DEGREE COLLEGE OF ARTS &
SCIENCE**

VUYYURU-521165, KRISHNA Dt., A.P.(Autonomous)

Accredited by NAAC with "A" Grade

2021-2022



DEPARTMENT OF HISTORY

MINUTES OF BOARD OF STUDIES

EVEN SEMESTER

31-03-2022



A.G & S.G SIDDHARTHA DEGREE COLLEGE OF ARTS AND SCIENCE-VUYYURU

(An Autonomous College in the Jurisdiction of Krishna University)
Accredited at the level 'A' by the NAAC

Sponsors: Siddhartha Academy of General & Technical Education

DEPARTMENT OF HISTORY

Minutes of the meeting of Board of Studies in Political Science of A.G. &S.G Siddhartha Degree College of Arts & Science, Vuyyuru held at 10:30 A.M On 31/03/2022 in the Department of History

Members Present		
Name of the Member	Role	Signature
Sri. T.Narasimha rao, HOD, Dept. of History, A.G & S.G Siddhartha Degree College of Arts & Science, Vuyyuru-521165.	Chairman	
Dr.M.Suseela Rao, Head, Department of History Government Degree College, Thiruvuru	University Nominee, Krishna University	
Dr.D.Rajyalakshmi, Lecturer in History Government degree College, Avunigadda	Subject Expert	
Smt.N.Jhansi, Head, Department of History S.D.M.S Mahila Kalasala, Vijayawada.	Subject Expert	

AGENDA

1. To review and recommend changes to syllabi, model paper and guidelines in the 2nd, 4th and 6th semesters of B.A
2. To discuss about and recommend the pattern of assessment i.e., internal and external assessment percentage to be followed for Third Semester from academic year 2021-2022
3. To recommend the guidelines to be followed by the Question Paper Setters in History for all semester-end exams.
4. To recommend the teaching and the evaluation methods to be followed under the Autonomous System.
5. To Suggest innovative methods of teaching
6. To propose the panel of Question Paper Setters and Examiners.

RESOLUTIONS

Following resolutions are made in the Board of Studies in History :

- 1) It is resolved to include Later Medieval Indian History in the place of Medieval Indian History for Semester-II for the 1st Degree from the Academic Year 2021-2022.
- 2) It is resolved to introduce history and culture of Andhra India in the place of Social Reform movement and freedom struggle for semester-IV for the 2nd Degree from the Academic Year 2021-2022.
- 3) It is resolved to introduce History of Modern World for semester-IV for the 2nd Degree from the Academic Year 2021-2022.
- 4) To continue with the existing syllabi for 6th semester without any change for the Academic Year 2021-2022.
- 5) To adapt 25 marks for internal assessment and 75 marks for external assessment for 1st Degree and 30 marks for internal assessment and 70 marks for external assessment for 2nd and 3rd year Degree from the Academic Year 2021-2022.
- 6) To follow the new model question paper from the Academic Year 2021-2022 for all the B.A Students
- 7) To adapt the following teaching and evaluation methods:

Teaching Methods:

Besides the conventional methods of teaching, it is also resolved to use various other methods like group discussions, quiz, developing power point presentation etc., for the better understanding of the contents.

Evaluation Method for Internal Theory Examination for 1st B.A students

First Internal Exam	Second Internal Exam	Average	Attendance	Total
A	B	$C=(A+B) / 2$	D	(C+D)
20 Marks	20 Marks	20 Marks	5 Marks	25 Marks

Evaluation Method for Internal Theory Examination for 2nd and 3rd B.A students

First Internal Exam	Second Internal Exam	Average	Assignment	Attendance	Total
A	B	$C=(A+B) / 2$	D	E	(C+D+E)
20 Marks	20 Marks	20 Marks	5 Marks	5 Marks	30 Marks

- 8) Semester End Examinations:
- 9) The maximum marks of sem-end examinations for 1st B.A are 75 and for 2nd and 3rd B.A students are 70 Marks from the Academic Year 2021-2022 for all the B.A Students and the duration of the examination shall be 3 Hours.
- 10) To Organize Seminars, Guest Lectures and Workshops to upgrade the knowledge of the students and to impart new skills of learning as frequently as possible.
- 11) To authorize the chairman of board of studies to suggest the panel of paper setters and examiners to the controller of examinations as per the requirement.

A.G and S.G. Siddhartha Degree College of Arts & Science, Vuvvuru - 521165.

(An Autonomous College in the jurisdiction of Krishna University :Machilipatnam)

PROGRAMME: THREE-YEAR BA

STRUCTURE OF HISTORY SYLLABUS UNDER CBCS FOR 3-YEAR B.A. PROGRAMME

YEAR	CODE	SEM	Name of course <i>(each course consists 5 units with each unit having 12 hours of class work)</i>	Hours/week	Credits	Marks	
						Internal	Sem end
I		I	Ancient Indian history and culture (From Indus valley Civil to 13 century(A.D)	5	4	25	75
		II	Medieval Indian history and Culture(1206 A.D to 1764 A.D)	5	4	25	75
II		III	Modern Indian history and culture(1764-1947 A.D	5	4	30	70
		IV	History and Culture of Andhra(from 1512 to1956 A.D)	5	4	30	70
		V	History of modern world(from 15 th century	5	4	30	70

A.G and S.G.Siddhartha Degree College of Arts & Science, Vuyyuru.

An autonomous college in the jurisdiction of Krishna University :Machilipatnam

HISTORY	HIS-201C	2020-21	B.A/HEP
----------------	-----------------	----------------	----------------

SEMESTER-II

Course -II

No. of

Credits: 4

MEDIEVAL INDIAN HISTORY & CULTURE (1206 A.D to 1764 A.D) (NEW SYLLABUS)

Learning objectives:

1. To provide knowledge about the Delhi sultanates
2. To impart the knowledge about the Islam religion and greatness of Vijayanagara empire.
3. To make the students to understand the greatness of the Mughal rulers.
4. To provide the information of the administration and cultural contribution of the Mughals.
5. To enlighten the students regarding the advent of the Europeans

Course Outcomes:

1. Acquire the knowledge of Delhi sultanates.
2. Analyze the socio, religious consciousness in India
3. Acquire knowledge about the Mughal rulers and their policies.
4. Students will learn to understand, analyze and evaluate the administration and cultural aspects of Mughals
5. Acquainted with the advent of the Europeans and their settlements in India.

Unit- I **15 hours**

Impact of Turkish Invasions– Balban, Allauddhin Khilji, Md. Bin Tughlaq- Administration, Society, Economy, Religion and Cultural developments under Delhi Sultanate (from 1206to 1526 AD)

Unit – II **15 hours**

Impact of Islam on Indian Society and Culture–Bhakti Movement; Administration, Society, Economy, Religion and Cultural developments under Vijayanagara Rulers

Unit – III **15 Hours**

Emergence of Mughal Empire – Babur – SurInterregnum-Expansion & Consolidation of Mughal Empire – Akbar, Jahangir, ShahJahan, Aurangazeb.

Unit – IV **15 hours**

Administration, Economy, Society and Cultural Developments under the Mughals – Disintegration of Mughal Empire -Rise of Marathas under Shivaji

Unit _ V **15 hours**

India under Colonial Hegemony: Beginning of European Settlements-Anglo- French Struggle – Conquest of Bengal by EIC

CO-CURRICULAR ACTIVITIES AND ASSESSMENT METHODS:

Continuous Evaluation:

1. Monitoring the student's progress of learning by Class Tests.
2. Map pointing
3. Projects, Assignments and Group Discussions, Enhances critical thinking skills and Personality.
4. Semester-end Examination: Critical indicator of students learning and teaching methods adopted by teachers throughout the semester

TEXT BOOKS:

1. Prachina Bhasha Desa Charitra – Si.K. Krishna Reddy.
2. Bharatha Desa Charitra – Telugu Academy

REFERENCES:

1. Chandra, S History of Medieval India(800– 1700)
2. Chattopadhyay, B.D The Making of Early Medieval India. (Delhi, 1994)
3. Habib, Irfan, Medieval India: The Study of a Civilization
4. Habibullah, A.B.M, The Foundation of Muslim Rule in India
5. Kumar Sunil, The Emergence of the Sultanate of Delhi
6. Nizami, K.A. Some Aspects of Religion and Politics in India in the 13th c
7. K.A. Nilakanta Sastri, A History of South India from Prehistoric Times to the Fall of Vijayanagara
8. K.A. Nilakanta Sastri, The Cholas
9. Shireen Moosvi, The Economy of the Mughal Empire
10. Stein, B Peasant, State & Society in Medieval South India
11. Yazdani, G. (ed) The Early History of the Deccan
12. R.C. Majumdar, The Age of Imperial Kanauj
13. R. Soma Reddy, *Late Medieval Andhra Pradesh, A.D. 1324-1724 A.D.*, New Delhi, 2014
14. Harbans Mukhia, The Mughals of India
15. C.A. Bayly, Indian Society and the Making of the British Empire

A.G and S.G. Siddhartha Degree College of Arts & Science, Vuyyuru - 521165.

An autonomous college in the jurisdiction of Krishna University, Machilipatnam, A.P., India

MODEL PAPER

Medieval Indian History and Culture (1206 A.D to 1764 A.D)

HISTORY Model Question Paper

(NEW MODEL PAPER)

B.A/ HEP – II

Subject Code: HIS-201C

Time : 3 hrs

Max. Marks : 75

PART– A

D) Answer any FIVE of the following: 5 x 5=25M

1. Explain the role of Balban Co1 L2
2. Illustrate the work of Razia sultan Co1 L2
3. Analyse the contributions of Ashtadiggaja's Co2 L3
4. Analyse the role of Jahangir .Co3 L3
5. How Aurangzeb was responsible for the downfall of the mughal empire Co3 L1
6. Examine the role of Tajmahal in the past and present Co5 L3
7. Explain the portuguese establishments in India Co5 L2
8. What is the role of Dupleix as governor Co5 L1

PART – B

II. Answer any FIVE of the following: 5 x 10= 50M

(one Questions to be set from each unit)

1. A) Explain the administration of the Allauddinkhilji. Co1 L2

OR

b.)What are the main reforms of Mohammad bin tughlaq Co1 L1

2. A) Explain the Bhakti movement Co2 L2

OR

b.)Define the characteristics of Vijayanagaraempire Co2 L1

3. A) Explain the administration of shersha Co3 L2

OR

b.)What are the religious reforms of Akbar Co3 L1

4. A) Analyse the administration of Mughals Co4 L3

OR

b.) Explain Shivaji'sadministration Co4 L2

5. A) Illustrate the anglo - French conflicts Co5 L2

OR

b.)What was the role of Robert cliveas governor Co5 L1

A.G and S.G. Siddhartha Degree College of Arts & Science, Vuvvuru - 521165.

An autonomous college in the jurisdiction of Krishna University :Machilipatnam

HISTORY	HIS-401C	2021-22	B.A/HEP
----------------	-----------------	----------------	----------------

SEMESTER – IV

IV

Course:

No. of
Credits: 4

HISTORY & CULTURE OF ANDHRA (FROM 1512 TO 1956 AD)
(NEW SYLLABUS)

Learning objectives:

1. To give clear picture of Qutubshahis
2. Focussing awareness on advent of europeans and their rule in Andhra
3. To give knowledge about social and religious reforms
4. To infuse the Nationalistic feelings among the studenta
5. To provide information about the AP state formation(1953) Andhra Pradesh formation

Course Outcomes:

1. Known about Nizams of Hyderabad
2. Learnt the impact of British on Andhra - Monroe- C. P Brown, Sir Arthur Cotton
3. They were aware of social reformers and their contribution
4. Acquired knowledge about the national leaders and their ideologies
5. Acquainted with the knowledge of A. P state formation & Andhra Pradesh formation

Unit – 1

12 hrs

- 1.1-Andhra through 16th& 19th Centuries AD:
- 1.2- Evolution of Composite Culture - The QutbShahis of Golkonda –Administration, Society &Economy – Literature & Architecture;
- 1.3- Advent of European and settlements in Andhra - Occupation of Northern Circars and Ceded Districts – Early revolts against the British

Unit – II

12 hrs

- 2.1 Andhra under British rule: Administration – Land Revenue Settlements – Society – Education - Religion – Impact of Industrial Revolution on Economy – Peasantry & Famines – Contribution of Sir Thomas Munroe & C. P. Brown – Impact of 1857 Revolt in Andhra

Unit – III

12 hrs

- 3.1- Social Reform & New Literary Movements: Kandukuri Veeresalingam, Raghupathi Venkata Rathnam Naidu, Guruzada Apparao, Komarraju Venkata Laxmana Rao.
- 3.2-New Literary Movements: Rayaprolu Subbarao, Viswanatha Sathyanarayana, Gurram Jashua, Boyi Bhemanna, Sri Sri

Unit – IV**12 hrs**

4.1- Freedom Movement in Andhra (1885-1947):

4.2- Vandemataram Movement– Home Rule Movement in Andhra - Non-Cooperation Movement – Alluri Seetarama Raju & Rampa Revolt (1922-24) - Civil Disobedience Movement – Quit India Movement

Unit – V**12 hrs**

5.1 Movement for separate Andhra State (1953) and AP (1956):

5.2 Causes – Andhra Maha Sabha –Conflict between Coastal Andhra & Rayalaseema – Sri Bagh Pact – work of various Committees – Martyrdom of Potti Sriramulu – Formation of separate Andhra State (1953);

5.3 Movement for formation of Andhra Pradesh (1956):

5.4 Visalandhra Mahasabha – Role of Communists – States Reorganization Committee – Gentlemen’s Agreement – Formation of Andhra Pradesh

CO-CURRICULAR ACTIVITIES AND ASSESSMENT METHODS:

Continuous Evaluation:

1. Monitoring the progress of student’s learning, Class Tests
2. Map pointing
3. Projects, Assignments and Group Discussions, Enhances critical thinking skills and Personality.
4. Semester-end Examination: Critical indicator of students learning and teaching methods adopted by teachers throughout the semester

TEXT BOOKS:

1. Bhasha Desa Charitra – Madhya yugam- Si.K. Krishna Reddy.
2. BharathaDesaCharitra – Telugu Academy

REFERENCES:

1. H.K.Sherwani, History of the KutubShahi Dynasty
2. K. Sathyanarayana, A Study of the History and Culture of Andhras
3. B. KesavaNarayana, Political and Social Factors in Modern Andhra
4. K.V.NarayanaRao, The Emergence of Andhra Pradesh
5. M. VenkataRangaiah, The Freedom Struggle in Andhra Pradesh
6. P.R.Rao, History of Modern Andhra
7. SarojiniRegani, Highlights of Freedom Movement
SarojiniRegani.
8. V. Ramakrishna, Social Reform Movement in Andhra
9. B. KesavaNarayana, Modern Andhra & Hyderabad – 1858 – 1956 A.D., 2016 11
K. Koti Reddy, History of Modern Andhra, Telugu Academy, Hyderabad

A.G and S.G. Siddhartha Degree College of Arts & Science, Vuyyuru - 521165.

An autonomous college in the jurisdiction of Krishna University, Machilipatnam, A.P., India

MODEL PAPER

History and Culture of Andhra Desha(1512 A.D to 1956 A.D)

HISTORY Model Question Paper

(NEW MODEL PAPER)

B.A/ HEP – IV

Subject Code:HIS 401C

Time : 3 hrs

Max. Marks : 70

PART– A

I) Answer any TWO of the following : 2 x 5=10M

1. Explain the battle of Chanderi Co1 L2
2. What are the land reforms of British Co2 L1
3. Explain the contribution of C. P. Brown Co2 L2
4. What is the role Alluri sitaramaraju Co4 L1.

PART – B

II. Answer any FOUR of the following: 4 x 15= 60M

5. What are the general conditions of Qutubshahis. Co1 L1
6. How the British acquired Northern Circars Co1 L1
7. What is the impact of industrial revolutionary in Andhra Co2 L1
8. What are the revenue reform introduced by Sir Thomas Monroe Co2 L1
9. Explain about Vandemataram movement in Andhra Co4 L2
10. Examine the Non cooperation movement in Andhra Co4 L2
11. What was the role played by Potti sriramulu in the formation of Andhra state Co5 L1
12. Explain the formation of Andhra Pradesh Co5 L2

Section	Unit – I	Unit – II	Unit – III	Unit - IV	Unit-V
A 5 Marks Questions					
B 15 Marks Questions					
Weightage					

A.G and S.G. Siddhartha Degree College of Arts & Science, Vuyyuru - 521165.
An autonomous college in the jurisdiction of Krishna University :Machilipatnam

HISTORY		2021-22	B.A/HEP
----------------	--	----------------	----------------

SEMESTER –IV

Course :V

No. of

Credits: 4

HISTORY OF MODERN WORLD (From 15th Cent. AD to 1945 AD) (NEW SYLLABUS)

Learning objectives:

1. To impart knowledge about Renaissance and reformation
2. To give information about the glorious Revolution and American revolution
3. To make them aware of unification of Italy and Germany
4. To know about world wars and their affects
5. To provide information about the role of league of Nations and U. N. O

Course Outcomes:

1. Acquired the knowledge about the evolution of changes in the modern europe
2. Learnt about revolution and their impact on world
3. Had idea about the unification of Italy and Germany
4. Learnt lessons from world war 1&2
5. Gained knowledge about the work and importance of international organizations.

Unit – 1

12hrs

Transformation from Medieval to Modern Era – Chief Characteristics; Glorious Revolution (1688) – Origin of Parliament Bill of Rights – Results

Unit – II

12hrs

American Revolution (1776); French Revolution (1789) – Causes, Course and Results

Unit - III

12 hrs

Unification of Italy; Unification of Germany

Unit – IV

12hrs

Communist Revolution in Russia; World War I: Causes – Results of the War – Paris Peace Conference; League of Nations

Unit - V

12hrs

World War II: Causes, Fascism & Nazism – Results; The United Nations Organization: Structure, Functions and Challeng

Co-curricular activities and Assessments Methods:

Continuous Evaluation:

1. Monitoring the progress of student’s learning, Class Tests
2. Map pointing
3. Projects, Assignments and Group Discussions, Enhances critical thinking skills and Personality.
4. Semester-end Examination: Critical indicator of students learning and teaching methods adopted by teachers throughout the semester

TEXT BOOK:

1. BhashaDesaCharitra – Madhya yugam- Si.K. Krishna Reddy.
2. BharathaDesaCharitra – Telugu Academy

References:

- 1 Burke, Peter, The Renaissance
- 2 C.J.H. Hayes, Modern Europe up to 1870
- 3 C.D. Hazen, Modern Europe up to 1945
- 4 Christopher Hill, From Reformation to Industrial Revolution
- 5 Elton, G.R., Reformation Europe, 1517-1559
- 6 Ferguson, The Renaissance
- 7 Gilmore, M.P., The World of Humanism, 1453-1517
- 8 Hilton, Rodney, Transition from Feudalism to Capitalism
- 9 J.H. Parry, The Age of Renaissance
- 10 J.N.L. Baker, History of Geographical Discoveries and Explorations
- 11 The New Cambridge Economic History of Europe, Vol. I, VII

A.G and S.G. Siddhartha Degree College of Arts & Science, Vuyyuru - 521165.
An autonomous college in the jurisdiction of Krishna University, Machilipatnam, A.P., India

MODEL PAPER

History of Modern World

HISTORY Model Question Paper
(NEW MODEL PAPER)
B.A/ HEP – IV

Subject Code: HIS402 C

Time: 3 hrs

Max. Marks : 70

PART–A

I) Answer any TWO of the following: 2 x 5=10M

1. What was the role of Martin Luther in reformation Co1 L1
2. Explain the contribution of Bismark Co3 L2
3. Explain the role of Lenin in Russian revolution Co4 L2
4. What is Fascism Co5 L1.

PART – B

II. Answer any FOUR of the following: 4 x 15= 60M

5. What is Glorious revolution Co1 L1
6. Explain about American Revolution Co2 L2
7. Analyse the causes and results of French revolution Co2 L3
8. Explain the unification of Italy Co3 L2
9. Examine various factors of Unification of Germany Co3 L3
10. Explain about Russian revolution Co4 L2
11. What are the causes and results of world war I Co4 L1
12. What is the role of U. N. O Co5 L1

Section	Unit – I	Unit – II	Unit – III	Unit - IV	Unit-V
A 5 Marks Questions					
B 15 Marks Questions					
Weightage					

A.G and S.G. Siddhartha Degree College of Arts & Science, Vuyvuru - 521165.
An autonomous college in the jurisdiction of Krishna University :Machilipatnam

III BA Semester – VI (CBCS) Paper – VII (General Elective)

**Subject; History, Syllabus, Title of the Paper – History of Modern Europe (from 19th
Century to 1945 A.D)**

Paper Code; HIS-601GE (w .e. f 2020 - 21)

No. of Hours for week: 5

No. of Credits: 4

Unit – 1

Industrial Revolution: Origin, Nature and Impact. (10 Hrs)

Unit – II

Unification Movements in Italy & Germany and their Impact. (15 Hrs)

Unit – III

Communist Revolution in Russia – Causes, Course and Results – Impact on World Order.(15 Hrs)

Unit - IV

World War I: Age of Rivalry in Europe between 1870 and 1914 – Results of the War – Paris Peace Conference - League of Nations.(20 Hrs)

Unit – V

World War II: Causes, Fascism & Nazism – Results; the United Nations Organization: Structure, Functions and Challenges.(15 Hrs)

References:

- 1 J.A.Hobson, Imperialism: A Study
- 2 C.D. Hazen, Modern Europe up to 1945
- 3 H.A.L.Fisher, History of Europe
- 4 C.M.M.Ketelbey, A History of Modern Times
- 5 Grant and Temperley (ed), Europe in the 18th and 20th Centuries
- 6 David Thomson, Europe Since Napoleon
- 7 A.P.J.Taylor, The Struggle for Mastery in Europe
- 8 S.P.Nanda, History of Modern World
- 9 S.N.Dhar, International Relations and World Politics Since 1919

AG & SG SIDDHARTHA DEGREE COLLEGE OF ARTS & SCIENCE VUYURU, A.P- 521165

(An Autonomous College in the Jurisdiction of Krishna University, Machilipatnam)

III BA. Semester – VI (CBCS) Paper – VII (General Elective)

Subject; History:

Title of the Paper – History of Modern Europe (from 19th Century to 1945 A.D)

Paper Code; HIS-601GE (w .e. f 2020-21) Pass Marks: 28

Time: 3Hrs Max. Marks: 70

Model Question Paper

SECTION – A

Answer any TWO of the following

2x5=10

1. Karl Marx
2. Blood & Iron Policy
3. Lenin
4. Wilson 14 points

SECTION – B

Answer any FOURE of the following

4x15=60

5. Write an essay on Industrial Revolution and its effects
6. Describe the main stages of unification of Italy
7. Briefly explain the different stages of unification of Germany
8. Analyze the causes for 1917 Russian Revolution
9. Give a brief account of the course of First World War
10. Discuss about the causes for the failure of League of Nations
11. Estimate the rise and fall of Fascism in Italy
12. Explain about the role played by America in Second World War.

**AG & SG SIDDHARTHA DEGREE COLLEGE OF ARTS & SCIENCE VUYYURU,
A.P- 521165**

(An Autonomous College in the Jurisdiction of Krishna University, Machilipatnam)

SUBJECT- History	HIS 601GE	III B.A
------------------	-----------	---------

TITLE: History of Modern Europe (from 19th Century to 1945 A.D)

Semester – VI

Guidelines to the Paper Setter

Section	Unit – I	Unit – II	Unit – III	Unit - IV	Unit-V
A 5 Marks Questions	1	1	1	1	-
B 15 Marks Questions	1	2	1	2	2
Weightage	20	35	20	35	30

**A.G& S.G.SIDDHARTHA DEGREE COLLEGE OF ARTS &
SCIENCE**

VUYYURU-521165, KRISHNA Dt., A.P.(Autonomous)

Accredited by NAAC with "A" Grade

2021-2022



DEPARTMENT OF ECONOMICS

MINUTES OF BOARD OF STUDIES

ODD SEMESTER

29-10-2021

AGENDA

1. To Review and recommend any changes in the syllabi , Model Question Papers and Guidelines of 1st, 3rd,and 5th Semesters of I, II and III Year B.A. Economics Papers for the Academic Year 2021-2022.

- 2.To Discuss and recommend the pattern of internal Assesment , Guidelines and Model Question Papers in 1st 3rd and 5th Semesters of B.A Degree Economics papers for the Academic Year 2021-2022.

3. To Recommend the guidelines to be followed by the Question Paper Setters in Economics for the 1st, 3rd and 5th Semester-end exams.

4. To Recommend the teaching and evaluation methods to be followed under the Autonomous Status.

5. To Propose the panel of Question paper setters and Examiners.

6. To Suggest innovative methods of teaching.

- 7.Any other matter.

RESOLUTIONS:

- 1) It is Resolved to continue the same syllabi under CBC System approved by the Academic council of 2020- 2021 for 1stDegree in I Semester&III Degree in V Semester Economics papers, of B.A Classes.

The APSHE New syllabus was introduced in the I Semester of I Degree B.A from the Academic year 2020 – 2021 and in the III Semester of II Degree B.A From the Academic year 2021 – 2022.

One Value added Course is offered for 1st B.A students

- 2) Out of maximum 100 marks in each paper 30 marks shall be allocated for Internal Assessments regarding III and V Semesters.
 - A) To implement 30 marks for internal assessment and 70 marks for External Assessment from the academic year 2019-20 and that is also implemented to the III and V Semesters from 2020-21Academic year and 2021 – 2022 Academic year also.
 - B) Out of these 30 marks, 20 marks are allocated for internal tests, 5 marks are allocated for assignment for III and V Semesters. The two tests will be conducted and average of these two tests shall be deemed as the marks obtained by a student, and remaining 5 marks are allocated for attendance.

3) Out of maximum 100 marks 25 Marks shall be allocated for Internal Assessments Regarding the I Semester from the Academic year 2021 – 2022.

A) To implement 25 Marks for Internal Assessments and 75 Marks for External Assessment regarding the I Semester from the Academic year 2021 – 2022.

B) Out of these 25 marks, 20 Marks are allocated for internal tests, 5 marks are Allocated for assignment/ attendance Regarding the I Semester from the Academic year 2021 – 2022.

- 4)Discussed and recommended the syllabi, Model question papers under CBC system and guidelines to be followed by the question paper setters of 1st semester of I , III and V semesters of B.A Classes for the Academic year 2021-2022.

- 4) To follow the teaching and evaluation methods, it is also resolved to use various other methods like Group discussions, Quiz, Organizing Seminars, Guest Lectures and Workshops to upgrade the knowledge of the students and impart new skills of learning as frequently as possible.
- 5) Resolved to authorize the chairman of Board of studies to suggest the panel of paper setters and Examiners to the controller of Examinations as for the requirement.
- 7) The APSHE NewSKILL DEVELOPMENT COURSE Financial Markets is Introduced in the III Semester for II B.A Students from the Academic year 2021-2022. No Internal Examinations for this Paper. Only External Examination will be conducted for 50 Marks.

It is resolved to follow further changes if any in the syllabus by the competent Authority.

Chairman

SEMESTER-I

	Title of the Course	Instructi on Hours per week	Credit s	Evaluation		
				CIA MAR KS	SEE	
					MARK S	DURATIO N
ECO- 101	MICRO ECONOMIC ANALYSIS	5	4	25	75	3Hrs

SEMESTER-III

Cours e Code	Title of the Course	Instructi on Hours per week	Credit s	Evaluation		
				CIA MAR KS	SEE	
					MARK S	DURATIO N
ECO- 301	DEVELOPMENT ECONOMICS	5	4	30	70	3Hrs

SEMESTER-III

Course Code	Title of the Course	Instruction Hours per week	Credits	Evaluation		
				CIA MARKS	SEE	
					MARKS	DURATION
ECO-501	ECONOMIC DEVELOPMENT AND INDIAN ECONOMY	5	4	30	70	3Hrs
ECO-502	INDIAN AND ANDHRA PRADESH ECONOMY	5	4	30	70	3Hrs

PROGRAMME OUT COMES

1. able to understand basic concepts of economics.
2. able to analyze economic behavior in practice.
3. To understand the economic way of thinking.
4. ability to analyze historical and current events from an economic perspective.
5. The ability to write clearly expressing an economic point of view.
6. Be exposed to alternative approaches to economic problems through exposure of course work in allied fields.
7. To create students ability to suggest of the various economic problems.

Program me specific out comes

After completion of BA Degree program with Economics combination the Graduates will be able to

PSO1- To understand the Basics of Economics and Economic Activities of students and public in our society.

PSO2- To create an awareness on different activities like production distribution marketing etc..

PSO3- To analysis the price determination theories to the entrepreneurs, business activities.

PSO4- To prepare the students for future studies employability and responsible citizenship.



A. G & S.G. SIDDHARTHA DEGREE COLLEGE OF ARTS & SCIENCE

Vuyyuru-521165.

NAAC reaccruited at 'A' level

Autonomous -ISO 9001 – 2015 Certified

TITLE OF THE PAPER: MICRO ECONOMIC ANALYSIS

Semester: I

Course Code	ECO-101	Course Delivery Method	Class Room / Blended Mode - Both
Credits	4	CIA Marks	25
No. of Lecture Hours / Week	5	Semester End Exam Marks	75
Total Number of Lecture Hours	60	Total Marks	100
Year of Introduction:	Year of Offering: 2021 - 22	Year of Revision: ----	Percentage of Revision: 0%
CLASS:	1.B.A		

COURSE OUTCOMES:

At the end of the course, the student will be able to:

CO1-Able to understand the Definitions of Economics ,differences between micro economics and Macro Economics

CO2- Able to understand the factorsdetermining demand Law of Demand - reasons and exceptions-ElasticityofDemand and IndifferenceCurveanalysis

CO3- Able to understand the various Cost curves and Revenue Curves Concepts of Production function, Law of variable propositions , law of Return to Scale.

CO4- Able to understand the Different Markets and its Equilibrium

CO5- Able to understand the Different theories of Rent, Profit and interest .

Learning Objectives:

- 1.To understand the Definitions of Economics, differences between micro economics and Macro Economics
- 2.To understand the factorsdetermining demand Law of Demand - reasons and Exceptions-ElasticityofDemand and IndifferenceCurveanalysis
- 3.To understand the various Cost curves and Revenue Curves Concepts of Production function, Law of variable proportions , law of Return to Scale.
- 4.To understand the Different Markets and its Equilibrium
5. To understand the Different theories of Rent, Profit and Interest

**MICRO ECONOMIC ANALYSIS
SYLLABUS**

Unit-I Economic Analysis and Methodology (15HRS)

- 1.1 Definitions of Economics
 - 1.1.1 Wealth Definition (2h)
 - 1.1.2 Welfare Definition (2h)
 - 1.1.3 Scarcity Definition (2h)
 - 1.1.4 Growth Oriented Dynamic Definition- (2h)
- 1.2 Methodology in Economics
 - 1.2.1 Micro and Macro Economics- (3h)
 - 1.2.2 Deductive and Inductive Methods (3h)
 - 1.2.3 Production Possibility Curve (PPC) (1h)

Unit-II THEORY OF CONSUMPTION (23HRS)

- 2.1 Demand Analysis (2h)
 - 2.1.1 Concept & Factors Determining Demand (2h)
 - 2.1.2 Law of Demand and Exceptions (1h)
- 2.2 Elasticity of Demand (1h)
 - 2.2.1 Types of Price Elasticity of Demand (2h)
 - 2.2.2 Methods to measure Price Elasticity of Demand (2h)
- 2.3 Indifference Curve Analysis
 - 2.3.1 Indifference Schedule & Indifference map (2h)
 - 2.3.2 Marginal Rate of Substitution (2h)
 - 2.3.3 Properties of Indifference curves (2h)
 - 2.3.4 Budget line & Consumers Equilibrium through Indifference Curve (5h)
 - 2.3.5 Consumer's Surplus through Indifference Curve Analysis (2h)

Unit-III THEORY OF PRODUCTION (20HRS)

- 3.1 Concept of Production Function (1h)
 - 3.1.1 Cobb-Douglas Production Function (1h)
 - 3.1.2 The law of variable proportions (2h)
 - 3.1.3 The law of Returns to Scale (2h)
 - 3.1.4 Economies of large Scale Production (2h)
- 3.2 Concepts of cost (1h)
 - 3.2.1 Short run Cost Curves (3hrs)
- 3.3 Law of supply (1hr)
- 3.4 Revenue Concepts (T.R., A.R. & M.R.) (3hrs)
 - 3.4.1 Relationship between AR, MR & E.D (2hrs)
 - 3.4.2 Cost minimization (1h)
 - 3.4.3 Profit Maximization (1h)

Unit-IV THEORY OF EXCHANGE (12HRS)

- 4.1 Classification of Markets (1h)
- 4.2 Features of Perfect Market Conditions (2h)

- 4.3 Price Determination under Perfect Competition Market (2hrs)
- 4.4 Features of Monopoly Market (2h)
- 4.5 Features of Monopolistic Competition Market (2h)
- 4.6 Features of Oligopoly Market (2h)
- 4.7 Kinky Demand Curve Analysis (2hrs)

Unit-V THEORY OF DISTRIBUTION

(20HRS)

- 5.1 Concepts of Functional and Personal Distribution (2h)
- 5.2 Marginal Productivity Theory of Distribution (2h)
- 5.3 Theories of Rent
 - 5.3.1 Ricardian Theory of Rent (1hr)
 - 5.3.2 Marshall's Economic rent (2h)
- 5.4 Theories of Wage
 - 5.4.1 Standard of Living Theory of wages (1h)
 - 5.4.2 Modern Theory of wages (2h)
- 5.5 Theories of Interest
 - 5.5.1 Classical Theory of Interest (2h)
 - 5.5.2 Loanable Funds Theory of Interest (2h)
 - 5.5.3 Keynes Liquidity Preference Theory of Interest (2h)
- 5.6 Theories of Profit
 - 5.6.1 Risk Theory of Profit (1h)
 - 5.6.2 Uncertainty Theory of Profit (1h)
 - 5.6.3 Dynamic Theory of Profit (1h)
 - 5.6.4 Innovation Theory of Profit (1h)

Text Book : Telugu Academy Publications

Reference Books :

H.L. Ahuja – Advanced Economic Theory - S.Chand & Company Publishers
 H.S. Agarwal – Principles of Economics
 M.L. Seth – Micro Economics, Lakshmi Narayana Agarwal Publishers
 A.W. Stonier & D.C Hague – A Text Book of Economic Theory, E.L.B.S
 Koutsoyiannis : Modern Micro Economics, Mc. Millan

Co-curricular activities and Assessment Methods:

1. Continuous Evaluation: Monitoring the progress of student's learning
2. Class Tests, Assignments and Quizzes
3. Presentations, Projects and Assignments and Group Discussions: Enhances critical thinking skills and personality
4. Semester- end Examination: critical indicator of student's learning and teaching methods adopted by teachers throughout the semester

A.G. & S.G.SIDDHARTHA DEGREE COLLEGE OF ARTS & SCIENCE
(AUTONOMOUS), (2021 - 2022) VUYYURU

SEMESTER- I

MODEL PAPER

Section-A

I. Answer any Five of the Following:

5X5=25M

1. Dynamic Theory Profit- L2,CO5
2. Classification of Markets- L2,CO4
3. Relationship between Average Cost and Marginal Cost-L3,CO3
4. Features of Monopoly Market- L1,CO4
5. Subsistence theory of Wages-L2,CO5
6. Explain the law of supply-L3,CO3
7. Explain the concept of Economic Rent?- L3,CO5
8. Explain Micro Economic analysis -L3,CO1

Section-B

Answer of the Following:

5X10=50M

- 9.(A) Discuss the Concept of Risk bearing theory of Profits ?-L3,CO5
(or)
B) Critically examine the Keynes Liquidity Preference theory of interest- L3,CO5
10. (A) Define Micro and Macro Economics. Explain their Importance-L1,CO1
(or)
(B) Examine the Modern theory of wages ?-L3,CO5
11. (A) Critically examine the Marginal Productivity theory of distribution?-L3,CO5
(or)
(B) Graphically explain the law of variable proportions-L3, CO3
12. (A) Explain the Price determination of under Perfect Competition?- L3,CO4
(or)
(B) Examine the Scarcity definition -L2,CO1
13. (A) Explain consumer equilibrium with the help of indifference curve analysis-
L3,CO2
(or)
(B) Analyse the features of Oligopoly market and write about Kinky Demand
Curve ?-L1,CO4



A. G & S.G. SIDDHARTHA DEGREE COLLEGE OF ARTS & SCIENCE

Vuyyuru-521165.

NAAC recredited at 'A' level

Autonomous -ISO 9001 – 2015 Certified

TITLE OF THE PAPER:DEVELOPMENT ECONOMICS

Semester: III

Course Code	ECO-301	Course Delivery Method	Class Room / Blended Mode - Both
Credits	4	CIA Marks	25
No. of Lecture Hours / Week	5	Semester End Exam Marks	75
Total Number of Lecture Hours	60	Total Marks	100
Year of Introduction:	Year of Offering: 2021 - 22	Year of Revision: ----	Percentage of Revision: 0%
CLASS:	II.B.A		

LEARNING OUTCOMES FOR THE COURSE :

At the end of the course, the student is expected to demonstrate the following cognitive abilities and psychomotor skills.

1.Remembers and states in a systematic way (Knowledge)

Various concepts and definitions and indicators relating to economic growth and Development including recent developments

2. Explains (understanding)

a. Distinction between growth and development with examples

c. Characteristics of developing and developing economies and distinction between the two

d. factors contributing to development, Choice of Techniques and a few important models and strategies of growth

3. Critically examines using data and figures (analysis and evaluation)

a. the theoretical aspects of a few models and strategies of economic growth

b. role and importance of various financial and other institutions in the context of India's economic development

4. Draws critical diagrams and graphs.

a. to explain the models and strategies

b. to highlight empirical evidences to support the strategies

DEVELOPMENT ECONOMICS

Syllabus

Module - 1: Economic Growth and Development

Economic Development as a Branch of Study of Economics – Scope and Importance - Distinction between Economic Growth and Economic Development -Measures of Economic Development and their limitations - Relevance of Herd (Group) Immunity in the context of COVID 19 - three core values of economic development : Sustainability, Self-esteem and Freedom – Economy and Environment : Concepts of sustainable development and inclusive growth

Module -2: Modern Economic Growth

Characteristics of Underdeveloped Countries - World Bank and IMF Classification of countries - Modern economic growth – Kuznets’ Six Characteristics -Obstacles to economic development - Vicious Circle of Poverty and cumulative causation -Factors of economic growth: Economic and Non-economic - Capital Formation – Foreign and Domestic capital, Debt and Disinvestment.

Module-3: Theories of Development and Underdevelopment

Classical Theory: Adam Smith, Ricardo and Malthus -Marxian Theory - Schumpeter Theory - Rostow’s Stages of Economic Growth -Harrod-Domar two sector model -Solow’s Model and Robinson’s Golden Age

Module – 4: Strategies of Economic Development

Strategies of Economic Development – Big Push -Balanced Growth -Unbalanced Growth - Mahalanobis Model - Agriculture vs Industry -Capital Intensive Technology vs Labour Intensive Technology -Role of Infrastructure in Economic Development

Module - 5: Institutions and Economic Development

Role of State in Economic Development -Role of Markets - Market Failure and Regulation by State -Public sector vs Private sector -Economic Planning – concept, objectives and types - NITIAYog - Economic Federalism -Financial Institutions and Economic Development – Role of International Institutions – IDBI, ADB, IMF – Foreign Trade – FIIs and FDIs

Reference Books:

1. Dhingra, I.C., Indian Economy, Sultan Chand, New Delhi, 2014.
2. Gaurav Datt and Ashwani Mahajan, Datt and Sundharam's Indian Economy, S.Chand & Co., 2016.
3. G. M. Meier, Leading Issues in Economic Development, Oxford University Press, New York, 3/e.
4. M. P. Todaro and Stephen C. Smith, Economic Development, 10/e, Indian Edition Published by Dorling Kindersley India Pvt. Ltd. 2012.
5. M. L. Koncham, Economic development and planning, Himalaya publications
6. S.K.Misra & V.K.Puri, Indian Economy, Himalaya Publishing House, 2015.
7. R.S.Rao, V.Hanumantha Rao & N.Venu Gopal (Ed.), Fifty Years of Andhra Pradesh (1956-2006), Centre for Documentation, Research and Communications, Hyderabad, 2007.
8. G. Omkarnath, Economics - A Primer for India - Orient Blackswan, 2012.
9. Economic development and growth, Spectrum Publishing House, Hyderabad, 2016

Recommended Co-curricular Activities:

1. Assignments on the models and the strategies of economic development adopted in Indian economy
2. Student Seminar on development oriented themes relating to Indian economy
3. Quiz to test critical understanding of the fundamental concepts of growth and development and the growth models and strategies
4. Group discussion on the effectiveness of the roles played by various institutions in India's economic development
5. Group project work to examine specific aspects of growth like poverty, unemployment, human development, gender development as Indian experience in the context of economic development preferably at the state and local level
6. Poster presentation

**A.G. & S.G.SIDDHARTHA DEGREE COLLEGE OF ARTS & SCIENCE
(AUTONOMOUS), (2021 - 2022) VUYYURU**

SEMESTER – III	COURSE CODE:ECO - 301
PAPER TITLE :DEVELOPMENT ECONOMICS	

Duration : 3Hours

Maximum marks : 70

Pass marks : 28

SECTION - A

Answer any **TWO** of the following questions

(2x5=10 Marks)

1. Features of Economic Development.
2. World Bank's country classification systems.
3. Labour Intensive Technology.
4. What are the different types of Plans.

SECTION – B

Answer any **FOUR** of the following questions.

(4X15=60 Marks)

5. What is Economic Growth and What is Economic Development? Differentiate between Economic Growth and Economic Development.
6. Write about the Relevance of Herd (Group) Immunity in the context of Covid – 19.
7. Explain the features of Developing Countries with special reference to India.
8. Write about the vicious circle of poverty.
9. Explain about Schumpeter's Theory of Economic Development.
10. Write about the Role of Infrastructure in Economic Development.
11. What are the main objectives of planning in India?
12. Write about NITI AYOJ?

**A.G. & S.G.SIDDHARTHA DEGREE COLLEGE OF ARTS & SCIENCE
(AUTONOMOUS), (2021 - 2022) VUYYURU**

The Guidelines to be followed by the question paper setters in **DEVELOPMENT ECONOMICS** for the III Semester – End Examinations (2021 - 2022)

PAPER TITLE : DEVELOPMENT ECONOMICS

Paper- III Semester – III Maximum marks : 70 Duration : 3Hours

Weightage for the question paper

Syllabus	Section-A (Short answer questions)	Section-B (Essay questions)
Unit-1 (35Marks)	1	2
Unit-2 (35Marks)	1	2
Unit-3 (15Marks)	-----	1
Unit-4 (20Marks)	1	1
Unit-5 (35Marks)	1	2
TOTAL 140	20	120

1. Each question carries 5 marks in Section-A
2. Each Essay question carries 15 marks in Section –B
3. The Question papers setters are requested to cover all the topics in the syllabus stipulated as per the weightage given by us.



A. G & S.G. SIDDHARTHA DEGREE COLLEGE OF ARTS & SCIENCE

Vuyyuru-521165.

NAAC reaccredited at 'A' level

Autonomous -ISO 9001 – 2015 Certified

**TITLE OF THE PAPER: ECONOMIC DEVELOPMENT AND INDIAN ECONOMY Semester:
V**

Course Code	ECO-501	Course Delivery Method	Class Room / Blended Mode - Both
Credits	4	CIA Marks	25
No. of Lecture Hours / Week	5	Semester End Exam Marks	75
Total Number of Lecture Hours	60	Total Marks	100
Year of Introduction:	Year of Offering: 2021 - 22	Year of Revision: ----	Percentage of Revision: 0%
CLASS:	III.B.A		

LEARNING OUTCOMES FOR THE COURSE

- 1.To able to understand economic growth and development and different growth models .HorrodDomor, Adamsmithrestov theory etc Karal Marks able to understand some growth models
- 2.Development theories: theories of persistence of under development –stratagies for development balanced and unbalanced growth strategy ,development with unlimited supply of labour (lewis).
- 3.Economics of natural resourses and sustainable development :- this course will help in understanding that types of natural resourses and their exploitation
- 4.Understand the population and economic growth understand basic futures of Indian economy .trand and composition of national income and for capital income ,occupational distribution ,basic demography futures.
5. Study poverty , inequality and unemployment ; concuptuan and measurement issues –the Indian situation.to analyze new economic policies (privatization liberalization and globalization in india.

ECONOMIC DEVELOPMENT AND INDIAN ECONOMY SYLLABUS

Module - 1

Concept of Economic Growth - Distinction between economic growth and development - Measurement of economic development -Theories of Economic Growth:

Adam Smith, Rostow, Karl Marx and Harrod&Domar Models.

Module - 2

Sustainable development - Balanced and unbalanced growth-choice of techniques
Labour intensive and capital intensive methods.

Module - 3

Basic features of the Indian Economy - Natural Resources - Important
Demographic features- Concept of Population Dividend - Population Policy.

Module - 4

National Income in India - trends and composition-poverty, inequalities and
Unemployment - Measures taken by the Government. - MGNREGS

Module - 5

Economic reforms - liberalization, privatization and globalisation - concept of
inclusive growth.

REFERENCES:

1. Dhingra, I.C - "Indian Economy", Sultan Chand, 2014.
2. RuddarDutt and K.P.M. Sundaram - "Indian Economy", S.Chand& Co., 2015.
3. G.M.Meier -"Leading Issues in Economic Development", Oxford University Press, New York,.
4. M.P.Todaro - "Economic Development", Longman, London 6/e, 1996.
5. Reserve Bank of India - Hand book of Statistics on Indian Economy (Latest).
6. S.K.Misra&V,K,Puri - "Indian Economy", Himalaya Publishing House, 2015.
7. R.S.Rao, V.HanumanthaRao&N.VenuGopal (Ed) - Fifty Years of Andhra Pradesh (1956-2006), Centre for Documentation, Research and Communications, Hyderabad, 2007.
8. G.Omkarnath - Economics - A Primer for India - Orient Blackswan, 2012.
9. Benjamin Higgins - Economic Development
10. Telugu Academy Publications.
11. Dr. Ch.S.G.K. Murthy, Indian Economy - Gitam University

**A.G. & S.G.SIDDHARTHA DEGREE COLLEGE OF ARTS & SCIENCE
(AUTONOMOUS), (2021 - 2022) VUYYURU**

SEMESTER – V	COURSE CODE:ECO-501
PAPER TITLE : ECONOMIC DEVELOPMENT AND INDIAN ECONOMY	

Duration : 3Hours

Maximum marks : 70

Pass marks : 28

SECTION - A

Answer any **TWO** of the following questions

(2x5=10 Marks)

1. Labour intensive techniques
2. Population Dividend
3. Poverty.
4. Globalisation.

SECTION – B

Answer any **FOUR** of the following questions

(4X15=60 Marks)

5. Critically Examine the Recordian theory of Growth.
6. Explain the concepts of Economic Growth and Economic Development and its differences
7. Critically Examine the Balanced Growth theory.
8. What are the Basic features of Indian Economy.
9. Explain the causes of population explosion in India.
10. Explain the composition and trends in India's National Income.
11. What is poverty? Mention the measures taken by the Government.
12. Explain the Liberalisation policy in India.

**A.G. & S.G.SIDDHARTHA DEGREE COLLEGE OF ARTS & SCIENCE
(AUTONOMOUS), (2021 - 2022) VUYYURU**

The Guidelines to be followed by the question paper setters in **ECONOMIC DEVELOPMENT AND INDIAN ECONOMY** for the V Semester – End Examinations (2020 - 2021)

PAPER TITLE :ECONOMIC DEVELOPMENT AND INDIAN ECONOMY

Paper- V Semester – V Maximum marks : 70 Duration : 3Hours

Weightage for the question paper

Syllabus	Section-A (Short answer questions)	Section-B (Essay questions)
Unit-1 (30Marks)	-----	2
Unit-2 (20Marks)	1	1
Unit-3 (35Marks)	1	2
Unit-4 (35Marks)	1	2
Unit-5 (20Marks)	1	1
TOTAL 140	20	120

1.Each question carries 5 marks in Section-A

2.Each Essay question carries 15 marks in Section –B

3. The Question papers setters are requested to cover all the topics in the syllabus stipulated as per the weightage given by us.



A. G & S.G. SIDDHARTHA DEGREE COLLEGE OF ARTS & SCIENCE

Vuyyuru-521165.

NAAC reaccredited at 'A' level

Autonomous -ISO 9001 – 2015 Certified

TITLE OF THE PAPER:INDIAN AND ANDHRAPRADESH ECONOMY

Semester: V

Course Code	ECO-501	Course Delivery Method	Class Room / Blended Mode - Both
Credits	4	CIA Marks	25
No. of Lecture Hours / Week	5	Semester End Exam Marks	75
Total Number of Lecture Hours	60	Total Marks	100
Year of Introduction:	Year of Offering: 2021 - 22	Year of Revision: ----	Percentage of Revision: 0%
CLASS:	III.B.A		

LEARNING OUTCOMES FOR THE COURSE:

- 1.Upon successful completion of this course , students should have to acquire knowledge regarding agriculture sector in India ,its trends and productivity
- 2.to make the students to understand about Indian industry.
- 3.to understand foreign direct investment and service sector in India they will be identifying the various objectives of pharming in india and its achievements.
- 4.To make students to understand about Andhra Pradesh economy and its progress

Indian and Andhra Pradesh Economy

Syllabus

Module - 1

Indian Agriculture - Importance of Agriculture in India - Agrarian structure and relations- Factors determining Productivity- Agricultural Infrastructure - Rural credit - Micro Finance - Self Help Groups (SHGs) - Agricultural Price policy- concept of Crop Insurance - Food Security.

Module - 2

Structure and growth of Indian Industry - Industrial policies of 1956 & 1991 Meaning of Micro small and Medium Enterprises (MSMEs)- Problems and Prospects of small scale Industries in India.

Module - 3

Disinvestment in India - FEMA - Foreign direct investment - Services Sector in India – Reforms in Banking and Insurance -, IT, Education and Health.

Module - 4

Planning in India Economy - Objectives of Five year plans - Review of Five year Plans - Current Five year plan- NITI Aayog

Module - 5

Andhra Pradesh Economy - Population - GSDP - Sector Contribution and trends - IT – Small Scale Industry - SEZs.

REFERENCES:

1. Dhingra, I.C - "Indian Economy", Sultan Chand, 2014.
2. RuddarDutt and K.P.M. Sundaram - "Indian Economy", S.Chand& Co., 2015.
3. G.M.Meier - "Leading Issues in Economic Development", Oxford University Press, New York, 3/e.
4. M.P.Todaro - "Economic Development", Longman, London 6/e, 1996.
5. Reserve Bank of India - Hand book of Statistics on Indian Economy (Latest).
6. S.K.Misra&V,K,Puri - "Indian Economy", Himalaya Publishing House, 2015.
7. R.S.Rao, V.HanumanthaRao&N.VenuGopal (Ed) - Fifty Years of Andhra Pradesh (1956-2006), Centre for Documentation, Research and Communications,Hyderabad, 2007.
8. G.Omkarnath - Economics - A Primer for India - Orient Blackswan, 2012.
9. Telugu Academy Publications.
10. Dr.Ch.S.G.K.Murthy, Indian Economy - Gitam University.

A.G. & S.G.SIDDHARTHA DEGREE COLLEGE OF ARTS & SCIENCE
(AUTONOMOUS), (2021 - 2022) VUYYURU

SEMESTER – V	COURSE CODE:ECO-502
PAPER TITLE : Indian and Andhra Pradesh Economy	

Duration : 3Hours

Maximum marks : 70

Pass marks : 28

SECTION - A

Answer any **TWO** of the following questions

(2x5=10 Marks)

1. Industrial policy 1956.
2. FEMA
3. NeethiAyog .
4. SEZs (Special Economic Zones).

SECTION – B

Answer any **FOUR** of the following questions

(4X15=60 Marks)

5. Explain the Importance of Agriculture sector in India.
6. What is Green Revolution ? Explain the causes and Benefits of Green Revolution.
7. State the 1991 Industrial Resolution policy.
8. Explain the problems and remedies of small and cottage Industries in India.
9. Review the Disinvestment in India.
10. Explain the Foreign Direct Investment in India .
11. Review the performance of Five year plan's in India.
12. Explain the changes in the shares of various sectors in Gross Domestic Product in Andhrapradesh State.

A.G. & S.G.SIDDHARTHA DEGREE COLLEGE OF ARTS & SCIENCE
(AUTONOMOUS), (2021 - 2022) VUYYURU

The Guidelines to be followed by the question paper setters in **Indian and Andhra Pradesh Economy** for the V Semester – End Examinations (2020 - 2021)

PAPER TITLE : Indian and Andhra Pradesh Economy

Paper- V Semester – V Maximum marks : 70 Duration : 3Hours

Weightage for the question paper

Syllabus	Section-A (Short answer questions)	Section-B (Essay questions)
Unit-1 (30Marks)	-----	2
Unit-2 (35Marks)	1	2
Unit-3 (35Marks)	1	2
Unit-4 (20Marks)	1	1
Unit-5 (20Marks)	1	1

Total 140

20

120

- 1.Each question carries 5 marks in Section-A
- 2.Each Essay question carries 15 marks in Section –B
3. The Question papers setters are requested to cover all the topics in the syllabus stipulated as per the weightage given by us



A. G & S.G. SIDDHARTHA DEGREE COLLEGE OF ARTS & SCIENCE

Vuyyuru-521165.

NAAC reaccredited at 'A' level

Autonomous -ISO 9001 – 2015 Certified

TITLE OF THE PAPER:FINANCIAL MARKETS

Semester: V

Course Code	FM-301	Course Delivery Method	Class Room / Blended Mode - Both
Credits	2	CIA Marks	25
No. of Lecture Hours / Week	2	Semester End Exam Marks	75
Total Number of Lecture Hours	30	Total Marks	100
Year of Introduction:	Year of Offering: 2021 - 22	Year of Revision: ----	Percentage of Revision: 0%
CLASS:	III.B.A		

Learning Outcomes:

After successful completion of this course, the students will be able to;

1. Acquire knowledge of financial terms
2. Know the concepts relating to and markets and different avenues of investment
3. Understand the career skills related to Stock Exchanges
4. Comprehend the personal financial planning and money market skills

SKILL DEVELOPMENT COURSES
ARTS STREAM
Syllabus of
FINANCIAL MARKETS

UNIT-I: 06hrs

Indian Financial System- its components - Financial markets and institutions

UNIT-II: 10hrs

Capital Market - its function - organizations - elements - (shares, debentures, bonds, mutual funds) debt market - Equity market (SEBI) and secondary market (NSE)

UNIT-III: 10hrs

Money market - Organized - Unorganized - Sub market (call money, commercial bills, Treasury bill, Certificate of Deposit, Commercial papers)

Co-curricular activities: (04 hrs)

1. Collection and study of pamphlets, application forms etc.
2. Invited lectures on the field topics by local experts
3. Introducing Online classes from NSE
4. Field visit to mutual fund offices/share brokers
5. Observation, study and analysis of selected companies share prices
6. Assignments, Group discussion, quiz etc.

Reference books:

1. T.R. Jain R.L.Sarma - Indian Financial System- VK Global publisher
2. Jithendra Gala - Guide to Indian Stock markets Buzzing Stock publishing house
3. Saha Siddhartha- Indian financial System- and Markets - McGraw hill
4. Websites on Indian Financial markets.

A.G. & S.G.SIDDHARTHA DEGREE COLLEGE OF ARTS & SCIENCE
(AUTONOMOUS), (2021 - 2022) VUYYURU

MODEL QUESTION PAPER FORMAT

Max. Marks: 50

Time: 1 1/2hrs (90 Minutes)

SECTION A (Total: 4x5=20 Marks)

(Answer any four questions. Each answer carries 5 marks)

1. Objectives of financial system.
2. Functions of financial markets.
3. Difference between primary and secondary Market.
4. Differences between Debt market and Equity market.
5. Methods of floatation of securities in primary market.
6. Commercial bill market.
7. Role of RBI in the commercial paper market.
8. Types of bills in money market.

SECTION B (Total: 3x10 = 30 Marks)

(Answer any three questions. Each answer carries 10 marks)

1. Explain the classification of financial markets.
2. Describe the Role of financial system in Economic Development.
3. Define capital Market? Explain its characteristics?
4. Write about National Stock Exchange of India limited (NSE).
5. Define Money Market? Explain the characteristics, objectives and functions of money market.
6. Explain the challenges of Indian money market and describe measures to improve Indian money market.

A.G. & S.G.SIDDHARTHA DEGREE COLLEGE OF ARTS & SCIENCE
(AUTONOMOUS), (2021 - 2022) VUYYURU

The Guidelines to be followed by the question paper setters in FINANCIAL
MARKETS for the III Semester – End Examinations (2021 - 2022)

PAPER TITLE :FINANCIAL MARKETS

Paper- S.D.C Semester – III

Maximum marks : 50

Duration : 1 1/2Hours

Weightage for the question paper

Syllabus	Section-A (Short answer questions)	Section-B (Essay questions)
Unit-1 (30Marks)	2	2
Unit-2 (35Marks)	3	2
Unit-3 (35Marks)	3	2
Total 100	40	60

- 1.Each question carries 5 marks in Section-A
- 2.Each Essay question carries 10 marks in Section –B
3. The Question papers setters are requested to cover all the topics in the syllabus stipulated as per the weightage given by us

**A.G& S.G.SIDDHARTHA DEGREE COLLEGE OF ARTS &
SCIENCE**

VUYYURU-521165, KRISHNA Dt., A.P.(Autonomous)

Accredited by NAAC with "A" Grade

2021-2022



DEPARTMENT OF ECONOMICS

MINUTES OF BOARD OF STUDIES

EVEN SEMESTER

06-04-2022

AG&SG SIDDHARTHA DEGREE COLLEGE OF ARTS and SCIENCE
(AUTONOMOUS) VUYYURU

ACEDAMIC YEAR - 2021 - 2022

Minutes of the meeting of the Board of Studies in Economics of AG & SG Siddhartha Degree College of Arts & Science, Vuyyuru, held at 10.30 a.m on 06 – 04 – 2022 In the Department of Economics Through online Mode.

Sri.N.RamaRaol, HOD, Economics has Presided over the BOS meeting

Members Present:

- 1) N. Rama Rao Chairman Head, Department of Economics
(Sri.N.RamaRao) AG & SG S Degree College of Arts & Science
Vuyyuru-521165
- 2) G. Nirmala Jyothi University Head Department of Economics
(MrsG.NirmalaJyothi) Nominee S.A.S. Government Degree College
NarayanaPuram
- 3) D. Aruna Academic Council Head, Department of Economics
(D.Aruna) Nominee SDMS MahilaKalasala, Vijayawada
- 4) G. Suresh Babu Academic Council Lecturer in Economics ,
(G.SureshBabu) Nominee V.S.R. Government Degree College,

Movva

AGENDA

1. To Review and recommend any changes in the syllabi , Model Question Papers and Guidelines of 2nd, 4th and 6th Semesters of I, II and III Year B.A Economics Papers for the Academic Year 2021-2022.
2. To Discuss and recommend the pattern of internal Assessment , Guidelines and Model Question Papers in 2nd, 4th and 6th Semesters of B.A Degree Economics papers for the Academic Year 2021-2022.
3. To Recommend the guidelines to be followed by the Question Paper Setters in Economics for the 2nd, 4th and 6th Semester-end exams.
4. To Recommend the teaching and evaluation methods to be followed under the Autonomous Status.
5. To Propose the panel of Question paper setters and Examiners.
7. Any other matter.

RESOLUTIONS:

- 1) It is resolved to continue the same syllabi under CBC System approved by the Academic council of 2020- 2021 for I and III B,A Papers in the II and VI Semester of I and III B.A classes.

The APSHE was introduced Two New Subjects and New syllabus in the IV Semester of II Degree B.A from the Academic year 2021 – 2022.

- 2) Out of maximum 100 marks in each paper 30 marks shall be allocated for Internal Assessments regarding IV and VI Semesters.
 - A) To implement 30 marks for internal assessment and 70 marks for External Assessment from the academic year 2019-20 and that is also implemented to the IV and VI Semesters from 2020-21 Academic year and 2021 – 2022 Academic year also.
 - B) Out of these 30 marks, 20 marks are allocated for internal tests, 5 marks are allocated for assignment for IV and VI Semesters. The two tests will be conducted and average of these two tests shall be deemed as the marks obtained by a student, and remaining 5 marks are allocated for attendance.
 - C) Out of maximum 100 marks 25 Marks shall be allocated for Internal Assessments regarding the II Semester from the Academic year 2021 – 2022.**
 - D) To implement 25 Marks for Internal Assessments and 75 Marks for External Assessment regarding the II Semester from the Academic year 2021 – 2022.**
 - E) Out of these 25 marks, 20 Marks are allocated for internal tests, 5 marks are Allocated for assignment/ attendance Regarding the II Semester from the Academic year 2021 – 2022.**
- 3) Discussed and recommended the syllabi, Model question papers under CBC system and guidelines to be followed by the question paper setters of II,IV and VI semesters of B.A Classes for the Academic year 2021-2022.
- 4) To follow the teaching and evaluation methods, it is also resolved to use various other methods like Group discussions, Quiz, Organizing Seminars, Guest Lectures and Workshops to upgrade the knowledge of the students and impart new skills of learning as frequently as possible.

- 5) Resolved to authorize the chairman of Board of studies to suggest the panel of paper setters and Examiners to the controller of Examinations as for the requirement.
- 6) **The APSHE was introduced Two New Subjects i.e Economic Development in India and ANDHRA PRADESH and Statistical Methods for Economics in the IV Semester of II Degree B.A from the Academic year 2021 – 2022. It is resolved to Follow the APSCHE New syllabus in the IV Semester of II Degree B.A from the Academic year 2021 – 2022.**

It is resolved to follow further changes if any in the syllabus by the competent Authority.

Chairman

SEMESTER -II

Course Code	Title of the Course	Instruction Hours per week	Credits	Evaluation		
				CIA MARKS	SEE	
		MARKS			DURATION	
ECOT 21B	MACROECONOMIC ANALYSIS	5	4	25	75	3 Hrs.

SEMESTER –IV

Course Code	Title of the Course	Instruction Hours per week	Credits	Evaluation		
				CIA MARKS	SEE	
		MARKS			DURATION	
ECO – 401C	ECONOMIC DEVELOPMENT-INDIA AND ANDHRA PRADESH	5	4	25	75	3 Hrs.
ECO – 402C	STATISTICAL METHODS FOR ECONOMICS	5	4	25	75	3 Hrs.

SEMESTER -VI

Course Code	Title of the Course	Instruction Hours per week	Credits	Evaluation		
				CIA MARKS	SEE	
					MARKS	DURATION
ECO – 601GE	AGRICUTURAL ECONOMICS	5	4	25	75	3 Hrs.
ECO – 602CE	Agribusiness Environment in Andhra Pradesh	5	4	25	75	3 Hrs.
ECO – 603CE	AGRICULTURAL OUTPUT MARKETING	5	4	25	75	3 Hrs.
ECO – 604	PROJECT WORK	-	-	-	-	-

AG&SG SIDDHARTHA DEGREE COLLEGE OF ARTS and SCIENCE
(AUTONOMOUS) VUYYURU
ACEDAMIC YEAR 2021 - 2022

(An Autonomous college in the jurisdiction of Krishna University, Machilipatnam)

Economics	ECOT21B	2021-2022	B.A.(E.M)
-----------	---------	-----------	-----------

MACROECONOMIC ANALYSIS

B.A SEMESTER-II

UNIT – I INTRODUCTION AND NATIONAL INCOME

1.1 AN INTRODUCTION TO MACRO ECONOMICS

- 1.1.1 Definition, scope and importance of Macro Economics
- 1.1.2 Evolution of Macro Economics
- 1.1.3 Macro Economics Paradoxes
- 1.1.4 Circular Flow of Income and Expenditure in Two, Three and Four sector Economy

1.2 NATIONAL INCOME

- 1.2.1 Meaning and definition of National Income – Marshall, Pigou, Fisher
- 1.2.2 National Income Aggregates – GDP, GNP, NDP, NNP, NNP_{fc}, PI, DI, P.CI, RNI, RPIC
- 1.2.3 Measurement of National Income – Product, Income and Expenditure methods
- 1.2.4 Concepts of Green Accounting

UNIT – II THEORIES OF EMPLOYMENT

2.1 THEORIES OF EMPLOYMENT

- 2.1.1 Classical Theory of Employment
- 2.1.2 Say's Law of Markets
- 2.1.3 Keynesian Theory of Employment

2.2 THEORIES OF CONSUMPTION

- 2.2.1 Average and Marginal propensity to consume
- 2.2.2 Keynes psychological Law of Consumption
- 2.2.3 Brief review of Absolute, Relative, Lifecycle and Permanent income hypothesis

2.3 THEORIES OF INVESTMENT

- 2.3.1 Marginal Efficiency of Capital (MEC)
- 2.3.2 Multiplier Principle Concepts and its Working
- 2.3.3 The Acceleration principle

2.4 Aggregate Demand Function – Algebraic Explanation

2.5 IS – LM Curves – Equations

2.6 The Goods Market and Money Market Equilibrium – Algebraic Explanation

UNIT III MONEY AND BANKING

3.1 THEORY OF MONEY

- 3.1.1 Meaning, Definition and Function of Money
- 3.1.2 Gresham's Law
- 3.1.3 R.B.I Classification of Money (M₁, M₂,
- 3.1.4 Fisher's Quantity Theory of Money
- 3.1.5 Cambridge Approach (Marshall, Pigou, Robertson and Keynes Equations)

3.2 THEORY OF BANKING

- 3.2.1 Definition and Types of Banking
- 3.2.2 Functions of Commercial Banks
- 3.2.3 Functions of Central Bank
- 3.2.4 Credit Control by Central Bank
- 3.2.5 Factors Contributing to the Growth of NBFC's

UNIT IV INFLATION AND TRADE CYCLES

4.1 THEORY OF INFLATION

- 4.1.1 Meaning, Definition and Concepts of Inflation
- 4.1.2 Demand Pull and Cost-Push Inflation
- 4.1.3 Philip's Curve Hypothesis
- 4.1.4 Measurements of Inflation - C.P.I and W.P.I
- 4.1.5 Causes and Effects of Inflation

4.2 THEORY OF TRADE CYCLES

- 4.2.1 Trade Cycles Meaning and Definition
- 4.2.2 Phases of Trade Cycles
- 4.2.3 Causes of Trade Cycles
- 4.2.4 Measures to Control Trade Cycles

UNIT – V FINANCE AND INSURANCE

5.1 THEORY OF FINANCE

- 5.1.1 Financial Assets and Financial Intermediates
- 5.1.2 Structure of Financial System
- 5.1.3 Functions of Money Market
- 5.1.4 Functions of Capital Market
- 5.1.5 Functions of Stock Exchange
- 5.1.6 Bombay Stock Exchange (BSE) and National Stock Exchange (NSE)

5.2 THE THEORY OF INSURANCE

5.2.1 Concept and Origin of Insurance

5.2.2 Types of Insurance

5.2.3 Importance of Insurance

Text book:

Macro Economics – Telugu Akademi Publication

Reference Books:

1. Dillard D. The Economics of Jhon Maynard Keynes, Cross by Lock Wood and sons London
2. M. C. Vaish – Macroeconomics Theory, Vikas Publishing House, New Delhi
3. S.B Gupta – Monetary Economics, S. Chanda and Co, Delhi
4. P.N Chopra – Macroeconomics, Kalyani Publishers, Ludhiana 2014
5. D.M Mithani, Macro Economics Analysis and Policy, Oxford and IBH, New Delhi
6. MN Mishra and SB Mishra, Insurance Principles and Practice, S Chand
7. Lewis, M K and P D Mizan – Monetary Economics, Oxford University Press, New Delhi
8. Central Statistical Organisation, National Accounts Statistics
9. M.L. Seth, Macroeconomics, Lakshmi Narayan Agarwal, 2006
10. K.P.M. Sundaram, Money, Banking and International Trade, Sultan Chand, 2006
11. R.R. Paul, Monetary Economics, Kalyani Publishers, Ludhiana, 2018
12. Macroeconomics, Spectrum Publishing House, Hyderabad, 2016

Recommended Co-curricular Activities:

1. Assignments on trends in national income, money supply and inflation
2. Student Seminars/webinar on macroeconomic themes of contemporary importance for Indian economy (Eg-Covid-19 impact on aggregated demand, supply chain disruption, policy response etc)
3. Quiz to test critical understanding of the concepts and theories of macroeconomics and their application in practice
4. Group discussion on monetary policy and its effectiveness with reference to recent developments.
5. Group project work to study the trends in national income, inflation, money, supply etc.
6. Chat/poster presentation on National Income Trends, inflation, aggregated demand etc.
7. Web-based assignment on Banking/Money.

AG&SG SIDDHARTHA DEGREE COLLEGE OF ARTS and SCIENCE
(AUTONOMOUS) VUYYURU
ACEDAMIC YEAR 2021 - 2022

(An Autonomous college in the jurisdiction of Krishna University, Machilipatnam)

SEMESTER- II

Model Paper
SECTION-A

Answer any Five of the Following:

5X5=25m

1. Product method.
2. J.B. Say market law
3. Investment function.
4. Types of inflation.
5. Gresmam's Law.
6. R.B.J. classification of money
7. Cambridge equation.
8. Per capita income

SECTION-B

Answer of the Following:

5X10=50m

9.(A) Explain different concepts of National Income.

(OR)

(B) Explain different methods of estimating National Income.:

10. (A) Explain the classical theory of Employment.

(OR)

(B) Explain the Keynesian consumption function.

11.(A) Explain the meaning and functions of Money.

(OR)

(B) Define Inflation. Explain its reasons.

12. (A) What are the function of the Reserve Bank of India

(OR)

(B) Explain the functions and importance of Stock Market

13 (A) What are different types of Life Insurance?

(OR)

(B) Explain about different phases of Trade Cycles.

AG&SG SIDDHARTHA DEGREE COLLEGE OF ARTS and SCIENCE
(AUTONOMOUS) VUYYURU

ACEDAMIC YEAR 2021 - 2022

SEMESTER – 4 :: COURSE – 4
ECONOMIC DEVELOPMENT- INDIA AND ANDHRA PRADESH

NO. OF CREDITS: 4

LEARNING OUTCOMES FOR THE COURSE

At the end of the course, the student is expected to demonstrate the following cognitive abilities and psychomotor skills.

1. Remembers and states in a systematic way (Knowledge)

a. leading issues of Indian economic development with reference to potential for growth, obstacles and policy responses

b. Objectives, outlays and achievements of economic plans and growth strategies

2. Explains (understanding)

a. Available Resources, demographic issues, general problems of poverty and unemployment and relevant policies

b. Sector specific problems, remedial policies and their effectiveness relating to Agriculture and Industrial Sectors of Indian and AP economy and infrastructure issues of AP economy

c. Indian Tax system, recent changes, issues of public expenditure and public debt, recent finance commissions and devolution of funds

d. Major issues of economic development of Andhra Pradesh after bifurcation and Central assistance

3. Critically examines using data and figures (analysis and evaluation)

a. Leading issues of current importance relating to India and AP economy, major policies and programmes

b. Covid– 19 and its impact on Indian economy

4. Uses official statistical data and reports including tables and graphs

a. To explain the achievements of Indian economy with reference to the objectives of planning and policy and make critical evaluation

AG&SG SIDDHARTHA DEGREE COLLEGE OF ARTS and SCIENCE
(AUTONOMOUS) VUYYURU

ACEDAMIC YEAR 2021 - 2022

SEMESTER – 4 :: COURSE – 4

ECONOMIC DEVELOPMENT- INDIA AND ANDHRA PRADESH

Module – 1 Basic Features Basic characteristics of Indian Economy as a developing economy – Economic development since independence - Objectives and achievements of planning – Planning Commission/NITIAyog and their approaches to economic development - India's Rank in Global Human Development Index .

Module 2 National Income and Demography Trends in National income - Demographic trends - Poverty and Inequalities – Occupational Structure and Unemployment - Various Schemes of employment generation and eradication of poverty – Issues in Rural Development and Urban Development –Intra-state and Inter-state Labour Migration and unorganized sector Problems of Migrant Labour.

Module – 3 Agricultural and Industrial Developments Indian Agriculture – Agricultural Strategy and Agricultural Policy – Agrarian Crisis and land reforms – Agricultural credit – Minimum Support Prices -Malnutrition and Food Security - Indian Industry - Recent Industrial Policy – Make-in India – Start-up and Stand-up programmes – SEZs and Industrial Corridors - Economic Reforms and their impact - Economic initiatives by government of India during COVID - Atmanirbhar Bharat package.

Module –4Indian Public Finance Indian Tax System and Recent changes – GST and its impact on Commerce and Industry – Centre, States financial relations- Recommendations of Recent Finance Commission – Public Expenditure and Public Debt - Fiscal Policy and Budgetary Trends

Module- 5Andhra Pradesh Economy The basic characteristics of Andhra Pradesh economy after bifurcation in 2014 – Impact of bifurcation on the endowment of natural resources and state revenue – new challenges to industry and commerce - the new initiatives to develop infrastructure – Power and Transport - Information Technology and e-governance – Urbanization and smart cities – Skill development and employment – Social welfare programmes.

Reference Books:

1. Dhingra, I.C., Indian Economy, Sultan Chand, New Delhi, 2014.
 2. Gaurav Datt and Ashwani Mahajan, Datt and Sundharam's Indian Economy, S.Chand & Co., 2016.
 3. G. M. Meier, Leading Issues in Economic Development, Oxford University Press, New York, 3/e.
 4. M. P. Todaro and Stephen C. Smith, Economic Development, 10/e, Indian Edition Published by Dorling Kindersley India Pvt. Ltd. 2012.
 5. P. K. Dhar, Indian Economy: Its Growing Dimensions, Kalyani Publishers, Ludhiana, 2018.
 6. Reserve Bank of India, Handbook of Statistics on Indian Economy (Latest).
 7. S.K.Misra & V.K.Puri, Indian Economy, Himalaya Publishing House, 2015.
 8. R.S.Rao, V.Hanumantha Rao & N.Venu Gopal (Ed.), Fifty Years of Andhra Pradesh (1956-2006), Centre for Documentation, Research and Communications, Hyderabad, 2007.
 9. G. Omkarnath, Economics - A Primer for India - Orient Blackswan, 2012.
 10. A.P Economy- Telugu Academy, 2018
- Recommended Co-curricular Activities:

1. Assignments on specific issues of contemporary importance with reference to problems and remedial policies
2. Student Seminars on leading economic challenges, the effectiveness of relevant policies and programmes
3. Quiz to examine the knowledge and critical understanding of major policies, programmes achievements, failures relating to all sectors
4. Group discussions to promote critical understanding and evaluation capabilities of the students on major areas of Indian and AP economy
5. Group project work to study the implementation and effectiveness of major government schemes of development, poverty eradication and employment promotion etc.,
6. PPT presentation and participation in webinars to help the students acquire and adapt ITC skills in the process of learning
7. Field Visits to Agricultural farm/market/SSIs to understand the ground realities of economic situation of the country and the state

**A.G. & S.G.SIDDHARTHA DEGREE COLLEGE OF ARTS & SCIENCE
(AUTONOMOUS) VUYYURU (2021 – 2022)**

MODEL QUESTION PAPER

B. A. ECONOMICS

II Year B. A. Programme (UG) Courses – Under CBCS

Semester – IV

PAPER CODE: ECO – 401C

PAPER TITLE :-ECONOMIC DEVELOPMENT- INDIA AND ANDHRA PRADESH

Duration: 3hrs

Maximum marks:70

Pass marks:28

Section:A

Answer any TWO of the following questions:

2x5= 10M

1. what is Global Human Development Index.
2. Concepts of Poverty.
3. Start – up Programmes
4. Skill India

Section:B

Answer any FOUR of the following questions:

4x15=60M

5. Discuss about Basic Characteristics of Indian Economy as a Developing Economy?
6. Write about the establishment of NITI Ayog? Explain its objectives?
7. Define poverty? Explain the causes for poverty and remedial measures to reduce the poverty in India
8. What is unemployment? Explain the causes for Unemployment and remedial measures to reduce the Unemployment in India.
9. Explain the Importance of Indian Agriculture sector in the Indian Economy.
10. Describe the Impact of Green Revolution on Indian Economy.
11. Discuss about GST Impact on commerce and Industry.
12. Discuss about Information Technology and E- Governance.

A.G. & S.G.SIDDHARTHA DEGREE COLLEGE OF ARTS & SCIENCE
(AUTONOMOUS), VUYYURU (2021-2022)

ECONOMIC DEVELOPMENT- INDIA AND ANDHRA PRADESH

The Guidelines to be followed by the question paper setters in **ECONOMIC DEVELOPMENT- INDIA AND ANDHRA PRADESH** for the 4th semester-end exams (2021 - 2022)

PAPER TITLE : --- **ECONOMIC DEVELOPMENT- INDIA AND ANDHRA PRADESH.**

PAPER CODE ;ECO -401C

Course – 4 Semester – IV Maximum marks : 70 Duration;3Hours

Weightage for the question paper

Syllabus	Section-A (Short answer questions)	Section-B (essay questions)
Unit-1 (35Marks)	1	2
Unit-2 (35Marks)	1	2
Unit-3 (35Marks)	1	2
Unit-4 (15Marks)	---	1
Unit-5 (20Marks)	1	1
TOTAL 140	20	120

- Each short answer question carries 5 marks in Section-A
- Each Essay question carries 15 marks in Section –B

The Question papers setters are requested to cover all the topics in the syllabus stipulated as per the weightage given by US.

AG&SG SIDDHARTHA DEGREE COLLEGE OF ARTS and SCIENCE
(AUTONOMOUS) VUYYURU

ACEDAMIC YEAR 2021 - 2022

COURSE– 5(Semester - IV)

STATISTICAL METHODS FOR ECONOMICS

NO. OF CREDITS: 4

LEARNING OUTCOMES FOR THE COURSE

At the end of the course, the student is expected to demonstrate the following cognitive abilities and psychomotor skills.

1. Remembers and states in a systematic way (Knowledge)
 - a. the definitions, terms and their meaning relating to statistical methods
 - b. various formulae used to measure central tendency, correlation regression and Indices
2. Explains (understanding)
 - a. Importance of statistics and its applications
 - b. The method of classification of primary data
 - c. Uses of Correlation and Regression analysis, time series and index numbers in economic analysis
3. Analyses and solves using given data and information (analysis and evaluation)
 - a. different kinds of statistical problems using various principles and formulae relating to central tendency, correlation, regression, time series and indices
 - b. to interpret data and suggest solutions to economic problems
4. Draws critical diagrams and graphs.
 - a. Histogram, Frequency Polygon and Frequency Curve
 - b. More than cumulative and less than cumulative frequency curves (Ogive)
 - c. Different types of Bar diagrams
 - d. Pie Diagram and its uses in economic analysis

AG&SG SIDDHARTHA DEGREE COLLEGE OF ARTS and SCIENCE
(AUTONOMOUS) VUYYURU

ACEDAMIC YEAR 2021 - 2022

COURSE– 5(Semester - IV)

STATISTICAL METHODS FOR ECONOMICS

NO. OF CREDITS: 4

Module – 1: Nature and Definition of Statistics Introduction to Statistics – Definition, scope, importance and limitations of Statistics – Primary and Secondary data- Census and Sampling techniques and their merits and demerits

Module – 2:Diagrammatic Analysis Collection of data - Schedule and questionnaire – Frequency distribution – Tabulation – diagram and graphic presentation of data – Histogram, Frequency Polygon, Cumulative Frequency Curves - Bar Diagrams and Pie Diagram

Module – 3:Measures of Central Tendency and Dispersion Measures of Central Tendency and Dispersion - Types of averages- Arithmetic Mean, Geometric Mean, Harmonic Mean – Median – Mode – Dispersion - Range, Quartile Deviation, Mean Deviation, Standard Deviation- Coefficient of Variation.

Module – 4:Correlation and Regression Correlation and Regression - Meaning, Definition and uses of Correlation- Types of Correlation- Karl Pearson’s Correlation coefficient - Spearman’s Rank CorrelationRegression Equations - utility of regression analysis – Demand forecasting.

Module – 5: Time Series and Index Numbers Time Series and Index Numbers: Definition and components of Time Series – Measurement of Time Series – Moving Average and the Least Squares Method – Index Numbers - Concepts of Price and Quantity Relatives – Laspeyer’s, Paasche’s and Fisher’s Ideal Index Numbers – Uses and Limitations of Index Numbers.

Reference Books:

1. B. R. Bhat, T. Srivenkataramana and K.S. MadhavaRao (1996): Statistics: A Beginner's Text, Vol. I, New Age International (P) Ltd.
2. Goon A.M, Gupta M.K., Das Gupta B. (1991), Fundamentals of Statistics, Vol. I, World Press, Calcutta.
3. M. R. Spiegel (1989): Schaum's Outline of Theory and Problems in Statistics, Schaum's Outline Series.
4. F. E. Croxton, D. J. Cowden and S. Kelin S (1973), Applied General Statistics, Prentice Hall of India. 2.
5. S.P. Gupta, Statistical Methods , S. Chand & Co, 1985
6. S. C. Guptha, Fundamentals of Statistics, Himalaya Publishing House, Hyderabad.
7. DigambarPatri and D. N. Patri, Statistical Methods for Economics, Kalyani Publishers, Ludhiana, 2017.
8. Telugu Akademy Book, ParimanathmakaPaddathulu (For B.A.).

Recommended Co-curricular Activities:

1. Assignments of the application of various statistical methods
2. Student Seminar on themes requiring usage of tables, diagrams, statistical analysis and interpretation
3. Group project work for collection of data on locally relevant economic problems
4. Market survey on demand, supply, sales, prices of different kinds of projects like food items, FMCG, other consumable durables etc., etc., and Statistical Analysis- Mini Project and also income elasticity of demand for such products

A.G. & S.G.SIDDHARTHA DEGREE COLLEGE OF ARTS & SCIENCE

(AUTONOMOUS) VUYYURU (2021 – 2022)

MODEL QUESTION PAPER

B. A. ECONOMICS

STATISTICAL METHODS FOR ECONOMICS

II Year B. A. Programme (UG) Courses – Under CBCS

Semester – IV

PAPER CODE: ECO – 402C

PAPER TITLE :-STATISTICAL METHODS FOR ECONOMICS

Duration: 3hrs

Maximum marks:70

Pass marks:28

Section:A

Answer any TWO of the following questions:

2x5= 10M

- 1.Characteristics of statistics
- 2.what is schedule? Explain its advantages.
3. what is meant by range? Explain its advantages and Limitations.
4. what is correlation.state it uses.

Section:B

Answer any FOUR of the following questions:

4x15=60M

5. what do you mean by primary and secondary data? What are the various methods used in collecting primary data?
6. what is mean by questionnaire? What are the features of good questionnaire?
7. write qualities or essentials of good average'

8. From the following data compute A.M

Marks :- 0 – 10 10 – 20 20 – 30 30 – 40 40 – 50 50 – 60

No.of students :- 5 10 25 30 20 10

9. Explain the need and importance of correlation?

10. Calculate the coefficient of correlation from the following data.

X :- 9 8 7 6 5 4 3 2 1

Y :- 15 16 14 13 11 12 10 8 9

11. What are the uses of Time series?

12. Compute Fisher's Ideal Index from the following data.

Commodity	1989		1990	
	price	quantity	price	quantity
A	4	40	5	50
B	8	64	9	80
C	10	70	10	70
D	2	10	4	16

A.G. & S.G.SIDDHARTHA DEGREE COLLEGE OF ARTS & SCIENCE
(AUTONOMOUS), VUYYURU (2021-2022)

STATISTICAL METHODS FOR ECONO

The Guidelines to be followed by the question paper setters in **STATISTICAL METHODS FOR ECONOMICS** for the 4th semester-end exams (2021 - 2022)

PAPER TITLE : --- **.STATISTICAL METHODS FOR ECONOMICS**

PAPER CODE ;ECO -402C

Course – 4 Semester – IV Maximum marks : 70 Duuration;3Hours

Weightage for the question paper

Syllabus	Section-A (Short answer questions)	Section-B (essay questions)
Unit-1 (20Marks)	1	1
Unit-2 (20Marks)	1	1
Unit-3 (35Marks)	1	2
Unit-4 (35Marks)	1	2
Unit-5 (30Marks)	---	2
TOTAL 140	20	120

- Each short answer question carries 5 marks in Section-A
- Each Essay question carries 15 marks in Section –B

The Question papers setters are requested to cover all the topics in the syllabus stipulated as per the weightage given by US.

A.G. & S.G.SIDDHARTHA DEGREE COLLEGE OF ARTS & SCIENCE
(AUTONOMOUS), (VUYYURU (2021-2022)

B. A. ECONOMICS

III Year B. A. Programme (UG) Courses – Under CBCS

Semester – VI

Paper – VII-(A) (Elective Paper VII-(A)

AGRICULTURAL ECONOMICS

Module-1

Nature and Scope of Agricultural Economics. Factors affecting agricultural development: technological, institutional and general. Interdependence between agriculture and industry.

Module-2

Concept of production function : input-output and product relationship in farm production.

Module-3

Growth and productivity trends in Indian agriculture with special reference to Andhra Pradesh. Agrarian reforms and their role in economic development.

Module-4

Systems of farming, farm size and productivity relationship in Indian agriculture with special reference to Andhra Pradesh- New agriculture strategy and Green revolution : and its Impact

Module-5

Emerging trends in production, processing, marketing and exports; policy controls and regulations relating to industrial sector with specific reference to agro-industries in agribusiness enterprises.

RECOMMENDED / REFERENCE BOOKS

1. Sadhu An, Singh Amarjit and Singh Jasbir (2014), Fundamentals of Agricultural Economics, Himalaya Publishing House, Delhi
2. Lekhi RK and Singh Joginder, Agricultural Economics, Kalyani Publishers
3. Bhaduri, A. (1984), The Economic Structure of Backward Agriculture, Macmillan, Delhi.
4. Bilgrami, S.A.R. (1996), Agricultural Economics, Himalayas publishing house, Delhi.
5. Dantwala, M.L. et.al (1991), Indian Agricultural Development Since Independence, Oxford & IBH, New Delhi.
6. Government of India (1976), Report of the National Commission on Agriculture, New Delhi. 5. Government of India, Economic Survey (Annual), New Delhi.
7. Gualti, A. and T. Kelly (1999), Trade Liberalisation and Indian Agriculture Oxford University Press, New Delhi

A.G. & S.G.SIDDHARTHA DEGREE COLLEGE OF ARTS & SCIENCE

(AUTONOMOUS) VUYYURU (2021 – 2022)

MODEL QUESTION PAPER

B. A. ECONOMICS

III Year B. A. Programme (UG) Courses – Under CBCS

Semester – VI (G.E)

PAPER CODE: ECO-601GE

Elective Paper VII-(A)

PAPER TITLE :- AGRICUTURAL ECONOMICS

Duration: 3hrs

Maximum marks:70

Pass marks:28

Section:A

Answer any TWO of the following questions:

2x5= 10M

1. objectives of Land Reforms.
2. organic farming
3. Production function
4. Rythu Bazar's

Section:B

Answer any FOUR of the following questions:

4x15=60M

5. Explain the importance of Agriculture sector in developing economies
6. what are the causes for low productivity in indian agriculture sector? Explain the actions to increase the agicultural productions.
7. what is land reform? Explain the objectives and importance of Land Reforms
8. what are the causes for low productivity in indian agriculture sector? Explain the actions to increase the agricultural productions.
9. what is Green Revolution? what are the causes for Green Revolution and explain the effects of green Revolution on Indian Economy.
10. what is cooperative forming? Explain the merits and demerits it?
11. Explain the problems in production, processing and marketing in indian agriculture sector?
12. Explain the Remedies and defects of agricultural marketing in India.

A.G. & S.G.SIDDHARTHA DEGREE COLLEGE OF ARTS & SCIENCE
(AUTONOMOUS), VUYYURU (2021-2022)

The Guidelines to be followed by the question paper setters in
Agricultural Economics for the 6th semester-end exams (2021 - 2022)

PAPER TITLE : --- **AGRICULTURAL ECONOMICS FINAL BA.**

PAPER CODE ;ECO-601GE

Paper- VII –(A)Semester – VI Maximum marks : 70 Duaration;3Hours

Weightage for the question paper

Syllabus	Section-A (Short answer questions)	Section-B (essay questions)
Unit-1 (30Marks)	--	2
Unit-2 (05Marks)	1	--
Unit-3 (35Marks)	1	2
Unit-4 (35Marks)	1	2
Unit-5 (35Marks)	1	2
TOTAL 140	20	120

- Each short answer question carries 5 marks in Section-A
- Each Essay question carries 15 marks in Section –B

The Question papers setters are requested to cover all the topics in the syllabus stipulated as per the weightage given by US.

A.G. & S.G.SIDDHARTHA DEGREE COLLEGE OF ARTS & SCIENCE
(AUTONOMOUS), VUYYURU (2021-2022)

B. A. ECONOMICS

III Year B. A. Programme (UG) Courses – Under CBCS

Semester – VI

Paper – VIII-A; Cluster Elective–A: Agribusiness

Paper VIII-A-1: Agribusiness Environment in Andhra Pradesh

Module-1

Role of agriculture in development process in Andhra Pradesh vis-à-vis other developed states. Economy wide effects of agriculture in Andhra Pradesh through trickle down effects. Backward and forward linkages of agriculture with rest of economy.

Module-2

Agricultural finance-importance in modern agriculture- performance of agricultural finance in Andhra Pradesh -problems of agricultural finance – Inter linkages of agricultural credit and other input markets and product markets.

Module-3

Dynamics of agriculture-crop (horticulture, field crops), sector-livestock (poultry dairy and fisheries) sector and inter linkages among the sectors. Agribusiness sector in Andhra Pradesh-salient features, constraints, sub sectors of agribusiness-input sector, production sector, processing sector.

Module-4

Growth performance of major agricultural commodities in Andhra Pradesh-production and processing trends in exports and imports of major agricultural commodities.

Module-5

Marketing policy- structure of agri markets – regulated markets – need – activities – structure – APMC act – market legislations – Role of Farmer Groups in the marketing of Agricultural Produce.

References:

1. Adhikary M. 1986. Economic Environment of Business. S. Chand & Sons.
2. Aswathappa K. 1997. Essentials of Business Environment.Himalaya Publ.
3. Francis Cherunilam 2003. Business Environment.Himalaya Publ.
4. Agarwal Raj, 2001, Business Environment, Excel Books, New Delhi.

**A.G. & S.G.SIDDHARTHA DEGREE COLLEGE OF ARTS & SCIENCE
(AUTONOMOUS), VUYYURU (2021 – 2022)**

MODEL QUESTION PAPER

B. A. ECONOMICS

III Year B. A. Programme (UG) Courses – Under CBCS

Semester – VIII (A - I)

PAPER CODE:ECO-602CE

PAPER TITLE - Agribusiness Environment in Andhra Pradesh

Duration: 3hrs

Maximum marks:70

Pass marks:28

Section:A

Answer any TWO of the following questions:

2x5=10M

- 1.
- 2.
- 3.
- 4.

Section:B

Answer any FOUR of the following questions:

4x15=60M

- 5.
- 6.
- 7.
- 8.
- 9.
- 10.
- 11.
- 12.

A.G. & S.G.SIDDHARTHA DEGREE COLLEGE OF ARTS & SCIENCE
(AUTONOMOUS), VUYYURU (2021-2022)

The Guidelines to be followed by the question paper setters in
Agribusiness Environment in Andhra Pradesh for the 6th semester-end
exams (2021 - 2022)

PAPER TITLE :-Agribusiness Environment in Andhra Pradesh III B.A

PAPER CODE ;ECO-602CE

PAPER –(VIII –A – I)Maximum marks : 70Duration;3Hours

Weightage for the question paper

Syllabus	Section-A (Short answer questions)	Section-B (essay questions)
Unit-1 (35Marks)	1	2
Unit-2 (35Marks)	1	2
Unit-3 (20Marks)	1	1
Unit-4 (30Marks)	--	2
Unit-5 (20Marks)	1	1
TOTAL 140	20	120

- Each short answer question carries 5 marks in Section-A
- Each Essay question carries 15 marks in Section –B

The Question papers setters are requested to cover all the topics in the syllabus stipulated as per the weightage given by us .

A.G. & S.G.SIDDHARTHA DEGREE COLLEGE OF ARTS & SCIENCE
(AUTONOMOUS), VUYYURU (2021 – 2022)

B. A. ECONOMICS

III Year B. A. Programme (UG) Courses – Under CBCS

Semester – VI

Paper – VIII-A; Cluster Elective – A:

Paper VIII-A-2: Agricultural Output Marketing

Module-1

Structure and Model of Agri-Marketing Organizations with functions: Functions of intermediaries, Marketing Practices in Primary and secondary and terminal market, Regulated markets, co-operative marketing.

Module-2

Marketing costs and margins, Marketing Finance. Marketing Structure of Major agricultural commodities, food grains: Rice, and Maize. Cash Crops; Cotton, Oil Seeds, Vegetables and Fruits, Milk, Meat and Poultry products.

Module-3:

Problems and Challenges in Agriculture Marketing - Market Yards - Support prices - Rural Warehousing.

Module-4:

State Intervention in Agricultural Marketing, Role of Various agencies (Andhra Pradesh Agro, MARKEED, State Department, and FCI, Tobacco Board, Cotton Corporation) and its impact on market efficiency. Agriculture Price Commission.

Module-5:

Inter-regional and international trade in agriculture; emerging scenario of international trade in agricultural commodities; concept of terms of trade and balance of payments, WTO and Indian agriculture with special reference to Andhra Pradesh .

References:

1. C.S.G.Krishnamacharyulu&LalithaRamakrishnan, “Rural Marketing: Text and Cases”, Pearson Education, New Delhi.
2. Awadhesh Kumar Singh &SatyaprakashPandey, Rural Marketing: Indian Perspective, New Age International Publishers, New Delhi.
3. Mamoria, C.B. &Badri Vishal: Agriculture Problems in India
4. Arora, R.C., “Integrated Rural Development”, S. Chand Limited, New Delhi.
5. Gopaldaswamy, T.P., “Rural Marketing: Environment, Problems and Strategies, Vikas Publishing House Pvt. Ltd., New Delhi.
6. Bedi&Bedi, “Rural Marketing”, Himalaya Publishing House, New Delhi.

A.G. & S.G.SIDDHARTHA DEGREE COLLEGE OF ARTS & SCIENCE
(AUTONOMOUS), VUYYURU (2021 – 2022)

MODEL QUESTION PAPER

B. A. ECONOMICS

III Year B. A. Programme (UG) Courses – Under CBCS

Semester – VI (VIII - A - 2)

PAPER CODE:ECO-603CE

PAPER TITLE – AGRICULTURAL OUTPUT MARKETING

Duration: 3hrs

Maximum marks:70

Pass marks:28

Section:A

Answer any TWO of the following questions:

2x5=10M

- 1.
- 2.
- 3.
- 4.

Section:B

Answer any FOUR of the following questions:

4x15 = 60M

- 5.
- 6.
- 7.
- 8.
- 9.
- 10.
- 11.
- 12.

A.G. & S.G.SIDDHARTHA DEGREE COLLEGE OF ARTS & SCIENCE
(AUTONOMOUS), (2021 - 2022) VUYYURU

The Guidelines to be followed by the question paper setters in **AGRICULTURAL OUTPUT MARKETING** for the 6th semester-end exams (2021 - 2022)

PAPER TITLE :-AGRICULTURAL OUTPUT MARKETINGIII B.A

PAPER CODE ;ECO - 603CE

PAPER – (VIII –A – 2) Maximum marks : 70 Duaration:3Hours

Weightage for the question paper

Syllabus	Section-A (Short answer questions)	Section-B (essay questions)
Unit-1 (35Marks)	1	2
Unit-2 (20Marks)	1	1
Unit-3 (15Marks)	--	1
Unit-4 (35Marks)	1	2
Unit-5 (35Marks)	1	2
TOTAL 140	20	120

- Each short answer question carries 5 marks in Section-A
- Each Essay question carries 15 marks in Section –B

The Question papers setters are requested to cover all the topics in the syllabus stipulated as per the weightage given by us .

A.G. & S.G.SIDDHARTHA DEGREE COLLEGE OF ARTS & SCIENCE

(AUTONOMOUS) VUYYURU (2021 – 2022)

PAPER CODE :- 604CE

SEMESTER - VI

ECONOMICS CLUSTER PAPER- 3 i.e.

Project Work

SUGGESTIVE TOPICS ON CURRENT ECONOMICS PROJECT

1. EVENT ECONOMICS PROJECT [2017-18]
2. CURRENT INDIA'S ECONOMIC EVENTS – WHAT'S GOING AROUND
3. BANK RECAPITALISATION PLAN
4. MAKE IN INDIA
5. DIGITAL INDIA
6. DISINVESTMENT –MUDRA YOJANA
7. SWADESH DARSHAN YOJANA
8. START UP INDIA
9. GST
10. DEMONETISATION
11. SELF HELP GROUP
12. INCLUSIVE GROWTH STRATEGY
13. INFLATION
14. INDIA - A VIBRANT MARKET FOR SOLAR INDUSTRY
15. NATIONAL INTELLECTUAL PROPERTY RIGHT POLICY 2016
16. HUMAN DEVELOPMENT INDEX
17. MICRO AND SMALL SCALE INDUSTRIES
18. BANK'S NPA [NON PERFORMING ASSETS].
19. IMPACT OF FREQUENT RISE IN PERTROL PRICES
20. SUBSIDIES
21. FOREIGN DIRECT INVESTMENT
22. SPECIAL ECONOMIC ZONE
23. INFRASTRUCTURE
24. DIGITAL MONEY WILL REPLACE PAPER MONEY

Last page

**A.G& S.G.SIDDHARTHA DEGREE COLLEGE OF ARTS &
SCIENCE**

VUYYURU-521165, KRISHNA Dt., A.P.(Autonomous)

Accredited by NAAC with "A" Grade

2021-2022



DEPARTMENT OF HISTORY

MINUTES OF BOARD OF STUDIES

ODD SEMESTER

30-10-2021



**A.G & S.G SIDDHARTHA DEGREE
COLLEGE OF ARTS AND
SCIENCE::VUYYURU**

(An Autonomous College in the Jurisdiction of Krishna University)
Accredited at the level 'A' by the NAAC
Sponsors: Siddhartha Academy of General & Technical Education

DEPARTMENT OF POLITICAL SCIENCE

Minutes of the meeting of Board of Studies in Political Science of A.G. & S.G Siddhartha Degree College of Arts & Science, Vuyyuru held at 10:00 AM on 30/10/2021 in the Department of Political Science

Members Present		
Name of the Member	Role	Signature
Smt. Ch. Sandhya Rani, HOD, Dept. of Political Science, A.G & S.G Siddhartha Degree College of Arts & Science, Vuyyuru-521165. Mobile: 9949402837 E-Mail: narasandhyarani@gmail.com	Chairman	
Sri. M. Padmanabham, Assistant Professor, Dept of Political Science, SRR & CVR Govt Degree College, Vijayawada. Mobile: 9490772836	University Nominee, Krishna University	
Smt G.Padmaja, Head, Department of Political Science, S.D.M. Siddhartha Mahila Kalasala, Vijayawada. Mobile: 9441883417	Academic Council Nominee	
Dr.G.Veerraju, H.O.D & Assistant Professor, Dept of Political Science, Y.V.N.R Govt. Degree College, Kaikaluru. Mobile: 9440476494	Academic Council Nominee	
Sri. R.V Siva Rao, Lecturer Dept. of Political Science, A.G & S.G Siddhartha Degree College of Arts & Science, Vuyyuru-521165. Mobile:9391380250	Academic Council Member	

AGENDA

1. To review and recommend changes to syllabi, model paper and guidelines in the 1st, 3rd and 5th semesters of B.A
2. To discuss about and recommend the pattern of assessment i.e., internal and external assessment percentage to be followed for Third Semester from academic year 2021-2022
3. To recommend the the guidelines to be followed by the Question Paper Setters in Political Science for all semester-end exams.
4. To recommend the teaching and the evaluation methods to be followed under the Autonomous System.
5. To Suggest innovative methods of teaching
6. To propose the panel of Question Paper Setters and Examiners.

RESOLUTIONS

Following resolutions are made in the Board of Studies in Political Science :

- 1.) To continue with the existing syllabi for first semester with out any change for the academic year 2021-22.
- 2.To Continue with the existing syllabi for third Semester without any change for the academic year 2021-22.
- 3) To continue with the existing syllabi for 5th semester without any change for the Academic Year 2021-2022.
- 4) To adapt 25 marks for internal assessment and 75 marks for external assessment for 1st Degree and 30 marks for internal assessment and 70 marks for external assessment for 2nd and 3rd year Degree from the Academic Year 2021-2022.
- 5) To follow the new model question paper from the Academic Year 2021-2022 for all the B.A Students
- 6) To adapt the following teaching and evaluation methods:

Teaching Methods:

Besides the conventional methods of teaching, it is also resolved to use various other methods like group discussions, quiz, developing power point presentation etc., for the better understanding of the contents.

Evaluation Method for Internal Theory Examination for 1st B.A students

First Internal Exam	Second Internal Exam	Average	Attendance	Total
A	B	$C=(A+B) / 2$	D	(C+D)
20 Marks	20 Marks	20 Marks	5 Marks	25 Marks

Evaluation Method for Internal Theory Examination for 2nd and 3rd B.A students

First Internal Exam	Second Internal Exam	Average	Assignment	Attendance	Total
A	B	$C=(A+B) / 2$	D	E	(C+D+E)
20 Marks	20 Marks	20 Marks	5 Marks	5 Marks	30 Marks

- 7) Semester End Examinations:

- 8) The maximum marks of sem-end examinations for 1st B.A are 75 and for 2nd and 3rd B.A students are 70 Marks from the Academic Year 2021-2022 for all the B.A Students and the duration of the examination shall be 3 Hours.
- 9) To Organize Seminars ,Guest Lectures and Workshops to upgrade the knowledge of the students and to impart new skills of learning as frequently as possible.
- 10) To authorize the chairman of board of studies to suggest the panel of paper setters and examiners to the controller of examinations as per the requirement.

A.G &S.G SIDDHARTHA DEGREE COLLEGE OF ARTS & SCIENCE VUYYURU-521165

(An Autonomous College in the jurisdiction of Krishna University , Machilipatnam)

Title of the paper: INTRODUCTION TO POLITICAL SCIENCE

Semester-I

Course Code	POLTIIB	Course Delivery Method	Class Room
Credits	4	CIA Marks	25
No.of Lecture Hours/Week	5	Semester End Exam Marks	75
Total Number of Lecture Hours	60	Total Marks	100
Year of Introduction 2020-2021	Year of offering 2021-2022	Year of Revision 2021-2022	Percentage of Revision 0%

Course Context and overview: To train students in order to have clear understanding of politics, related concepts such as government, state sovereignty, legitimacy, power, influence, authority, democracy, power, political participation, political system etc.

COURSE OUTCOMES: INTRODUCTION TO POLITICAL SCIENCE

Course Outcomes: At the end of the course the student will be able to:

CO1: Define important field-specific theories and concepts, and understand their role in developing political science Knowledge: L-1 , L-2

CO2: Summarize conceptual arguments or theoretical approaches. L-3 , L-4

CO3: Apply them to field relevant situations and support their application with appropriate evidence. L-3, L-4

CO4: Compare and evaluate the merits of multiple policies, theories or concepts from different disciplinary perceptions. L-5

CO5: With the course, students are expected to learn the political concepts and theory in the Basic Concepts of Political Science. L-1, L-2

Learning Outcome:

On successful completion of the course the students will be able to:

- Recall the previous knowledge about Political Science and understand the nature and scope, traditional and modern approaches of Political Science.
- Understand concepts intrinsic to the study of Political Science.
- Have a solid theoretical understanding of Rights and its theories along with the basic aspects of certain political ideologies.
- Apply the knowledge to observe the field level phenomena.

UNIT:I INTRODUCTION:

15hrs.

1. Definition, Nature, Scope and Importance of Political Science - Relations with allied Disciplines (History, Economics, Philosophy and Sociology)
2. Approaches to the study of Political Science:
Traditional Approaches- Historical, Normative and Empirical Approaches.
Modern Approaches:Behavioral and System Approach.

UNIT-II: STATE :

15 hrs

Definition of the State, Elements of the State, Theories of Origin of the State-(Divine Origin , Force, Evolutionary and Social Contract),

1. Concepts of Modern State and Welfare State.

UNIT-III: CONCEPTS OF POLITICAL SCIENCE:

10 hrs

1. Law, Liberty,
2. Power, Authority and Legitimacy

UNIT:IV: THEORIES OF RIGHTS:

10 hrs

2. Meaning, Nature and Classification of Rights
3. Theories of Rights.

UNIT:V:POLITICAL IDEOLOGIES:

10 hrs

1. Liberalism, Individualism and Anarchism.
2. Socialism, Marxism and Multiculturalism.

REFERENCE BOOKS:

1. Sukhbir Bhatnagar : Constitutional Law and the Governance
2. A. C. Kapur : Select Constitution
3. R.C. Agarwal : Political Theory
4. Vidyadhar Mahajan : Political Theory(Principles of Pol.Sci.
5. Devi & V. Bhogendra Acharya,
6. Prof. V. Ravindra Sastry (ed) : Political Science Concepts, Theories & Institutions.
7. Jadi Musalaiah, V. Vasundhara
8. Laski H.J. : Grammar of Politics
9. A. Appadorai : Substance of Politics
10. Eddy Ashirvadam K.K. Misra : Political Theory
11. Sushila Ramaswamy : Political Theory: Ideas & Concepts
12. S.P. Varma : Modern Political Theory
13. O.P. Gauba : An Introduction to Political Science
14. Abbas, Hoveyda & Ranjay Kumar : Political Theory
15. Andrew Hakes : Political Theory, Philosophy, Ideology Science.
16. Rajeev Bhargava & Ashok Acharya (ed) : Political Theory An Introduction
17. Andrew Heywood : Political Ideologies-An Introduction
18. Norman Barry : An Introduction to Modern Political theory.

(An Autonomous college in the jurisdiction of Krishna University, Machilipatnam)

Reaccredited at 'A Grade by NAAC

MODEL QUESTION PAPER (Semester-I) Course Code : POLTIIB

Time: 3 Hours

Max. Marks : 75

SECTION –A

Answer any five of the following questions.

Each carries **FIVE** marks :

(5X5=25 Marks)

- 1.What is Political Science? L1- CO1
- 2.System Approach? L1 - Co1
- 3.Explain Divine Origin Theory. L1 – L2-Co2
- 4.Discuss 'Hobbes views on Human Nature. L5-Co2
- 5.Describe the features of Welfare State. L5 – CO2
6. Explain the features of Modern State. L2-CO2
- 7.Explain the meaning and sources of Law. L2-Co3
8. Explain the types of Authority. L2,CO3

SECTION –B

Answer the following : Each carries TEN marks.

(5x10=50 Marks)

9.(a) Define Political Science and explain its Scope. L1-CO1

(or)

(b)Explain the 'Normative Approach ' to the study of Political Science. L2-L4-CO1

10 (a)Define State and Elements its characteristics. Co2-L1

(or)

(b) Critically examine the Social Contract Theory of Hobbes. L1-L2-CO1

11. (a) What is Liberty? What are the kinds of Liberty? L2-L4-CO3

(or)

(b) Define Legitimacy and kinds of Legitimacy. L1-L2-COC03

12. (a) 'Rights and Duties are the two sides of the same Coin' - Discuss,. L1-L5-Co4

(or)

(b) Define Right and discuss various kinds of Rights.. L2-CO4

13. (a) Critically examine 'Communism'. L5-Co5

(or)

(b) Explain the "Multiculturalism". L2-L3-Co1-Co5

New syllabus

B.A. POLITICAL SCIENCE SECONDYEAR

THIRD SEMESTER (Under CBCS w.e.f2020-21)

Course-3: INDIAN GOVERNMENT AND POLITICS

Course Code	POLT301C	Course Delivery Method	Class Room
Credits	4	CIA Marks	30
No.of Lecture Hours/Week	5	Semester End Exam Marks	70
Total Number of Lecture Hours	60	Total Marks	100
Year of Introduction2020-2021	Year of offering 2021-2022	Year of Revision 2021-2022	Percentage of Revision 0%

Course Outcomes:

CO1: The students community has acquired knowledge of the making of the Indian Constitution and its philosophical background. L1

CO2: Information about the functionaries of the government both at the union and state level was acquainted by the student community.L1, L2

CO3.To Understand the legislative procedures which ensure the orderly conduct of business in our parliament and state legislative assemblies in **India.**

CO4: To understand know the Ministers, their role &responsibilities.L1,

CO5: To understand Judiciary of India.L1, L2

Learning Outcomes:

On successful completion of the course the students will be able to:

- Acquire knowledge about the historical background of Constitutional development in India, appreciate philosophical foundations and salient features of the Indian Constitution.

- Analyze the relationship between State and individual in terms of Fundamental Rights and Directive Principles of State Policy.
- Understand the composition and functioning of Union Government as well as State Government and finally
- Acquaint themselves with the judicial system of the country and its emerging trends such as judicial reforms.

UNIT-I :	SOCIAL AND IDEOLOGICAL BASE OF THE INDIAN CONSTITUTION	15 hrs
	1. Constitutional Development in India during British Rule-A Historical	
	2. Constituent Assembly-Nature, Composition, Socio-Economic,	
	Philosophical Dimensions and Salient Features of the Indian	

UNIT-II	INDIVIDUAL AND STATE	15 hrs
	1. Fundamental Rights, Directive Principles of State Policy and Fundamental Duties-Differences between Fundamental Rights and Directive Principles of State Policy.	
	2. The 'Doctrine of Basic Structure of the Constitution' with reference to Judicial Interpretations and Socio-Political Realities.	

UNIT-III :	UNION EXECUTIVE	10 hrs
	1. President of India-Mode of Election, Powers and Functions.	
	2. Parliament-Composition, Powers and Functions, Legislative Committees, Prime Minister and Council of Ministers-Powers and	

UNIT-IV :	STATE EXECUTIVE	10 hrs
	1. Governor-Mode of Appointment, Powers and Functions.	
	2. Legislature-Composition, Powers and Functions, Chief Minister and	

UNIT-V :	THE INDIAN JUDICIARY	10 hrs
	1. Supreme Court-Composition and Appointments, Powers and	
	Functions or Jurisdiction of the Supreme Court, Judicial Review, Judicial	
	2. High Court-Composition, Powers and Functions, Debates on the	
	mode of appointment of Judges-National Judicial Appointments	

**A.G &S.G SIDDHARTHA DEGREE COLLEGE OF ARTS & SCIENCE
[AUTONOMOUS] VUYYURU-521165**

SEMESTER-III CODE-POLT301C ACADEMIC YEAR-2020-2021

PAPER TITLE:INDIAN GOVERNMENT AND POLITICS

Duration: 3 Hours Maximum Marks:70 Pass Marks:28

Section-A

Answer any **Two** of the following questions (2x5=10 Marks)

1. Explain the Indian Government act of 1935.
2. Describe the Fundamental duties of Indian citizens.
3. Discuss the various Legislative committees.
4. Judicial Review.

Section-B

Answer any **Four** of the following questions (4x15=60 Marks)

5. Explain the salient features of the Indian Constitution.
6. Explain the Fundamental Rights of the Constitution.
7. Explain the powers and Functions of the President of India.
8. Explain the powers and Functions of Chief Minister.
9. Describe the structure and Functions of Supreme Court of India.
10. Explain the powers and Functions of Prime Minister.
11. Explain the Directive Principles of the state policy in Indian Constitution.
12. Explain the powers and Functions of Governor.

**A.G. & S.G.SIDDHARTHA DEGREE COLLEGE OF ARTS &
SCIENCE (AUTONOMOUS), (2020-21) VUYYURU**
PAPER TITLE : PAPER-V (CORE): INDIAN POLITICAL THOUGHT

Course Code	POL501C	Course Delivery Method	Class Room
Credits	4	CIA Marks	30
No.of Lecture Hours/Week	5	Semester End Exam Marks	70
Total Number of Lecture Hours	60	Total Marks	100
Year of Introduction2020-2021	Year of offering 2021-2022	Year of Revision 2021-2022	Percentage of Revision 0%

Course outcomes :

CO1: *It helps* students discover the political philosophy that forms the basis of politics in the Indian Political Thought , to interpret the political philosophies of the Ancient Indian and Medieval philosophers in historical context as well as relate them to contemporary politics.

CO2: Origin of the knowledge in the Indian political thought.

CO3: To understand the political thoughts in medieval period and how it laid foundation to modern.

CO4: To demonstrate how government politics people by democracy and individual people.

CO5: To demonstrate individual freedom and Theory of sarvodaya.

Learning outcomes:

On successful completion of the course the students will be able to:

- Understand the fundamental course classical, Indian political phil, basic features of medieval political thought and shift from medieval to modern era.
- Understand the Gandhi and Political Theory and appreciate its implications on the perception of State in terms of its purposes and role.
- Acquaint with the Liberal and M.N Roy human radicalism and Jayaprakash Narayana Political Ideas

- critically analyze the evolution of Indian political thought.

Unit -I: **15Hrs**

1. Manu: Social laws ,dandaneethi
2. Kautilya : kingship, Mandala Theory, Saptanga Theory

UNIT – II **15HRS**

1. Gandhi:
 - a.Non-violence, Satyagraha.
 - b.Theory of Trusteeship.
2. JoythiRao Pule: - Social reform

UNIT – III **15HRS**

Nehru:

- a. Democratic Socialism.
- b.Non-Alignment

Ambedkar:

- a.Views on Indian Society.
- b.Social Movements.

UNIT – IV **15HRS**

M.N. Roy:

- Radical Humanism

Jaya Prakash Narayan:

- Total Revolution.
- Sarvodaya.

Text Books

1. “Rajaneethi Thatvavicharam”: A Text Book by Telugu Academy.

Reference books:

1. Pantham Thomas and Kenneth Deutsch(Ed)(1986)
Political thought in modern India, Sage, New Delhi
2. BidyutChakrabarthy and Rajendra Kumar Pandey (2009) modern Indian political thought, Sage, New Delhi
3. GurpreetMahajan (2013), India : Political ideas and making of a democratic discourse, zed book, London

4. ParthaChatterjee (1986) nationalist thought and the colonial world: A derivative disclosure, zed books, London
5. Bhikhu Parekh (1999) colonialism, tradition and reform,Sage,New Delhi
6. BhikhuParekh(1989) Gandhi's political philosophy ,Macmillan, London.

**AG & SG SIDDHARTHA DEGREE COLLEGE OF ARTS AND SCIENCE,
VUYYURU**

**(AN AUTONOMOUS COLLEGE IN THE JURISDICTION OF KRISHNA
UNIVERSITY, MACHILIPATNAM, A.P)**

POLITICAL SCIENCE	POL 501C	2020-21	III BA
--------------------------	-----------------	----------------	---------------

EXAMINATION AT THE END OF FIFTH SEMESTER

SEMESTER – V

TIME: 3 HRS

PAPER – V

MAX. MARKS: 70

Model Paper

Indian Political Thought

Section – A

I. ANSWER any TWO OF THE FOLLOWING.

(2 × 5 = 10)

- 1) DANDA NEETHI.
- 2) write about Koutilya's Saptanga.
- 3) Explain Gandhi's Theory of Trusteeship
- 4) DR. AMBEDKAR'S ANNIHILATION OF CASTE.

Section – B

Answer any FOUR of the following.

(4 × 15 = 60)

- 5) Explain Manu's classification of Varna.
- 6) Explain the mandala theory of kautilya.
- 7) State and criticize Gandhi's satyagraha and non-violence.
- 8) Write an essay on social movements led by Dr. Ambedkar.
- 9) Write an essay on mahatma Jyothirao Phule
- 10) Discuss Jawaharlal Nehru's views on Democratic Socialism.
- 11) Briefly explain Jaya Prakash Narayan's total revolution
- 12) Write about M.N. Roy's radical humanism

A.G & S.G SIDDHARTHA DEGREE COLLEGE of Arts & Science

VUYYURU-521165

(An Autonomous college in the Jurisdiction of Krishna University, Machilipatnam)

Political science	POL501C	III B.A
--------------------------	----------------	----------------

Subject: Indian Political Thought

Semester-V

Paper-V

Guidelines to the paper setter

SECTION	Unit-I	Unit-II	Unit-III	Unit-IV
A 5 Marks Questions	2	1	1	
B 15 Marks Questions	2	2	2	2
Weight age	40	35	35	30

**A.G. & S.G.SIDDHARTHA DEGREE COLLEGE OF ARTS & SCIENCE
(AUTONOMOUS), (2020-21) VUYYURU**

PAPER TITLE : PAPER-VI (CORE): WESTERN POLITICAL THOUGHT

Course Code	POL502C	Course Delivery Method	Class Room
Credits	4	CIA Marks	30
No.of Lecture Hours/Week	5	Semester End Exam Marks	70
Total Number of Lecture Hours	60	Total Marks	100
Year of Introduction2020-2021	Year of offering 2021-2022	Year of Revision 2021-2022	Percentage of Revision 0%

Course outcomes :

CO1: It helps students discover the political philosophy that forms the basis of politics in the Western world, to interpret the political philosophies of the Greek, Roman , French, English and German philosophers in historical context as well as relate them to contemporary politics.

CO2: Origin of the knowledge in political thought.

CO3: To understand the political thoughts in medieval period and how it laid foundation to modern.

CO4: To demonstrate how government politics people by democracy and individual people.

CO5: To demonstrate individual freedom, surplus value, materialist.

Learning outcomes:

On successful completion of the course the students will be able to:

- Understand the fundamental contours classical, western political philosophy, basic features of medieval political thought and shift from medieval to modern era.
- UnderstandtheSocialContractTheoryandappreciateitsimplicationsontheperception of State in terms of its purposes and role.
- AcquaintwiththeLiberalandMarxistphilosophyandanalyzesometrends in Western Political Thought.

- Critically analyse the evolution of western political thought.

Unit-I: Plato: 15Hrs
 a. Theory of Justice
 b. Education System
 c. Philosopher -King
 d. Theory of Communism

Unit-II: Aristotle: 15Hrs
 a. Ideal state
 b. Theory of Revolutions.
 c. Classification of governments

Unit-III: 15Hrs
 1. Machiavelli-political Ideas, Advice to the Prince
 2. Thomas Hobbes: Human nature, Social Contract, Sovereignty
 3. John Locke: Natural Rights and Social Contract,
 4. Rousseau: Social Contract and General Will

Unit-IV: 15Hrs
 1. **Hegel:** Civil Society, State
 2. **Karl Marx:** Surplus Value, History of Dialectical Materialism, State

Reference books:

1. Shefali Jha (2010) Western Political Thought from Plato to Karl Marx, Pearson, and New Delhi
2. Boucher D and Kelly P (Eds) (2009) Political Thinkers from Socrates to the Present, Oxford University press, oxford
3. Coleman J (2000) A History of Modern Political Thought: From Ancient Greece to early Christianity, Blackwell publishers, oxford
4. Macpherson C B (1962) The Political Theory of Possessiveness Individualism, Oxford University press, oxford
5. Hampsher-monk I (2001) A History of Modern Political Thought: Major Political Thinkers From Hobbers to Marx, Blackwell publishers, oxford

AG & SG SIDDHARTHA DEGREE COLLEGE OF ARTS AND SCIENCE, VUYYURU
(AN AUTONOMOUS COLLEGE IN THE JURISDICTION OF KRISHNA
UNIVERSITY, MACHILIPATNAM, A.P)

POLITICAL SCIENCE	POL 502C	2020-21	III BA
-------------------	----------	---------	--------

EXAMINATION AT THE END OF FIFTH SEMESTER

SEMESTER – V

TIME: 3 HRS PAPER
MAX. MARKS: 70

Model paper

Western political thought

Section – A

I. Answer any two of the following **(2 × 5 = 10)**

- 1) Philosopher-king
- 2) What are the views of hobbes on human nature.
- 3) Theory of natural rights
- 4) Examine mark's views on class War

Section – B

II. Answer any Four of the following. **(4 × 15 = 60)**

- 5) Explain the features of plato's education
- 6) Analyze aristotle's views on revolutions.
- 7) What are qualities of a Prince suggested by Machiavelli?
- 8) Social Contract Theory of Rousseau
- 9) Social Contract Theory of Hobbes
- 10) Explain Plato's Theory of Justice
- 11) Plato system of education
- 12) Karl Marx's Theory of Communism.

AG & SG SIDDHARTHA DEGREE COLLEGE of Arts & Science

VUYYURU-521165

(An Autonomous college in the Jurisdiction of Krishna University, Machilipatnam)

Political science	POL-502C	IIB.A
--------------------------	-----------------	--------------

Subject: western Political thought

Semester-V

Paper-VI

Guidelines to the paper setter

SECTION	Unit-I	Unit-II	Unit-III	Unit-IV
A 5 Marks Questions	1		2	1
B 10 Marks Questions	2	2	3	1
Weight age	35	30	55	20

Note: In view of vast syllabus more weightage given to **unit-III**

**A.G& S.G.SIDDHARTHA DEGREE COLLEGE OF ARTS &
SCIENCE**

VUYYURU-521165, KRISHNA Dt., A.P.(Autonomous)

Accredited by NAAC with "A" Grade

2021-2022



DEPARTMENT OF POLITICAL SCIENCE

MINUTES OF BOARD OF STUDIES

EVEN SEMESTER

31-03-2022



A.G & S.G SIDDHARTHA DEGREE COLLEGE OF ARTS AND SCIENCE::VUYYURU

(An Autonomous College in the Jurisdiction of Krishna University)

Accredited at the level 'A' by the NAAC

Sponsors: Siddhartha Academy of General & Technical Education

DEPARTMENT OF POLITICAL SCIENCE

Minutes of the meeting of Board of Studies in Political Science of A.G. & S.G Siddhartha Degree College of Arts & Science, Vuyyuru held at 10:00 A.M on 31/3/2022 in the Department of Political Science

Members Present		
Name of the Member	Role	Signature
Smt. Ch. Sandhya Rani, HOD, Dept. of Political Science, A.G & S.G Siddhartha Degree College of Arts & Science, Vuyyuru-521165. Mobile: 9949402837 E-Mail: narrasandhyarani@gmail.com	Chairman	
Sri. M. Padhmanabham, Assistant Professor, Dept of Political Science, SRR & CVR Govt Degree College, Vijayawada. Mobile: 9490772836	University Nominee, Krishna University	
Smt G.Padmaja, Head, Department of Political Science S.D.M. Siddhartha Mahila Kalasala, Vijayawada. Mobile: 9441883417	Academic Council Nominee	
Dr.G.Veerraju, Associate Professor, Dept of Political Science, & Public Administration, Andhra University, Visakapatnam. Mobile: 9440476494	Academic Council Nominee	
Sri. R.V.Siva Rao, Lecturer Dept. of Political Science, A.G & S.G Siddhartha Degree College of Arts & Science, Vuyyuru-521165. Mobile:9391380250	Academic Council Member	

AGENDA

1. To review and recommend changes to syllabi, model paper and guidelines in the 2nd, 4th and 6th semesters of B.A
2. To discuss about and recommend the pattern of assessment i.e., internal and external assessment percentage to be followed for Third Semester from academic year 2021-2022
3. To recommend the the guidelines to be followed by the Question Paper Setters in Political Science for all semester-end exams.
4. To recommend the teaching and the evaluation methods to be followed under the Autonomous System.
5. To Suggest innovative methods of teaching
6. To propose the panel of Question Paper Setters and Examiners.

RESOLUTIONS

Following resolutions are made in the Board of Studies in Political Science :

- 1) It is resolved continue the exiting syllabus with out any chanes for II semester.
- 2) It is resolved to introduce INDIAN POLITICAL PROCESS in the place of INDIAN CONSTITUTION for semester-IV for the 2nd Degree from the Academic Year 2021-2022.
- 3) It is resolved to introduce WESTREN POLITICAL THOUGHT for semester-IV for the 2nd Degree from the Academic Year 2021-2022.
- 4) To continue with the existing syllabi for 6th semester without any change for the Academic Year 2021-2022.
- 5) To adapt 25 marks for internal assessment and 75 marks for external assessment for 1st Degree and 30 marks for internal assessment and 70 marks for external assessment for 2nd and 3rd year Degree from the Academic Year 2021-2022.
- 6) To follow the new model question paper from the Academic Year 2021-2022 for all the B.A Students
- 7) To adapt the following teaching and evaluation methods:

Teaching Methods:

Besides the conventional methods of teaching, it is also resolved to use various other methods like group discussions, quiz, developing power point presentation etc., for the better understanding of the contents.

Evaluation Method for Internal Theory Examination for 1st B.A students

First Internal Exam	Second Internal Exam	Average	Attendance	Total
A	B	$C=(A+B) / 2$	D	(C+D)
20 Marks	20 Marks	20 Marks	5 Marks	25 Marks

Evaluation Method for Internal Theory Examination for 2nd and 3rd B.A students

First Internal Exam	Second Internal Exam	Average	Assignment	Attendance	Total
A	B	$C=(A+B) / 2$	D	E	(C+D+E)
20 Marks	20 Marks	20 Marks	5 Marks	5 Marks	30 Marks

8) Semester End Examinations:

- 9) The maximum marks of sem-end examinations for 1st B.A are 75 and for 2nd and 3rd B.A students are 70 Marks from the Academic Year 2021-2022 for all the B.A Students and the duration of the examination shall be 3 Hours.
- 10) To Organize Seminars ,Guest Lectures and Workshops to upgrade the knowledge of the students and to impart new skills of learning as frequently as possible.
- 11) To authorize the chairman of board of studies to suggest the panel of paper setters and examiners to the controller of examinations as per the requirement.

A.G. & S.G.SIDDHARTHA DEGREE COLLEGE OF ARTS & SCIENCE
(AUTONOMOUS), (2021-2022) VUYYURU

BASIC ORGANS OF THE GOVERNMENT (NEW)

Programme : B.A.(T.M)

Semester - II

Year: I year(2020-2021)

Course Code :(POLT21)

Credits :4

Hours: 60

Course Context and Overview:

The aim of studying this course is to know that the constitution of India is the supreme law of India. The document lays down the framework demarcating fundamental political code, structure, procedures, powers and duties of government institutions and set out fundamental rights, directive principles and the duties of citizens.

COURSE TITLE: BASIC ORGANS OF THE GOVERNMENT

Course Outcomes: At the end of the course the student will be able to:

1. To demonstrate and describe the salient features of the constitution of India interpret, integrate the salient and critically analyse the political economy of Indian Constitution.L1-L2
2. To understand the historical growth of the idea of fundamental human rights and create an awareness on directive principles of state policy.L1-L5
- 3.Acquaint themselves with different theories of origin of State.L2
4. To define federation and its features in Indian constitution and how it divides power between union and state governments, legislations, administrative and financial spheres and recommendations of Sarkaria Commission.L1-L2
5. To learn the contents of Indian constitution and how the supreme court and other court functions and develop an awareness foreign and state constitutions.L5

Learning Out comes:On successful completion of the course the students will be able to:
Understand the Origin and Evolution of the concept of Constitutionalism and classification of Constitutions. Acquaint themselves with different theories of origin of State.

- Understand and analyse organs and form of Government along with a deep insight into the various agents involved in the political process. Apply the knowledge to analyse and evaluate the existing systems.

**A.G. & S.G.SIDDHARTHA DEGREE COLLEGE OF ARTS & SCIENCE
(AUTONOMOUS), (2021-2022) VUYYURU**

BASIC ORGANS OF THE GOVERNMENT (NEW)

Programme : B.A.(T.M)

Semester – II

Year: I year(2020-2021)

Credits :4

Course Code :(POLT21)

Hours: 60

Course Context and Overview:

The aim of studying this course is to know that the constitution of India is the supreme law of India. The document lays down the framework demarcating fundamental political code, structure, procedures, powers and duties of government institutions and set out fundamental rights, directive principles and the duties of citizens.

COURSE TITLE: BASIC ORGANS OF THE GOVERNMENT

Course Outcomes: At the end of the course the student will be able to:

1. To demonstrate and describe the salient features of the constitution of India interpret, integrate the salient and critically analyse the political economy of Indian Constitution.L1-L2
2. To understand the historical growth of the idea of fundamental human rights and create an awareness on directive principles of state policy.L1-L5
- 3.Acquaint themselves with different theories of origin of State.L2
4. To define federation and its features in Indian constitution and how it divides power between union and state governments, legislations, administrative and financial spheres and recommendations of Sarkaria Commission.L1-L2
5. To learn the contents of Indian constitution and how the supreme court and other court functions and develop an awareness foreign and state constitutions.L5

Learning Out comes:On successful completion of the source the students will be able to: Understand the Origin and Evolution of the concept of Constitutionalism and classification of Constitutions, Acquaint themselves with different theories of origin of State.

- Understand and analyse organs and form of Government along with a deep insight into the various agents involved in the political process. Apply the knowledge to analyse and evaluate the existing systems.

**A.G. & S.G.SIDDHARTHA DEGREE COLLEGE OF ARTS & SCIENCE
(AUTONOMOUS), (2021-2022) VUYYURU**

POLITICAL SCIENCE	POLT21B	2021-2022	B.A(TM)
-------------------	---------	-----------	---------

BASIC ORGANS OF THE GOVERNMENT (NEW SYLLABUS)

SEMESTER-II

No.of Credits:4

60 hours

UNIT-I:

CONSTITUTION

1. Meaning, Definition, Origin and Evolution of Constitution. 15 hrs
2. Classion of the Constitutions - Written and Unwritten, Rigid and Flexible.

UNIT:II :

ORGANS OF THE GOVERNMENT

1. Theory of Separation of Powers - B.D. Montesquieu. 15 hrs
2. Legislature - Unicameral and Bicameral - Powers and Functions, EXecutive - Types, Powers and Functions.
3. Judiciary - Powers and Functions.

UNIT- III:

FORMS OF GOVERNMENT

1. Unitary and Federal forms of Governments - Merits and Demerits. 10 hrs
2. Parliamentary and Presidential forms of Governments - Merits and Demerits.

UNIT:IV:

DEMOCRACY

1. Meaning, Definition, Significance, Theories and Principles of Democracy. 10 hrs
2. Types of Democracy: Direct and Indirect Democracy - Methods, Merits and - Essential Conditions for Success of Democracy.

UNIT - V: POLITICAL PARTIES, PRESSURE GROUPS AND PUBLIC OPINION 10 hrs

1. Meaning, Definition and Classification of Political Parties: National and Regional - Functions of Political Parties.
2. Pressure Groups (Interest Groups) - Meaning, Definition, Types, Functions and Significance of Public Opinion.

4. Vidyadhar Mahajan
 5. M.R..Biju
 6. Peter Ronald de Souza & E. Sreedharan (ed).
 - 7 . Jadi Musalaiah, V.Vasundhara Devi & V. Bhogendra Acharya, Prof. V. Ravindra Sastry (ed)
 8. Laski H.J.
 9. A.Appadorai
 - 10.Eddy Ashirvadam K.K.Misra
 - 11.Sushila Ramaswamy
 - 12.S.P. Varma
- : Political Theory(Principles of Pol.Sci.
: Democratic Political Process
- : Indian Political Parties
- : Political Science Concepts,Theories &
Institutions.
- : Grammar of Politics
- :Substance of Politics
- :Political Theory
- :Political Theory: Ideas & Concepts
- : MODern Political Theory

**A.G. & S.G.SIDDHARTHA DEGREE COLLEGE OF ARTS & SCIENCE
(AUTONOMOUS), (2021-2022) VUYYURU**

MODEL QUESTION PAPER (Semester-II)

Course Code : POLT21 B

Time: 3 Hours

Max. Marks : 75 M

SECTION -A

Answer any FIVE questions, Each question carries 5 marks. 5x5=25

1. Explain the meaning, definition and origin of the Constitution. L1-Co1.
2. Write a note on Written and Unwritten Constitution. L1-Co1.
3. Write a note on "Cheques and Balance Theory". L5- Co2.
4. Explain the powers and functions of Unicameralism. L2- Co2.
5. Explain the Features of Unitary Government. L2-Co3 .
6. Explain the Merits of Presidential Government. L2- Co3
7. Explain the meaning, definition and importance of Democracy. L1-Co4
8. Explain the basic features of Direct Democracy . L2-Co4

SECTION -B

Answer all questions. Each question carries 10 marks

5x10=50

9. (a) Explain the meaning, definition and Evolution of the Constitution. L1,L5-
Co1
or
(b) Explain the Classifications of the Constitution. L2-Co1
10. (a) Critically examine the "Separation of the Power Theory". L1,L5-Co2
Or
(b) Explain the powers and functions of Bicameralism. L2-Co3
11. (a) Explain the basic features of the Federal Government.. L2, L4-Co3
(or)
(b) Explain the features of the Parliamentary Government. L2-Co3

12 . (a) Explain the merits and demerits of the Indirective Democracy. L4, L5-Co4
(or)

(b) Discuss the essential conditions for success of Democracy. L5-Co4.

13. (a) Explain the policies and programmes of Indian National Congress. LL2, L4-Co5
(or)

(b) Write an essay on Pressure Groups. L2,-Co5.

**A.G. & S.G.SIDDHARTHA DEGREE COLLEGE OF ARTS & SCIENCE
(AUTONOMOUS), (2021-2022) VUYYURU**

Course-4 : INDIAN POLITICAL PROCESS

IIInd YEAR

IV- SEMESTER

Course outcomes:

CO1: To demonstrate Legislative procedures which ensure the orderly conduct of business in our Parliament and state legislative assemblies in India.

CO2: To understand the election commission and functions.

CO3: To study the local government administration.

CO4: To understand the awareness of financial and government commissions

CO5: To understand the dynamics of Indian political system and awareness of voting importance in the society.

Learning Outcomes:

On successful completion of the course the students will be able to :

1. Know and understand the federal system of the country and some of the vital contemporary emerging issues. Evaluate the electoral system of the country and to identify the areas of electoral reforms.

2. Know the constitutional base and functioning of local governments with special emphasis on 73rd & 74th Constitutional Amendment Acts.

3. Understand the dynamics of Indian politics, challenges faced and gain a sensitive comprehension to the contributing factors.

4. Apply the knowledge and critically comprehend the functioning of some of the regulatory and governance institutions.

5. Propose theoretical outline alternate models

**A.G. & S.G.SIDDHARTHA DEGREE COLLEGE OF ARTS & SCIENCE
(AUTONOMOUS), (2021-2022) VUYYURU**

**Course-4 : INDIAN POLITICAL PROCESS
IInd YEAR IV- SEMESTER**

UNIT-I :	FEDERAL PROCESSES
	1. Features of Indian Federal System- Centre-State Relations- Legislative, Administrative and Financial
	2. Emerging Trends in Centre-State Relations-Restructuring Centre-State Relations-Recommendations of Sarkaria Commission, M.M.Punchi Commission. 15 hrs
UNIT-II :	ELECTORAL PROCESSES
	1. The Election Commission of India, Powers and Functions.
	2. Issues of Electoral Reforms, Voting Behaviour-Determinants and Problems of Defections. 15 hrs
UNIT-III :	GROSSROOT DEMOCRACY-DECENTRALISATION
	1. Panchayat Raj system-Local and Urban Governments-Structure, Powers and Functions.
	2. Democratic Decentralization-Rural Development and Poverty alleviation with reference to 73 rd and 74 th Constitutional Amendment Acts, Challenges and Prospects. 10 hrs
UNIT-IV :	SOCIAL DYNAMICS AND EMERGING CHALLENGES TO INDIAN POLITICAL SYSTEM
	1. Role of Caste, Religion, Language and Regionalism in India.
	2. Politics of Reservation, Criminalization of Politics and Internal threats to Security. 10 hrs
UNIT-V :	REGULATORY AND GOVERNANCE INSTITUTIONS
	1. NITI Ayog, Finance Commission, Comptroller and Auditor General of India.
	2. Central Vigilance Commission, Central Information Commission, Lokpal and Lokayukta. 10 hrs

REFERENCE BOOKS:

- D.D. Basu : An Introduction to the Constitution of India
- Rajni Kothari : Politics in India, Caste in Indian Politics
- Neelchosh : Indian Government and Politics
- Prof. Lalajah, P. Venkatarammam.

A.G. & S.G.SIDDHARTHA DEGREE COLLEGE OF ARTS & SCIENCE
(AUTONOMOUS), (2021-2022) VUYYURU
MODEL QUESTION PAPER (Semester-IV)

Time: 3 Hours

Max. Marks : 70M

SECTION -A

Answer any TWO of the following questions.:

2X5=10M.

1. Explain the features of Federal Government. CO1, L1
2. Explain the features of Local Governments. CO2
3. Discuss the Caste role in Indian political system. CO4, L5
4. Analyse the features of NITI Ayog.CO4, L4

SECTION -B

Answer any FOUR of the following questions.:

4x15=60

5. Discuss the Legislative, Administrative and Financial relations between the Central and State Government. CO1, L5
6. Explain the recommendations of Sarkariya Commission and M.M. Punchy Commission of Central-State government. CO1, L2
- 7.Explain the powers and functions of Election Commission. CO2, L2
8. Describe the determinants of voting behavior in India. CO2, L5
- 9..Explain the functions of Urban Government.CO3, L2
10. Discuss the basic features of Panchyati Raj in Andhra Pradesh. CO3, L5
11. Explain the the Religion and politics in India. Co4, L2
12. Write an essay on Central Legislative Council. CO5, L1

A.G. & S.G.SIDDHARTHA DEGREE COLLEGE OF ARTS & SCIENCE
(AUTONOMOUS), (2021-2022) VUYYURU

SECOND YEAR FOURTH SEMESTER

Course 5: WESTERN POLITICAL THOUGHT

Course outcomes :

CO1: It helps students discover the political philosophy that forms the basis of politics in the Western world, to interpret the political philosophies of the Greek, Roman, French, English and German philosophers in historical context as well as relate them to contemporary politics.

CO2: Origin of the knowledge in political thought.

CO3: To understand the political thoughts in medieval period and how it laid foundation to modern.

CO4: To demonstrate how government politics people by democracy and individual people.

CO5: To demonstrate individual freedom, surplus value, materialist.---

Learning outcomes:

On successful completion of the course the students will be able to:

1. Understand the fundamental contours classical, western political philosophy, basic features of medieval political thought and shift from medieval to modern era.
2. Understand the Social Contract Theory and appreciate its implications on the perception of State in terms of its purposes and role.
3. Acquaint with the Liberal and Marxist philosophy and analyze some trends in Western Political Thought.

3. critically analyse the evolution of western political thought.

**A.G. & S.G.SIDDHARTHA DEGREE COLLEGE OF ARTS & SCIENCE
(AUTONOMOUS), (2021-2022) VUYYURU**

SECOND YEAR FOURTH SEMESTER No.of Credits : 4 60 hours

Course 5: WESTERN POLITICAL THOUGHT

UNIT-I :	ANCIENT GREEK POLITICAL THOUGHT
	1. Plato-Rule of Philosopher Kings-Theory of Justice-Ideal State and Education 2. Aristotle-Theory of State-Classification of Governments-Citizenship, Slavery and Theory of Revolutions.
UNIT-II :	MEDIEVAL AND MODERN POLITICAL THOUGHT
	1. St. Augustine-Theory of Two Cities. 2. Niccolo Machiavelli-State and Statecraft.
UNIT-III :	CONTRACTUAL POLITICAL THOUGHT
	1. Thomas Hobbes- Social Contract and Absolute Sovereignty. 2. John Locke- Human Nature, State of Nature, Social Contract, Natural Rights and Limited Government 3. Jean Jacques Rousseau- Human Nature, State of Nature, Social Contract, General Will and Popular Sovereignty
UNIT-IV	UTILITARIAN POLITICAL THOUGHT
	1. Jermy Bentham-Theory of Utility, Law and Reforms. 2. J.S.Mill-Theory of Liberty and Representative Government.
UNIT-V :	MARXIST POLITICAL THOUGHT
	1. Karl Marx-Dialectical Materialism, Theory of Surplus Value and Class Struggle. 2. Antonio Gramsci-Hegemony and Civil Society.

REFERENCE BOOKS:

- O.P.Gauba : Western Political Thought
G.H.Sabine : A History of Political Theory E.Baker
Greek Political Theory : Plato and His

**A.G. & S.G.SIDDHARTHA DEGREE COLLEGE OF ARTS & SCIENCE
(AUTONOMOUS), (2021-2022) VUYYURU**

MODEL QUESTION PAPER (Semester-IV)

Time: 3 Hours

Marks :70m

SECTION- A

Answer any TWO of the following questions.:

2X5=10M.

1. Plato views on Philosopher Kings.CO1:
2. Explain Aristotle views on Classification of Governments. CO1,
3. St. Augustine views on 'City State'.CO2,
4. Natural Rights.

SECTION B

Answer any FOUR of the following questions.:

4x15=60

9. Critically examine Plato's views in 'Ideal State'.CO1, L5
10. Examine Aristotle views on Revolutions.CO1, L2
- 11.Critically examines the qualities of a Prince suggested by Machiavelli. CO2, L5
12. Discuss the 'Social Contract Theory ' of Thomas Hobbes. CO3, L5
13. "Man is born free but everywhere he is found in chains'. Explain. CO3, L2
14. Explain J.S. Mill contribution to the theory of Utilitarianism of Bentham. CO4, L3
15. Explain Bentham's theory of Pleasure and Pain.CO4, L2
16. Explain the features of Karl Marx Communism. CO5, L2

**AG & SG Siddhartha Degree College of Arts and Science (Autonomous),
Vuyyuru – 521 165.**

(An autonomous college in the jurisdiction of Krishna University, Machilipatnam, A.P)

Political Science	POJ, 6010E	2020-21	III BA
Semester-VI	Syllabus		Paper – VII C(Elective)

LOCAL SELF - GOVERNMENT IN ANDHRA PRADESH

Unit-I: Evolution of Local Self-Government in India

1. Constitutional Provisions on local Self-Government
2. Recommendations of Balwanthrai Mehta and Ashok Mehta Committees on Local Self – Government

Unit-II: Importance of Constitutional Amendments

1. 73rd Amendment – Rural Local bodies; Basic features
2. 74th Amendment – Urban Local bodies; Basic features

Unit-III: Structure and functions of Panchayati Raj in Andhra Pradesh

1. Gram Panchayat
2. Mandal Parishad
3. Zilla Parishad

Unit-IV: Structure and functions of urban local bodies in Andhra Pradesh

1. Nagar Panchayats
2. Municipalities
3. Municipal Corporations

Unit-V: Role of leadership and Emerging Challenges

1. Emerging patterns of leadership
2. Problems of autonomy: Financial and Administrative sphere

Reference Books:

1. Maheswari, S.R., Local Self Government in India, Orient longman, 1971
2. Venkatesan V, Institutionalising Panchayati Raj in India, Institute of Social Sciences, New Delhi 2002
3. Baviskar B.S, Inclusion and Excision in Local Governance, Sage Publication, New Delhi 2009.
4. M.P. Dube and Padalia, M (Ed), Democratic Decentralization and Panchayati raj in India, Anamika Publishers, New Delhi, 2002.
5. Bala Ramulu, CH and Ravinder D, "Five Decades of Democratic Decentralization process in Andhra Pradesh" in Social Change (Journal of the Council for Social Development published by Sage International) Vol.42, No.2, PP165-186, June 2012.

AG & SG Siddhartha Degree College of Arts and Science (Autonomous),

Vuyyuru - 521 165.

(An autonomous college in the jurisdiction of Krishna University, Machilipatnam, A.P)

POLITICAL SCIENCE	POL 601GE	2020-21	III BA
-------------------	-----------	---------	--------

Semester-VI

Paper -VII C(elective)

LOCAL SELF - GOVERNMENT IN ANDHRA PRADESH

Max.Marks: 70

Time: 3hrs

Guidelines to the paper setter

SECTION	Unit-I	Unit-II	Unit-III	Unit-IV	V
A 5 Marks Questions	1	1	1	1	
B 15 Marks Questions	2	1	2	2	1
Weightage	35	20	35	35	15

AG & SG Siddhartha Degree College of Arts and Science (Autonomous),

Vuyyuru – 521 165.

(An autonomous college in the jurisdiction of Krishna University, Machilipatnam, A.P)

Political Science	POL 602CE	2020-21	III BA
Semester-VI (Clusters)	Syllabus	Paper –VIII C1	

INTERNATIONAL RELATIONS

Unit-I: Basic Concepts of International Relations

1. Meaning, Nature and Scope of International Relations
2. (a). Balance of power (b). National interests (c). Collective Security
(d). Diplomacy

Unit-II: Approaches to the study of International Relations

1. Idealism – Woodrow Wilson
2. Classical Realism – Hans Morgenthau
3. Neo – realism – Kenneth Waltz

Unit-III: Phases of International Relations (1914-1945)

1. Causes for the First World War
2. Causes for the Second World War

Unit-IV: Phases of International Relations (1945 onwards)

1. Origins of First Cold War
2. Rise and Fall of Détente
3. Origins and the End of Second Cold War

Unit-V: International Organisation

1. The role of UNO in the protection of International Peace
2. Problems of the Third World : Struggle for New International Economic Order

Reference Books:

1. Jackson, R and Sorensan Y, Introduction to International Relations; Theories and approaches,

AG & SG Siddhartha Degree College of Arts and Science (Autonomous),

Vuyyuru - 521 165.

(An autonomous college in the jurisdiction of Krishna University, Machilipatnam, A.P)

POLITICAL SCIENCE	POL 602C1	2020-21	III BA
-------------------	-----------	---------	--------

Semester-VI

paper - VIII C1 (clusters)

INTERNATIONAL RELATIONS

Time: 3hrs

Max. marks: 70

Guidelines to the paper setter

SECTION	Unit-I	Unit-II	Unit-III	Unit-IV	V
A 5 Marks Questions	1	1	1	1	
B 15 Marks Questions	2	2	1	2	1
Weightage	35	35	20	35	15

Note: In view of vast syllabus more weightage given to unit-I

AG & SG Siddhartha Degree College of Arts and Science (Autonomous),

Vuyyuru – 521 165.

(An autonomous college in the jurisdiction of Krishna University, Machilipatnam, A.P)

Political Science	POL 603CE	2020-21	III BA
Semester-VI	Syllabus		Paper –VIII C2 (Clusters)

INDIAN FOREIGN POLICY

Unit-I: Evolution of Indian Foreign of Policy

1. Determinants of Indian Foreign of Policy
2. Continuity and change in Indian Foreign Policy

Unit-II: Non-Alignment and UNO

1. The role of India in the Non-Alignment Movement
2. Relevance of Non-Aligned Movement in the Contemporary World
3. Role of India in the UNO in protection of International Peace

Unit-III: India's Relation with USA and China

1. Indo- US Relations: Pre- Cold War Era, Post- Cold War Era
2. India – China Relations: Pre- Cold War Era, Post- Cold War Era

Unit-IV: India and her Neighbours

1. Indo- Pakistan Relations
2. India's role in South Asian Association of Regions Cooperation (SAARC)

Reference Books:

1. David Scott (Ed), Handbook of India's International Relations, London, Routledge,2011
2. Ganguly, S (Ed), India as an Emerging Power,Portland, Franck class, 2003
3. Pant, H, Contemporary Debates in Indian Foreign and Security Policy, London, Palgrave Macmillian,2008
4. Tellis, A and Mirski, S (Eds), Crux of Asia; China, India, and the Emerging global Order, Washington, Carnegie endowment for international peace,2013
5. Muni, S.D, India's Foreign Policy Delhi CUP, 2009
6. Alyssa Ayres and Raja Mohan, C (Eds), Power Realignment in Asia: China, India and the

United States, New Delhi, Sage, 2002

7. Appadorai, A, Domestic roots of Indian Foreign Policy, New Delhi, OUP,1971

AG & SG Siddhartha Degree College of Arts and Science (Autonomous),

Vuyyuru - 521 165.

(An autonomous college in the jurisdiction of Krishna University, Machilipatnam, A.P)

Political Science	POL. 603CE	2020-21	III BA
Semester-VI	Syllabus	Paper -VIII C2 (Cluster)	

INDIAN FOREIGN POLICY

Guidelines to the paper setter

SECTION	Unit-I	Unit-II	Unit-III	Unit-IV
A 5 Marks Questions	1	1	1	1
B 15 Marks Questions	2	2	2	2
Weightage	35	35	35	35

ఆంధ్ర ప్రదేశ్ విశ్వవిద్యాలయం
(An autonomous college in the jurisdiction of Andhra University, Machilipatnam, A.P.)

Political Science | POL SCIENCE | 2020-21 | III B.A.

Semester VI

Syllabus

Paper - VII C3 (Clusters)

GROUP PROJECT WORK

**A.G& S.G.SIDDHARTHA DEGREE COLLEGE OF ARTS &
SCIENCE**

VUYYURU-521165, KRISHNA Dt., A.P.(Autonomous)

Accredited by NAAC with "A" Grade

2021-2022



**DEPARTMENT OF TELUGU
MINUTES OF BOARD OF STUDIES
ODD SEMESTER**

30-10-2021

తెలుగు విభాగం పాఠ్య నిర్ణాయక మండలి (బోర్డు ఆఫ్ స్టడీస్) సమావేశం - 12

తేది.30-10-2021 ఉదయం 10 గంటలకు అడుసుమిల్లి గోపాలకృష్ణయ్య చెఱకు రైతుల సేద్యార్థ దీర్ఘ కళాశాల ఉయ్యూరులో, తెలుగు శాఖలో 2021 - 2022 విద్యా సంవత్సరానికి తెలుగు శాఖ అధ్యక్షురాలు శ్రీమతి ఎమ్.ఎల్.యస్. కుమారి అధ్యక్షతన సమావేశం నిర్వహించటం జరిగినది.

తెలుగు పాఠ్యాంశ నిర్ణాయక మండలి సమావేశానికి చర్చనీయాంశాలు.

1. 2021-2022 విద్యా సంవత్సరంలో ప్రథమ,ద్వితీయ బి.ఎ., బి.కాం., బి.యస్.సి తరగతులకు మొదటి, మూడవ సెమిస్టర్లకు సంబంధించిన పాఠ్యాంశాల నిర్ణయం గురించి.
2. తెలుగు శాఖ ఆధ్వర్యంలో జర్నలిజం సర్టిఫికేట్ కోర్సు నిర్వహించడం గురించి.
3. అధ్యక్షురాలు అనుమతితో ఇతర అంశాలు ఏమైనా.....

తీర్మానాలు:

తేది.30-10-2021 ఉదయం 10 గంటలకు అడుసుమిల్లి గోపాలకృష్ణయ్య చెఱకు రైతుల సేద్యార్థ దీర్ఘ కళాశాల ఉయ్యూరులో 2021 -2022 విద్యా సంవత్సరానికి రెండవ భాషగా తెలుగు పాఠ్యాంశాలు నిర్ణయించిన తరువాత తెలుగు పాఠ్య నిర్ణాయక మండలి (బోర్డు ఆఫ్ స్టడీస్) సభ్యులు ఈ క్రింది తీర్మానాలను ఏకగ్రీవంగా ఆమోదించడమైనది.

1. 2021 -2022 విద్యా సంవత్సరం ప్రథమ బి.ఎ., బి.కాం., బి.యస్.సి తరగతులకి మొదటి సెమిస్టర్ సీలబస్ లో ఉన్న 'పలనాటి టెబ్బులి' అనే పాఠాన్ని తీసివేసి దానికి బదులుగా 'మధుర స్నేహం' అనే పాఠాన్ని చేర్చాలని తీర్మానించడమైనది.
2. మూడవ సెమిస్టర్ ఆంధ్ర ప్రదేశ్ స్టేట్ కౌన్సిల్ ఆఫ్ హైయర్ ఎడ్యుకేషన్ (APSCHE) వారు పెట్టిన సీలబస్ ని యథాతథంగా కొనసాగించాలని తీర్మానించడమైనది.
3. 2021 -2022 విద్యా సంవత్సరం ప్రథమ బి.ఎ., బి.కాం., బి.ఎస్.సి ప్రశ్న పత్రం ఎక్స్ టర్నల్ 75 మార్కులకు, ఇంటర్నల్ 25 మార్కులకు ఇవ్వాలని, ద్వితీయ బి.ఎ., బి.కాం., బి.ఎస్.సి మూడవ సెమిస్టరుకు ప్రశ్న పత్రం ఎక్స్ టర్నల్ 70 మార్కులకు, ఇంటర్నల్ 30 మార్కులకు ఇవ్వాలని తీర్మానించడమైనది.
4. 2021 -2022 విద్యా సంవత్సరం ప్రథమ, ద్వితీయ బి.ఎ.,బి.కాం., బి.ఎస్.సి విద్యార్థులకు కనీస పాస్ మార్కులు లేవని తీర్మానించడమైనది.
5. తెలుగు శాఖ ఆధ్వర్యంలో జర్నలిజం సర్టిఫికేట్ కోర్సు నిర్వహించాలని తీర్మానించడమైనది.

హాజరైన సభ్యులు:-

1. శ్రీమతి ఎమ్.ఎల్.యస్ కుమారి M.L.S. Kumari
తెలుగు శాఖ అధ్యక్షురాలు, పాఠ్య నిర్ణాయక మండలి అధ్యక్షులు.

2. శ్రీమతి ఎమ్. రమాదేవి M. Rama Devi
తెలుగు అధ్యాపకురాలు

3. శ్రీమతి బి.ఎస్.ఎల్ పద్మశ్రీ B.S.L. Padmasri
తెలుగు శాఖ అధ్యక్షురాలు,
ఎస్.పి మహిళా కళాశాల,
మచిలీపట్నం.
(కృష్ణా విశ్వవిద్యాలయం నామిని)

4. డా|| వై. పూర్ణచంద్ర రావు
తెలుగు శాఖ అధ్యక్షులు
అ.ప్రో,
పి.బి సిద్ధార్థ కళాశాల,
విజయవాడ - 10
విషయ నిపుణులు (Subject Expert)

6. డా|| జి. శ్రీనివాస్, G. Sri - n
తెలుగు శాఖ అధ్యక్షులు,
ప్రభుత్వ డిగ్రీ కళాశాల,
చింతలపూడి.
విషయ నిపుణులు (Subject Expert)

7. కుమారి పి. కాశీ విశ్వేశ్వరి P. Kasi Vishweswari
విద్యార్థి ప్రతినిధి.

TELUGU	TELTHA	2021-2022	IB.A.,B.COM.,B.SC
--------	--------	-----------	-------------------

I SEMESTER – SYLLABUS
TELUGU - I

యూనిట్ - I

రాజనీతి - నన్నయ

మహా భారతం - సభాపర్వం - ప్రథమాశ్వాసంలో 26వ పద్యము “మీవంశమున - నీవు వారిదైన నేర్పటింగి” నుండి 57వ పద్యము “నాయథాకృతివాని ననుష్ఠితు బ్రియముతోడ” వరకు.

యూనిట్ - II

దక్షయజ్ఞం - నన్నెచోడుడు

కుమార సంభవం - ద్వితీయాశ్వాసంలో 49వ వచనం “అంతకమున్ను.....భయంకరా కారంబుదాల్పిన” నుండి 86వ పద్యం “ప్రమదగణము.....కనిరిశంభు” వరకు.

యూనిట్ - III

దౌమ్యధర్మోపదేశము - తిక్కన

మహాభారతము - విరాటపర్వము - ప్రథమాశ్వాసంలో 116వ పద్యం “ఎఱిగెడు వారికినైనను.... వలయు దగియెడు బుద్ధుల్” నుండి 146వ పద్యం “అతడు నియతితోడ....సంచయములు దగ జపించుచుండె” వరకు

యూనిట్ - IV

మదుర స్నేహం - పోతన

ఆంధ్రమహాభాగవతము - దశమస్కంధము - కుచేలోపాఖ్యానంలో 962వ పద్యం “లలిత పతివ్రతా తిలకంబు.....కుపాయమూహింప వైతి” నుండి 983వ పద్యం “తన మృదుతల్పమందు.....ధరణీసురు డెందటి భాగ్యవంతుడో” వరకు.

యూనిట్ - V

సీతారావణ సంవాదం - మొల్ల

రామాయణము - సుందరకాండములో 40వ వచనం “ఆరామంజుచి....వృక్షం బారోహించి యుండు” నుండి 87వ పద్యం “కావున నిక్కోమలియెడ....మనకు దిక్కగు మీదన్” వరకు.

వ్యాకరణము :-

1. సంధులు :- సవర్ణ, గుణ, యణాదేశ,వృద్ధి, అకార,ఇకార,ఉకార,త్రికనంధులు

2. సమాసములు :- తత్పురుష, కర్మీదారయ, ద్వంద్వ, ద్విగు, బహువ్రీహి సమాసములు.

3. ధందస్సు :- వృత్తి పద్యాలలో ఉత్పలమాల,చంపకమాల,శార్దూలము, మల్లేభము.

జాతులు, ఉపజాతుల్లో కందము, తేటగీతి, ఆటవెలది మరియు ముత్యాలసరాలు.

4. అలంకారములు :- శబ్దాలంకారాల్లో అనుప్రాసలైన వృత్తి,నుప్రాస, చేకానుప్రాస,లాటానుప్రాస, అంత్యానుప్రాసములు.

అర్థాలంకారాల్లో ఉపమ,ఉత్పేక్ష,రూపక క్షేపలు.

ఆధార గ్రంథాలు:

1. శ్రీ మదాంధ్ర మహాభారతము - సభా పర్వము - తిరుమల తిరుపతి దేవస్థానం ప్రచురణ.
2. శ్రీ మదాంధ్ర మహాభారతము - విరాట పర్వము - తిరుమల తిరుపతి దేవస్థానం ప్రచురణ.
3. కుమార సంభవం - నన్నె చోడుడు.
4. శ్రీ మహాభాగవతము - పోతన
5. రామాయణము - మొల్ల.

TELUGU	TELTHIA	2021 - 2022	I B.A., B.Com., B.Sc.
I SEMESTER - MODEL PAPER			

ప్రాచీన కవిత్వం , ఆధునిక కవిత్వం, కథానికలు, వ్యాకరణం

పార్టు - ఎ

1. ఈ క్రింది వానిలో ఒక దానికి ప్రతి పదార్థ తాత్పర్యమును వ్రాయండి.

7మా

ఎ. బహుదనదాన్య సంగ్రహము బాణశరాసన యోధవీర సం
గ్రహము నిరంతరాంతరుదకంబులు ఘోసరసింధనౌఘ సం
గ్రహము ననేక యంత్రములు గల్గి యసాధ్యములై ద్విషద్యయా
వహు లగుచుండ నొప్పునె భవత్పరి రక్ష్యములైన దుర్గముల్.

లేదా

బి. కలలోనందను మున్నెఱుంగని మహా కష్టాత్ముడై నట్టి దు
ర్బలు డాపత్యమయంబునన్ నిజ పదాబ్జాతంబులు ల్లంబులోన్
దలపన్నంతనె మెచ్చి యార్త హరుడై తనైనన నిచ్చున్ సు ని
శ్చల భక్తిన్ భజియించువారి కిడడే సంపద్విశిషోన్నతుల్.

II. క్రింది వానిలో మూడింటికి సందర్భసహిత వ్యాఖ్యలు వ్రాయండి.

3 X 4 = 12మా

1. వార్త నిర్వహింపవలయు బతికి.
2. నన్ను బనుపు దక్షు బట్టి తెచ్చెదన్
3. పురుషార్థంబునకు హాని పుట్టుక యున్న?
4. గోవింద దర్శనోత్సాహి యగుచు.
5. ఉండుటిది న్యాయమే లతాంగి!

III. క్రింది వానిలో మూడింటికి సంగ్రహరూప సమాధానాలు వ్రాయండి.

3 X 4 = 12మా

1. రాజు చేయకూడని పనుల్ని తెల్పండి ?
2. ప్రమథులు దక్షుని బంధించిన తీరును తెల్పండి ?
3. దౌమ్ముని ఉపదేశానంతరం ఏమి జరిగింది ?
4. అంతఃపురకాంతలు కుచేలుని గూర్చి భావించిన విషయాల్ని తెల్పండి ?
5. త్రిజట తన స్వప్నాన్ని ఏమని వివరించెను ?

IV. క్రింది వానిలో మూడింటికి వ్యాసరూప సమాధానాలు వ్రాయండి.

3 X 8 = 24మా

1. ప్రజా పాలనలో రాజులు పాటించాల్సిన ధర్మాలేవి
2. దక్షయజ్ఞం సారాంశాన్ని వ్రాయండి.
3. దొమ్ముడు పాండవులకు చేసిన ధర్మోపదేశాన్ని వివరించండి.
4. మధురస్నేహం పాఠ్య సారాంశాన్ని తెల్పండి.
5. సీతారావణ సంవాదాన్ని వివరించండి.

V. క్రింది వానిలో మూడింటిని విడదీసి, సంది కార్యము వ్రాయండి.

3 X 2 = 6మా

1. శత్రైకవృద్ధి
2. జగమెల్ల
3. మనుజేంద్రుడు
4. కష్టాత్ముడు
5. ఇక్కోమల్లి

VI. క్రింది వానిలో మూడింటికి విగ్రహ వాక్యాలు వ్రాసి, సమాస నామములు తెల్పండి

3 X 2 = 6మా

1. అష్టాంగాలు
2. ఆశ్రమము
3. భీమార్జునులు
4. మధురస్నేహం
5. తోయజాక్షి

VII. క్రింది పద్య పాదాన్ని గణ విభజన చేసి, యతిని గుర్తించి ఏ పద్య పాదమో తెల్పండి

1 x 4 = 4మా

తన మృదుతల్పమందు వనితామణియైన రమాలలామ పొం

లేదా

క్రింది వానిలో ఒక దానికి లక్ష్య, లక్షణ సమన్వయం చేయండి

1. తేటగీతి
2. ముత్యాలసరాలు
3. ఆటవెలది

VIII. క్రింది పద్యంలోని అలంకారమును గుర్తించి, లక్ష్య లక్షణ సమన్వయం చేయండి.

1 x 4 = 4మా

'బాల సఖుడైన యప్పద్మ పత్రనేత్ర

గాన నేగి దరిద్రాంధకార మగు

లయిన మము నుద్ధరింపుము హరి కృపాక

టాక రవిదీప్తి వడసి మహాత్మ! నీవు.

లేదా

క్రింది వానిలో ఒకదానికి లక్ష్య లక్షణ సమన్వయం చేయండి.

1. వృత్తాను ప్రాసము
2. ఉపమాలంకారము

ACCREDITED AT 'A' NACC
I Year B.A., B.Com., B.SC.,
Telugu I SEMESTER
Guidelines to paper Setters

ప్రశ్న పత్ర నిర్మాణ సూచిక

TELUGU - I

1. ప్రతి పదార్థ పద్యాలు:	2-1	1x7 = 7మా	2. సందర్భ సహిత వ్యాఖ్యలు:	5-3	3x4 = 12మా
3. సంగ్రహ రూప ప్రశ్నలు:	5-3	3x4 = 12మా	4. వ్యాస రూప ప్రశ్నలు:	5-3	3x8 = 24మా
5. సంధులు:	5-3	3x2 = 6మా	6. సమాసములు:	5-3	3x2 = 6మా
7. ఛందస్సు:	2-1	1x4 = 4మా	8. అలంకారములు:	2-1	1x4 = 4మా
					మొత్తం = 75 మా

గమనికలు - సూచనలు

1. ప్రతి పదార్థ పద్యాలు:- " రాజనీతి, దోమ్య దర్మోపదేశం, మదుర స్నేహం" అనే మూడు పాఠాల నుండి రెండు పద్యాలు ఇవ్వాలి. అవి కూడా ఈ క్రింది పద్యాలలో నుండి రెండు ఇవ్వాలి.

రాజనీతి:

1. ఉత్తమ మధ్యమాధమ.....కాలము దప్పుకుండగన్.
2. బహు ధనదాన్య సంగ్రహము.....భవత్పరి రక్ష్యములైన దుర్గముల్.

దోమ్య దర్మోపదేశము:

3. రాజ గృహంబు కంటి.....దగదట్లు సేయగన్.
4. దరణిపు దక్క..... న్గుండుట నీతి కొలువునన్.

మదుర స్నేహం:

5. కలలోనందను.....సంపద్విశిష్టతుల్.
6. కనిదాయంబనునంత.....విలోలుండై దిగెన్ తల్పమున.

2. సందర్భ సహిత వ్యాఖ్యలు:- " రాజనీతి, దక్షయజ్ఞం, దోమ్య దర్మోపదేశం, మదుర స్నేహం, సీతారావణ సంవాదం" అనే ఐదు పాఠాల నుండి ఒక్కొక్కటి చొప్పున ఒక్కో పాఠము నుండి ఒక సందర్భ సహిత వ్యాఖ్య ఇవ్వాలి.

3. సంగ్రహ రూప ప్రశ్నలు:- " రాజనీతి, దక్షయజ్ఞం, దోమ్య దర్మోపదేశం, మదుర స్నేహం, సీతారావణ సంవాదం" అనే ఐదు పాఠాల నుండి ఒక్కొక్కటి చొప్పున ఒక్కో పాఠము నుండి సంగ్రహ రూప ప్రశ్న ఇవ్వాలి.

4. వ్యాస రూప ప్రశ్నలు:- "రాజనీతి దక్షయజ్ఞం, దోమ్య దర్మోపదేశం, మదుర స్నేహం, సీతారావణ సంవాదం" అనే ఐదు పాఠాల నుండి ఒక్కొక్కటి చొప్పున ఒక్కో పాఠం నుండి వ్యాస రూప ప్రశ్న ఇవ్వాలి.

5. సంధులు:- "సవర్ణ, గుణ, యణాదేశి, వృద్ధి, అకార, ఇకార, ఉకార, త్రిక సంధు" ల నుండి ఐదు సంధులు ఇవ్వాలి.

6. సమాసములు:- "తత్పురుష, కర్మధారయ, ద్వంద్వ, ద్వగు, బహువ్రీహి సమాసము" ల నుండి ఐదు సమాసములు ఇవ్వాలి.

7. ఛందస్సు:- వృత్తపద్యాలైన " ఉత్పలమాల, చంపకమాల, శార్దూలము, మత్తేభము" ల నుండి ఒక పద్యపాదమును ఇవ్వాలి. జాతులు, ఉపజాతుల పద్యాలైన "కందము, తేటగీతి, ఆటవెలది" మరియు 'ముత్యాలసరాలు' నుండి ఏదైనా మూడిచ్చి ఒకదానిని లక్ష్యలక్షణ సమన్వయం చేయమనాలి.

8. అలంకారములు:- అర్థాలంకారాలైన "ఉపమ, ఉత్పేక్ష, రూపకము, శ్లేష" ల నుండి ఒక అలంకారము ఇవ్వాలి. అది కూడా ఐదు పాఠాల (రాజనీతి, దక్షయజ్ఞం, దోమ్యదర్మోపదేశము, మదురస్నేహం, సీతారావణ సంవాదం) నుండి ఒక పద్యాన్ని ఇవ్వాలి.

శబ్దాలంకారాల నుండి "వృత్త్యనుప్రాస, చేకానుప్రాస, లాటానుప్రాస, అంత్యానుప్రాస" ల నుండి రెండు అలంకారములను ఇచ్చి, ఒక అలంకారము వ్రాయమనాలి.

ఇక నమూనా ప్రశ్నపత్రాన్ని పరిశీలించి తరువాత ప్రశ్నపత్రాన్ని తయారు చేసుకోవాలి.

(An Autonomous College in the jurisdiction of Krishna University, Machilipatnam, A.P.India

Accredited at 'A' NACC
TELUGU TEL – 301 2021-2022

IB.A.,B.COM.,B.SC

III SEMESTER – SYLLABUS
TELUGU – I

పాఠ్య ప్రణాళిక

యూనిట్ - 1: వ్యక్తికరణ నైపుణ్యాలు

1. భాష - ప్రాథమికాంశాలు: భాష నిర్వచనం, లక్షణాలు, ఆవశ్యకత, ప్రయోజనాలు.
2. వర్ణం - పదం-వాక్యం: వాక్య లక్షణాలు, సామాన్య, సంయుక్త, సంశ్లేష్ట వాక్యాలు.
3. భాష నిర్మాణంలో 'వర్ణం-పదం-వాక్యం' ప్రాధాన్యత.

యూనిట్ -II : సృజనాత్మక రచన

4. కవితా రచన : ఉత్తమ కవిత - లక్షణాలు
5. కథారచన : ఉత్తమ కథ - లక్షణాలు
6. వ్యాస రచన : ఉత్తమ వ్యాసం - లక్షణాలు

యూనిట్ - III : అనువాద రచన

7. అనువాదం - నిర్వచనం, అనువాద పద్ధతులు.
8. అనువాద సమస్యలు - భౌగోళిక, భాషా, సాంస్కృతిక సమస్యలు, పరిష్కారాలు.
9. అభ్యాసము : ఆంగ్లం నుండి తెలుగుకు అనువదించడం.

యూనిట్ - IV : మాధ్యమాలకు రచన - 1 (ముద్రణా మాధ్యమం/ప్రింటు మీడియా)

10. ముద్రణా మాధ్యమం (అచ్చు మాధ్యమం): పరిచయం, పరిధి, వికాసం.
11. వివిధ రకాల పత్రికలు - పరిశీలన, పత్రికాభాష, శైలి, వైవిధ్యం.
12. పత్రికా రచన : వార్తా రచన, సంపాదకీయాలు, సమీక్షలు - అవగాహన.

యూనిట్ - V : మాధ్యమాలకు రచన - 2 (ప్రసార మాధ్యమం/ఎలక్ట్రానిక్ మీడియా)

13. ప్రసార మాధ్యమాలు : నిర్వచనం, రకాలు, విస్తృతి, ప్రయోజనాలు
14. శ్రవణ మాధ్యమాలు - రచన : రేడియో రచన, ప్రసంగాలు, నాటికలు, ప్రసార సమాచారం.
15. దృశ్య మాధ్యమాలు - రచన : వ్యాఖ్యానం (యాంకరింగ్), టెలివిజన్ రచన

III SEMESTER – SYLLABUS
TELUGU – I

పాఠ్య ప్రణాళిక

యూనిట్ - 1: వ్యక్తీకరణ నైపుణ్యాలు

1. భాష - ప్రాథమికాంశాలు: భాష నిర్వచనం, లక్షణాలు, ఆవశ్యకత, ప్రయోజనాలు.
2. వర్ణం - పదం-వాక్యం: వాక్య లక్షణాలు, సామాన్య, సంయుక్త, సంశ్లేష్ట వాక్యాలు.
3. భాష నిర్మాణంలో 'వర్ణం-పదం-వాక్యం' ప్రాధాన్యత.

యూనిట్ -II : సృజనాత్మక రచన

4. కవితా రచన : ఉత్తమ కవిత - లక్షణాలు
5. కథారచన : ఉత్తమ కథ - లక్షణాలు
6. వ్యాస రచన : ఉత్తమ వ్యాసం - లక్షణాలు

యూనిట్ - III : అనువాద రచన

7. అనువాదం - నిర్వచనం, అనువాద పద్ధతులు.
8. అనువాద సమస్యలు - భాగోళిక, భాషా, సాంస్కృతిక సమస్యలు, పరిష్కారాలు.
9. అభ్యాసము : ఆంగ్లం నుండి తెలుగుకు అనువదించడం.

యూనిట్ - IV : మాధ్యమాలకు రచన - 1 (ముద్రణా మాధ్యమం/ప్రింటు మీడియా)

10. ముద్రణా మాధ్యమం (అచ్చు మాధ్యమం): పరిచయం, పరిధి, వికాసం.
11. వివిధ రకాల పత్రికలు - పరిశీలన, పత్రికాభాష, శైలి, వైవిధ్యం.
12. పత్రికా రచన : వార్తా రచన, సంపాదకీయాలు, సమీక్షలు - అవగాహన.

యూనిట్ - V : మాధ్యమాలకు రచన - 2 (ప్రసార మాధ్యమం/ఎలక్ట్రానిక్ మీడియా)

13. ప్రసార మాధ్యమాలు : నిర్వచనం, రకాలు, విస్తృతి, ప్రయోజనాలు
14. శ్రవణ మాధ్యమాలు - రచన : రేడియో రచన, ప్రసంగాలు, నాటికలు, ప్రసార సమాచారం.
15. దృశ్య మాధ్యమాలు - రచన : వ్యాఖ్యానం (యాంకరింగ్), టెలివిజన్ రచన

TELUGU

I B.A., B.Com., B.Sc.

మాదిరి ప్రశ్నాపత్రం

పార్ట్ - ఎ

క్రింది వానిలో ఐదంటికి సంక్షిప్త సమాధానాలు రాయండి.

5 X 4 = 20మా

- | | |
|---|---------------------|
| 1. భాష - ప్రయోజనాలు | 2. వాక్యం-లక్షణాలు |
| 3. టెలివిజన్ రచన | 4. రేడియో రచన |
| 5. ఉత్తమ వ్యాసం-లక్షణాలు | 6. సంశ్లేష్ట వాక్యం |
| 7. సంపాదకీయాలు | 8. మాండలికాలు |
| 9.వార్తా రచన | |
| 10. క్రింది అంశాన్ని తెలుగులోకి అనువదించి రాయండి. | |

To many, Indian thought, Indian manners, Indian customs, Indian philosophy, Indian Literature are repulsive at the first site; but let them preserve, let them read, let them become familiar with the great principles underlying these Ideas, and it is ninety – nine to one that the charm will come over them, and fascination will be the result. Slow and silent, as the gentle dew that falls in the morning, un seen and unheard yet producing, a most tremendous result, has been the work of the calm, patient, all suffering spiritual race up on the old of thought.

పార్ట్ - బి

క్రింది వానిలో ఐదు ప్రశ్నలకు వ్యాసరూప సమాధానాలు రాయండి.

5 X 10 = 50మా

11. భాషా నిర్మాణంలో వర్ణం, పదం, వాక్యాల ప్రాధాన్యతను వివరించండి.
12. భాషను నిర్వచించి, లక్షణాలు రాసి, ప్రామాణిక భాషను పరిచయం చేయండి.
13. ఉత్తమ కవితా లక్షణాలను విశ్లేషించండి.
14. ఉత్తమ కథా లక్షణాలను వివరించండి.
15. అనువాద సమస్యలను, వ్యాటి పరిష్కారాలను గూర్చి రాయండి.
16. అనువాద లక్షణాలను వివరిస్తూ అనువాద పద్ధతులను గూర్చి రాయండి.
17. ముద్రణా మాధ్యమాన్ని పరిచయం చేస్తూ దాని పరిధి, వికాసాలను వివరించండి.
18. పత్రికా రచనను గురించి విశ్లేషణాత్మక వ్యాసం రాయండి.
19. ప్రసార మాధ్యమాల విస్తృతి, ప్రయోజనాలను సమీక్షించండి.
20. యాంకరింగ్ నిర్వహణ తీరు తెన్నులను వివరించండి.

A.G & S.G. Siddhartha Degree College Of Arts & Science
Vuyyuru – 521 165, Krishna Dist.
(An Autonomous College in the jurisdiction of Krishna University, Machilipatnam, A.P.,India)
ACCREDITED AT 'A' NACC
I Year B.A., B.Com., B.SC.,
Telugu III SEMESTER
Guidelines to paper Setters

పార్ట్ - ఎ

1వ ప్రశ్నలో సంక్షిప్త సమాధానాలు :

యానిట్ - 1 నుండి రెండు ప్రశ్నలు
యానిట్ - 2 నుండి రెండు ప్రశ్నలు
యానిట్ - 3 నుండి రెండు ప్రశ్నలు
యానిట్ - 4 నుండి రెండు ప్రశ్నలు
యానిట్ - 5 నుండి రెండు ప్రశ్నలు
మొత్తం 10 ప్రశ్నలు ఇవ్వవలెను.

పార్ట్ - బి

2వ ప్రశ్నలో పెద్ద సమాధానాలు :

యానిట్ - 1 నుండి రెండు ప్రశ్నలు
యానిట్ - 2 నుండి రెండు ప్రశ్నలు
యానిట్ - 3 నుండి రెండు ప్రశ్నలు
యానిట్ - 4 నుండి రెండు ప్రశ్నలు
యానిట్ - 5 నుండి రెండు ప్రశ్నలు
మొత్తం 10 ప్రశ్నలు ఇవ్వవలెను.

-----*-----

**A.G& S.G.SIDDHARTHA DEGREE COLLEGE OF ARTS &
SCIENCE**

VUYYURU-521165, KRISHNA Dt., A.P.(Autonomous)

Accredited by NAAC with "A" Grade

2021-2022



**DEPARTMENT OF TELUGU
MINUTES OF BOARD OF STUDIES**

EVEN SEMESTER

06-04-2022

తెలుగు విభాగం పాఠ్య నిర్ణాయక మండలి (బోర్డు ఆఫ్ స్టడీస్) సమావేశం - 13

తేది.06-04-2022 ఉదయం 10 గంటలకు అడుసుమిల్లి గోపాలకృష్ణయ్య చెఱుకు రైతుల సిద్ధార్థ డిగ్రీ కళాశాల ఉయ్యూరు, తెలుగు శాఖలో 2022 - 2023 విద్యా సంవత్సరానికి తెలుగు శాఖ అధ్యక్షురాలు శ్రీమతి ఎమ్.ఎల్.యస్. కుమారి అధ్యక్షతన సమావేశం నిర్వహించటం జరిగినది.

తెలుగు పాఠ్యాంశ నిర్ణాయక మండలి సమావేశానికి చర్చనీయాంశాలు.

1. 2022-2023 విద్యా సంవత్సరంలో మొదటి బి.ఎ., బి.కాం., బి.ఎస్.సి తరగతులకు రెండవ సెమిస్టరుకు సంబంధించిన పాఠ్యాంశాల నిర్ణయం గురించి.
2. అధ్యక్షురాలు అనుమతితో ఇతర అంశాలు ఏమైనా.....

తీర్మానాలు:

తేది.06-04-2022 ఉదయం 10 గంటలకు అడుసుమిల్లి గోపాలకృష్ణయ్య చెఱుకు రైతుల సిద్ధార్థ డిగ్రీ కళాశాల ఉయ్యూరులో 2022 -2023 విద్యా సంవత్సరానికి రెండవ భాషగా తెలుగు పాఠ్యాంశాలు నిర్ణయించిన తరువాత తెలుగు పాఠ్య నిర్ణాయక మండలి (బోర్డు ఆఫ్ స్టడీస్) సభ్యులు ఈ క్రింది తీర్మానాలను ఏకగ్రీవంగా ఆమోదించడమైనది.

1. 2022 -2023 విద్యా సంవత్సరం మొదటి బి.ఎ., బి.కాం., బి.ఎస్.సి తరగతులకి రెండవ సెమిస్టర్ సెలబ్షన్ లో ఉన్న 'తాతకో నూలుపోగు' అనే పాఠాన్ని తీసివేసి దానికి బదులుగా 'కన్యక' అనే పాఠాన్ని చేర్చాలని తీర్మానించడమైనది.
2. 2022-2023 విద్యా సంవత్సరం మొదటి బి.ఎ., బి.కాం., బి.ఎస్.సి రెండవ సెమిస్టర్ ప్రశ్న పత్రం ఎక్స్ టర్నల్ 75 మార్కులకు, ఇంటర్నల్ 25 మార్కులకు ఇవ్వాలని తీర్మానించడమైనది.
3. 2022 -2023 విద్యా సంవత్సరం మొదటి బి.ఎ.,బి.కాం., బి.ఎస్.సి విద్యార్థులకు కనీస పాస్ మార్కులు లేవని తీర్మానించడమైనది.

హాజరైన సభ్యులు:-

1. శ్రీమతి ఎమ్.ఎల్.యస్ కుమారి, *M. L. S. - Kumari*
తెలుగు శాఖ అధ్యక్షురాలు, పాఠ్య నిర్ణాయక మండలి అధ్యక్షులు.

2. శ్రీమతి బి.ఎస్.ఎల్ పద్మశ్రీ,
నామిని, కృష్ణా విశ్వవిద్యాలయం,
తెలుగు అధ్యాపకురాలు,
ఎస్.సి.ఐ.ఎమ్ గవర్నమెంట్ డిగ్రీ కళాశాల,
తణుకు, ప.గో.జి.

B. SL Padma Sri

3. డా॥ వై. పూర్ణచంద్ర రావు,
తెలుగు శాఖ అధ్యక్షులు
అ.ప్రో,



పి.బి సిద్ధార్థ కళాశాల,
విజయవాడ - 10

విషయ నిపుణులు (Subject Expert)

4. డా॥ జి. శ్రీనివాస్,
తెలుగు శాఖ అధ్యక్షులు,
ప్రభుత్వ డిగ్రీ కళాశాల,
చింతలపూడి.

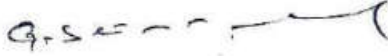

విషయ నిపుణులు (Subject Expert)

5. శ్రీమతి ఎమ్.రమాదేవి,
తెలుగు అధ్యాపకురాలు

ఎమ్. రమాదేవి

6. శ్రీమతి జి.జ్యోతి, *జి. Jyothi*
తెలుగు అధ్యాపకురాలు

7. కుమారి పి. కాళీ విశ్వకర్మ, *P. Kalya Vishwakarma*
విద్యార్థి ప్రతినిధి.

AG & SG SIDDHARTHA DEGREE COLLEGE OF ARTS AND SCIENCE, VUYURU – 521 165, Krishna District
(An autonomous college in the jurisdiction of Krishna University, Machilipatnam, A.P India
Accredited at 'A' NACC

Telugu - II
పాఠ్య ప్రణాళిక

యూనిట్ - I

1. ఆధునిక కవిత్వం - పరిచయం
2. కన్యక - గురజాడ వేంకట అప్పారావు
3. కొండవీడు - దువ్వూరి రామిరెడ్డి (కవి కోకిల గ్రంథావళి - ఖండకావ్యాలు - నక్షత్రాల సంపుటి నుండి)
4. మాత్య సంగీతం - అనిసెట్టి సుబ్బారావు (అగ్ని వీణ కవితా సంపుటి నుండి)

యూనిట్ - II

5. తెలుగు కథానిక - పరిచయం
6. భయం / కథ / కాళీపట్నం రామారావు
7. స్వేదం ఖరీదు ? / కథ / - రెంటాల నాగేశ్వరరావు

యూనిట్ - III

8. తెలుగు 'నవల' - పరిచయం
9. రథచక్రాలు / నవల / - మహీధర రామ్మోహనరావు (సంక్షిప్త ఇతివృత్తం మాత్రమే)
10. రథచక్రాలు / సమీక్షా వ్యాసం / - డా. యల్లాప్రగడ మల్లికార్జున రావు

యూనిట్ - IV

11. తెలుగు నాటకం - పరిచయం
12. యక్షగానము / నాటకము / నాటిక / - ఎం.ఎం.వి.ఎస్. హరనాథ రావు
13. అపురూప కళారూపాల విధ్వంసక దృశ్యం 'యక్షగానము' / సమీక్షా వ్యాసం - డా. కందిమళ్ళ సాంబశివరావు

యూనిట్ - V

14. తెలుగు సాహిత్య విమర్శ - పరిచయం
15. విమర్శ - స్వరూప స్వభావాలు, ఉత్తమ విమర్శకుడు - లక్షణాలు

ఆకార గ్రంథాలు / వ్యాసాలు

1. ఆధునిక కవిత్వం - పరిచయం - ప్రో. ఎస్ వి సత్యనారాయణ
2. తెలుగు కథానిక - పరిచయం - ప్రో. రాచపాళేం చంద్రశేఖర్ రెడ్డి
3. తెలుగు నవల - పరిచయం - వల్లంపాటి వెంకటసుబ్బయ్య
4. సాంఘిక నవల - కథన శిల్పం - ప్రో. సి. మృణాళిని
5. తెలుగు నాటకం - పరిచయం - ప్రో. ఎస్ గంగప్ప
6. తెలుగు సాహిత్య విమర్శ - పరిచయం - ప్రో. జి. వి. సుబ్రహ్మణ్యం
7. నూరేళ్ల తెలుగు నాటక రంగం - ప్రో. మొదలి నాగభూషణ శర్మ
8. నాటక శిల్పం - ప్రో. మొదలి నాగభూషణ శర్మ

TELUGU – II

ప్రశ్న పత్రం నిర్మాణ సూచిక:

1. సంక్షిప్త రూప ప్రశ్నలు :

4 X 5 = 20మా

ప్రతి యూనిట్ నుండి తప్పనిసరిగా ఒక ప్రశ్న ఇచ్చి, మొత్తం మీద ఎనిమిది ప్రశ్నలు ఇవ్వాలి. అందులో ఐదింటికి సమాధానాలు వ్రాయమనాలి.

2. వ్యాసరూప ప్రశ్నలు :

5 x 10 = 50మా

ప్రతి యూనిట్ నుండి తప్పనిసరిగా ఒక ప్రశ్న ఇచ్చి, మొత్తం మీద ఎనిమిది ప్రశ్నలు ఇవ్వాలి. అందులో ఐదింటికి సమాధానాలు వ్రాయమనాలి.

మొత్తం 70 మా

AG & SG SIDDHARTH DEGREE COLLEGE OF ARTS & SCIENCES: VUYYURU – 521165.
(An antonymous college in the jurisdiction of Krishna University, machilipatnam)
SEMESTER AND EXAMINATIONS, APRIL 2023

నమూనా ప్రశ్నాపత్రం

Course code: TEL T21A (Telugu II).

Max.Marks 70M

Time: 3 Hrs.

Pass Min : 28M

SECTION – A

- I. ఈ క్రింది వాటిలో ఐదింటికి సంగ్రహ రూప సమాధానాలు వ్రాయండి. 4 x 5 = 20
1. కొండవీడు
 2. కథానికను పరిచయం చేయండి.
 3. 'కన్యక' ఖండికను వివరించండి.
 4. తెలుగు నాటక సాహిత్యాన్ని తెల్పండి.
 5. ఉత్తమ విమర్శకుని లక్షణాలు.
 6. ఆధునిక కవిత్వం - పరిచయం.
 7. కాళీపట్నం రామారావు.
 8. అనిసెట్టి సుబ్బారావు.

SECTION -- B

- II. క్రింది వానిలో ఐదింటికి వ్యాస రూప సమాధానాలు వ్రాయండి. 5 x 10 = 50 మా
1. శ్రీ దువ్వూరి 'కొండవీడు' ఖండికలో ఇచ్చిన సందేశాన్ని తెలపండి.
 2. 'భయం' కథానికలో రచయిత అభిప్రాయాన్ని వివరించండి.
 3. 'రథ చక్రాలు' నవల్లోని ఇతివృత్తాన్ని విశ్లేషించండి.
 4. యక్షగానాన్ని సమీక్షించండి.
 5. విమర్శ స్వరూప స్వభావాన్ని వివరించండి
 6. ఆధునిక కవిత్వ ఆవిర్భావ వికాసాన్ని తెలపండి.
 7. తెలుగు సాహిత్య విమర్శను వివరింపుము.
 8. సాహిత్య ప్రక్రియగా 'నవల' స్థానాన్ని విమర్శించండి.

AG & SG SIDDHARTH DEGREE COLLEGE OF ARTS & SCIENCES: VUYYURU – 521165.
(An antonymous college in the jurisdiction of Krishna University, machilipatnam)
SEMESTER AND EXAMINATIONS, APRIL 2023

నమూనా ప్రశ్నాపత్రం

Course code: TEL T21A (Telugu II).

Max.Marks 70M

Time: 3 Hrs.

Pass Min : 28M

SECTION – A

- I. క్రింది వానిలో నాలుగింటికి సంగ్రహ రూప సమాధానాలు వ్రాయండి. 4 x 5 = 20 మా.
1. ఆధునిక కవిత్వ లక్షణాలను తెలపండి. L.I
(లేదా)
గురజాడ అప్పారావు L.I
2. కొండవీడు. L.I
(లేదా)
అనిసెట్టి సుబ్బారావు. L.I
3. తెలుగు నవల. L.2
(లేదా)
'రథచక్రాలు' లో మరియుమ్మ పాత్ర. L2
4. కథానిక లక్షణాలు తెలపండి. L2
(లేదా)
'భయం' కథలో సొమ్ముల గురువడు పాత్రను వివరించండి. L2
5. యక్షగానం పాఠ్యాంశంలో కేశవవర్మ పాత్రను వ్రాయండి. L3
(లేదా)
విమర్శను నిర్వచించి, ప్రయోజనాలను తెలపండి. L3

SECTION – B

- II. క్రింది వానిలో ఐదింటికి వ్యాస రూప సమాధానాలు వ్రాయండి. 5 x 10 = 50 మా.
6. ఆధునిక కవిత్వం ఆవిర్భావ వికాసాలను వివరించండి. L1
(లేదా)
కన్యక ఇతివృత్తాంతాన్ని తెలియజేయండి. L1
7. అనిసెట్టి మాతృ సంగీతాన్ని వివరించండి. L2
(లేదా)
'భయం' కథను సంగ్రహంగా తెలపండి. L2
8. 'రథచక్రాలు' నవల సారాంశాన్ని రాయండి. L2
(లేదా)
'రథచక్రాలు' నవలను సమీక్షించండి. L2
9. 'యక్షగానం' నాటిక ఇతివృత్తాన్ని వ్రాయండి. L1
(లేదా)
'యక్షగానం' నాటికను సమీక్షించండి. L1
10. విమర్శ భేదాలను వివరించండి. L3
(లేదా)
ఉత్తమ విమర్శకుని లక్షణాలను తెలుపండి. L3

**A.G& S.G.SIDDHARTHA DEGREE COLLEGE OF ARTS &
SCIENCE**

VUYYURU-521165, KRISHNA Dt., A.P.(Autonomous)

Accredited by NAAC with "A" Grade

2021-2022



DEPARTMENT OF COMMERCE(PG)

M.Com

MINUTES OF BOARD OF STUDIES

ODD SEMESTER

29-11-2021



**AG&SGS DEGREE COLLEGE OF ARTS AND SCIENCE
VIJAYAWADA-10**

*(An Autonomous college under the jurisdiction of Krishna University)
Reaccredited at the level 'A+' by the NAAC*

DEPARTMENT OF COMMERCE

Minutes of Board of Studies Meeting (Online) of Department of Commerce for M.Com held on 29/11/2021, Monday at 11.30 AM. The following members were present.

Members Present		
Name of the Member	Role	Signature
Dr. T.Venkateswara Rao HOD Department of Commerce Mobile No: 9848726150/9491737921	Chairman	
Dr. R. Padmaja, Assistant Professor in Business Management, Krishna University, Machilipatnam. Mobile: 9440532444,	University Nominee	
Dr.R. Siva Ram Prasad. Santha Kumari, Professor, Dean Department of Commerce & Business Administration Acharya Nagarjuna University, Nagarjuna Nagar, Guntur Mobile No: 9849856589	Subject Expert	
Prof. Rajesh C Jampala Dean Department of Commerce & Business Management PBS College of Arts & Science, Vijayawada. Mobile No: 9866806069	Subject Expert	
Sai Babu, Vuyyuru	Alumnus	
Sri V.V. Punna Rao General Manager KCP Sugar Pvt., Ltd, Vuyyuru. Mobile No: 9704456972	Industry Expert	
Kum Mohana Krishna Department of Commerce (PG) AG&SGS Degree College of Arts & Science, Vuyyuru	Member	
Y. Swarna Latha Department of Commerce (PG) AG&SGS Degree College of Arts & Science,	Member	
G. Kiran Kumar Department of Commerce (PG) AG&SGS Degree College of Arts & Science, Vuyyuru	Member	

**Agenda for Board of Studies meeting for the
Master of Commerce (M.Com)
PG Department of Commerce**

To evaluate and recommend Programme Structure for Master of Commerce program (M.Com) under CBCS for the students admitted in the academic year 2021-22.

1. To explore the possibility of new courses or combination of courses.
2. To assess the potential of the courses against the employment prospects.
3. To assess the compatibility of practical courses with theory courses.
4. To approve the structure of Model Question Papers with COs and levels of Bloom's taxonomy for all courses of I&III semesters of M.Com.
5. To approve the list of examiners and paper setters of all the courses.
6. To approve the course outcomes (COs) for all the courses of I & III (ODD) Semesters of M.Com.
7. Any other matter with the permission of the chair.

516

RESOLUTIONS

1. Discussed and recommended the syllabi of I and III semester of M.Com, for the approval of the Academic Council.
2. Discussed and recommended **Dual Specialisation in 1. Accounting & Taxation 2. Banking, Insurance & Finance** for III semester of M.Com, for the approval of the Academic Council.
3. Discussed and recommended to replace the 'Unit-V' of 'Information Technology for Business' by MS Office (Advanced).
4. Discussed and recommended the Elective Paper 'TALLY with GST' with Lab facility.
5. Discussed and recommended the Lab facility for III Semester Students for e-filing, visiting Web-sites to acquire the knowledge about Stock Markets, Mutual Funds etc.
6. Discussed and recommended the Open Elective Paper for Non-commerce Post Graduates 'Basics of Financial Literacy' about Investments and Stock Markets.
- 7.
8. Discussed and recommended the Model Question Papers of I and III Semesters of M.com., for the approval of the Academic Council.
9. Discussed and recommended the guidelines to be followed by the question paper setter of M.com I and III semesters. For the approval of the Academic Council.
10. Discussed and recommended the following teaching and evaluation methods for the approval of Academic Council.

Teaching Methods:

Besides the conventional methods of teaching, we use modern technology i.e., using of LCD projector to display on U boards and online teaching etc., for better understanding of concept.

Evaluation of student is done by the following procedure:

- i. Out of maximum 100 marks in each paper, 30 marks shall be allocated for internal assessment.
- ii. Out of 30 marks, 20 marks are allocated for announced internal tests. Four announced internal tests will be conducted and average of these Four tests shall be deemed as the marks obtained by the students, out of 10 marks 5 marks are allocated to assignments and seminars and remaining 5 marks are allocated to candidate's percentage of attendance.

Semester-End Examinations:

- i. The maximum marks for Semester-End Examinations shall be 70 marks and duration of the examination shall be 3 Hours.
- ii. Semester-End Examinations shall be conducted in theory papers at the end of every Semester.

11. Discussed and recommended for organising National seminars, Guest Lectures, Work-shops to upgrade the knowledge of students, for the approval of the Academic Council.
12. Discussed and empowered the H.O.D. to suggest the panel of paper setters and Examiners to the Controller of Examinations.

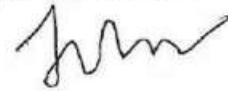

CHAIRMAN

M.Com:**PSOs:**

PSO1: To provide an opportunity for graduates to acquire theoretical as well as practical inputs in commerce to enter a career in professional areas of commerce and finance such as taxation, consultancy and financial services.

PSO2: To develop advanced theoretical knowledge and research capabilities to able to pursue academic and research focused careers.

POs:

PO1: Business Environment and Domain Knowledge (BEDK): Economic, legal and social environment of Indian business. Graduates are able to improve their awareness and knowledge about functioning of local and global business environment and society. This helps in recognizing the functioning of businesses, identifying potential business opportunities, evolvment of business enterprises and exploring the entrepreneurial opportunities.

PO2: Critical thinking, Business Analysis, Problem Solving and Innovative Solutions (CBPI): Competencies in quantitative and qualitative techniques. Graduates are expected to develop skills on analyzing the business data, application of relevant analysis, and problem solving in other functional areas such as marketing, business strategy and human resources.

PO3: Global Exposure and Cross-Cultural Understanding (GECCU): Demonstrate a global outlook with the ability to identify aspects of the global business and Cross Cultural Understanding.

PO4: Social Responsiveness and Ethics (SRE): Developing responsiveness to contextual social issues/ problems and exploring solutions, understanding business ethics and resolving ethical dilemmas. Graduates are expected to identify the contemporary social problems, exploring the opportunities for social entrepreneurship, designing business solutions and demonstrate ethical standards in organizational decision making. Demonstrate awareness of ethical issues and can distinguish ethical and unethical behaviors.

PO5: Effective Communication (EC): Usage of various forms of business communication, supported by effective use of appropriate technology, logical reasoning, articulation of ideas. Graduates are expected to develop effective oral and written communication especially in business applications, with the use of appropriate technology (business presentations, digital communication, social network platforms and so on).

PO6: Leadership and Teamwork (LT): Understanding leadership roles at various levels of the organization and leading teams. Graduates are expected to collaborate and lead teams across organizational boundaries and demonstrate leadership qualities, maximize the usage of diverse skills of team members in the related context.

PO7: Knowledge Application (KA): Acquire knowledge in different areas of management such as finance, marketing, accounting, human resource and operations and apply

AG & SG Siddhartha Degree College of Arts & Science (Autonomous), Vuyyuru – 521 165.

(An autonomous college in the jurisdiction of Krishna University, Machilipatnam)

**M.COM SEMESTER – I
SYLLABUS**

CO101: MANAGEMENT THEORY AND PRACTICE

Unit–I: Introduction: Management, Concept, Significance, Levels, Skills, Functions and Principles - Management as an Art, Science and Profession – Social responsibilities of business.

Unit–II: Planning: Nature, Purpose, Process of Planning, Types of Plans – Premising & Forecasting, Decision Making: Concept, Process, Management By Objectives: Concepts, Process. Advantages and Limitations.

Unit–III: Organizing: Process - Formal and Informal Organizations -Departmentation: Methods of departmentation, Span of Control; V.A. Graicuna’s Theory - Factors Determining Span of Control - Delegation: Concept, Process, Advantages and Principles of Effective Delegation; Decentralization: Factors, Advantages and Disadvantages. Line and Staff: Concept- Reasons for Conflicts between Line and Staff and Measures to Overcome; Committees, Types of Committees.

Unit–IV: Staffing: Nature and Importance of Staffing, Elements of Staffing. Directing: Meaning, Assumptions of Human Behavior by Douglas McGregor, Edgar Shien and Elton Mayo.

Unit–V: Motivation: Significance, Process-Theories of Maslow, Herzberg, Porter and Lawler; Leadership: Trait Approach, Leadership Styles, Managerial Grid; Likert’s Four Systems of Leadership- Communication: Importance, Process, Barriers, Measures to overcome Barriers of an Effective Communication. Controlling: Basis - Control Process, Requirements of adequate Control - Techniques of control, PERT and CPM

Suggested Books:

- Heinz Wihrich., H.Koontz and Markv Cannice, *Management*, 13ed. 2010, Tata McGraw, New Delhi
- Prasad L.M, Principles and Practice of Management, Edition2019, Sultan Chand and Sons, New Delhi.
- Rama Swamy T, Principles of Management. First Ed.,2014, Himalaya Publishing House, Mumbai.

Stoner, J. *Management*, 6th ed., 1995, Pearson Education, New Delhi

M.COM. DEGREE EXAMINATIONS - First Semester

MANAGEMENT THEORY AND PRACTICE

(2017-2018 Regulation Onwards)

Duration: 3 hours

MODEL QUESTION PAPER

Maximum Marks: 70

SECTION- A

1. Answer All Questions

5×4=20 Marks

i. a) Concept of management

OR

b) Sills of management

ii. a) Explain the purpose of Planning

OR

b) Distinguish between the concepts Delegation and Decentralization.

iii. a) Classify the types of Committees.

OR

b) Define Departmentation.

iv. a) Define Staffing.

OR

b) Explain Executive Development Programme

v. a) Show the list of Leadership Traits.

OR

b) Define PERT AND CPM.

SECTION – B

Answer All Questions

5×8=40Marks

2. a) Explain the Nature and significance of Management.

(Or)

b) Discuss the functions of Management.

3. a) Define MBO. Explain the steps in MBO process.

(Or)

b) Describe steps in the process of Planning.

4. a) Examine the methods of Departmentation with merit and limitations of each.

(Or)

b) Define Span of Management. Analyze determining factors that influence span of management.

5. a) Identify the nature and elements of staffing.

(Or)

b) Distinguish between theory X and theory Y proposed by McGregor.

6. a) Examine the motivation theory of Need Hierarchy.

(Or)

b) Define Leadership. Categorize the Styles of leadership

SECTION - C

Answer the following question.

(1 x 10=10 marks)

7. a) Define Management. Explain the 14 principles of management as given by Henry Fayol.

(Or)

b) Define Communication. Analyze various barriers to effective communication. Suggest Measures to make communication more effective

The Guidelines to be followed by the question paper setters in **MANAGEMENT THEORY AND PRACTICE** for the first semester-end exams

PAPER TITLE: MANAGEMENT THEORY AND PRACTICE

PAPER-1

Semester-1

Maximum Marks: 70

Duration: 3 Hours

Weightage for the question paper

Syllabus	Section –A (short answer questions) (with internal choice)	Section- B (Long answer questions) (with internal choice)	Section –C (essay question) (with internal choice)
Unit -1	1 (a or b)	1 (a or b)	Any unit
Unit -2	1 (a or b)	1 (a or b)	
Unit -3	1 (a or b)	1 (a or b)	
Unit -4	1 (a or b)	1 (a or b)	
Unit -5	1 (a or b)	1 (a or b)	

- Each short answer question carries 4 marks in section-A.
- Each long answer question carries 8 marks in section-B.
- Each essay answer question carries 10 marks in section-C.

A.G&S.G .Siddhartha Degree College of Arts & Science-Vuyyuru- 521165

List of Paper Setters

Subject Name: Management Theory and Practice	Course: M.Com.	Course Code: CO111	Department: Commerce (PG)
1. Dr.Md.S.Rahaman Associate Professor, Department of Commerce & Business Administration, P.B Siddhartha College of Arts & Science Vijayawada. Mobile No. : 9866965767.	2. Dr. S.Srinivasa Rao, Assistant Professor, Department of Commerce, T.J.P.S.College, Guntur. Mobile No.: 9440887484.		

M.COM SEMESTER – I
SYLLABUS

CO102: BUSINESS ECONOMICS

Unit-I: Introduction – Definition, Nature and Scope of Managerial Economics; Economic Goals of a Business Firm: Profit Maximization Vs Wealth Maximization, Sales Revenue Maximization.

Unit-II: Consumer Equilibrium under Cardinal and Ordinal Utility - Demand Analysis – Law of Demand – Demand Function and determinants of Market Demand – Concept of Price, Cross, Income and Promotional Elasticity; their measurement and relevance in Managerial Decision – Making Methods of Demand Forecasting.

Unit-III: Firm’s Equilibrium – Iso-quant and Iso-cost analysis; Least – Cost Combination of inputs – The law of Diminishing Marginal Returns in Production – Production Function – Total Product, Marginal and Average Product Curves, their inter – relationships – Cobb – Douglas Production Function and its relevance - Scale and proportion, Cost Functions – Derivation of total, marginal and average cost functions – Long run cost curves

Unit-IV: Market Structures and their characteristics – Pricing and output Decisions of firm under different Market structures – Perfect Competition, Pure Monopoly, Oligopoly, Monopolistic / Imperfect Competition under short and long runs. Discriminative Monopoly Regulation of Monopoly through Prices and Taxes.

Unit-V: Pricing Practices of Firms – Objectives of Pricing Policy – Approaches to Pricing New Products; Skimming Price, Penetration Pricing, Costs Plus Pricing, Managerial Cost Pricing, Psychological Pricing, Odd Number Pricing, Regulated Pricing, Predatory Pricing

Suggested Books:

- Gauvray Datt and Ashwani Mahajan, Indian Economy. 5th Ed, 2015, S Chand and Co, New Delhi.
- Mithani DM, Managerial Economics-Theory and Applications,5th Ed,2010,Himalaya publishing house ,Mumbai.
- Thomas R, Christopher Charles, Maurice, “Managerial Economics: Concepts and .Applications”, 4th 2012, Tata McGraw-Hill, New Delhi..
- Sudip Chaudhuri, Anindya Sen, Economics,19th Ed,2016,Tata Mc Grail Education Pvt Ltd, New Delhi

MODEL QUESTION PAPER
M.COM. DEGREE EXAMINATIONS
First Semester
BUSINESS ECONOMICS
(2017-2018 Regulation Onwards)

Duration: 3 hours

Maximum Marks: 70

SECTION- A

1. Answer All Questions

5×4=20 Marks

i. a) Define Wealth maximization

OR

b) Distinguish Business Economics from Managerial Economics.

ii. a) Explain Demand function

OR

b) Explain Consumer Equilibrium

iii. a) What is Marginal cost

OR

b) Explain Cobb-Douglas production function.

iv. a) Define Perfect competition.

OR

b) Define Oligopoly.

v. a) Explain Penetration Pricing.

OR

b) Analyse Good value strategy.

SECTION – B

Answer All Questions

5×8=40Marks

2. a) Define Business economics? Discuss its nature and scope?

(OR)

b) What are the economic goals of a firm?

3. a) What is the meaning of Demand? What are the determinants of market demand?

(OR)

b) Explain about the income elasticity of demand with some examples?

4. a) Examine the firm's equilibrium using ISOCOST and ISOQUANT Analysis?

(OR)

b) Explain the managerial uses of cost concepts?

5. a) Distinguish between perfect competition and monopolistic competition?

(OR)

b) Explain the features of oligopoly?

6. a) Examine briefly about objectives of pricing policy?

(OR)

b) Outline in detail about cost plus pricing and managerial cost pricing?

SECTION C - (1 x 10=10 marks)

Answer the following question.

7. a) Discuss how price determined under perfect competitive market?

(OR)

b) Explain the cost output relationships both in short-run and long-run?

The Guidelines to be followed by the question paper setters in BUSINESS ECONOMICS for the first semester-end exams

PAPER TITLE: BUSINESS ECONOMICS

PAPER-2

Semester-1

Maximum Marks: 70

Duration: 3 Hours

Weightage for the question paper

Syllabus	Section –A (short answer questions) (with internal choice)	Section- B (Long answer questions) (with internal choice)	Section –C (essay question) (with internal choice)
Unit -1	1 (a or b)	1 (a or b)	Any unit
Unit -2	1 (a or b)	1 (a or b)	
Unit -3	1 (a or b)	1 (a or b)	
Unit -4	1 (a or b)	1 (a or b)	
Unit -5	1 (a or b)	1 (a or b)	

- Each short answer question carries 4 marks in section-A.
- Each long answer question carries 8 marks in section-B.
- Each essay answer question carries 10 marks in section-C.

A.G&S.G .Siddhartha Degree College of Arts & Science-Vuyyuru- 521165

List of Paper Setters

Subject Name: Business
Economics

Course: M.Com

Course Code: CO112

Department:Commerce (PG)

1. Dr.J.Durga Prasad
Associate Professor,
Department of Commerce & Business
Administration,
P.B Siddhartha College of Arts & Science,
Vijayawada.
Mobile No. 9848515628.

2. Dr. K.Sivaji,
Assistant Professor,
Department of Commerce & Business &
Administration,
T.J.P.S.College,
Guntur.
Mobile No.: 9440520219.

AG & SG Siddhartha Degree College of Arts & Science (Autonomous), Vuyyuru – 521 165.
(An autonomous college in the jurisdiction of Krishna University, Machilipatnam)

**M.COM SEMESTER – I
SYLLABUS**

CO103: BUSINESS ENVIRONMENT

Unit-I: Business Environment: Components and Significance - Nature of Business Environment - Techniques of Environmental Scanning and Monitoring – **Economic Scope – Cultural, Political, Technological and External Factors Influencing Business Environment – Challenges- Economic systems.**

Unit-II: Economic Environment of Business: Significance for Business – Economic Planning – Objectives and Achievements; Government policies – Industrial policy of 1991; Fiscal policy; **Economic Reforms and LPG**

Unit-III: Political and Legal Environment of Business: Political Institutions – Legislature, Executive and Judiciary – Changing Dimensions of Legal Environment in India; **Patents Act-1970, SICA-1985, SEZ Act-2005.**

Unit-IV: Cultural and Technological Environment: Elements of Socio – Cultural Environment; Impact on Business – Social Audit - Technological Environment in India; Technology Transfer – Technology Policy.

Unit -V: International and Recent Issues in Environment: Multinational Corporations; Foreign Collaborations and Indian Business; International Economic Institutions: **WTO, World Bank, IMF and their importance to India;** Foreign Trade Policies.

Suggested Books

1. Francis Cherunilam, *Business Environment*, 25th revised edition 2017, Himalaya Publishing House, Mumbai.
2. Fernando, A.C., *Business Environment*, 1st edition 2011, Pearson, Delhi.
3. Suresh Bedi, *Business Environment*, 1st edition 2005, Excel Books, New Delhi,
4. Adhikary.M. *Economic Environment of Business*, 2004, Sultan Chand & Sons, New Delhi.
5. Aswathappa.K. *Essentials of Business Environment*, 12th revised edition 2014, Himalaya Publishing, Delhi.
6. Justin Paul, *Business Environment*, Text and Cases, 12th edition 2018, Tata McGraw Hill.
7. H.L.Ahuja, “*Economic Environment of Business*”, 13th edition 2016, S.Chand, New Delhi.

MODEL QUESTION PAPER
M.COM. DEGREE EXAMINATIONS

First Semester
BUSINESS ENVIRONMENT
(2017-2018 Regulation Onwards)

Duration: 3 hours

Maximum Marks: 70

SECTION- A

1. Answer All Questions

5×4=20 Marks

- i. a) Define Concept of Environment (CO1)(L1)
OR
b) Explain Business Environment Scanning (CO1)(L2)
- ii. a) Examine the Significance of Economic Environment of Business(CO2) (L4)
OR
b) Define LPG (CO2) (L1)
- iii. a) Define Political Institutions (CO3) (L1)
OR
b) Define Legal Environment in India (CO3) (L1)
- iv. a) Define Cultural Environment (CO4) (L1)
OR
b) Define Technological Policy (CO4) (L1)
- v. a) Define Foreign Collaboration(CO5) (L1)
OR
b) Define WTO(CO5) (L1)

SECTION – B

Answer All Questions

5×8=40Marks

2. (a) Define Business Environment? Explain the nature and significance of Business Environment? (CO1) (L1)
(OR)
(b) Explain various techniques of environmental scanning? (CO1) (L2)
3. (a) What is economic planning? Explain the objectives of present economic plan? (CO2) (L1)
(OR)
(b) Critically examine the new industrial policy resolutions? (CO2) (L4)

4. (a) Define the political institutions? Explain the role of Government towards Business. (CO3) (L1) (L2)

(OR)

(b) Identify the role of SEZ act 2005 in the present context? (CO3) (L3)

5. (a) Explain the elements of socio-cultural elements? (CO4) (L2)

(OR)

(b) Discuss the importance of technological environment in India? (CO4) (L6)

6. (a) Define MNC? Explain the scope and importance of MNC? (CO5) (L1)(L2)

(OR)

(b) Determine the role of IMF in India? (CO5) (L5)

SECTION - C

Answer the following question.

(1 x 10=10 marks)

7. (a) Define privatization? Explain the merits and demerits of privatization? (CO3)(L1)(L2)

(OR)

(b) Why WTO replaced GATT - Impact of Regional Trading Agreement on WTO?

(CO5) (L1)

The Guidelines to be followed by the question paper setters in BUSINESS ENVIRONMENT for the first semester-end exams

PAPER TITLE: BUSINESS ENVIRONMENT

PAPER-3 Semester-1 Maximum Marks: 70 Duration: 3 Hours

Weightage for the question paper

Syllabus	Section –A (short answer questions) (with internal choice)	Section- B (Long answer questions) (with internal choice)	Section –C (essay question) (with internal choice)
Unit -1	1 (a or b)	1 (a or b)	Any unit
Unit -2	1 (a or b)	1 (a or b)	
Unit -3	1 (a or b)	1 (a or b)	
Unit -4	1 (a or b)	1 (a or b)	
Unit -5	1 (a or b)	1 (a or b)	

- Each short answer question carries 4 marks in section-A.
- Each long answer question carries 8 marks in section-B.
- Each essay answer question carries 10 marks in section-C.

The Question Paper Setters are requested to cover all the topics in the syllabus stipulated as per the weightage given by us.

A.G&S.G .Siddhartha Degree College of Arts & Science-Vuyyuru- 521165

List of Paper Setters

Subject Name: Business Environment	Course: M.Com	Course Code: CO113	Department:Commerce (PG)
1. Mrs.B.Kalpana Assistant Professor Department of Commerce & Business Administration, P.B Siddhartha College of Arts & Science Vijayawada. Mobile No. 7842669134.		2. Dr.J.Pratap Reddy, Professor, Dept.of Commerce, T.J.P.S.College, Guntur, Mobile: 9440542609.	

**M.COM SEMESTER – I
SYLLABUS**

CO104: ENTREPRENEURSHIP DEVELOPMENT

UNIT-I:

Entrepreneur: Evolution, Characteristics, Types, Functions of Entrepreneur - Factors influencing entrepreneurship - Barriers to entrepreneurship - Growth of Entrepreneurship in India -Women entrepreneurship in India - Role of Entrepreneurship in Economic Development

UNIT-II:

Idea Generation and Opportunity Assessment: Importance of Ideas in Entrepreneurship - Sources of New Ideas – Techniques for generating ideas- Steps in assessing business potential of an idea- Opportunity Recognition- sources and process- Steps in tapping opportunity.

UNIT-III:

Financing Of Enterprises: Need for Financial Planning- Sources of finance, Capital Structure, Term-loan, - Sources of Short-Term Finance, Venture capital, Export Finance,- Institutional Finance To Entrepreneurs, - Preparation of Business Plans.

UNIT-IV:

Institution support in small business enterprises: Introduction – central level institutions- KVIC;SIDO;NSIC ltd; National Productivity Council (NPC); EDII – State level institutions –DIC-SFC-SSIDC-Industry Associations- CII;FICCI;ASSOCHAM.

UNIT-V:

Government Policy and Taxation Benefits : Government Policy for SSIs- Need for tax benefits-Tax Holiday; Rehabilitation allowance ; Investment allowance ; Tax concessions for SSIs in rural and Rural and backward areas.

TEXT BOOKS

1. Osterwalder, Alexander and Yves Pigneur; “Business Model Generation”, John Wiley & Sons, New Jersey, 2012.
2. Roy Rajeev, “Entrepreneurship“ Oxford Latest Edition, 2008

REFERENCE

1. Arya Kumar, Entrepreneurship, 1st Edition, Pearson, Delhi, 2012.
2. Poornima M. Ch., Entrepreneurship Development- Small Business Enterprises, 1st Edition, Pearson, Delhi, 2009
3. Afuah, Allan; “Business Models: A Strategic Management Approach”, 1st Edition, McGraw-Hill, New York, 2004.
4. E. Gordon & K. Natarajan “Entrepreneurship Development” 6th Revised Edition, Himalaya Publishing house, 2008,

AG & SG Siddhartha Degree College of Arts & Science (Autonomous), Vuyyuru – 521 165.
(An autonomous college in the jurisdiction of Krishna University, Machilipatnam)

MODEL QUESTION PAPER
M.COM. DEGREE EXAMINATIONS
First Semester
ENTREPRENEURSHIP DEVELOPMENT
(2017-2018 Regulation Onwards)

Duration: 3 hours

Maximum Marks: 70

SECTION- A

1. Answer All Questions

5×4=20 Marks

i. a) Distinguish Entrepreneurship Vs. Intrapreneurship.

OR

b) Define an Entrepreneur

ii. a) Define the source of Ideas.

OR

b) Business Development

iii. a) What do you mean by Working Capital Management ?

OR

b) Project appraisal

iv. a) KVIC

OR

b) CII

v. a) Meaning of SSIs or

OR

b) Explain Tax Holiday

SECTION – B

Answer All Questions

5×8=40Marks

2. a) Explain the importance of entrepreneurship in economic development.

(Or)

b) Elaborate the role of women entrepreneurship in India.

3. a) What are the steps in assessing business potential of an idea?

(Or)

b) Explain the importance of ideas in entrepreneurship.

4. a) What is meant by Venture Capital? Explain the relevance of Venture Capital finance in Economic Development.

(Or)

b) Discover the role of institutional finance in entrepreneurship development.

5. a) Examine the role of SFC in supporting small business enterprises in India.

(Or)

b) Evaluate the role of SFC in supporting small business enterprises

6. a) Critically examine the policy of the Govt. towards SSIs.

(Or)

b) What are the tax concessions available to SSIs in rural and backward areas?.

SECTION - C

Answer the following question.

(1 x 10=10 marks)

7. a) What are the guidelines observed for project report preparation?

(Or)

a) Distinguish between management and entrepreneurship.

The Guidelines to be followed by the question paper setters in ENTREPRENEURSHIP DEVELOPMENT for the first semester-end exams

PAPER TITLE: ENTREPRENEURSHIP DEVELOPMENT

PAPER-4 Semester-1 Maximum Marks: 70 Duration: 3 Hours

Weightage for the question paper

Syllabus	Section –A (short answer questions) (with internal choice)	Section- B (Long answer questions) (with internal choice)	Section –C (essay question) (with internal choice)
Unit -1	1 (a or b)	1 (a or b)	Any unit
Unit -2	1 (a or b)	1 (a or b)	
Unit -3	1 (a or b)	1 (a or b)	
Unit -4	1 (a or b)	1 (a or b)	
Unit -5	1 (a or b)	1 (a or b)	

- Each short answer question carries 4 marks in section-A.
- Each long answer question carries 8 marks in section-B.
- Each essay answer question carries 10 marks in section-C.

The Question Paper Setters are requested to cover all the topics in the syllabus stipulated as per the weightage given by us.

A.G&S.G .Siddhartha Degree College of Arts & Science-Vuyyuru- 521165

List of Paper Setters & External Examiners

Subject Name: Entrepreneurship Development	Course: M.Com	Course Code: CO114	Department:Commerce (PG)
1. Mrs.G.Lalitha Madhavi Assistant Professor Department of Commerce & Business Administration P.B Siddhartha College of Arts & Science Vijayawada. Mobile No.: 7799209460		2. Dr. S.Srinivasa Rao, Assistant Professor, Department of Commerce, T.J.P.S.College, Guntur. Mobile No.: 9440887484.	

M.COM SEMESTER – I
SYLLABUS

CO105: INFORMATION TECHNOLOGY FOR BUSINESS

Unit-I: Information Technology (IT) in Business Environment: Business in the Information Age - Pressures and Responses, Why do we need to know about Information Technology, What is an Information System, Capabilities of Information Systems - Basic concepts of Information Systems, organizations - Structures and IT support - IT support at different organizational levels, Managing IT in organizations

Unit-II: IT Infrastructure: Computer Hardware - Input Technologies, Output Technologies - Computer Software - Types of software, general functions of Operating system, Types of application software - Managing organizational Data and Information - Basics of Data arrangement and Access, Traditional file Environment. Databases: Modern Approach, Database Management Systems - Logical Data Models, Data Warehouse. Telecommunications systems and Networks - Network communications software, Internet: Services provided by Internet, World Wide Web, Intranets and Extranets.

Unit-III: Information Systems to Support Business Functions: Transaction Processing Systems, Accounting and Finance Systems, Production Management Systems, Human Resources Management Systems, Integrated Information Systems and Enterprise Resource Planning, Inter-organizational/Global Information Systems. Electronic Commerce - Types, Benefits of E- Commerce, Infrastructure and E-commerce support, Legal and ethical issues in E-commerce. Computer-based Supply chain management and IS Integration: IT supply chain support and systems Integration: Enterprise Resource Planning.

Unit-IV: Data, Knowledge and Decision Support: Decision making and Decision support systems, Enterprise Decision support, Knowledge Management and Organizational Knowledge bases. Intelligent systems in Business: Expert systems, Intelligent Agents.

Unit-V: Strategic Advantage and Information Technology: Strategic Organizations in the Information Age, Business Process Re-engineering, Virtual corporations and Information Technology - Implementing IT: Ethics, Impacts and Society, Ethical Issues, Impact of IT on Organizations and Jobs, on Individuals at Work, Societal Impact and Internet Communities, Protecting Information Systems.

Reference Books:

1. V. Rajaraman- Introduction to Information Technology 2nd Edition (2013), PHI
2. Turban/Rainer/Potter- Introduction to Information Technology, 3rd Edition Willey.
3. Alexis Leon, Mathew Leon, Fundamentals of Information Technology, 2nd Edition (2015) LeonVikas.
4. Turban/Volonino/Wood/O.P. Wali - Information Technology for Management,(2015).

MODEL QUESTION PAPER
M.COM. DEGREE EXAMINATIONS
First Semester
INFORMATION TECHNOLOGY FOR BUSINESS
(2017-2018 Regulation Onwards)

Duration: 3 hours

Maximum Marks: 70

SECTION- A

1. Answer All Questions

5×4=20 Marks

- i. a) What are the differences between Information Technology and Information Systems?

OR

- b) What are the capabilities of information system?

- ii. a) What are the various input devices of the computers?

OR

- b) What are the differences between intranet and extranet

- iii. a) Distinguish integrated information systems

OR

- b) What is a human resource management systems

- iv. a) What are the differences between decision making and decision support systems

OR

- b) Explain knowledge management bases

- v. a) Explain internet communities.

OR

- b) What do you mean by business process re-engineering?

SECTION – B

Answer All Questions

5×8=40Marks

2. a) What is an Information system. Explain the capabilities of Information systems

(OR)

- b) Explain about Information Technology in organizations.

3. a) What is an operating system. Explain the general functions of operating systems.

(OR)

- b) What are the differences between File based approach and Database Approach.

4. a) Explain the types and benefits of E-commerce.

(OR)

b) Explain briefly about computer based supply chain management.

5. a) Explain briefly about the features, benefits and limitations of expert systems.

(OR)

b) Explain intelligent agents and how they are used in today business.

6. a) Explain how Information Technology is implemented in organization and its impact on society.

(OR)

b) What are the ethical issues involved in implementing Information Technology.

SECTION - C

Answer the following question.

(1 x 10=10 marks)

7. a) What is DBMS. Explain the architecture and benefits of this system

(OR)

b) Explain the societal impacts of Information Technology and different ways of protecting Information Systems

The Guidelines to be followed by the question paper setters in INFORMATION TECHNOLOGY FOR BUSINESS for the first semester-end exams

PAPER TITLE: INFORMATION TECHNOLOGY FOR BUSINESS

PAPER-5 Semester-1 Maximum Marks: 70 Duration: 3 Hours

Weightage for the question paper

Syllabus	Section –A (short answer questions) (with internal choice)	Section- B (Long answer questions) (with internal choice)	Section –C (essay question) (with internal choice)
Unit -1	1 (a or b)	1 (a or b)	Any unit
Unit -2	1 (a or b)	1 (a or b)	
Unit -3	1 (a or b)	1 (a or b)	
Unit -4	1 (a or b)	1 (a or b)	
Unit -5	1 (a or b)	1 (a or b)	

- Each short answer question carries 4 marks in section-A.
- Each long answer question carries 8 marks in section-B.
- Each essay answer question carries 10 marks in section-C.

The Question Paper Setters are requested to cover all the topics in the syllabus stipulated as per the weightage given by us.

A.G&S.G .Siddhartha Degree College of Arts & Science-Vuyyuru- 521165

List of Paper Setters & External Examiners

Subject Name: Information Technology For Business	Course: M.Com	Course Code: CO115	Department:Commerce (PG)
1. Mrs.K.Sirisha, Lecturer, Department of Commerce & Business Administration, P.B Siddhartha College of Arts & Science Vijayawada. Mobile No.: 7032617871	2. Dr. K.Sivaji, Assistant Professor, Department of Commerce & Business & Administration, T.J.P.S.College, Guntur. Mobile No.: 9440520219		

AG & SG Siddhartha Degree College of Arts & Science (Autonomous), Vuyyuru – 521 165.
(An autonomous college in the jurisdiction of Krishna University, Machilipatnam)

M.COM SEMESTER – I
SYLLABUS

CO106: QUANTITATIVE TECHNIQUES FOR BUSINESS DECISIONS

UNIT-I: Matrices, Differentiation, Permutations and combinations: Matrices –Basic concepts, Solving system of equations with Cramer’s rule and Inverse method - Differentiation and integration of simple functions and their applications- Permutations and Combinations.

UNIT-II: Correlation and Regression: Correlation: Types of Correlation - Simple and Rank Correlation coefficient in the case of two variables- **Regression: Meaning and importance of Regression Analysis.** Estimation of Lines of Regression in the case of two variables.

UNIT-III: Probability: Concept of Probability: Definitions of Probability, Addition Theorem of Probability, Conditional Probability and Multiplication theorems of Probability, Baye’s Theorem of Probability and its **Applications.**

UNIT- IV: Theoretical distributions: Binomial Distribution, Poisson distribution and Normal distribution – their **Properties and Applications.**

UNIT-V: Testing of Hypothesis: Concept of Testing of Hypothesis, Types of Errors, Standard deviations and Proportions, Z- test for Means, T-test, F-test for two variances and Chi-Square test for goodness of fit and independent of Attributes and their Applications – Confidence intervals.

Suggested Books:

1. S.C. Gupta.-, Fundamentals of Statistics, 7th Revised Edition (2013) Himalaya Publishing House, New Delhi..
2. Sharma, J.K.-, Fundamentals of Business Statistics, 2nd Edition (2000) Pearson Education, New Delhi..
3. Sancheti, Dc & V.K Kapoor, Business Mathematics, 3rd Edition (2014) Sultan Chand & Sons, New Delhi..
4. Arora, P. N., S. Arora- Comprehensive Statistical Methods, 2nd Edition (2007) S. Chand, New Delhi.
5. Sharma, J.K., Quantitative Methods- Theory & Applications, 3rd Edition (2010) Macmillan New Delhi.\

MODEL QUESTION PAPER
M.COM. DEGREE EXAMINATIONS - First Semester
QUANTITATIVE TECHNIQUES FOR BUSINESS DECISIONS
(2017-2018 Regulation Onwards)

Duration: 3 hours

Maximum Marks: 70

SECTION- A

1. Answer All Questions

5×4=20 Marks

i. a) Explain permutations and combinations.

OR

b) Distinguish Differentiation from Integration

ii. a) What is correlation and explain different types of correlation?

OR

b) What are the properties of regression coefficients?

iii. a) State Addition Theorem of Probability

OR

b) Define i) Exhaustive events ii) Equally likely events

iv. a) What is the importance of Poisson distribution?

OR

b) What are the properties of Binomial Distribution

v. a) Distinguish between Type-I and Type-II errors

OR

b) Explain the procedure for testing of hypothesis

SECTION – B

Answer All Questions

5×8=40Marks

2.a) Solve the following Simultaneous Linear Equations by using Cramer's Rule

$$2x+y-Z=3; x+y+z=1; x-2y-3Z=4$$

OR

b)A company has examined its cost structure and revenue structure and has determined that C the total cost, R total revenue, and x the number of units produced are related as: $C=100+0.015x^2$ and $R=3x$ Find the production rate x that will maximize profits of the company. Find that profit. Find also the profit when $x=120$.

3. a) Find the Karl Pearson's Coefficient of Correlation from the following data:

Marks in Economics	45	55	56	58	60	65	68	70	75	80	85
Marks in Statistics	56	50	48	60	62	64	65	70	74	82	90

OR

b) The following data about the sale and advertisement expenditure of a firm is given below.

	Sales(in Crores of Rupees)	Advertisement Expenditure(in Crores of Rs)
Means	40	6
Standard Deviation	10	1.5

Coefficient of Correlation $=r=0.9$

- I. Estimate the likely sales for a proposed advertisement expenditure of Rs. 10 Crores.
- II. What should be the advertisement expenditure if the firm proposes a sales target of 60 Crores of Rupees?

4. a) i) A box contains 6 red, 4 white and 5 blue balls. From this box 3 balls are drawn in succession. Find the probability that they are drawn in the order red, white and blue if each ball is i) replaced ii) not replaced

OR

b) The contents of urns I, II and III are as follows:

1 white, 2 black and 3 red balls,

2 white, 1 black and 1 red balls, and

4 white, 5 black and 3 red balls

One urn is chosen at random and two balls drawn. They happen to be white and red. What is the probability that they came from urns I, II or III?

5.a) What is Normal Distribution? Explain characteristics and importance of the normal distribution.

OR

b) If 5% of the electric bulbs manufactured by a company are defective, use Poisson distribution to find the probability that in a sample of 100 bulbs (i) none is defective, (ii) 5 bulbs will be defective. (Given $e^{-5}=0.007$)

6. a) In a sample of 400 parts manufactured by a factory, the number of defective parts was found to be 30. The company, however, claimed that only 5% of their product is defective. Is the claim tenable?

OR

b) Two types of batteries are tested for their length of life and the following data are obtained:

	No. of Samples	Mean life in Hours	Variance
Type A:	9	600	121
Type B:	8	640	144

Is there a significance difference in the two means? (Table value=2.131)

SECTION - C

Answer the following question.

(1 x 10=10 marks)

7.a) From the following data, use χ^2 -test and conclude whether inoculation is effective in preventing tuberculosis:

	Attacked	Not attacked	Total
Inoculated	31	469	500
Not inoculated	185	1,315	1,500
Total	216	1,784	2,000

OR

b) In order to make a survey of the buying habits, two markets A and B are chosen at two different parts of a city. 400 women shoppers are chosen at random in market A. Their average weekly expenditure on food is found to be Rs.250 with a standard deviation of Rs.40. The figures are Rs.220 and Rs.55 respectively in the market B where also 400 women shoppers are chosen at random. Test at 1% level of significance whether the average weekly food expenditures of the two populations of shoppers are equal.

The Guidelines to be followed by the question paper setters in QUANTITATIVE TECHNIQUES FOR BUSINESS for the first semester-end exams

PAPER TITLE: QUANTITATIVE TECHNIQUES FOR BUSINESS

PAPER-6 Semester-1 Maximum Marks: 70 Duration: 3 Hours

Weightage for the question paper

syllabus	Section –A (short answer questions) (with internal choice)	Section- B (Long answer questions) (with internal choice)	Section –C (essay question) (with internal choice)
Unit -1	1 (a or b)	1 (a or b)	Any unit
Unit -2	1 (a or b)	1 (a or b)	
Unit -3	1 (a or b)	1 (a or b)	
Unit -4	1 (a or b)	1 (a or b)	
Unit -5	1 (a or b)	1 (a or b)	

- Each short answer question carries 4 marks in section-A.
- Each long answer question carries 8 marks in section-B.
- Each essay answer question carries 10 marks in section-C.

The Question Paper Setters are requested to cover all the topics in the syllabus stipulated as per the weightage given by us.

A.G&S.G .Siddhartha Degree College of Arts & Science-Vuyyuru- 521165

List of Paper Setters & External Examiners

Subject Name: Quantitative Techniques for Business Decisions	Course: M.Com	Course Code: CO116	Department: Commerce (PG)
1. Dr.B.Jaya Prakash, Associate Professor, Deputy Head, Department of Commerce & Business Administration P.B Siddhartha College of Arts & Science Vijayawada. Mobile No. 9849813969.		2. Dr.J.Pratap Reddy, Professor, Dept.of Commerce, T.J.P.S.College, Guntur, Mobile: 9440542609.	



**AG&SG SIDDHARTHA COLLEGE OF ARTS AND SCIENCE
VUYYURU
PG DEPARTMENT OF COMMERCE**

M. COM (Final Year) III SEM SYLLABUS

CO301- FINANCIAL ACCOUNTING AND PACKAGES

Unit-I: Introduction to Accounting: Concept – Importance and scope – Generally Accepted Accounting Principles – Objectives, Nature and Scope of Financial Accounting. – Cost Accounting – Management accounting.

Unit-II: Preparation of Financial statements: Income statement and Balance sheet – Bank Reconciliation Statement – Inventory valuation and Depreciation.

Unit-III: Financial Analysis: Objectives – Ratio Analysis – Funds Flow & Cash Flow Analysis.

Unit- IV: Management Accounting: Marginal Costing – CVP analysis – Standard costing and Variance analysis.

Unit- V: Accounting Package- Tally (Theory and practical)



AG&SG SIDDHARTHA COLLEGE OF ARTS AND SCIENCE
VUYYURU
PG DEPARTMENT OF COMMERCE

The Guidelines to be followed by the question paper setters in **CO301- FINANCIAL ACCOUNTING AND PACKAGES** for the third semester-end exams

PAPER TITLE: CO301- FINANCIAL ACCOUNTING AND PACKAGES

PAPER- I Semester-III Maximum Marks: 70 Duration: 3 Hours

Weightage for the question paper

Syllabus	Section –A (Short answer questions) (with internal choice)	Section- B (Long answer questions) (with internal choice)	Section –C (Essay question) (with internal choice)
Unit -1	1 (a or b)	1 (a or b)	Any unit
Unit -2	1 (a or b)	1 (a or b)	
Unit -3	1 (a or b)	1 (a or b)	
Unit -4	1 (a or b)	1 (a or b)	
Unit -5	1 (a or b)	1 (a or b)	

- Each short answer question carries 4 marks in section-A.
- Each long answer question carries 8 marks in section-B.
- Each essay answer question carries 10 marks in section-C.

The Question Paper Setters are requested to cover all the topics in the syllabus stipulated as per the weightage given by us.



**AG&SG SIDDHARTHA COLLEGE OF ARTS AND SCIENCE
VUYYURU
PG DEPARTMENT OF COMMERCE**

MODEL PAPER

CO301- FINANCIAL ACCOUNTING AND PACKAGES

Section - A (5 x 4 Marks = 20 Marks)

Answer the following Questions:

1. a i. Scope of Financial Accounting
ii Accounting Cycle.
- b i Bank Reconciliation Statement
ii Trading Account
- c i Use of Cash inflow
ii Debt Service coverage ratio.
- d i Benefits of accounting standards
ii PV ratio.
- e i Uses of Tally
ii Limitations of Tally.

Section – B (5 x 8 Marks = 40 Marks)

Answer the following Questions:

2. a. Define Generally Accepted Accounting Principles (GAAP). Discuss the features and utility of GAAP.
(OR)
b. Difference between Management and Financial Accounting.
3. a. Explain cash flow and uses of cash inflow.
(OR)
b. Compute cash generated from operations during 2012-2013 from the following data.



AG&SG SIDDHARTHA COLLEGE OF ARTS AND SCIENCE
VUYYURU
PG DEPARTMENT OF COMMERCE

Particulars	April 1, 2012	march31, 2013
Sundry debtors	30000	40000
Sundry creditors	48000	30000
Outstanding expenses	3000	6000
Outstanding income	1000	1000
Stock on trade	55000	55000
Prepaid expenses	3000	2000
Accumulated depreciation	50000	60000
(No retirements during the year)		
Provisions for doubtful accounts	1500	2000
Dividends payable	-----	3000
Bills receivable	10000	12000
Bills payable	8000	6000
Net income before tax (as per P&L a/c)	-----	80000

4. a. What are the features of Managerial costing?

(OR)

b. What are the advantages of standard costing?

5. a. The following are the relating to the activities of National traders ltd;

Debtors velocity (months)	-	3
Stock velocity (months)	-	8
Creditors velocity (months)	-	2
Cross profit ratio (%)	-	25

Gross profit for the current year ended December 31 amounts to Rs. 40000. Closing stock of year is Rs. 10000 above the opening stock. Bills receivable amount to Rs. 25000 and bills payable to Rs.10000 find out. I) sundry debtors ii) closing stock iii) sundry creditors.

(OR)

b. Explain about the profit and loss account.



AG&SG SIDDHARTHA COLLEGE OF ARTS AND SCIENCE
VUYYURU
PG DEPARTMENT OF COMMERCE

6. a. Explain the features of accounting software.

(OR)

b. Describe the process of company in Tally.

Section – C (1x10 Marks = 10 Marks)

Answer the following Question:

7. a. Explain about the standard costing? Advantages and disadvantages of standard costing.

(OR)

b. The trail balance given below, given the adjusting and closing entries and prepare the final a/cs.

Trail Balance			
<u>Debits</u>	Rs	<u>Credits</u>	Rs
Debtors	7580	Capital	8000
Discounts allowed	40	Bad debts received	250
Drawings	600	Bank deposits	2750
Returns inwards	450	Creditors	1250
Rent	360	Returns outwards	350
Salaries	850	Bank overdraft	1570
Travelling expenses	300	Sales	14690
Cash in hand	210	Bills payable	1350
Stock 1 st Jan. 2020	2450		
Purchases	11870		
	<u>27460</u>		<u>27460</u>

Adjustments:

1. The closing stock on 31st December 1973 was rs.4200
2. Three months' rent outstanding.
3. Write off rs.80 as bad debts and create a reason for bad debts @5% on sundry debtors.
4. Interest on bank deposit rs.135 credited by the bankers and interest on overdraft rs.157 debited by them in the pass book have not been entered in the books.

==00==



**AG&SG SIDDHARTHA COLLEGE OF ARTS AND SCIENCE
VUYYURU
PG DEPARTMENT OF COMMERCE**

CO302 - BUSINESS COMMUNICATION

Unit-I: Business Correspondence: Significance - Formal, informal and semiformal correspondence – Describing company activities and structures – Describing job responsibilities – Written Correspondence - Differences between formal and informal writings – Use of formal vocabulary and functional language in business letter writing – Planning effective business letters and responses – e-mail writing skills, call taking etiquette/skills.

Unit-II: Business Information: Completing of Forms - Asking appropriate questions to gather information–Polite phrases of confirmation and communication breakdown- understanding native speaking accents and dialects; Functional language used in making verbal agreements — Effective techniques of making and accepting offers – Efficient written offer making and accepting.

Unit-III: Business Presentations: Basic presentation techniques – Use of information in presenting product features – Explaining technical features for simplification; Giving and interpreting numerical data, Business abbreviations and acronyms - Oral and written conventions for expressing numerical information in English.

Unit-IV: Business Reporting: Effective presentation of oral and written instructions – Presenting and describing company information: Vocabulary of describing graphical and numerical information – Summarizing important information concisely

Unit-V: Feedback and Evaluation: Giving feedback to others - Use of questions in self-assessment elicitation – Functional language of agreement/disagreement and opinion giving – good/bad feedback – Motivating others – Use of conditionals to discuss future possibilities – Discourse strategies for effective relationship – team building skills.



AG&SG SIDDHARTHA COLLEGE OF ARTS AND SCIENCE
VUYYURU
PG DEPARTMENT OF COMMERCE

The Guidelines to be followed by the question paper setters in **CO302 - BUSINESS COMMUNICATION** for the **third semester-end exams**

PAPER TITLE: CO302 - BUSINESS COMMUNICATION

PAPER- II Semester-III Maximum Marks: 70 Duration: 3 Hours

Weightage for the question paper

Syllabus	Section –A (Short answer questions) (with internal choice)	Section- B (Long answer questions) (with internal choice)	Section –C (Essay question) (with internal choice)
Unit -1	1 (a or b)	1 (a or b)	Any unit
Unit -2	1 (a or b)	1 (a or b)	
Unit -3	1 (a or b)	1 (a or b)	
Unit -4	1 (a or b)	1 (a or b)	
Unit -5	1 (a or b)	1 (a or b)	

- Each short answer question carries 4 marks in section-A.
- Each long answer question carries 8 marks in section-B.
- Each essay answer question carries 10 marks in section-C.

The Question Paper Setters are requested to cover all the topics in the syllabus stipulated as per the weightage given by us.



**AG&SG SIDDHARTHA COLLEGE OF ARTS AND SCIENCE
VUYYURU
PG DEPARTMENT OF COMMERCE**

MODEL PAPER

CO302 - BUSINESS COMMUNICATION

Section - A (5 x 4 Marks = 20 Marks)

Answer the following Questions:

1. a i. Differences between formal and informal writings

(OR)

- ii. Written Correspondence

- b i. Communication breakdown

(OR)

- ii. Functional language

- c i. Business abbreviations

(OR)

- ii. Oral and written conventions

- d i. Business Reporting

(OR)

- ii. Graphical and numerical information

- e i. Feedback

(OR)

- ii. Team building

Section – B (5 x 8 Marks = 40 Marks)

Answer the following Questions:

2. a. Define Business Correspondence and explain its Significance and types

(OR)

- b. Define a Business Letter. Explain various parts of a Business Letter.



**AG&SG SIDDHARTHA COLLEGE OF ARTS AND SCIENCE
VUYYURU
PG DEPARTMENT OF COMMERCE**

3. a. Define a Questionnaire. Explain the process of asking appropriate questions to gather information.

(OR)

- b. Explain the concept of Communication Breakdown in detail.

4. a. Define a Business Presentation. Explain various Basic presentation techniques.

(OR)

- b. Explain Oral and written conventions for expressing numerical information in English.

5. a. Explain Effective presentation of oral and written instructions in Business Reporting

(OR)

- b. How to Presenting and describing company information in Business Reporting?

6. a. Explain the Functional language of agreement/disagreement and opinion giving.

(OR)

- b. Explain the Use of conditionals to discuss future possibilities.

Section – C (1x10 Marks = 10 Marks)

Answer the following Question:

7. a. Define Team Building. Explain the team building skills in detail.

(OR)

- b. Explain the Oral and written conventions for expressing numerical information in English.



**AG&SG SIDDHARTHA COLLEGE OF ARTS AND SCIENCE
VUYYURU
PG DEPARTMENT OF COMMERCE**

CO303- CORPORATE ACCOUNTING

Unit - I: Corporate Financial Accounting: Objectives-Scope - Role of Corporate Accountant Analysis and Interpretation of Financial Statements - Inflation Accounting.

Unit - II: Valuation of Shares: Need for Valuation of Shares – Factors Effecting Value of Shares – Methods of Valuation – Impact of Earnings on Share Valuation – Role of Fundamental Analysis and Technical Analysis in Share Valuation – Fair Value of a Share – Buy Back of Equity Shares.

Unit - III: Financial Reporting: Concept, Objectives – Users of Financial Reporting and Specific Purpose of Report – Difficulties in Corporate Reporting– Interim Reporting – Problems – Improving Financial Reporting – Value Added Statements – Disclosure of Value Added Statements – Economic Value Added.

Unit - IV: Consolidated Financial Statements: Definition of Parent or Holding and its Subsidiary – Need for Consolidated Financial Statement – Preparation of Consolidated Balance Sheet of a Holding Company with one Subsidiary – Consolidation of Profit of Loss Account –Consolidated Statement of Changes in Financial Position.

Unit-V: New trends in Accounting: Human Resource Accounting - Environmental Accounting, Social Responsibility Accounting etc.



AG&SG SIDDHARTHA COLLEGE OF ARTS AND SCIENCE
VUYYURU
PG DEPARTMENT OF COMMERCE

The Guidelines to be followed by the question paper setters in **CO303-CORPORATE ACCOUNTING** for the third semester-end exams

PAPER TITLE: CO303- CORPORATE ACCOUNTING

PAPER- III

Semester-III

Maximum Marks: 70

Duration: 3 Hours

Weightage for the question paper

Syllabus	Section –A (Short answer questions) (with internal choice)	Section- B (Long answer questions) (with internal choice)	Section –C (Essay question) (with internal choice)
Unit -1	1 (a or b)	1 (a or b)	Any unit
Unit -2	1 (a or b)	1 (a or b)	
Unit -3	1 (a or b)	1 (a or b)	
Unit -4	1 (a or b)	1 (a or b)	
Unit -5	1 (a or b)	1 (a or b)	

- Each short answer question carries 4 marks in section-A.
- Each long answer question carries 8 marks in section-B.
- Each essay answer question carries 10 marks in section-C.

The Question Paper Setters are requested to cover all the topics in the syllabus stipulated as per the weightage given by us.



**AG&SG SIDDHARTHA COLLEGE OF ARTS AND SCIENCE
VUYYURU
PG DEPARTMENT OF COMMERCE**

MODEL PAPER

CO303- CORPORATE ACCOUNTING

Section - A (5 x 4 Marks = 20 Marks)

Answer the following Questions:

1. a i. Objectives of corporate accounting.
(OR)
ii. Inflation accounting

- b i. Need for valuation of shares.
(OR)
ii. Buy back of shares

- c i. Concept of financial reporting.
(OR)
ii. Economic value added

- d i. Holding company
(OR)
ii. Needs for consolidated financial statement.

- e i. Environmental accounting.
(OR)
ii. Social responsibility accounting.

Section – B (5 x 8 Marks = 40 Marks)

Answer the following Questions:

2. a) Role of corporate accountant.
(OR)
b) From the following information prepare common size income statement for the year ended 2019.

Administrative expenses	rs.30000
Selling & distribution expenses	rs.15000
Cost of sales	75% of net sales
Income Tax	20% of net profit before
Net Income after tax	rs.72000
Other Income	rs.15000



AG&SG SIDDHARTHA COLLEGE OF ARTS AND SCIENCE
VUYYURU
PG DEPARTMENT OF COMMERCE

3. a) Explain the methods of valuation of shares.

(OR)

b) Explain the role of fundamental analysis in the valuation of shares.

4. a) What are the difficulties in corporate reporting?

(OR)

b) Explain the improvement in financial reporting.

5. a) How is consolidated balance sheet prepared?

(OR)

b) A Ltd, acquires all the shares of B ltd on 01-01-2019. From the balance sheet given below prepare a consolidated balance sheet.

Balance sheet as on 31st march 2019

Liabilities	A Ltd (rs)	B ltd (rs)	Asset	A ltd (rs)	B ltd (rs)
Share capital:			Land & buildings	200000	135000
Shares of rs.10 each	400000	150000	plant & machinery	80000	40000
Creditors	140000	60000	furniture	25000	10000
Bills payable	15000	10000	investment in shares of		
Reserve on 1-4-15	105000	20000	B ltd	250000	
Profit and loss a/c	25000	15000	stock	65000	30000
			Debtors	40000	30000
			Bank balance	25000	10000
	<hr/>	<hr/>		<hr/>	<hr/>
	685000	255000		685000	255000
	<hr/>	<hr/>		<hr/>	<hr/>

6. a) Explain advantages of Human Resource Accounting.

(OR)

b) Explain the nature and objectives of social responsibility accounting.



**AG&SG SIDDHARTHA COLLEGE OF ARTS AND SCIENCE
VUYYURU
PG DEPARTMENT OF COMMERCE**

Section – C (1x10 Marks = 10 Marks)

Answer the following Question:

7 a) Explain the role of technical analysis in share valuation.

(OR)

b) The balance sheet of Ganesh Ltd as on 31-3-2018 was as under:

Liabilities	Rs	Assets	Rs
2000 equity shares of rs.100 each	200000	Land buildings	125000
General reserve	50000	Machinery	75000
Surplus a/c	25000	Investment at cost	45000
Creditors	45000	(Market value rs. 37500)	
Provisions for taxation	20000	Debtors	50000
Provident fund	17500	Stock	37500
		Cash at bank	25000
	_____		_____
	357500		357500
	_____		_____

Additional information:

1. Land& building and machinery are valued at rs.137500 and rs.55000 respectively.
2. Of the total debtors. Rs.10000 is bad.
3. Goodwill is to be taken at rs.15000.
4. The normal rate of dividend declared by such type of companies is 15% on the paid up capital.
5. The average rate of dividend declared by such type of companies is 18% on the paid up capital. Calculate the fair value of the equity shares of the company.

==00==



**AG&SG SIDDHARTHA COLLEGE OF ARTS AND SCIENCE
VUYYURU
PG DEPARTMENT OF COMMERCE**

CO304 - DIRECT TAXES

UNIT -I : Income Tax Act 1961: Basic Concepts, Income, Agriculture Income - Residential Status and Incidence of Tax - Incomes Exempt from Tax u/s 10.

UNIT-II : Heads of Income of Individuals; Salaries- income from house property and gain from business or profession, capital gains.

UNIT-III: Head of income from other sources, clubbing up of income set off and carry forward of losses, deductions from gross total income, computation of total income and tax liability.

UNIT- IV: Assessment of Individuals, Hindu Undivided Families, Firms, Association of Persons, Cooperative Societies and Companies.

UNIT – V: Tax Administration; Income Tax Authorities, Assessment procedure, collection and recovery of tax, refunds, penalties and procedures, appeals and revisions.



AG&SG SIDDHARTHA COLLEGE OF ARTS AND SCIENCE
VUYYURU
PG DEPARTMENT OF COMMERCE

The Guidelines to be followed by the question paper setters in **CO304 - DIRECT TAXES** for the third semester-end exams

PAPER TITLE: CO304 - DIRECT TAXES

PAPER- IV Semester-III Maximum Marks: 70 Duration: 3 Hours

Weightage for the question paper

Syllabus	Section –A (Short answer questions) (with internal choice)	Section- B (Long answer questions) (with internal choice)	Section –C (Essay question) (with internal choice)
Unit -1	1 (a or b)	1 (a or b)	Any unit
Unit -2	1 (a or b)	1 (a or b)	
Unit -3	1 (a or b)	1 (a or b)	
Unit -4	1 (a or b)	1 (a or b)	
Unit -5	1 (a or b)	1 (a or b)	

- Each short answer question carries 4 marks in section-A.
- Each long answer question carries 8 marks in section-B.
- Each essay answer question carries 10 marks in section-C.

The Question Paper Setters are requested to cover all the topics in the syllabus stipulated as per the weightage given by us.



**AG&SG SIDDHARTHA COLLEGE OF ARTS AND SCIENCE
VUYYURU
PG DEPARTMENT OF COMMERCE**

MODEL PAPER

CO304 - DIRECT TAXES

Section - A (5 x 4 Marks = 20 Marks)

Answer the following Questions:

1. a. i. Agriculture Income
(OR)
ii. Residential Status
- b. i. House Rent Allowance (HRA)
(OR)
ii. Capital gains
- c. i. Horse races
(OR)
ii. Tax liability
- d. i. Association of Persons
(OR)
ii. Hindu Undivided Families (HUF)
- e. i. Penalties
(OR)
ii. Appeals

Section – B (5 x 8 Marks = 40 Marks)

Answer the following Questions:

2. a. Explain the basic concepts of IncomeTax.
(OR)
b. Define Residential Status. Explain how to compute Tax Liability.
3. a. Define Salary Income. Explain various chargeable Allowances.
(OR)
b. Compute the Salary income of Mr. X for the AY 2020-21.



AG&SG SIDDHARTHA COLLEGE OF ARTS AND SCIENCE
VUYYURU
PG DEPARTMENT OF COMMERCE

(i) Basic salary (per month) ` 60,000.

(ii) Dearness allowance = 50% of basic salary.

(iii) Motor car owned by employer given to employee. Entire running expenses are met by the employer and the car is used for both official and personal purpose by the employee. The engine cubic capacity is above 1.6 litres.

(iv) Provident fund contribution of both employer and employee at 15% of basic salary.

(v) Accommodation owned by the employer is given to the employee. A sum of ` 5,000 per month is deducted towards accommodation from the salary of employee.

(vi) Life insurance premium on policy taken by employee paid by the employer during the year ` 45,000.

4. a. How to you compute the income from other sources?

(OR)

b. Define Total Income. Explain the deductions from gross total income.

5. a. Explain the assessment of individuals.

(OR)

b. Mr. Amitabh prepared the following profit and loss account of his cloth shop for the year ended 31st March, 2020. Find out his income from business for the AY 2020-21. Profit and Loss Account (For the year ended 31st March, 2020)

Particulars	Rs.	Particulars	Rs.
Salaries and wages	33,000	Gross Profit	3,34,725
Rent, etc.	1,600	Gifts received from relatives	275
Household expenses	82,000		
Income Tax	900		
Advertisement	800		
Postage expenses	600		
Gifts to relatives	900		
Fire Insurance Premium	400		
Life Insurance Premium	2,100		
Bad Debts Reserve	800		
Audit Fees	400		
Net profit	2,11,500		
Total	3,35,000	Total	3,35,000



**AG&SG SIDDHARTHA COLLEGE OF ARTS AND SCIENCE
VUYYURU
PG DEPARTMENT OF COMMERCE**

6. a. Explain the procedure of collection and recovery of tax.

(OR)

b. Explain about the Income Tax Authorities.

Section – C (1x10 Marks = 10 Marks)

Answer the following Question:

7. a. Explain the Incomes Exempt from Tax u/s 10.

(OR)

b. 'X' is a salaried employee in a private sector enterprise in Delhi getting Rs.4,000 per month. He was also provided with a free furnished residence which was hired by the employer at Rs. 3,000 per month. The cost of furnishing was Rs. 50,000. In addition he was allowed free the services of a watchman, a gardener and a sweeper who were paid Rs. 2,400, 2,400 and 1,800 per year respectively by the employer. He earned a capital gain (short -term) of Ks. 10,000 from sale of a plot of land, in 1985 he had incurred a short -term capital loss, out of which Ks. 6,000 was carried forward.

Find his Gross Total Income for the AY 2020-21.



**AG&SG SIDDHARTHA COLLEGE OF ARTS AND SCIENCE
VUYYURU
PG DEPARTMENT OF COMMERCE**

CO305 - ADVANCED BANKING

UNIT – I : Central Banking Concept – Central Banking Policy in Developed and Developing Economies – Functions – Note issues – Banker to the Government; Banker to Commercial Banks – Credit Control – Techniques -Structure and Organization of RBI – Role of RBI as Central Bank.

UNIT – II: Structure and Organization of Central Bank in India, USA, UK and EU–Objectives – Central Banking Policy in Developed and Less Developed Countries – A Critical Study of Theory and Practice of Central Banking in India, USA and UK.

UNIT – III: Development of Commercial Banking in UK, USA and India – Study of Nature and Structure of Commercial Banking in India and Abroad – Theories of Asset Management – Commercial Banks, Recent Developments in Commercial Banking in USA, UK and India.

UNIT – IV : Economic Stabilization Policy: Objectives of Monetary Policy – Choosing Between Conflicting Objectives – Monetary and Fiscal Policies and Economic Stabilization – Interdependence of Monetary and Fiscal Policies – Debt Management Policy.

UNIT – V : Emerging Trends – Technological Advancement in Banking Sector –Challenges and Issues – Next Generation Banking.



AG&SG SIDDHARTHA COLLEGE OF ARTS AND SCIENCE
VUYYURU
PG DEPARTMENT OF COMMERCE

The Guidelines to be followed by the question paper setters in **CO305 - ADVANCED BANKING** for the third semester-end exams

PAPER TITLE: CO305 - ADVANCED BANKING

PAPER- V Semester-III Maximum Marks: 70 Duration: 3 Hours

Weightage for the question paper

Syllabus	Section –A (Short answer questions) (with internal choice)	Section- B (Long answer questions) (with internal choice)	Section –C (Essay question) (with internal choice)
Unit -1	1 (a or b)	1 (a or b)	Any unit
Unit -2	1 (a or b)	1 (a or b)	
Unit -3	1 (a or b)	1 (a or b)	
Unit -4	1 (a or b)	1 (a or b)	
Unit -5	1 (a or b)	1 (a or b)	

- Each short answer question carries 4 marks in section-A.
- Each long answer question carries 8 marks in section-B.
- Each essay answer question carries 10 marks in section-C.

The Question Paper Setters are requested to cover all the topics in the syllabus stipulated as per the weightage given by us.



**AG&SG SIDDHARTHA COLLEGE OF ARTS AND SCIENCE
VUYYURU
PG DEPARTMENT OF COMMERCE**

MODEL PAPER

CO305 - ADVANCED BANKING

Section - A (5 x 4 Marks = 20 Marks)

Answer the following Questions:

1. a) i. Credit control

(OR)

ii. Open market operation

b) i. federal reserve bank

(OR)

ii. Central board.

c) i. Commercial bank

(OR)

ii. Public sector bank

d) i. Economic stability

(OR)

ii. Price stability.

e) i. Home banking

(OR)

ii. IT Revolution

Section – B (5 x 8 Marks = 40 Marks)

Answer the following Questions:

2. a) What is meant by central bank? Explain the management of central bank in India.

(OR)

b) Techniques of credit control.



**AG&SG SIDDHARTHA COLLEGE OF ARTS AND SCIENCE
VUYYURU
PG DEPARTMENT OF COMMERCE**

3. a) Structure and organisation of central bank of India.

(OR)

b) Objectives of central banking of India and UK.

4. a) Recent Trends in banking sector.

(OR)

b) Explain the Asset Management.

5. a) Fiscal policy types.

(OR)

b) Explain the debt management policy.

6. a) Discuss the next Generation Banking.

(OR)

b) Emerging Trends in banking sector.

Section – C (1x10 Marks = 10 Marks)

Answer the following Question:

7 a) Discuss about the commercial bank in India.

(OR)

b) Central banking policy in developed and less developed countries.

==00==



**AG&SG SIDDHARTHA COLLEGE OF ARTS AND SCIENCE
VUYYURU
PG DEPARTMENT OF COMMERCE**

CO306 - INSURANCE AND RISK MANAGEMENT

Unit-I : Risk Management process – Risk Identification, Evaluation -Risk Management Techniques, Selecting and Implementing Risk Management Techniques – Types of Risks – Insurance and risk.

Unit-II : Commercial Liability Insurance – Commercial Risk Management Applications – Property –Liability – Commercial Property Insurance, Different policies and contracts – Business Liability and Risk Management – Workers compensation and Risk Financing.

UNIT-III : Property and liability Insurance Coverage – Personal Risk Management Applications–Property –Liability – Risk Management for Auto Owners – Risk Management for Home Owners.

UNIT-IV : Risk Management Applications – Loss of Life – Loss of Health – Retirement Planning and Annuities – Employee Benefits – Financial and Estate Planning.

UNIT-V : Risk Management Scenario- Functions and organisation of Insurers – Government Regulation of Insurance Sector – IRDA – Privatization of Insurance – Changes in Insurance Acts – Insurance Intermediaries – Insurance Product pricing and Claim valuation – Bank Assurance– Foreign Insurers in India.



AG&SG SIDDHARTHA COLLEGE OF ARTS AND SCIENCE
VUYYURU
PG DEPARTMENT OF COMMERCE

The Guidelines to be followed by the question paper setters in **CO306 - INSURANCE AND RISK MANAGEMENT** for the **third semester-end exams**

PAPER TITLE: CO306 - INSURANCE AND RISK MANAGEMENT

PAPER- VI Semester-III Maximum Marks: 70 Duration: 3 Hours

Weightage for the question paper

Syllabus	Section –A (Short answer questions) (with internal choice)	Section- B (Long answer questions) (with internal choice)	Section –C (Essay question) (with internal choice)
Unit -1	1 (a or b)	1 (a or b)	Any unit
Unit -2	1 (a or b)	1 (a or b)	
Unit -3	1 (a or b)	1 (a or b)	
Unit -4	1 (a or b)	1 (a or b)	
Unit -5	1 (a or b)	1 (a or b)	

- Each short answer question carries 4 marks in section-A.
- Each long answer question carries 8 marks in section-B.
- Each essay answer question carries 10 marks in section-C.

The Question Paper Setters are requested to cover all the topics in the syllabus stipulated as per the weightage given by us.



**AG&SG SIDDHARTHA COLLEGE OF ARTS AND SCIENCE
VUYYURU
PG DEPARTMENT OF COMMERCE**

MODEL PAPER

CO306 - INSURANCE AND RISK MANAGEMENT

Section - A (5 x 4 Marks = 20 Marks)

Answer the following Questions:

1. a i. Insurance and Risk
(OR)
ii. Types of Risk

- b i. Commercial Liability Insurance
(OR)
ii. Business Liability Insurance

- c i. Property Liability Insurance
(OR)
ii. Personal Liability Insurance

- d i. Loss of Life
(OR)
ii. Loss of Health

- e i. IRDA
(OR)
ii. Privatisation of Insurance

Section – B (5 x 8 Marks = 40 Marks)

Answer the following Questions:

2. a. Define Risk and Risk Management. Explain the Risk Management process.
(OR)
b. Explain the Techniques of Risk Management.

3. a. Explain the various Commercial Risk Management Applications
(OR)
b. Explain the concept of Workers compensation.



**AG&SG SIDDHARTHA COLLEGE OF ARTS AND SCIENCE
VUYYURU
PG DEPARTMENT OF COMMERCE**

4. a. How does the Property and liability Insurance Covered. Explain in detail.

(OR)

b. Give a detailed note about the Risk Management for Auto Owners.

5. a. Explain the concept of Retirement Planning.

(OR)

b. State the Employee Benefits in detail.

6. a. Explain the various Changes in Insurance Acts.

(OR)

b. Give a detailed note on Foreign Insurers in India.

Section – C (1x10 Marks = 10 Marks)

Answer the following Question:

7. a. Give a detailed note about Risk Financing.

(OR)

b. Explain the organisation and Functions of Insurers.

**AG & SG SIDDHARTHA DEGREE COLLEGE OF ARTS & SCIENCE
(AUTONOMOUS), VUYYURU.**

COOE301 - DISASTER MANAGEMENT

Unit-I: Disaster : Introduction, Types of Disaster – Natural and Manmade, Introduction, causes, important examples, effects, management. Blizzards – Introduction, causes, important, examples, effects, management.

Unit-II: Introduction, causes, important examples, effects, and management of famines, storms, cyclones, floods.

Unit-III: Introduction, causes, important examples, effects, and management of earthquakes, tsunamis, landslides.

Unit- IV: Introduction, causes, important examples, effects, and management of volcanic eruptions, lightning strikes, limnic eruption, wildfires/bushfires.

Unit- V: Introduction, causes, important examples, effects, and management of epidemics, mining, nuclear, chemical and biological.

The guidelines to be followed by the question paper setters in COM307 – DISASTER MANAGEMENT for the third semester - end exams.

PAPER TITLE: COOE301 - DISASTER MANAGEMENT

ELECTIVE PAPER

SEMESTER – III

Maximum Marks: 70

Duration: 3 Hours

Weightage for the question paper

Syllabus	Section –A (Short answer questions)	Section- B (Long answer questions) (with internal choice)
Unit -1	2	1 (a or b)
Unit -2	2	1 (a or b)
Unit -3	2	1 (a or b)
Unit -4	2	1 (a or b)
Unit -5	2	1 (a or b)

- Each short answer question carries 2 marks in section-A.
- Each long answer question carries 10 marks in section-B.

The Question Paper Setters are requested to cover all the topics in the syllabus stipulated as per the weightage given by us.

M.Com Degree Examination

Third Semester

Open Elective – Disaster Management

Time : 3 hours.

Maximum Marks : 70

SECTION – A

Answer **ALL** the questions. Each question carries 2 marks.

(10×2=20M)

1. What is a disaster? Give some examples of disaster.
2. Define various types of disasters.
3. Define Famines.
4. What are the causes of floods?
5. Give some examples for earthquakes.
6. How do landslides occur?
7. What is a limnic eruption?
8. How do volcanic eruptions occur?
9. Define epidemics.
10. What is a nuclear?

SECTION – B

(5×10=50M)

UNIT -I

11. a) What is disaster management? Write the importance of disaster management?

(or)

- b) Define Blizzards. How can we survive from blizzards?

UNIT - II

12. a) Write about various types of cyclones with suitable examples?

(or)

b) What causes floods? And what precautions we should take at the time of floods?

UNIT -III

13. a) Write the causes and effects of earthquakes?

(or)

b) What are the damages/effects occur during tsunamis? And what precautions should be taken during tsunamis?

UNIT - IV

14. a) Write about various types of volcanic eruptions? And give some examples of volcanic eruptions.

(or)

b) How do wildfires/bushfires occur? And what are the effects of wildfires?

UNIT - V

15.a) What safety measures should be followed during mining by the employees and organisation?

(or)

b) What are epidemics? What precautions should be taken to survive from epidemics?

**A.G& S.G.SIDDHARTHA DEGREE COLLEGE OF ARTS &
SCIENCE**

VUYYURU-521165, KRISHNA Dt., A.P.(Autonomous)

Accredited by NAAC with "A" Grade

2021-2022



DEPARTMENT OF COMMERCE (PG)

M.Com

MINUTES OF BOARD OF STUDIES

EVEN SEMESTER

24-03-2022



AG&SGS DEGREE COLLEGE OF ARTS AND SCIENCE
VJAYAWADA-10
(An Autonomous college under the jurisdiction of Krishna University)
 Reaccredited at the level 'A+' by the NAAC

DEPARTMENT OF COMMERCE

Minutes of Board of Studies Meeting (Online) of Department of Commerce for M.Com held on 24/03/2022, Monday at 10.00 AM. The following members were present.

Members Present		
Name of the Member	Role	Signature
Dr. T.Venkateswara Rao HOD Department of Commerce Mobile No: 9848726150/9491737921	Chairman	
Dr. R. Padmaja, Assistant Professor in Business Management, Krishna University, Machilipatnam. Mobile: 9440532444,	University Nominee	
Dr.R. Siva Ram Prasad. Santha Kumari, Professor, Dean Department of Commerce & Business Administration Acharya Nagarjuna University, Nagarjuna Nagar, Guntur Mobile No: 9849856589	Subject Expert	
Prof. Rajesh C Jampala Dean Department of Commerce & Business Management PBS College of Arts & Science, Vijayawada. Mobile No: 9866806069	Subject Expert	
Sai Babu, Vuyyuru	Alumnus	
Sri V.V. Punna Rao General Manager KCP Sugar Pvt., Ltd, Vuyyuru. Mobile No: 9704456972	Industry Expert	
Kum Mohana Krishna Department of Commerce (PG) AG&SGS Degree College of Arts & Science, Vuyyuru	Member	
Y. Swarna Latha Department of Commerce (PG) AG&SGS Degree College of Arts & Science,	Member	
G. Kiran Kumar Department of Commerce (PG) AG&SGS Degree College of Arts & Science, Vuyyuru	Member	

**Agenda for Board of Studies meeting for the
Master of Commerce (M.Com)
PGDepartment of Commerce**

To evaluate and recommend Programme Structure for Master of Commerce program (M.Com) under CBCS for the students admitted in the academic year 2021-2022.

1. To explore the possibility of new courses or combination of courses.
2. To assess the potential of the courses against the employment prospects.
3. To assess the compatibility of practical courses with theory courses.
4. To approve the structure of Model Question Papers with COs and for all courses of II & IV semesters of M.Com.
5. To approve the list of examiners and paper setters of all the courses.
6. To approve the course outcomes (COs) for all the courses of II & IV (EVEN) Semesters of M.Com.
7. Any other matter with the permission of the chair.

RESOLUTIONS

- i. Discussed the Syllabi of II and IV Semesters of M.Com, with **Dual Specialisation in 1. Accounting & Taxation 2. Banking, Insurance & Finance** for the approval of the BOS.

They recommended to continue the same Course Structure designed by me with **Single specialisation** as lack of required strength to adopt **Dual Specialisation** (and the syllabi of II and IV Semesters of M.Com, is nearest to the KRU Syllabus and also to avoid confusion in the students due to least strength of 13 in numbers and there is no I Year Students).

- ii. Discussed and recommended to continue **MOOCs**.
- iii. Discussed and recommended to conduct **Comprehensive Seminar** (Internal Assessment for 50 marks with 2 Credits).
- iv. Discussed and recommended the following teaching and evaluation methods for the approval of BOS.

Teaching Methods:

Besides the conventional methods of teaching, we use modern technology i.e., using of LCD projector to display on U boards and online teaching etc., for better understanding of concept.

Evaluation of student is done by the following procedure:

- i. Out of maximum 100 marks in each paper, 30 marks shall be allocated for internal assessment.
- ii. Out of 30 marks, 20 marks are allocated for announced internal tests. Two announced internal tests will be conducted and average of these Two tests shall be deemed as the marks obtained by the students, out of 10 marks 5 marks are allocated to Assignments, Seminars and Online Exam and remaining 5 marks are allocated to candidate's percentage of attendance.

445

Semester-End Examinations:

- i. The maximum marks for Semester-End Examinations shall be 70 marks and duration of the examination shall be 3 Hours.
 - ii. Semester-End Examinations shall be conducted in theory papers at the end of every Semester.
-
- v. Discussed and recommended for organising National seminars, Guest Lectures, Work-shops to upgrade the knowledge of students, for the approval of the BOS.
 - vi. Discussed and empowered the H.O.D. to suggest the panel of paper setters and Examiners to the Controller of Examinations.

CHAIRMAN



(Dr. T. Venkateswara Rao)

M.Com:

PSOs:

PSO1: To provide an opportunity for graduates to acquire theoretical as well as practical inputs in commerce to enter a career in professional areas of commerce and finance such as taxation, consultancy and financial services.

PSO2: To develop advanced theoretical knowledge and research capabilities to able to pursue academic and research focused careers.

POs:

PO1: Business Environment and Domain Knowledge (BEDK): Economic, legal and social environment of Indian business. Graduates are able to improve their awareness and knowledge about functioning of local and global business environment and society. This helps in recognizing the functioning of businesses, identifying potential business opportunities, involvement of business enterprises and exploring the entrepreneurial opportunities.

PO2: Critical thinking, Business Analysis, Problem Solving and Innovative Solutions (CBPI): Competencies in quantitative and qualitative techniques. Graduates are expected to develop skills on analyzing the business data, application of relevant analysis, and problem solving in other functional areas such as marketing, business strategy and human resources.

PO3: Global Exposure and Cross-Cultural Understanding (GECCU): Demonstrate a global outlook with the ability to identify aspects of the global business and Cross Cultural Understanding.

PO4: Social Responsiveness and Ethics (SRE): Developing responsiveness to contextual social issues/ problems and exploring solutions, understanding business ethics and resolving ethical dilemmas. Graduates are expected to identify the contemporary social problems, exploring the opportunities for social entrepreneurship, designing business solutions and demonstrate ethical standards in organizational decision making. Demonstrate awareness of ethical issues and can distinguish ethical and unethical behaviours.

PO5: Effective Communication (EC): Usage of various forms of business communication, supported by effective use of appropriate technology, logical reasoning, articulation of ideas. Graduates are expected to develop effective oral and written communication especially in business applications, with the use of appropriate technology (business presentations, digital communication, social network platforms and so on).

PO6: Leadership and Teamwork (LT): Understanding leadership roles at various levels of the organization and leading teams. Graduates are expected to collaborate and lead teams across organizational boundaries and demonstrate leadership qualities, maximize the usage of diverse skills of team members in the related context.

PO7: Knowledge Application (KA): Acquire knowledge in different areas of management such as finance, marketing, accounting, human resource and operations and apply quantitative techniques such as operations research, statistical methods, financial models, econometrics for making informed business decisions in organizations.

APPENDIX – I

Scheme of Instruction and Evaluation for M.Com. Programme for the batch of students admitted during 2021-22 and onwards.

SEMESTER – II								
CO211	Financial Accounting & Packages	4	1	1	4	30	70	3 Hrs.
CO212	Financial Management	4	1	1	4	30	70	3 Hrs.
CO213	Human Resources Management	4	1	1	4	30	70	3 Hrs.
CO214	Marketing Management	4	1	1	4	30	70	3 Hrs.
CO215	Business Research Methods	4	1	1	4	30	70	3 Hrs.
CO216	E-Commerce	4	1	1	4	30	70	3 Hrs.
Generic Elective Courses (Choose any one out of three Courses)								
GE01	Excel & Tally Practical's	1	1	1	2	50	-	-
GE02	Human Values & Ethics	1	1	1	2	50	-	-
GE03	Personality Development Lab	1	1	1	2	50	-	-

CIA = Continuous Internal Assessment; SEE = Semester End Examinations

Note: Course Codes will be allotted by the Examination Section.

IV SEMESTER

Sl. No.	Title of the Course	Instruction Hours per week			Credits	Evaluation		
		L	T	P		CIA Marks	SEE	
							Marks	Duration
Generic Core Courses								
411	Project Planning and Control	4	1	1	4 ✓	30	70	3 Hrs.
412	International Business	4	1	1	4 ✓	30	70	3 Hrs.
413	MOOCS – Organisational Behaviour	4	1	1	4 ✓	30	70	3 Hrs.
FUNCTIONAL SPECIALISATIONS								
From the following three specialization areas choose any one specialization area of your choice :								
1. Accounting & Taxation 2. Banking, Insurance & Finance 3. International Business								
Accounting & Taxation								
421	Advanced Management Accounting	4	1	1	4	30	70	3 Hrs.
422	Auditing & Assurance	4	1	1	4	30	70	3 Hrs.
423	GST & Customs	4	1	1	4	30	70	3 Hrs.
424	Corporate Tax Planning & Management	4	1	1	4	30	70	3 Hrs.
Banking, Insurance & Finance								
431	International Banking	4	1	1	4 ✓	30	70	3 Hrs.
432	Financial Services	4	1	1	4 ✓	30	70	3 Hrs.
433	Banking and Technology	4	1	1	4 ✓	30	70	3 Hrs.
434	Insurance Products and Management	4	1	1	4 ✓	30	70	3 Hrs.
International Business								
441	Foreign Exchange and Risk Management	4	1	1	4	30	70	3 Hrs.
442	Global Logistics & Supply Chain Mgt.	4	1	1	4	30	70	3 Hrs.
443	International Business Negotiations	4	1	1	4	30	70	3 Hrs.
444	India's Foreign Trade & Documentation	4	1	1	4	30	70	3 Hrs.
451	Comprehensive Viva-Voce	-	-	-	4	-	100	
452	Comprehensive Seminar	-	-	-	2	50		

AG&SG SIDDHARTHA DEGREE COLLEGE OF ARTS & SCIENCE VUYYURU

(An Autonomous college under the jurisdiction of Krishna University)

Reaccredited at the level 'A' by the NAAC

A.G&S.G .Siddhartha Degree College of Arts & Science-Vuyyuru- 521165			
List of Paper Setters			
Subject Name: Business Law	Course: M.Com.	Course Code: CO211	Department: Commerce (PG)
1. . Mrs.B.Kalpna Assistant Professor Department of Commerce & Business Administration, P.B Siddhartha College of Arts & Science Vijayawada. Mobile No. 7842669134		2. Dr. B. Sankhar Babu, Assistant Professor, Department of Commerce, P.B Siddhartha College of Arts & Science Vijayawada Mobile No.: 9346487036	

A.G&S.G .Siddhartha Degree College of Arts & Science-Vuyyuru- 521165			
List of Paper Setters			
Subject Name: Financial Management	Course: M.Com	Course Code: CO212	Department:Commerce (PG)
1. Dr. P.D M. Raju Professor, Department of Commerce Prabhas College, Vijayawada. Mobile No. 9440751609		2. . Dr. B. Sankhar Babu, Assistant Professor, Department of Commerce, P.B Siddhartha College of Arts & Science Vijayawada Mobile No.: 9346487036	

A.G&S.G .Siddhartha Degree College of Arts & Science-Vuyyuru- 521165

List of Paper Setters

Subject Name: Human Resources Management	Course: M.Com	Course Code: CO213	Department:Commerce (PG)
1. Mrs. A. Siva Naga Lakshmi, Assistant Professor Department of Commerce & Business Administration P.B Siddhartha College of Arts & Science Vijayawada.		2 Mrs.G.Lalitha Madhavi Assistant Professor Department of Commerce & Business Administration P.B Siddhartha College of Arts & Science Vijayawada. Mobile No.: 7799209460	

A.G&S.G .Siddhartha Degree College of Arts & Science-Vuyyuru- 521165

List of Paper Setters & External Examiners

Subject Name: Marketing Management	Course: M.Com	Course Code: CO214	Department:Commerce (PG)
1. Mrs.B.Kalpana Assistant Professor Department of Commerce & Business Administration, P.B Siddhartha College of Arts & Science Vijayawada. Mobile No. 7842669134		2. P. Padmanabam Assistant Professor Department of Commerce, SRR & CVR College, Vijayawada.	

A.G&S.G .Siddhartha Degree College of Arts & Science-Vuyyuru- 521165

List of Paper Setters & External Examiners

Subject Name: Business analytics and Research Methods	Course: M.Com	Course Code: CO215	Department:Commerce (PG)
---	---------------	--------------------	--------------------------

1. Dr.B.Jaya Prakash,
Associate Professor, Deputy Head,
Department of Commerce & Business
Administration
P.B Siddhartha College of Arts & Science
Vijayawada.
Mobile No. 9849813969

2 Dr. P.D M. Raju
Professor,
Department of Commerce
Prabhas College,
Vijayawada.
Mobile No. 9440751609

A.G&S.G .Siddhartha Degree College of Arts & Science-Vuyyuru- 521165

List of Paper Setters & External Examiners

Subject Name: E-commerce	Course: M.Com	Course Code: CO216	Department: Commerce (PG)
--------------------------	---------------	--------------------	---------------------------

1. . Mrs. A. Siva Naga Lakshmi,
Assistant Professor
Department of Commerce & Business
Administration
P.B Siddhartha College of Arts & Science
Vijayawada.

2. M J Rajpaul,
Assistant Professor
Department of Commerce,
SRR & CVR College,
Vijayawada.
Mobile No. 9502093357

Course structure and scheme of Teaching and Examination

Master of Commerce

I SEMESTER

Paper Code	Paper Title	Teaching Hours/ week		Core / Elective	Internal Marks	External Marks	No. of Credits
		Lecture	Tutorial/ Practical				
CO111	Management theory and practice	5	1	Core	30	70	5
CO112	Business Economics	5	1	Core	30	70	5
CO113	Business Environment	5	1	Core	30	70	5
CO114	Entrepreneurship Development	5	1	Core	30	70	5
CO115	Information Technology for Business	5	1	Core	30	70	5
CO116	Quantitative Techniques for Business decisions	5	1	Core	30	70	5

II SEMESTER

Paper Code	Paper Title	Teaching Hours/ week		Core / Elective	Internal Marks	External Marks	No. of Credits
		Lecture	Tutorial/ Practical				
CO211	Business Law	5	1	Core	30	70	5
COM212	Financial Management	5	1	Core	30	70	5
COM213	Human Resources Management	5	1	Core	30	70	5
COM214	Marketing Management	5	1	Core	30	70	5
COM215	Business analytics and Research Methods	5	1	Core	30	70	5
COM216	E-commerce	5	1	Core	30	70	5
GE02	CBCS Paper -1	3	1	Elective	50	--	3

AG&SG SIDDHARTHA DEGREE COLLEGE OF ARTS & SCIENCE VUYURU

(An Autonomous college under the jurisdiction of Krishna University)

Reaccredited at the level 'A' by the NAAC

Business Laws

Subject Code :	CO201	I A Marks	30
No. of Lecture Hours / Week	05	End Exam Marks	70
Total Number of Lecture Hours	75	Total Marks	100
Practical Component	01 Hour/Week	Exam Hours	03

Course Outcomes: By the end of the course, students will be able:

CO-1 To provide knowledge and understanding nature of the company and how to conduct the board meetings , appointment of the directors

CO-2 To know about how to prevent the money laundering in the business

CO-3 To provide expert knowledge on how to protect consumers and also provide the knowledge about to Right to Information Act

CO-4 To provide expert knowledge on Information Technology Act

CO-5 To know about the powers and freedom of corporate and business ethics

Unit –I

Companies Act 2013: Definition and Nature of Company - Incorporation of company – Prospectus - Shares and Debentures - Acceptance of Deposits - Appointment and Qualification of Directors - Meetings of Boards and its powers - Inspection and investigation - Compromises, arrangements and amalgamations - Prevention of oppression and Mismanagement - SEBI Act, 1992

Unit- II

Depositories Act, 1996 – Prevention of Money Laundering Act, 2002.

Unit- III

Consumer Protection Act, 1986 – Competition Act, 2002 – Environment Protection Act – Right to Information Act, 2005

Unit –IV

Foreign Exchange Management Act, 1999- Cyber laws-Information Technology Act, 2000.

Unit – V

Corporate Governance and Business Ethics – Ethical practices and guidelines: Internal to the Organization –Power and freedom: External to the organization.

References

1. Bulchandani RR : Business Law, Himalaya Publishing House.
2. SC Kuchal: Business Law, Vikas publishing House.
3. Agarwal UK : Consumer Protection in India (Deep & Deep)
4. Gulshan SS : Business Law (Excel)
5. Bare Acts

The Guidelines to be followed by the question paper setters in BUSINESS LAW for the second semester-end exams

PAPER TITLE: BUSINESS LAWS

PAPER-I Semester-II Maximum Marks: 70 Duration: 3 Hours

Weightage for the question paper

Syllabus	Section –A (short answer questions) (with internal choice)	Section- B (Long answer questions) (with internal choice)	Section –C (essay question) (with internal choice)
Unit -1	1 (a or b)	1 (a or b)	Any unit
Unit -2	1 (a or b)	1 (a or b)	
Unit -3	1 (a or b)	1 (a or b)	
Unit -4	1 (a or b)	1 (a or b)	
Unit -5	1 (a or b)	1 (a or b)	

- Each short answer question carries 4 marks in section-A.
- Each long answer question carries 8 marks in section-B.
- Each essay answer question carries 10 marks in section-C.

The Question Paper Setters are requested to cover all the topics in the syllabus stipulated as per the weightage given by us.

AG&SG SIDDHARTHA DEGREE COLLEGE OF ARTS & SCIENCE VUYYURU

(An Autonomous college under the jurisdiction of Krishna University)

Reaccredited at the level 'A' by the NAAC

MODEL QUESTION PAPER

M.COM. (REGULAR) DEGREE EXAMINATION

Second Semester

BUSINESS LAWS

(2017-2018 Regulation Onwards)

Duration: 3 hours

Maximum Marks: 70

SECTION- A

Answer the Following Questions

5×4=20 Marks

1. a. (i) Compromises.

(OR)

(ii) Debentures.

b. (i) Objectives of Deposition Act, 1926

(OR)

(ii) Scope of prevention of money laundering act 2002.

c. (i) complaints

(OR)

(ii) Information exchange.

d. (i) Fintech

(OR)

(ii) Foreign policy

e. (i) Corporate governance.

(OR)

(ii) Code of conduct

SECTION – B

Answer All Questions

5×8=40Marks

2. a) Discuss the prevention of the companies act 1950. Is regard to removal of directors by the Central Government?

(Or)

- b) Define a manager and distinguish between a manager, managing director and a whole-time direction.

3. a) What is money laundering? Discuss how money laundering takes place?

(Or)

- b) Explain how is a depository similar to a bank?

4. a) Explain the objectives and main provisions of Competition Act 2002.

(Or)

- b) Explain the Right to Information Act 2005 in detail.

5. a) discuss the applicability and overall structure of FEMA Act 1999.

(Or)

- b) State and explain the digital signatures, digital certificates and R.S.A algorithm

6. a) what do you understand by the term “Corporate Governance” ? Why is it important?

(Or)

- b) Explain in detail the ethical practices by business in India.

SECTION C

Answer the following question.

(1 x 10=10 marks)

7. a) Explain briefly important clauses of Memorandum of Associations of a Company?

(Or)

- b) Explain Information Technology Act, 2000.

FINANCIAL MANAGEMENT

Subject Code :	CO202	I A Marks	30
No. of Lecture Hours / Week	05	End Exam Marks	70
Total Number of Lecture Hours	75	Total Marks	100
Practical Component	01 Hour/Week	Exam Hours	03

Course Outcomes: By the end of the course, students will be able:

- CO 1 To understand the perspective on financial management function in the company and in its relation to domestic and international economy.
- CO 2 To provide illustration on financial management practices and policies, processes, techniques and strategies those are used in the financial management.
- CO 3 To develop knowledge on the type and characteristics of problems and the possibility of the occurrence of financial management problems,
- CO 4 To develop planning skill and monitoring skill in financial management functions effectively.
- CO 5 To apply the appropriate working capital management strategy to face the company challenges.

Unit-I: Introduction: Nature, Scope and Objectives of Financial Management: Finance Function–Profit Goal vs. Wealth Goal Maximization - Financial Manager in Modern business Organizations (Theory)

Unit-II: Investment decision: Capital Budgeting process –Methods of appraisal: Traditional Techniques and Discounted Cash Flow Methods – NPV vs. IRR - Capital rationing (Theory & problems)

Unit-III: Financing decisions: Concept of leverage – Types of Leverages –EBIT – EPS Analysis – Capital Structure – Theories of Capital Structure – Net Income approach – Net Operating income approach – Traditional view – MM Hypothesis Cost of Capital: Types of Cost of Capital - Weighted average Cost of capital. Capital Structure Determinants.(Theory & problems)

Unit-IV: Dividend decisions: Kinds of dividends, Dividend Policy types, Dividend Theories – Walter’s Model – Gordon’s Model – M-M Hypothesis (Theory & problems)

Unit-V: Working Capital Management: Meaning, Significance, Types of Working capital, Determinants of working capital, and Methods of Measuring working Capital Requirements - Operating cycle -Financing of Working Capital-Management of Cash, Receivables, and Inventory (Theory & problems)

References

1. Chandra Bose D., Fundamentals of Financial Management, 2nd Edition (2006) Prentice Hall of India.
2. Khan M Y and Jain P. K., Basic Financial Management: Text and Problems, 2nd Edition (2005) Tata McGraw Hill.
3. Pandey I M., Financial Management, 11th Edition (2015) Vikas Publishing House Pvt. Ltd.
4. .Pandey & Bhat, Cases in Financial Management, 2nd Edition (2000) Tata McGraw Hill.
5. Prasanna Chandra, Financial Management - Theory and Practice, 10th Edition (2019) Tata McGraw Hill.

The Guidelines to be followed by the question paper setters in FINANCIAL MANAGEMENT for the second semester-end exams

PAPER TITLE: FINANCIAL MANAGEMNT

PAPER-II Semester-II Maximum Marks: 70 Duration: 3 Hours

Weightage for the question paper

Syllabus	Section –A (short answer questions) (with internal choice)	Section- B (Long answer questions) (with internal choice)	Section –C (essay question) (with internal choice)
Unit -1	1 (a or b)	1 (a or b)	Any unit
Unit -2	1 (a or b)	1 (a or b)	
Unit -3	1 (a or b)	1 (a or b)	
Unit -4	1 (a or b)	1 (a or b)	
Unit -5	1 (a or b)	1 (a or b)	

- Each short answer question carries 4 marks in section-A.
- Each long answer question carries 8 marks in section-B.
- Each essay answer question carries 10 marks in section-C.

The Question Paper Setters are requested to cover all the topics in the syllabus stipulated as per the weightage given by us.

MODEL QUESTION PAPER
M.COM. (REGULAR) DEGREE EXAMINATION
Second Semester
FINANCIAL MANAGEMENT
(2017-2018 Regulation Onwards)

Duration: 3 hours

Maximum Marks: 70

SECTION- A

Answer Any Five of the Following Questions

5×4=20Marks

1. Write short notes on:

a. (i) Financing function.

(OR)

(ii) NPV method

b. (i) Operating leverage

(OR)

(ii) Cost of equity

c. (i) WACC

(OR)

(ii) Operating cycle

d. (i) Gross VS Net working capital

(OR)

(ii) Kinds of dividends

e. (i) Objectives of Financial Management

(OR)

(ii) Significance of Working Capital Management.

SECTION – B

Answer All Questions 5×8=40Marks

2. a) Discuss in detail, the scope of Financial Management.

(OR)

b) Do you support the concept of Profit Maximization or Wealth Maximization? Give Reasons.

3. a) What is Capital Budgeting? Explain briefly about techniques of Capital Budgeting?

(OR)

b) A company is considering an investment proposal to install new machine at a cost of Rs.50, 000/-. The machine will last for 5 years and has no salvage value. The estimated cash flows after taxes are:

Years	1	2	3	4	5
Estimated Cash flows after taxes (Rs.)	10,000	10,450	11,800	12,250	16,750

Compute the following :

a) Pay-Back period b) Average rate of Return c) NPV at 10% d) IRR

4 .a) Explain Net Income and Net Operating Income approach of capital structure theories.

(OR)

b) A firm forecasts that it will produce 15, 00 units and generate EBIT of Rs. 3, 00,000. The DOL for a quantity level of 15,000 units is 2.5. There is a possibility that the actual output could range from 10% below to 5% above the forecast value. Calculate the range of possible forecast errors for EBIT in % terms and also corresponding EBIT values.

5. a) Show the implications of dividend policy according to Gordon's Model for the give information:

Particulars	Growth Firm	Normal Firm	Declining Firm
r	15%	10%	8%

All the firms have $k=0.10$ and $EPS= Rs 10$. Show the values when the firms adopt 40% and 60% pay-out ratio.

(OR)

b) What is the substance of Miller and Modigliani 'dividend irrelevance' theorem?

6. a) Explain the concept of working capital and the factors that determine the working capital needs of the firm.

(OR)

b) A cost sheet of a company provides the following data:

Particulars	Cost per unit Rs
Raw Material	52
Direct labour	19.5
Overheads	39
Total Costs	110.5
Profit	19.5
Selling Price	130

The following is the additional information available:

Average raw material in stock: one month;
 Average materials in process: half month
 Credit allowed by suppliers: one month
 Credit allowed to debtors: two month;
 Time Lag in payment of wages: one and a half weeks.
 Overheads: one month.
 One fourth of sales are on cash basis.

Cash balance is expected to be Rs. 1, 20,000. You are required to prepare a statement showing the working capital needed to finance a level of activity of 70,000 units of output. Assume that production is carried on evenly throughout the year and wages and overheads accrue similarly.

SECTION C

Answer the following question.

(1 x 10=10 marks)

7. a) A company is considering an investment proposal to install new machine at a cost of Rs.50, 000. The machine will last for 5 years and has no salvage value. The estimated cash flows after taxes are:

Year	Estimated Cash flows after taxes
1	Rs. 10,000
2	Rs.10,450
3	Rs. 11,800
4	Rs. 12,250
5	Rs. 16,750

Compute the following:

- Payback period
- Average rate of return
- Internal rate of return
- Net present value at 10%

(OR)

b) Explain about various dividend theories.

AG&SG SIDDHARTHA DEGREE COLLEGE OF ARTS & SCIENCE VUYYURU

(An Autonomous college under the jurisdiction of Krishna University)

Reaccredited at the level 'A' by the NAAC

HUMAN RESOURCE MANAGEMENT

Subject Code :	CO203	I A Marks	30
No. of Lecture Hours / Week	05	End Exam Marks	70
Total Number of Lecture Hours	75	Total Marks	100
Practical Component	01 Hour/Week	Exam Hours	03

Course Outcomes: By the end of the course, students will be able:

- CO-1 To cover the basic concepts of Human Resource management.
- CO-2 To contribute the development of human resource planning, implementation, and evaluation of employee recruitment, selection, and retention plans and processes)
- CO-3 To develop, implement, and evaluate employee orientation, training, and development programs
- CO-4 To administer and contribute to the design and evaluation of the performance management program
- CO-5 To develop the students' ability to learn concepts like compensation, employee welfare, and industrial relation issues

Unit- I: Human Resource Management: Nature and significance, functions of HRM, Qualities and Role of HR Manager, HRM Model, HRM in a changing Environment.

Unit-II: Human Resource Planning: Objectives, process, factors affecting HR Planning, Requisites for successful HR Planning, Recruitment – Factors influencing, Sources of Recruitment – E- Recruitment-Selection Process – Placement, induction and Socialization – Promotion and Transfers

Unit-III: Employee Training: Significance – Identification of Training Needs – Employee Training Methods – Executive Development Methods – Evaluation of Training and Development Programs – Methods of Evaluation -Limitations to its effectiveness

Unit-IV: Performance Appraisal: Scope & Significance – Methods of Appraisal – Limitations of Appraisal - Career Planning and Development – Counseling- Mentoring-Coaching

Unit – V:Wage and Salary Administration: Wage Structure and Policy – Wage Differentials – Wage Payment Methods – Incentives – Fringe Benefits –Industrial Relations: Causes of Disputes and Settlement - Role of State in Industrial Relations - Collective Bargaining -Employee Participation in Management - Quality of Work Life.

References:

1. Aswathappa. Human Resource Management 6thEdition (2010). Tata McGraw Hill, New Delhi.
2. Biswanath Ghosh. Human Resource Development and Management, (2005) Jain Book Depot , New Delhi
3. C. B. Mamoria. Personnel management 21stEdition (2012). Himalaya Publishing House , New Delhi:
4. Edwin Flippo. Personnel management 5thEdition (1994). Tata McGraw Hill, New Delhi.
5. Rajashree Shinde, A. Abhilasha, A. Ramakumar Human Resource Management 1st Edition (2017). Himalaya Publishing House, New Delhi.
6. Sahni Personnel Management 5th Edition (2005). Kalyani Publisher, New Delhi.
7. SubbaRao. Human Resources management 12thEdition (2011). Himalaya Publishing House, New Delhi.
8. V. S. P. Rao, Human Resources Management, 3rd Edition (2010). Excel Books, New Delhi.

The Guidelines to be followed by the question paper setters in HUMAN RESOURCE MANAGEMNT for the second semester-end exams

PAPER TITLE: HUMAN RESOURCE MANAGEMNT

PAPER-III Semester-II Maximum Marks: 70 Duration: 3 Hours

Weightage for the question paper

Syllabus	Section –A (short answer questions) (with internal choice)	Section- B (Long answer questions) (with internal choice)	Section –C (essay question) (with internal choice)
Unit -1	1 (a or b)	1 (a or b)	Any unit
Unit -2	1 (a or b)	1 (a or b)	
Unit -3	1 (a or b)	1 (a or b)	
Unit -4	1 (a or b)	1 (a or b)	
Unit -5	1 (a or b)	1 (a or b)	

- Each short answer question carries 4 marks in section-A.
- Each long answer question carries 8 marks in section-B.
- Each essay answer question carries 10 marks in section-C.

The Question Paper Setters are requested to cover all the topics in the syllabus stipulated as per the weightage given by us.

AG&SG SIDDHARTHA DEGREE COLLEGE OF ARTS & SCIENCE VUYYURU

(An Autonomous college under the jurisdiction of Krishna University)

Reaccredited at the level 'A' by the NAAC

MODEL QUESTION PAPER

M.COM. (REGULAR) DEGREE EXAMINATION

Second Semester

HUMAN RESOURCE MANAGEMENT

(2017-2018 Regulation Onwards)

Duration: 3 hours

Maximum Marks: 70

SECTION- A

Answer Any Five of the Following Questions

5×4=20 Marks

1. Write Short Notes on:

a. (i) Role of HRM

(OR)

(ii) Human Resource planning.

b. (i) Vestibule Training.

(OR)

(ii) Career planning.

c. (i) Quality of Work Life.

(OR)

(ii) Fringe benefits.

d. (i) E-Recruitment

(OR)

(ii) HRM Model.

e. (i) Sources of Recruitment.

(OR)

(ii) Wage Payment Methods.

SECTION – B

Answer All Questions

5×8=40Marks

2. a) Define Human Resource Management and discuss the objectives and functions of HRM.

(Or)

b) Explain the role of HRM in the changing environment.

3. a) What is human resource planning? Analyze various steps in the process of human resource Planning.

(Or)

b) Explain the Sources Recruitment with relevant merits and limitations

4. a) Identify the employee training methods.

(Or)

b) Show the Importance of training and Distinguish between employee training and executive development.

5. a) Discuss the methods of performance appraisal.

(Or)

b) Examine the Significance and limitations of Performance appraisal.

6.a) Define the concept wage and salary administration. Explain the wage payment methods.

(Or)

b) Evaluate the Methods of Employee participation in management.

SECTION C

Answer the following question.

(1 x 10=10marks)

7. a) what is meant by the term Industrial Disputes? Discuss its causes and settlement mechanism.

(Or)

b) Define HRM. Explain the nature, scope& significance of HRM.

AG&SG SIDDHARTHA DEGREE COLLEGE OF ARTS & SCIENCE VUYYURU

(An Autonomous college under the jurisdiction of Krishna University)

Reaccredited at the level 'A' by the NAAC

MARKETING MANAGEMENT

Subject Code :	CO204	I A Marks	30
No. of Lecture Hours / Week	05	End Exam Marks	70
Total Number of Lecture Hours	75	Total Marks	100
Practical Component	01 Hour/Week	Exam Hours	03

Course Outcomes: By the end of the course, students will be able:

- CO-1 Understand the concepts of marketing and to know the changing context of marketing environment.
- CO-2 Appreciating the knowledge of consumer behaviour in implementing the marketing strategies to satisfy target customer and also distinguish between Marketing Information System and Market Research.
- CO-3 Conceptual understanding of product management and issues relating with marketing of services.
- CO-4 Understand different price strategies and the dynamics of channel management.
- CO-5 Be able to know the elements of promotion mix and the importance of integrated marketing communications.

Unit-I: Marketing-Concepts-Approaches to the Study of Marketing – Functions of Marketing-Marketing Environment.

Unit-II: Consumer Behavior – Factors affecting Consumer Behavior- Market Segmentation – Market Targeting and Positioning – Marketing Information System and Marketing Research.

Unit-III: Marketing Mix: Product Planning – New Product Development – Product Life Cycle– Branding &Packaging – Product line- Product Mix Management- Product Vs Service.

Unit-IV: Pricing and Distribution: Pricing Objectives – Methods and Strategies ; Channels of distribution – Channel Selection and Management -Retail Management.

Unit-V: Promotion: Promotion Mix-Personal Selling-Advertising - Sales Promotion, Publicity and Public Relations – Direct Marketing; Promotional strategies- Web Marketing – Integrated Marketing Communications.

References

1. Aparna Tembulkar, Marketing Management, 2nd Edition. (2014) Nirali Prakashan, Pune.
2. Kazmi S H, marketing Management: Text and Cases, 1st Edition, (2007), Excel Books, New Delhi.
3. Philip Kotler, Kevin Lane Keller, Marketing Management –Global Edition, 15th Edition. (2016) Pearson India Education Services Pvt Ltd.
4. Rajan Suksena, Marketing Management, 5th Edition.(2017) McGraw Hill Education (India) Private Limited.
5. Ramaswamy, Namakumari, Marketing Management: planning, Implementation & Control, 6th Edition, (2018), Sage Publisher, New Delhi.
6. Sherlekar S.A, Marketing Management, 13th Edition, (2008), Himalaya Publishing House, Mumbai.

The Guidelines to be followed by the question paper setters in
 MARKETING MANAGEMENT for the second semester-end exams

PAPER TITLE: MARKETING MANAGEMNT

PAPER-IV Semester-II Maximum Marks: 70 Duration: 3 Hours

Weightage for the question paper

Syllabus	Section –A (short answer questions) (with internal choice)	Section- B (Long answer questions) (with internal choice)	Section –C (essay question) (with internal choice)
Unit -1	1 (a or b)	1 (a or b)	Any unit
Unit -2	1 (a or b)	1 (a or b)	
Unit -3	1 (a or b)	1 (a or b)	
Unit -4	1 (a or b)	1 (a or b)	
Unit -5	1 (a or b)	1 (a or b)	

- Each short answer question carries 4 marks in section-A.
- Each long answer question carries 8 marks in section-B.
- Each essay answer question carries 10 marks in section-C.

The Question Paper Setters are requested to cover all the topics in the syllabus stipulated as per the weightage given by us.

MODEL QUESTION PAPER
M.COM. (REGULAR) DEGREE EXAMINATION
Second Semester
MARKETING MANAGEMENT-CO204
(2017-2018 Regulation Onwards)

Duration: 3 hours

Maximum Marks: 70

SECTION- A

Answer Any Five of the Following Questions

5×4=20 Marks

1. Write short notes on:

- (a) (i) Product vs Service.
(OR)
(ii) Targeting
- (b) (i) Marketing Information System
(OR)
(ii) Channel Conflict
- (c) (i) Integrated Marketing Communication
(OR)
(ii) Psychological Pricing
- (d) (i) Global Marketing
(OR)
(ii) Positioning.
- (e) (i) Functions of Marketing.
(OR)
(ii) Pricing Objectives.

SECTION – B

Answer All Questions

5×8=40Marks

2. a) Differentiate between sales and marketing. What are the core concepts of marketing?
(Or)
b) What are the elements of marketing environment? Explain their influence on marketing.
3. a) Define Marketing Research. Explain various steps involved in Marketing Research.
(Or)
b) Define Market Segmentation. What are the types of Market Segmentation? Explain them briefly.

4. a) What is meant by Product Life Cycle? Explain the stages of Product Life Cycle with Suitable illustration.
(Or)
b) Define Brand. What are the various Brand strategies?
5. a) Explain the objectives of Pricing. What are the various price adjustment strategies?
(Or)
b) What factors are to be considered in the selection of Channel Members? Explain the Channel selection criteria.
6. a) Describe the role of 'Web Marketing' in present day business context.
(Or)
b) Define 'Sales Promotion'. What are the sales promotion techniques followed by marketing companies? Explain with suitable examples.

SECTION - C

Answer the following question.

(1 x 10=10 marks)

7. a) Define 'Consumer Behaviour' .Explain various factors influencing Consumer Behaviour.
(Or)
b) Define 'Advertising'. Explain its role in promotion of fast moving consumer goods.

BUSINESS ANALYTICS AND RESEARCH METHODS

Subject Code :	CO205	I A Marks	30
No. of Lecture Hours / Week	05	End Exam Marks	70
Total Number of Lecture Hours	75	Total Marks	100
Practical Component	01 Hour/Week	Exam Hours	03

Course Outcomes: By the end of the course, students will be able:

- CO-1 To understand basic concepts of research and formulate research problems and process.
- CO-2 To generate an awareness of research design and data collection methods.
- CO-3 To develop and understand of sampling design and techniques.
- CO-4 To understand how to analyse and interpretation of the data.
- CO-5 To provide expert knowledge about to write a research report and thesis.

Unit –I : Introduction-Importance of Research, Types of research , Research Process-Problem Identification- Formulation-Classification, Concept and Construction of Hypothesis – Steps in Testing Hypothesis.

Unit-II: Research Design-Meaning, purpose and Principles – Types of Research Design – Exploratory- Descriptive- Experimental, Data Collection-Sources of Data-Methods of Data Collection-Questionnaire Design and Pre Testing of Questionnaire.

Unit-III: Sampling & Sampling Designs-Determination of Sample Size-Census Survey Vs Sample Survey –Advantages of Sampling-Sampling Methods-Probability Sampling-Non Probability Sampling.

Unit-IV: Data Tabulation-Analysis and Interpretation: Tabulation of data and general rules of tabulation Graphic and Diagrammatic Representation of Data-ANOVA-One way and Two way classification.

Unit-V: Research Report Writing and Presentation: Concept, Purpose, Guidelines for Research Report Writing –Steps in Report Writing-Layout of Report-Types of Research Reports-Presentation of Research Report.

Reference Books:

1. Panneer Selvam- Research Methodology, 2nd Edition (2014) PHI
2. Bhattacharya D.K., “Research Methodology” New Delhi. 2nd Edition (2006) Excel Books
3. Cooper, “Business Research Methods”, , New Delhi. 11th Edition (2012) Tata McGraw Hill

The Guidelines to be followed by the question paper setters in BUSINESS ANALYTICS AND RESEARCH METHODS for the second semester-end exams

PAPER TITLE: BUSINESS ANALYTICS AND RESEARCH METHODS

PAPER-V Semester-II Maximum Marks: 70 Duration: 3 Hours

Weightage for the question paper

Syllabus	Section –A (short answer questions) (with internal choice)	Section- B (Long answer questions) (with internal choice)	Section –C (essay question) (with internal choice)
Unit -1	1 (a or b)	1 (a or b)	Any unit
Unit -2	1 (a or b)	1 (a or b)	
Unit -3	1 (a or b)	1 (a or b)	
Unit -4	1 (a or b)	1 (a or b)	
Unit -5	1 (a or b)	1 (a or b)	

- Each short answer question carries 4 marks in section-A.
- Each long answer question carries 8 marks in section-B.
- Each essay answer question carries 10 marks in section-C.

The Question Paper Setters are requested to cover all the topics in the syllabus stipulated as per the weightage given by us.

**MODEL QUESTION PAPER
M.COM. (REGULAR) DEGREE EXAMINATION**

Second Semester

BUSINESS RESEARCH METHODS

(2017-2018 Regulation Onwards)

Time: Three hours

Maximum Marks: 70

SECTION- A

Answer Any Five of the Following Questions

(5X4 = 20 Marks)

1. Write short notes on:

a) (i) Importance of Research

(OR)

(ii) Simple Random Sampling

b) (i) Research Problem

(OR)

(ii) Primary Vs Secondary data

c) (i) Procedure for Testing of Hypothesis

(OR)

(ii) Bar and Pie charts

d) (i) Layout of report

(OR)

(ii) Types of Tabulation

e) (i) ANOVA

(OR)

(ii) Research Design.

SECTION- B

Answer All Questions.

(5X8 = 40 Marks)

2. a) What is Research? Explain the research process in details.

(OR)

b) Explain different types of research.

3. a) What is Research Design ? Distinguish between diagnostic and Exploratory Research designs.

(OR)

b) Briefly explain various techniques of data collection in business research.

4. a) Explain Principal steps in a Sample Survey?

(OR)

b) Distinguish between Systematic and Stratified Sampling.

5. a) What are different parts of statistical table? Give an example to illustrate.

(OR)

b) Explain the procedure for analysis of variance (ANOVA) two-way classification.

6. a) Explain various types of research reports used in business research?

(OR)

b) Explain the significance of research report and narrate the various steps involved in writing such a report.

SECTION- C

Answer the following question.

(1 x 10=10 marks)

7. a) Set up an analysis of variance table for the following per acre production data for three varieties of wheat, each grown on 4 plots and state if the variety differences are significant.

Plot of Land	Per acre production data		
	Variety of Wheat		
	A	B	C
1	6	5	5
2	7	5	4
3	3	3	3
4	8	7	4

(OR)

b) Explain the criteria of Good Research and also explain problems encountered by researchers in India.

AG&SG SIDDHARTHA DEGREE COLLEGE OF ARTS & SCIENCE VUYYURU

(An Autonomous college under the jurisdiction of Krishna University)

Reaccredited at the level 'A' by the NAAC

E-COMMERCE

Subject Code :	CO206	I A Marks	30
No. of Lecture Hours / Week	05	End Exam Marks	70
Total Number of Lecture Hours	75	Total Marks	100
Practical Component	01 Hour/Week	Exam Hours	03

Course Outcomes: By the end of the course, students will be able:

- CO-1 To remember and understand the basic concepts of E-commerce, E-business Internet and World Wide Web.
- CO-2 To understand how different technologies are implemented in e-commerce.
- CO-3 To analyse the role of e-marketing and advertisements in e-commerce.
- CO-4 To analyse the impact of CRM and SCM on e-commerce.
- CO-5 To learn about different types of electronic payment system, protocols, security schemes and cash less economy.

Unit-I : History of E-commerce and Indian Business Context: origin of E-commerce – Traditional vs. E-Commerce - Internet and World Wide Web- Business Models for e-Commerce-B2C, B2B, C2C & C2B, Merits and Limitations- Advantages and Disadvantages of E-commerce - Introduction to E-business -E-commerce vs E-business

Unit-II: Technologies of the World Wide Web- Internet client-server application-Telnet, PTP, IRC, Chat, ICQ & MIME, Networks & Internet :communication switching -Network routers-URL-IPv6-TCP web site-Website goals & Objectives Strategies for website Development-ISP Broadband Technologies- Hypertext- JavaScript and XML

Unit-III: E-Marketing- Traditional Marketing, Online Marketing- Advantages of online Marketing - Advertisements in E-commerce- various means of advertising- advertisement strategies-Intelligent Agents.

Unit-IV: CRM-Traditional methods-Technology support-E-CRM-Customer Life Cycle- CRM Capabilities and Customer Life Cycle-Data Mining in CRM - e-Supply Chain- Old ways of Managing supply and information flow-new ways of managing supply chain- several ways to reduce inventory- Real time benefits of e-Supply Chain- objectives of SCM -E-supply chain Components and architecture-Major trends in E-SCM

Unit-V: E-Commerce Payment Systems-Electronic Payments with Protocols-Security schemes-Electronic Fund Transfer and Debit Cards-E-Cash, Properties of E-Cash-E-Cash in Action- Operational Risk and E-Cash-Legal issues- E- Cheque - Risk and E-Payments Systems- Cashless Economy

References

1. PT Joseph SJ E-Commerce, An Indian Perspective, 3rd Edition, Volume 2, (2010), Prentice Hall of India
2. Effraim Turban, Joe Lee, David Kind-H Michael Chung E-Commerce, A Management Perspective, 6th Edition (2009), Pearson Education Asia.
3. Pandey US & ShuklaEr. S., E-Commerce & M- Commerce Technology, Revised Edition (2018), S. Chand& Company New Delhi.
4. Gary P. Schneider, E-Commerce Strategy Technology & Implementation, 9th Edition (2012), Cengage Learning, New Delhi.
5. Trepper, E-Commerce Strategies, Prentice Hall of India (2006) revised Edition, New Delhi.
6. Jonathan Reynolds, E-Business A Management Perspective 2nd Edition (2009), Oxford University Press.

The Guidelines to be followed by the question paper setters in E-COMMERCE for the second semester-end exams

PAPER TITLE: E-COMMERCE

PAPER-VI Semester-II Maximum Marks: 70 Duration: 3 Hours

Weightage for the question paper

Syllabus	Section –A (short answer questions) (with internal choice)	Section- B (Long answer questions) (with internal choice)	Section –C (essay question) (with internal choice)
Unit -1	1 (a or b)	1 (a or b)	Any unit
Unit -2	1 (a or b)	1 (a or b)	
Unit -3	1 (a or b)	1 (a or b)	
Unit -4	1 (a or b)	1 (a or b)	
Unit -5	1 (a or b)	1 (a or b)	

- Each short answer question carries 4 marks in section-A.
- Each long answer question carries 8 marks in section-B.
- Each essay answer question carries 10 marks in section-C.

The Question Paper Setters are requested to cover all the topics in the syllabus stipulated as per the weightage given by us.

MODEL QUESTION PAPER
M.COM. (REGULAR) DEGREE EXAMINATION
Second Semester
E-COMMERCE
(2017-2018 Regulation Onwards)

Duration: 3 hours

Maximum Marks: 70

SECTION- A

Answer Any Five of the Following Questions

5×4=20 Marks

1. Write short notes on:

a) (i) B2C

(OR)

(ii) World Wide Web

b) (i) Software Agent

(OR)

(ii) XML

c) (i) Intelligent Agents

(OR)

(ii) Supply Chain Management

d) (i) Electronic Fund Transfer

(OR)

(ii) Online Marketing

e) (i) E-Cash

(OR)

(ii) Website Goals

SECTION – B

Answer All Questions

5×8=40Marks

2. (a) Explain Business models of E-commerce.

(Or)

(b) What are the advantages and Disadvantages of E-commerce? s

3. (a) Explain Internet Client-Server Applications.

(Or)

(b) Explain Website goals, Objectives and Strategies.

4. (a) What is e-marketing? Distinguish E-marketing and Traditional Marketing

(Or)

(b) What are the strategies and advantages of advertisements in e-commerce?

5. (a) Explain Old ways of managing supply and information flow-new way of Managing supply chain and Supply chain Architecture.

(Or)

(b) Explain CRM Technology, CRM toolkit and CRM customer life cycle.

6. (a) Explain various security schemes in Electronic Payment System.

(Or)

(b) Explain Different protocols used in Electronic Payment system.

SECTION - C

Answer the following question.

(1 x 10=10 marks)

7. (a) Explain the concept of ISP Broadband Technologies.

(Or)

(b) Explain the Role of E-commerce in India.

AG&SG SIDDHARTHA DEGREE COLLEGE OF ARTS & SCIENCE VUYYURU

(An Autonomous college under the jurisdiction of Krishna University)

Reaccredited at the level 'A' by the NAAC

HUMAN VALUES AND ETHICS (1L + 1T + 1P)

Subject Code :	GE02	I A Marks	50
No. of Lecture Hours / Week	03	End Exam Marks	-
Total Number of Lecture Hours	45	Total Marks	50
Practical Component	01 Hour/Week	Exam Hours	03

Course Outcomes: By the end of the course, students will be able:

- CO 1 To provide the basic understanding about importance of Value Education, Self-Exploration, and Human aspirations.
- CO 2 To understand the importance of Process for Value Education
- CO 3 To gain knowledge on Understanding Harmony in the Human Being
- CO 4 To understand the concept of Harmony in Myself
- CO 5 Understanding Harmony in the Family and Society – harmony in Human - Human Relationship

Unit – I: Introduction –Need, Basic Guidelines and Content

1. Understanding the need , basic guidelines, content and process for value Education
2. Self-Exploration – What is it? – its content and process: ‘Natural Acceptance’ and Experiential Validation – as the mechanism for self-explanation
3. Continuous Happiness and Prosperity – A look at basic Human Aspirations

Unit – II: Process for Value Education

1. Right Understanding, Relationship and Physical Facilities – basic requirements for fulfillment of aspirations of every human being with their correct priority
2. Understanding Happiness and prosperity correctly – A critical appraisal of the current Scenario 17
3. Method to fulfill the above human aspirations; understanding and living in harmony at various levels

Unit – III: Understanding Harmony in the Human Being

1. Understanding human being as a co-existence of the sentient ‘I’ and the material ‘Body’
2. Understanding the needs of Self (‘I’) and ‘Body’
3. Understanding the Body as an instrument of ‘I’ (I being the doer, seer and enjoyer)

Unit –IV: Harmony in Myself

1. Understanding the characteristics and activities of ‘I’ and harmony in ‘I’
2. Understanding the harmony of I with the Body - correct appraisal of Physical needs, meaning of Prosperity in detail
3. Programs to ensure Sanyam and Swasthya – practice exercises and Case Studies will be taken up in Practice Sessions.

Unit – V: Understanding Harmony in the Family and Society – harmony in Human - Human Relationship

1. Understanding harmony in the family – the basic unit of human interaction
2. Understanding values in human relationship; meaning of Nyaya and Program for its fulfillment to ensure Ubhay-tripti
3. Trust (Vishwas) and Respect (Samman) as the foundational values of relationship.

Text Books

R R Gaur, R, Sangal, G.P Bagaria, 2009, A Foundation Course in value Education(English)
Pradeep Kumar Ramancharla, 2013, A foundation course in value education (Telugu)
R R Gaur, R Sangal G P Bagaria, 2009, Teacher’s Manual (English)
Pradeep Kumar Ramancharla, 2013, Teacher’s Manual (Telugu)

Reference Books

1. Ivan Illich, 1974, Energy & Equity, The Trinity Press, Worcester, and Harper Collins, USA
2. E.F. Schumacher, 1973, small is Beautiful; a study of economics as if people mattered, Blond & Briggs, Britain
3. A Nagraj, 1998, Jeevanvidya to Na Prayanam, Hyderabad
4. R. Pradeep Kumar, 2013, JeevanVidya to Na Prayanam, Hyderabad
5. Susan George, 1976, How the other half Dies, Penguin Press, Reprinted 1986, 1991
6. P.L Dhar, R.R Gaur, 1990, Science and Humanism, common wealth publishers
18
7. A.N. Tripathy, 2003, Human values, New Age International Publishers
8. Subhas Palekar, 2000, How to practice natural Farming, Pracheen (Vaidik)
Krishitantrashodh, Amravati
9. Donella H. Meadows, Dennis L. Meadows, Jorgen Randers, William W. Behrens III, 1972, Limits to Growth – club of Rome’s report, universe Books
10. E.G. Seebauer & Robert, L BERRY, 2000, Foundations of Ethics for Scientists & Engineers, Oxford University Press
11. M. Govindrajran, S Natrajan & V.S. Senthikumar, Engineering Ethics (including human Values), Eastern Economy Edition, Prentice hall of India Ltd
12. B P Banerjee, 2005, Foundations of Ethics and Management, Excel books
13. B.L. Bajpai, 2004, Indian Ethos and Modern Management, New Royal book Co;
Lucknow, Reprinted 2008

Relevant CDs, Movies, Documentaries & Other Literature

1. Value Education Website, <http://www.uptu.ac.in>
2. Story of Stuff, <http://www.storyofstuff.com>
3. Al Gore, An Inconvenient Truth, paramount Classics, USA
4. Charlie Chaplin, Modern Times, United Artists, USA



A. G & S.G. SIDDHARTHA DEGREE COLLEGE OF ARTS & SCIENCE
(Autonomous), Vuyyuru-521165.
NAAC reaccredited at 'A' level
Autonomous -ISO 9001 – 2015 Certified

TITLE OF THE PAPER: PROJECT PLANNING AND CONTROL

Semester: IV

CO402 PROJECT PLANNING AND CONTROL (4L + 1T + 1P)

Course Code	CO402	Course Delivery Method	Class Room / Blended Mode - Both
Credits	4	CIA Marks	30
No. of Lecture Hours / Week	5	Semester End Exam Marks	70
Total Number of Lecture Hours	75	Total Marks	100
Practical Component	01 Hour/Week	Exam Hours	03
Year of Introduction:	Year of Offering: 2021 - 22	Year of Revision: ----	Percentage of Revision: 0%
CLASS:	II M.Com		

Course Outcomes: By the end of the course, students will be able:

- CO 1 To identify the new projects and investment opportunities.
- CO 2 To understand the market and demand analysis for new project.
- CO 3 To develop Investment criteria and appraisal process.
- CO 4 To enable the students to understand social cost benefit analysis.
- CO 5 To imparts skills in the use of network techniques for project implementation.

UNIT-I

Generation and Screening of Project Ideas – Generation of ideas – Monitoring Environment – Corporate Appraisal – Profit Potential of Industries – Porter Model – Scouting for Project Ideas – Preliminary screening – Project Rating Index – Sources of Positive Net Present Value.

UNIT-II

Market and Demand Analysis: Information required for market and demand analysis; sources of information – primary and secondary; demand forecasting – Technical Analysis – Materials and inputs; Production technology – Product mix – Plant location and layout – Selection of plant and equipment.

UNIT-III

Financial Estimates and Investment Criteria – Cost of Project – Means of Finance – Estimates of sales and production – Cost of Production – Investment Criteria: Net Present Value – Benefit Cost Ratio – Internal Rate of Return – Pay Back Period – and Accounting Rate of Return. Investment Appraisal: Indian Practice.

UNIT-IV

Social Cost Benefit Analysis – Rationale for social cost benefit analysis – Methodology of SCBA – L&M approach and UNIDO approach – Measurement of the impact on distribution – SCBA in India

UNIT-V

Network techniques for Project Implementation – Monitoring and Control – PERT and CPM techniques – Critical path – event slacks and activity floats – Measures of variability and probability of completion by a specified date – Project implementation practices in India.

References:

1. Prasanna Chandra, Projects – Planning – Analysis – Financing – Implementation – and Review. 9th(2019) Edition Tata McGraw Hill
2. Chandra Prasanna, Project Preparation – Appraisal and Implementation, 3rd Edition (1987) Tata McGraw Hill – Delhi
3. Timothy – D.R. and W.R. Wesell, Project Appraisal and Review– 76 (11) 1992 Macmillan – India.
4. Chaudhary S, Project Management, 5th Edition (1995), Tata McGraw Hill New Delhi.
5. Little I.M.D. and Mirrless JA, Project Appraisal and Planning for Developing Countries (1974) Heinemann Education Books London.

The Guidelines to be followed by the question paper setters in **CO402- PROJECT PLANNING AND CONTROL** for the fourth semester-end exams

PAPER TITLE: CO402- PROJECT PLANNING AND CONTROL

PAPER- II Semester-IV Maximum Marks: 70 Duration: 3 Hours
Weightage for the question paper

Syllabus	Section –A (short answer questions) (with internal choice)	Section- B (Long answer questions) (with internal choice)	Section –C (essay question) (with internal choice)
Unit -1	1 (a or b)	1 (a or b)	Any unit
Unit -2	1 (a or b)	1 (a or b)	
Unit -3	1 (a or b)	1 (a or b)	
Unit -4	1 (a or b)	1 (a or b)	
Unit -5	1 (a or b)	1 (a or b)	

- CO 1 Each short answer question carries 4 marks in section-A.
- CO 2 Each long answer question carries 8 marks in section-B.
- CO 3 Each essay answer question carries 10 marks in section-C.

The Question Paper Setters are requested to cover all the topics in the syllabus stipulated as per the weightage given by us.

**A. G & S.G. SIDDHARTHA DEGREE COLLEGE OF ARTS & SCIENCE
(Autonomous), Vuyyuru-521165.**

**MODEL QUESTION PAPER
M.COM. (REGULAR) DEGREE EXAMINATION
Fourth Semester
CO402 –PROJECT PLANNING AND CONTROL
(2021-2022 Regulation Onwards)**

Duration: 3 hours

Maximum Marks: 70

SECTION- A

Answer All Questions

5×4=20 Marks

1. Write short notes on

- i. a) Environmental scanning. OR
b) Project Rating Index.
- ii. a) Product mix. OR
b) Primary data..
- iii. a) Payback period.. OR
b) Cost of project
- iv. a) Shadow Prices. .OR
b) Social cost benefit
- v. a) Total and free floats. .OR
b) Critical path

SECTION – B

Answer All Questions

5×8=40 Marks

2. a) Explain the process of generating and screening of project ideas.
OR
b) Explain porter model for profit potential of industries
3. a) What is plant location? Explain the factors influencing plant location.
OR
b) Explain different sources of primary and secondary information.
4. a) What are the components of cost of project? Discuss them in brief.
OR
b) Discuss briefly the various means of financing a project.

5. a) What is social cost benefit analysis and explain UNIDO approach.

OR

b) Explain social cost benefit analysis in India.

6. a) What is network analysis? Explain the rules for construction of network diagrams.

OR

b) Discuss the project implementation practices in India.

SECTION C - (1 x 10 =10 marks)

Case study (Compulsory)

7. Explain environmental scanning and opportunity analysis.

OR

What is demand forecasting? Explain qualitative and time series projection methods. .

A. G & S.G. SIDDHARTHA DEGREE COLLEGE OF ARTS & SCIENCE
(Autonomous), Vuyyuru-521165.
NAAC recredited at 'A' level
Autonomous -ISO 9001 – 2015 Certified

TITLE OF THE PAPER: INTERNATIONAL BUSINESS

Semester: IV

CO403 INTERNATIONAL BUSINESS (4L + 1T + 1P)

Course Code	CO403	Course Delivery Method	Class Room / Blended Mode - Both
Credits	4	CIA Marks	30
No. of Lecture Hours / Week	5	Semester End Exam Marks	70
Total Number of Lecture Hours	75	Total Marks	100
Practical Component	01 Hour/Week	Exam Hours	03
Year of Introduction:	Year of Offering: 2021 - 22	Year of Revision: ----	Percentage of Revision: 0%
CLASS:	II M.Com		

Course Outcomes:By the end of the course, students will be able:

- CO 1 To familiarize the students with international trade theories
- CO 2 To enable the students to understand the international trade regulatory framework.
- CO 3 To equip the students with the basic concept of international financial framework
- CO 4 To impart knowledge on international economic institutions
- CO 5 To understand how to organise international business.

UNIT-I: International Business: Concept of international business – Stages of internationalization of business – Impact of globalization - International economic, political, legal, competitive, social demographic and cultural frame work - International trade theories.

UNIT -II: International trade regulatory frame work -Trade barriers – Export promotion and import substitution - Role of World Trade Organization (WTO) - Integrity pact.

UNIT -III: International financial frame work - Balance of payments – Foreign exchange market mechanism, export financing, and incentives – Role of MNCs in International Business.

UNIT -IV: International Economic Institutions Agencies and Agreements: Regional Trading agreements – The European Union and NAFTA – Debate on Trade Policy i.e. Free Trade Vs Protectionism.

UNIT -V: Organizing for international business – Designing global organization structure – Developing global competitiveness - EOUs, EPZs - Role of State and Centre to promote international trade

References

1. Francis Cherunilam, International Business, PHI.
2. Bhattacharya, International Business, Excel Books, New Delhi.
3. John D.Daniels & Lee H. Radebaugh., International Business, Pearson Education.
4. P. Subba Rao, International Business, Himalaya Publishing House.
5. R. Chandran, International Business, Jaico Publishing House
6. Vyuptakesh Sharam, International Business, Pearson education, 2006.
7. K.Aswathappa, International Business, Tata McGraw-Hill, 2006.
8. Bhalla Madhava. V.K., International Business, New Delhi.
9. Shukla, International Business, Excel Books, New Delhi.
10. Sundarmos Black; International Business Environment, Prentice Hall of India.
11. Ramesh Mohan Joshi, International Business, Oxford University Press
12. Pradip Kumar Sinha, Sanchari Sinha, International Business Management, Excel Book

The Guidelines to be followed by the question paper setters in **CO403-INTERNATIONAL BUSINESS** for the fourth semester-end exams

PAPER TITLE:CO403- INTERNATIONAL BUSINESS

PAPER- III Semester-IV Maximum Marks: 70 Duration: 3 Hours

Weight age for the question paper

Syllabus	Section –A (Short answer questions) (with internal choice)	Section- B (Long answer questions) (with internal choice)	Section –C (Essay question) (with internal choice)
Unit -1	1 (a or b)	1 (a or b)	Any unit
Unit -2	1 (a or b)	1 (a or b)	
Unit -3	1 (a or b)	1 (a or b)	
Unit -4	1 (a or b)	1 (a or b)	
Unit -5	1 (a or b)	1 (a or b)	

- CO 1 Each short answer question carries 4 marks in section-A.
- CO 2 Each long answer question carries 8 marks in section-B.
- CO 3 Each essay answer question carries 10 marks in section-C.

The Question Paper Setters are requested to cover all the topics in the syllabus stipulated as per the weightage given by us.

**A. G & S.G. SIDDHARTHA DEGREE COLLEGE OF ARTS & SCIENCE
(Autonomous), Vuyyuru-521165.**

**MODEL QUESTION PAPER
M.COM. (REGULAR) DEGREE EXAMINATION
Fourth Semester
CO403 – INTERNATIONAL BUSINESS
(2021-2022 Regulation Onwards)**

Duration: 3 hours

Maximum Marks: 70

SECTION- A

Answer All Questions

5×4=20 Marks

1. Write short notes on

- i. a) International Business. OR
b) Globalisation.
- ii. a) WTO. OR
b) Trade barriers.
- iii. a) Balance of Payments. OR
b) MNCs
- iv. a) Regional Trading Agreements. OR
b) Trade Policy.
- v. a) EOUs. OR
b) EPZs

SECTION – B

Answer All Questions

5×8=40Marks

2. a) Explain the concept of international business.
OR
b) Explain the stages of internationalisation of business.
3. a) Explain the concept of export promotion and import substitution.
OR
b) Explain the role of World Trade Organisation in international business.
4. a) Explain the Foreign exchange market mechanism.
OR
b) Discuss the role of MNCs in international business.
5. a) Explain the concept of free trade Vs protectionism.
OR
b) Explain the European Union NAFTA.
6. a) What is the role of state and centre for promote international trade?
OR
b) Discuss the designing of global organisation structure.

SECTION C - (1 x 10 =10 marks)

Case study (Compulsory)

7. a) Explain the international social, political and economic framework.
OR
b) Explain the barriers in international trade.

A. G & S.G. SIDDHARTHA DEGREE COLLEGE OF ARTS & SCIENCE
(Autonomous), Vuyyuru-521165.
NAAC recredited at 'A' level
Autonomous -ISO 9001 – 2015 Certified

TITLE OF THE PAPER: MOOCS – Organisational Behaviour

Semester: IV

CO401: MOOCS - Organizational Behaviour

Course Code	CO401	Course Delivery Method	Class Room / Blended Mode - Both
Credits	4	CIA Marks	30
No. of Lecture Hours / Week	5	Semester End Exam Marks	70
Total Number of Lecture Hours	75	Total Marks	100
Practical Component	01 Hour/Week	Exam Hours	03
Year of Introduction:	Year of Offering: 2021 - 22	Year of Revision: ----	Percentage of Revision: 0%
CLASS:	II M.Com		

Course Objectives: The course is to make student aware of the concept to provide opportunity for learner to interact directly with world class teachers who are offering courses on MOOCs platform.

Course Outcomes:

CO-1 To provide students with audio and video content relating with the contemporary subjects.

CO-2 To improve the self-learning capabilities of the students

CO-3 To help the learners to learn continuously while doing the course and after the course completion.

CO-4 To provide opportunity for learner to interact directly with world class teachers who are offering courses on MOOCs platform.

CO-5 To expose the learners with peer learning facility

Unit-I: Organizational Behaviour: Meaning, concept, importance and fields of study, roles & skills of managers, Organizational Behaviour challenges, field of OB : individual, groups & systems as building blocks, OB models.

Unit-II: Evolution of Organizational Behaviour, Research of OB, International OB, Perception, Personality, Learning: concept & theories, facilit

Unit-III: Attitude : meaning, concept, formation and change, Motivation : process theories, job satisfaction, emotions and emotional intelligence, formation of groups, types of groups.

Unit- IV: Team dynamics, group decision making, interpersonal relations, Communication : nature, types and barriers, Leadership : nature, importance, styles, theories of leadership, power & politics, conflicts, foundations of organization structure.

Unit- V: Organizational design, diversity and it's management, stress among employees, work life balance, Organizational change & development, Organizational culture, employee empowerment, learning organization, ethical behavior in organization

Reference :

1. Stephen P. Robbins, Organizational Behaviour Concepts, Prentice hall, India.
2. L. M. Prasad, Management Process and Organizational, Sultan Chand & Sons.
3. Aswathappa. K, Organizational Behaviour , Himalaya Publishing House.
4. Nair, S. R, Organizational Behaviour (text & cases) Himalaya Publishing House.

The Guidelines to be followed by the question paper setters in **CO401- MOOCS: ORGANIZATIONAL BEHAVIOUR** for the fourth semester-end exams

PAPER TITLE: CO401 - MOOCS : ORGANIZATIONAL BEHAVIOUR

PAPER- I Semester-IV Maximum Marks: 70 Duration: 3 Hours

Weightage for the question paper

Syllabus	Section –A (Short answer questions) (with internal choice)	Section- B (Long answer questions) (with internal choice)	Section –C (Essay question) (with internal choice)
Unit -1	1 (a or b)	1 (a or b)	Any unit
Unit -2	1 (a or b)	1 (a or b)	
Unit -3	1 (a or b)	1 (a or b)	
Unit -4	1 (a or b)	1 (a or b)	
Unit -5	1 (a or b)	1 (a or b)	

- Each short answer question carries 4 marks in section-A.
- Each long answer question carries 8 marks in section-B.
- Each essay answer question carries 10 marks in section-C.

The Question Paper Setters are requested to cover all the topics in the syllabus stipulated as per the weightage given by us.

**A. G & S.G. SIDDHARTHA DEGREE COLLEGE OF ARTS & SCIENCE
(Autonomous), Vuyyuru-521165.**

**MODEL QUESTION PAPER
M.COM. (REGULAR) DEGREE EXAMINATION
Fourth Semester
CO401 –MOOCS- Organisational Behaviour
(2021-2022 Regulation Onwards)**

Section - A

Answer any **FIVE** of the following:

(5 x 4 = 20M)

1. a i. Organizational Behaviour or
ii. Skills of managers
- b i. Perception or
ii. Learning
- c i. Job satisfaction or
ii. Emotional intelligence
- d i. Leadership or
ii. Communication
- e i. Organizational design or
ii. Employee empowerment

Section – B

Answer any **FIVE** of the following:

(5 x 8 = 40M)

2. a. Discuss the concept and importance of Organizational Behaviour.
or
b. Discuss the various models of Organizational Behaviour.
3. a. Explain various stages in personality development.
or
b. Discuss various steps in perceptual process.
4. a. Elucidate the concept of motivation and motives. Why motivation is needed?
or
b. What do you understand by group? Explain the various stages of group formation.
5. a. Define leadership and explain various styles of leadership.
or
b. State the process and importance of communication with examples.
6. a. Discuss the importance of organizational culture.
or
b. Identify the factors causing stress and suggest suitable stress management techniques.

Section – C (1x10 Marks = 10 Marks)

7. a. Discuss the importance of group dynamics in modern organizations.
or
b. Explicate the concept of behaviour modification. Highlight various behaviour modification techniques.

A. G & S.G. SIDDHARTHA DEGREE COLLEGE OF ARTS & SCIENCE
(Autonomous), Vuyyuru-521165.
NAAC reaccredited at 'A' level
Autonomous -ISO 9001 – 2015 Certified

TITLE OF THE PAPER: INTERNATIONAL BANKING

Semester: IV

CO404 INTERNATIONAL BANKING (4L + 1T + 1P)

Course Code	CO404	Course Delivery Method	Class Room / Blended Mode - Both
Credits	4	CIA Marks	30
No. of Lecture Hours / Week	5	Semester End Exam Marks	70
Total Number of Lecture Hours	75	Total Marks	100
Practical Component	01 Hour/Week	Exam Hours	03
Year of Introduction:	Year of Offering: 2021 - 22	Year of Revision: ----	Percentage of Revision: 0%
CLASS:	II M.Com		

Course Outcomes:By the end of the course, students will be able:

- CO 1 Understand the global trends and developments in international banking
- CO 2 Get familiar with the international financial centres
- CO 3 Able to identify banking system in UK, USA etc.
- CO 4 Able to understand the functioning of international financial institutions
- CO 5 Able to develop knowledge about regulatory framework in india.

UNIT – I :

Introduction- Global trends and developments in International Banking Wholesale banking- Retail banking- private banking- inter-bank business

UNIT – II :

International Financial Centres - Offshore Banking units - SEZs- Asset Liability Management- Profitability of International Banking Operations

UNIT – III :

Investment Banking: Wholesale Banking - Unit Banking – Federal Banking System – Investment Banking - Correspondent Banking – Banking System in UK, USA, Germany and Japan - Global trends and developments in International Banking.

UNIT – IV :

International Financial Institutions; IMF , IBRD, BIS, IFC, ADB, WTO, Treasury and Risk Mitigation

UNIT – V :

Regulatory Framework in India and FEMA, Letter of Credit mechanism and UCPDC URC / URR Buyers' / Sellers' credit- Bilateral trade- counter trade- high seas sales.

References

1. International Banking Operations, Libf, Macmillan Publishers India Limited, 2007.
2. Domestic and International Banking, M.K. Lewis & K.T. Davis, The MIT Press, 1987.
3. Hand Book of International Banking, A. W. Mullineux & Victor Murinde, Edward Elgar Publishing, 2003.
4. International Banking, Nicholas L. Deak & JoAnne Celusak, New York Institute of Finance, 1984.
5. International Banking and Finance, Francis A. Lees, Macmillan Press, 1980.
6. Multinational and International Banking, Geoffrey Jones, E.Elgar, 1984.

The Guidelines to be followed by the question paper setters in **CO404-INTERNATIONAL BANKING** for the fourth semester-end exams

PAPER TITLE: CO404- INTERNATIONAL BANKING

PAPER- IV Semester-IV Maximum Marks: 70 Duration: 3 Hours

Weightage for the question paper

Syllabus	Section –A (short answer questions) (with internal choice)	Section- B (Long answer questions) (with internal choice)	Section –C (essay question) (with internal choice)
Unit -1	1 (a or b)	1 (a or b)	Any unit
Unit -2	1 (a or b)	1 (a or b)	
Unit -3	1 (a or b)	1 (a or b)	
Unit -4	1 (a or b)	1 (a or b)	
Unit -5	1 (a or b)	1 (a or b)	

CO 4 Each short answer question carries 4 marks in Section-A.

CO 5 Each long answer question carries 8 marks in Section-B.

CO 6 Each essay answer question carries 10 marks in Section-C.

The Question Paper Setters are requested to cover all the topics in the syllabus stipulated as per the weightage given by us.

**A. G & S.G. SIDDHARTHA DEGREE COLLEGE OF ARTS & SCIENCE
(Autonomous), Vuyyuru-521165.**

**MODEL QUESTION PAPER
M.COM. (REGULAR) DEGREE EXAMINATION
Fourth Semester
CO404 – INTERNATIONAL BANKING
(2021-2022 Regulation Onwards)**

Section - A

Answer any FIVE of the following:

(5 x 4 = 20M)

1. a i. Private Banks. (or)
ii. Nature of international banking.
- b i. Special Economic zones. (or)
ii. Asset Management.
- c i. Unit banking. (or)
ii. Banking system in UK.
- d i. BIS. (or)
ii. ADB.
- e i. URC Buyers. (or)
ii. Unilateral trade.

Section – B

Answer any FIVE of the following:

(5 x 8 = 40)

2. a. Explain the nature and objectives of retail banking.
(or)
b. Write about recent developments in international banking?
3. a. What are the various privileges available to SEZs? Explain.
(or)
b. Explain about profitability of international banking operations.
4. a. Write about banking system in Germany?
(or)
b. Give an overview on federal banking systems.
5. a. State the functions of world bank.
(or)
b. List out the objectives of WTO.
6. a. Discuss about foreign exchange mechanism in India.
(or)
b. What are the features of bilateral trade agreements?

Section – C (1x10 Marks = 10 Marks)

7. a. Explain about risk mitigation in international financial institutions.
(or)
b. Give an overview on inter-bank business.

A. G & S.G. SIDDHARTHA DEGREE COLLEGE OF ARTS & SCIENCE
(Autonomous), Vuyyuru-521165.
NAAC recredited at 'A' level
Autonomous -ISO 9001 – 2015 Certified

TITLE OF THE PAPER: FINANCIAL SERVICES

Semester: IV

CO405: FINANCIAL SERVICES
(4L + 1T + 1P)

Course Code	CO405	Course Delivery Method	Class Room / Blended Mode - Both
Credits	4	CIA Marks	30
No. of Lecture Hours / Week	5	Semester End Exam Marks	70
Total Number of Lecture Hours	75	Total Marks	100
Practical Component	01 Hour/Week	Exam Hours	03
Year of Introduction:	Year of Offering: 2021 - 22	Year of Revision: ----	Percentage of Revision: 0%
CLASS:	II M.Com		

Course Outcomes: By the end of the course, students will be able:

- CO 1 To create awareness among the students about the significance of investment particularly strategic investment and finance decision-making.
- CO 2 The objective of the course is to provide students with the knowledge of merchant banking services along with guidelines of SEBI.
- CO 3 To understand Mutual Funds and the origin of venture capital.
- CO 4 To understand the types of lease agreements and factoring services in India.
- CO 5 To examine the emerging trends in financial services.

UNIT – I

Financial Services – Range of services – Characteristics – Institutions offering different services – Characteristics of financial services market – Problems and challenges in financial services marketing.

UNIT – II

Merchant Banking – Nature and scope of merchant banking services – Management of public issues and support services – Depository services – Marketing of services – SEBI guidelines.

UNIT – III

Mutual Funds – Meaning, Origin, Types/Classification of Funds, Importance, Mutual Funds Industry in India – **Venture Capital**: Meaning, Origin, Importance, Methods, India Scenario.

UNIT – IV

Leasing – Concept, Types, Lease Agreements – Potentiality of Leasing as a means of financing – Advantages, and Disadvantages – Lease Financing in India – **Factoring** – Meaning, Modus operandi, types, and functions – Factoring services in India.

UNIT V

Trends in Financial Services – Financial technology firms (Fintech Firms), Data-Driven Product Development, Digital Transformation, AI (artificial intelligence)& Block Chain, Big Data, Cyber Security, Mobile Banking, OMNI-Channel, Investor Education.

Reference Books:

1. David and Zenoff, **Marketing of Financial services**, Ballinger publishing.
2. Avadhani, V.A., **Marketing of Financial Services**, Himalaya Publishing House, Mumbai.
3. J.C. Verma, **Merchant Banking**, Tata McGraw- Hill.
4. Bhalla. V.K. **Management of Financial Services**, Anmol Publications, New Delhi.
5. ChinmaoySahu, **Management of Financial Services**, Excel Books, New Delhi.

The Guidelines to be followed by the question paper setters in **CO405- FINANCIAL SERVICES** for the fourth semester-end exams

PAPER TITLE:CO405- FINANCIAL SERVICES

PAPER- V Semester-IV Maximum Marks: 70 Duration: 3 Hours

Weight age for the question paper

Syllabus	Section –A (Short answer questions) (with internal choice)	Section- B (Long answer questions) (with internal choice)	Section –C (Essay question) (with internal choice)
Unit -1	1 (a or b)	1 (a or b)	Any unit
Unit -2	1 (a or b)	1 (a or b)	
Unit -3	1 (a or b)	1 (a or b)	
Unit -4	1 (a or b)	1 (a or b)	
Unit -5	1 (a or b)	1 (a or b)	

- CO 1 Each short answer question carries 4 marks in section-A.
- CO 2 Each long answer question carries 8 marks in section-B.
- CO 3 Each essay answer question carries 10 marks in section-C.

The Question Paper Setters are requested to cover all the topics in the syllabus stipulated as per the weightage given by us.

**A. G & S.G. SIDDHARTHA DEGREE COLLEGE OF ARTS & SCIENCE
(Autonomous), Vuyyuru-521165.**

**MODEL QUESTION PAPER
M.COM. (REGULAR) DEGREE EXAMINATION
Fourth Semester
CO405 – FINANCIAL SERVICES
(2021-2022 Regulation Onwards)**

Duration: 3 hours

Maximum Marks: 70

SECTION- A

Answer All Questions

5×4=20 Marks

1. Write Short Notes on:

- i. a) characteristics of financial services market OR
b) challenges of a financial services market
- ii. a) Merchant banking OR
b) Depository services
- iii. a) Classification of funds OR
b) Venture Capital
- iv. a) Leasing OR
b) Factoring
- v. a) Digital Transformation OR
b) Investor Education.

SECTION – B

Answer All Questions

5×8=40 Marks

2. a) Explain different services offered by financial institutions.
OR
b) Explain the problems in financial services marketing
3. a) Explain the nature and scope of merchant banking services.
OR
b) Explain marketing of services – SEBI guidelines.
4. a) Explain the importance and mutual funds industry in india.
OR
b) Discuss the methods of venture capital.
5. a) Explain the lease agreements.
OR
b) Discuss factoring services in India.
6. a) Discuss the Data-Driven Product Development.
OR
b) Explain the advantages of Artificial Intelligence.

SECTION C - (1 x 10=10 marks)

Answer the following question.

7. a) Explain the management of public issues and support services in merchant banking.
OR
b) Discuss the types and functions of factoring.

A. G & S.G. SIDDHARTHA DEGREE COLLEGE OF ARTS & SCIENCE
(Autonomous), Vuyyuru-521165.
NAAC recredited at 'A' level
Autonomous -ISO 9001 – 2015 Certified

TITLE OF THE PAPER: BANKING AND TECHNOLOGY

Semester: IV

CO406: BANKING AND TECHNOLOGY (4L + 1T + 1P)

Course Code	CO406	Course Delivery Method	Class Room / Blended Mode - Both
Credits	4	CIA Marks	30
No. of Lecture Hours / Week	5	Semester End Exam Marks	70
Total Number of Lecture Hours	75	Total Marks	100
Practical Component	01 Hour/Week	Exam Hours	03
Year of Introduction:	Year of Offering: 2021 - 22	Year of Revision: ----	Percentage of Revision: 0%
CLASS:	II M.Com		

Course Outcomes: By the end of the course, students will be able:

- CO-1 To explain the role of information technology in Indian Banking Industry.
- CO-2 To explain the role of electronic banking and electronic fund management.
- CO-3 To explain how integrated communication networks works in banks and the role of CRM.
- CO-4 To explain how to manage disaster management and computer security. The role of computer audit and security control aspects.
- CO-5 To explain the importance of data warehousing and data mining techniques and its advantages.

UNIT – I

IT in Banking – Information Technology and its implications – Information Technology – Indian Banking Scenario – Initiatives and Trends.

UNIT – II

Applications in Banking – Computer based information System for Banking and Electronic Banking, Electronic Fund Management.

UNIT – III

Enabling Technologies of Modern Banking – Electronic Commerce and Banking – Customer Relationship Management – Integrated Communication Networks for Banks

UNIT – IV

Security and Control Systems – Computer Security and Disaster Management System – Audit and Computer Crime – Security and Control Aspects of Emerging Banking Technologies

UNIT – V:

Planning and Implementation of Information System – Data Warehousing and Data Mining – Designing and Implementing Computerization in Banking Sector

References:

1. Hawtrey. The Art of Central Banking. (1970) New York: Augustus M Kelley Publishers.
2. Desai, Vasant, Indian Banking, Nature and Problems 1st Edition (1980) Mumbai, Himalaya Publishing House.
3. Murdick, R.G., Ross, J.E., Clagget J.R, Information Systems for Modern Management. 3rd Edition (1988) PHI

The Guidelines to be followed by the question paper setters in **CO406- BANKING AND TECHNOLOGY** for the fourth semester-end exams

PAPER TITLE:CO406- BANKING AND TECHNOLOGY

PAPER- VI Semester-IV Maximum Marks: 70 Duration: 3 Hours

Weightage for the question paper

Syllabus	Section –A (short answer questions) (with internal choice)	Section- B (Long answer questions) (with internal choice)	Section –C (essay question) (with internal choice)
Unit -1	1 (a or b)	1 (a or b)	Any unit
Unit -2	1 (a or b)	1 (a or b)	
Unit -3	1 (a or b)	1 (a or b)	
Unit -4	1 (a or b)	1 (a or b)	
Unit -5	1 (a or b)	1 (a or b)	

- CO 1 Each short answer question carries 4 marks in section-A.
- CO 2 Each long answer question carries 8 marks in section-B.
- CO 3 Each essay answer question carries 10 marks in section-C.

The Question Paper Setters are requested to cover all the topics in the syllabus stipulated as per the weightage given by us.

**A. G & S.G. SIDDHARTHA DEGREE COLLEGE OF ARTS & SCIENCE
(Autonomous), Vuyyuru-521165.**

**MODEL QUESTION PAPER
M.COM. (REGULAR) DEGREE EXAMINATION
Fourth Semester
CO406 – BANKING AND TECHNOLOGY
(2021-2022 Regulation Onwards)**

Duration: 3 hours

Maximum Marks: 70

SECTION- A

Answer All Questions

5×4=20 Marks

1. **Write Short Notes on:**

- i. a) Information technology. OR
b) Banking trends.
- ii. a) Electronic Banking. OR
b) Computer based information system
- iii. a) Relationship Management. OR
b) Integrated communication network
- iv. a) Computer Security. OR
b) Computer Audit.
- v. a) Data Mining. OR
b) Data Warehousing

SECTION – B

Answer All Questions

5×8=40 Marks

2. a) Explain the role technology in Indian banking.
OR
b) Discuss the initiatives and new trends in Indian banking.
3. a) Discuss the role of computer based information system.
OR
b) Explain electronic fund management.
4. a) Explain Customer Relationship Management.
OR
b) Discuss integrated communication networks in banks.
5. a) Explain disaster management techniques.
OR
b) Discuss security control aspects in banking industry.
6. a) Discuss Data ware housing techniques.
OR
b) Explain the advantages of data mining.

SECTION C - (1 x 10=10 marks)

Answer the following question.

7. a) Explain how technology is playing a vital role in customer service.
OR
b) Discuss the future of Indian banking industry with latest technological developments.

A. G & S.G. SIDDHARTHA DEGREE COLLEGE OF ARTS & SCIENCE
(Autonomous), Vuyyuru-521165.
NAAC recredited at 'A' level
Autonomous -ISO 9001 – 2015 Certified

TITLE OF THE PAPER: INSURANCE PRODUCTS AND MANAGEMENT

Semester: IV

CO407: INSURANCE PRODUCTS AND MANAGEMENT (4L + 1T + 1P)

Course Code	CO407	Course Delivery Method	Class Room / Blended Mode - Both
Credits	4	CIA Marks	30
No. of Lecture Hours / Week	5	Semester End Exam Marks	70
Total Number of Lecture Hours	75	Total Marks	100
Practical Component	01 Hour/Week	Exam Hours	03
Year of Introduction:	Year of Offering: 2021 - 22	Year of Revision: ----	Percentage of Revision: 0%
CLASS:	II M.Com		

Course Outcomes:

By the end of the course, students will be able:

- CO 1 To develop and understand what life insurance and variation of whole life insurance
- CO 2 To familiarize students with life insurance contractual provisions
- CO 3 To discuss the matter related to health insurance coverage
- CO 4 To make the students understand employee benefits and retirement plans
- CO 5 To make them understand the concept of reinsurance.

UNIT – I :

Life Insurance Concept – Basic Principles of Life Insurance Utmost Good Faith – Insurance Interest – Types of Insurance – Variations of Whole Life Insurance – Other types of Life Insurance.

UNIT – II :

Life insurance Contractual Provisions – Dividend Options – Non Forfeiture Options – Settlement Options – Additional Life Insurance Benefits – Insurance Pricing– Rate Making in Life Insurance-objectives.

UNIT – III :

Health and Disability – Income – Insurance – Types of Individual Health Insurance Coverage – Individual Medical Expense, Contractual – Group Insurance Plans – Group Medical Expense Insurance.

UNIT – IV :

Employee Benefits – Retirement Plans – Fundamentals of Private Retirement Plans – Types of Qualified Retirement Plans – Profit Sharing Plans – Self Retirement Plans for Employed – Single Retirement Plans – Simplified Retirement Pension.

UNIT – V :

Re-insurance: Reasons for Reinsurance – Types of Reinsurance – Alternatives to Traditional Reinsurance – Functions of Reinsurance – Advantages and Disadvantages of Reinsurance.

Suggested Books:

1. George E Rejoa, Principles of Risk Management and Insurance, Pearson Education, New Delhi, 2004.
2. Black Jr Skipper Jr. Health Insurance, Pearson Delhi, 2003.
3. M.N.Mishra, Insurance Principles and Practices, S.Chand, New Delhi, 2003.
4. M.J.Mathew, Insurance Principles and Practices, RBSA Publishers, Jaipur, 2005.
5. M.Y. Khan “ Financial services, Tata Mcgraw Hill, New Delhi, 2008
6. Prof. N. Vijaya Ratnam & Prof. B. Mohan, Financial Services – Banking & Insurance, Telugu Academy, Hyderabad.

The Guidelines to be followed by the question paper setters in **CO407- INSURANCE PRODUCTS AND MANAGEMENT** for the fourth semester-end exams

PAPER TITLE:CO407- INSURANCE PRODUCTS AND MANAGEMENT

PAPER- VII Semester-IV Maximum Marks: 70 Duration: 3 Hours

Weight age for the question paper

Syllabus	Section –A (short answer questions) (with internal choice)	Section- B (Long answer questions) (with internal choice)	Section –C (essay question) (with internal choice)
Unit -1	1 (a or b)	1 (a or b)	Any unit
Unit -2	1 (a or b)	1 (a or b)	
Unit -3	1 (a or b)	1 (a or b)	
Unit -4	1 (a or b)	1 (a or b)	
Unit -5	1 (a or b)	1 (a or b)	

- CO 1 Each short answer question carries 4 marks in section-A.
- CO 2 Each long answer question carries 8 marks in section-B.
- CO 3 Each essay answer question carries 10 marks in section-C.

The Question Paper Setters are requested to cover all the topics in the syllabus stipulated as per the weightage given by us.

**A. G & S.G. SIDDHARTHA DEGREE COLLEGE OF ARTS & SCIENCE
(Autonomous), Vuyyuru-521165.**

**MODEL QUESTION PAPER
M.COM. (REGULAR) DEGREE EXAMINATION
Fourth Semester
CO407 – INSURANCE PRODUCTS AND MANAGEMENT
(2021-2022 Regulation Onwards)**

Duration: 3 hours

Maximum Marks: 70

SECTION- A

Answer All Questions

5×4=20 Marks

1. **Write Short Notes on:**
- i. a) Define Life Insurance. OR
b) Insurance Interest
 - ii. a) Dividend Options. OR
b) Insurance Pricing
 - iii. a) Explain types individual health insurance coverage OR
b) What is group insurance?
 - iv. a) What is retirement benefit? OR
b) Explain the types of qualified retirement plans.
 - v. a) Explain the types of reinsurance. OR
b) Explain the self retirement plans for employed.

SECTION – B

Answer All Questions

5×8=40 Marks

2. a) Explain the variations of whole life insurance.
OR
b) Explain the basic principles of life insurance.
3. a) Discuss the additional life insurance benefits.
OR
b) What is group insurance? Explain the various group insurance plans.
4. a) Explain the fundamentals of private retirement plans.
OR
b) Discuss the profit sharing plans.
5. a) Discuss the reasons for reinsurance.
OR
b) Explain the functions of reinsurance.
6. a) Discuss the objectives of rate making in life insurance.
OR
b) Explain the alternatives to traditional reinsurance.

SECTION C - (1 x 10=10 marks)

Answer the following question.

7. a) Discuss the other types of life insurance.
OR
b) Explain the dividend, non- forfeiture and settlement options in life insurance.

**A.G & S.G SIDDHARTHA DEGREE COLLEGE OF ARTS & SCIENCE,
VUYYURU-521165**

(An Autonomous College in the Jurisdiction of Krishna University) Accredited

at the level 'A' by the NAAC

Sponsors: Siddhartha Academy of General & Technical Education



DEPARTMENT OF COMPUTER SCIENCE

Minutes of the meeting of Board of Studies in Computer Science for PG (M.Sc.)

Date: 10-06-2022



A.G & S.G SIDDHARTHA DEGREE COLLEGE OF ARTS AND SCIENCE::VUYYURU

(An Autonomous College in the Jurisdiction of Krishna University)
Accredited at the level 'A' by the NAAC
Sponsors: Siddhartha Academy of General & Technical Education

DEPARTMENT OF COMPUTER SCIENCE (PG)

Minutes of the meeting of Board of Studies in Computer Science for M.Sc. (Computer Science) programme held on 10-06-2022 at 11:00A.M. for the Department of Computer Science.

Members Present		
Name of the Member	Role	Signature
Smt. T.Keerthi, I/C HOD, Dept. of Computer Science, A.G & S.G Siddhartha Degree College of Arts & Science, Vuyyuru-521165. Mobile: 9959558485 E-Mail: keerthitineni16@gmail.com	Chairman	
Dr. K.Madhavi, Associate Professor, Dept of Computer Science, JNTUA. College of Engineering, Anantapur. Mobile: 9440206501 E-Mail: kasamadhavi@yahoo.com	University Nominee, Krishna University	
Dr.R.Satya Prasad, Professor, Department of Computer Science, Acharya Nagarjuna University, Nagarjuna Nagar-522508. Mobile: 9848487478 E-Mail: profrsp@gmail.com	Subject Expert	
Dr.T.S.Ravi Kiran, H.O.D & Assistant Professor, Dept of Computer Science, P.B. Siddhartha Degree College of Arts & Science-Vijayawada -520002. Mobile: 9441176980 E-Mail: kirantsr1@gmail.com	Special Invitee	
Sri.U.Sairam, C.E.O, Codegnan I.T Solutions OPC PVT LTD., Vijayawada 520002 Mobile: 9959555952 E-Mail: uppugundlasairam@gmail.com	Industrialist	
Ms. P.Srujana, Software Developer, TonmetriInfoSolutions, Vijayawada. Mobile: 9032671688 E-Mail: srujanapaladugu26@gmail.com	Alumni Representative	
Smt. V. Munki, Assistant Professor, A.G & S.G Siddhartha Degree College of Arts & Science. Mobile: 8099205522 E-Mail: munki.j2ee@gmail.com	Member	
Sri.B.MadhuSudhana Rao, Assistant Professor, A.G & S.G Siddhartha Degree College of Arts & Science. Mobile: 7842664766 E-Mail: ms.madhu27@gmail.com	Member	

PG

AGENDA

- To discuss and approve the *Structure, Syllabi and Model Question Papers* of *Second Semester* of M.Sc.(Computer Science) for the batch of students admitted from the academic year 2021-2022 and onwards.
- To discuss and approve the *Structure, Syllabi and Model Question Papers* of *Fourth Semester* of M.Sc.(Computer Science) for the batch of students admitted from the academic year 2021-2022 and onwards.

RESOLUTIONS

- **Resolved and recommended to continue the same syllabus, model papers without changes in the Second Semester for the following courses:**
 - Computer Networks (21CS2T1)
 - Data Structures (21CS2T2)
 - Web Technologies (21CS2T3)
 - Operating System (21CS2T4)
 - Data Structures Lab (21CS2L2)
- **Resolved and recommended to introduce new syllabus, model papers in the Second Semester for the following courses:**
 - Computer Networks & Operating System Lab (21CS2L1)
- **To discuss and approve the *Structure, Syllabi and Model Question Papers* of Open Electives “*Computer Fundamentals & office Tools*” for Second Semester**
- **Resolved and recommended to continue the same syllabus, model papers without changes in the Fourth Semester for the following courses:**
 - Cloud Computing (21MCS403)
- **Resolved and recommended to introduce new syllabus, model papers in the Fourth Semester for the following courses:**
 - PHP & MY SQL (21MCS401)
 - Big Data & Analytics (21MCS402)
 - Artificial Intelligence & Machine Learning (21MCS404)
 - Big Data & Analytics Lab (21MCS402L1)
 - Project Work (21MCS405)

A.G & S.G Siddhartha Degree College of Arts & Science, Vuyyuru – 521165.
(An Autonomous College in the jurisdiction of Krishna University)
M.Sc., (Computer Science) Programme - II Semester

Course	COMPUTER NETWORKS		
Course Code	20CS2T1	Course Delivery Method	Class Room / Blended Mode
Credits	4	CIA Marks	30
No. of Lecture Hours / Week	4	Semester End Exam Marks	70
Total Number of Lecture Hours	60	Total Marks	100
Year of Introduction:2020-21	Year of Offering:2021-22	Year of Revision:2021-22	Percentage of Revision: 0%

1. Course Outcomes:

At the end of this course students will be able to:

1. Understand functionality of *Layered Network Architecture*, Different types of *Transmission Media*. (CO1)
2. Understand various *Networks* and their functions.(CO2)
3. Understand the *IPAddresses* and various *Routing Algorithms* used in internet networking.(CO3)
4. Understand different *Transport Layer Protocols*.(CO4)
5. Understand the various *Application Layer Protocols* and *Security Issues* over internet.(CO5)

Unit	Learning Units	Lecture Hours
I	<p>Introduction: Uses of Computer Networks: Business Application, Home Applications, Mobile Users, Social Issues,.</p> <p>Network Hardware: Local Area Networks, Metropolitan Area Networks, Wide Area Networks, Wireless Networks, Home Networks, Internetworks.</p> <p>Network Software: Protocol Hierarchies, Design Issues for the Layers, Connection Oriented and Connectionless Services, Service Primitives, The relationship of Services to Protocols,</p> <p>Reference Models: The OSI Reference Model, The TCP/IP Reference Model, A Comparison of OSI and TCP/IP Reference Model, A Critique of the OSI Model and Protocols, A Critique of the TCP/IP reference model,</p> <p>Example Networks: The Internet, The Third Generation Mobile Phone Networks, Wireless LANs, RFID and Sensor Networks.</p> <p>Physical Layer: Guided Transmission Media: Magnetic Media, Twisted Pair, Coaxial Cable, power lines, Fiber Optics</p>	14
II	<p>Data Link Layer: Data Link Layer Design Issues: Services Provided to the Network Layer, Framing, Error Control, and Flow Control.</p> <p>Error Correcting Codes, Error Detecting Codes, Elementary Data Link Protocols: An Utopian Simplex Protocol, A Simplex Stop and Wait Protocol, A Simplex Protocol for a Noisy Channel.</p> <p>Sliding Window Protocols: A One Bit Sliding Window Protocol, A Protocol Using Go Back N, A Protocol using Selective Repeat.</p> <p>The Medium Access Control Sub Layer: Ethernet: Ethernet Cabling, Manchester</p>	14

	<p>Encoding, The Ethernet MAC sub layer Protocol, The Binary Exponential Back off Algorithm, Ethernet Performance, Switched Ethernet, Fast Ethernet, Gigabit Ethernet, 10-bit Gigabit Ethernet.</p> <p>Wireless Lans: The 802.11 Protocol Stack, The 802.11 Physical Layer, The 802.11 MAC Sub Layer Protocol, The 802.11 Frame Structure, Bluetooth: Bluetooth Architecture, Bluetooth Applications, The Bluetooth Protocol Stack, The Bluetooth Radio Layer, The Bluetooth Link Layers, The Bluetooth Frame Structure,</p> <p>Data Link Layer Switching: Uses of Bridges, Learning Bridges, Spanning Tree Bridges, Remote Bridges, Repeaters, Hubs, Bridges, Switches, Routers and Gateways, Virtual LANs.</p>	
III	<p>The Network Layer: Network Layer Design Issues: Store and Forward Packet Switching, Services provided to the Transport Layer, Implementation of Connectionless Services, Implementation of Connection Oriented Services, Comparison of Virtual Circuit and Datagram subnets. Routing Algorithms : The Optimality Principle, Shortest Path Routing, Flooding, Distance Vector Routing, Link State Routing, Hierarchical Routing, Broadcast Routing, Multicast Routing.</p> <p>Internet Working: How Networks Differ, How Networks can be connected, Concatenated Virtual Circuits, Connectionless Internetworking, Tunneling, Internetwork Routing, Packet Fragmentation. The Network Layer in the Internet: The IP Version 4 Protocol, IP address, Internet Control Protocols, OSPF, The Internet Gateway Routing Protocol, BGP, The Exterior Gateway Routing Protocol.</p>	10
IV	<p>The Transport Layer: The Transport Service: Services provided to the Upper Layers, Transport Services Primitives, and Berkeley Sockets.</p> <p>Elements of Transport Protocols: Addressing, Connection Establishment, Connection Release, Flow Control and Buffering, Multiplexing.</p> <p>The Internet Transport Protocols: Introduction to UDP: Remote Procedure Call, The Real Time Transport Protocol.</p> <p>The Internet Transport Protocols: Introduction to TCP, The TCP Service Model, The TCP Protocol, The TCP Segment Header, TCP Connection Establishment, TCP Connection Release, Modelling TCP Connection Management, TCP Sliding Window, TCP Congestion Control, TCP Timer Management, Future of TCP.</p>	10
V	<p>The Application Layer: DNS: The Domain Name System: The DNS Name Space, Resource Records, Name Servers.</p> <p>Electronic Mail: Architecture and Services, The User Agent, Message Formats, Message Transfer, Final Delivery.</p> <p>The World Wide Web: Architecture Overview, Static Web Pages, Dynamic Web Pages and Web Applications. HTTP-The Hyper Text Transfer Protocol.</p> <p>Streaming Audio and Video: Digital Audio, Digital Video, Streaming Stored Media, Streaming Live Media, Real Time Conferencing.</p> <p>Network Security: Introduction to Cryptography, Public Key Algorithms-RSA.</p>	12

Prescribed Text Book

	Author	Title	Publisher
1	Andrews.T anenbaum	Computer Networks	Fifth Edition, Pearson Chapters: 1.1 to 1.5, 2.2, 3.1 to 3.4, 4.3, 4.4, 4.6, 4.8, 5.1, 5.2.1 to 5.2.8, 5.5, 5.6.1 to 5.6.4, 5.6.6, 5.6.7, 6.1.1 to 6.1.3, 6.2.1 to 6.2.5, 6.4, 6.5, 7.1, 7.2, 7.3.1 to 7.3.4, 7.4.1 to 7.4.5, 8.1.1, 8.3.1

Reference Text Book

1	Behrouz A Forouzan, Firouz	Computer Networks A Top Down Approach	McGraw hill Education (India) Special Indian Edition
---	----------------------------	---------------------------------------	--

	Mosharaff		
2	JamesF.Kurose,Keith W.Ross	Computer Networking- A Top-Down Approach	6e,Pearson
3	Larry Peterson and Bruce Davie	Computer Networks-A System Approach	5e,ElsevierIndia

A.G &S.G Siddhartha Degree College of Arts & Science, Vuyyuru - 521165.

(An Autonomous College in the jurisdiction of Krishna University)

M.Sc., (Computer Science) Programme-II Semester

Course Code: 20CS2T1

Title: COMPUTER NETWORK

Time: 3Hours

Max.Marks:70

SECTION-A

Answer ALL questions

(10×2=20Marks)

- 1a) Distinguish between *Computer Network* and *Distributed System*.(BTL4)
- b) What is *Bit Stuffing*? (BTL1)
- c) How *Ethernet Switch* works?(BTL1)
- d) What is *Ubiquitous Computing*? (BTL1)
- e) What is count to *Infinity Problem*? (BTL1)
- f) How *Router* works?(BTL1)
- g) What is *Berkley Socket*? (BTL1)
- h) What is *Port Mapper*? (BTL1)
- i) What are *Resource Records*? (BTL1)
- j) What is *POP3*? (BTL1)

SECTION-B

Answer Five Questions Choosing One Question from Each Unit.

All Questions Carry Equal Marks.

(5×10=50Marks)

UNIT-I

11a) Explain *OSI Reference Model* with neat diagram. (BTL2)

(OR)

B) Explain *Error Correction And Detection Codes* with example.(BTL2)

UNIT -II

12a) Explain *Sliding Window Protocol* with neat diagram. (BTL2)

(OR)

b) Explain *Bluetooth Architecture* and its *Protocol Stack* with neat diagram.(BTL2)

UNIT -III

13a) Explain any two *Dynamic Routing Algorithms*. (BTL2)

(OR)

B) Explain *IPV4 Packet Format* with neat diagram. (BTL2)

UNIT-IV

14a) Explain *Real Time Protocol*. (BTL2)

(OR)

b) Explain *Connection Establishment and Termination* with neat diagram.(BTL2)

UNIT-V

15a) Explain *Session Initiation Protocol*.(BTL2)

(OR)

b) Explain *HTTP Request* and *HTTP Response* Messages.(L2)

A.G&S.G Siddhartha Degree College of Arts & Science, Vuyyuru - 521165.
(An Autonomous College in the jurisdiction of Krishna University)
M.Sc., (Computer Science) Programme-II Semester

COURSE	COURSE CODE	L	T	P	C	Year
COMPUTER NETWORKS & OPERATING SYSTEMS LAB	20CS2L1	-	-	8	4	2020-21

Course Outcomes:

On successful completion of this course, the students:

- Practice *Unix Shell Scripting* and *AWK Programming*.(CO1)
- Apply *Operating System Scheduling Algorithms*.(CO2)
- Prepare *Patch Cards* and Implement *Network Monitoring Tools*.(CO3)
- Implement Network Programming to obtain *IP address, Machine Name* and *Communication* etc.(CO4)
- Design various networks with *CISCO Packet Tracer* and implement *Network Algorithms*.(CO5)

LAB LIST PART A

Shell Scripting

1. Introduction to basic UNIX commands.
2. Write a shell script to accept the name of the file from standard input and perform the following tests on whether the file exists, if exists test file permissions whether file is executable, readable, writable, both read & writable.
3. Write a script that will ask user, full name (first, middle, last name) greet user by first name. Ask users DOB and calculate user's age.
4. Write a shell script which will display Fibonacci series up to a given number of arguments.
5. Write a shell script to accept student number, name, and marks in 5 subjects. Find total, average and grade. Display the result of student and store in a file called stu.dat Rules: if avg >= 90 grade A+, 80-89 grade B+, 70-79 grade B, 69-69 grade C+, 51-50 grade C, 41-49 grade D else grade F
6. Write a shell script to accept empno, empname, and basic. Find DA, HRA, TA, PF using following rules. Display empno, empname, and basic, DA, HRA, PF, TA, GROSS SAL and NETSAL. Also store details in a file called emp.dat. Rules: DA is 18% of basic if basic > 5000 otherwise 550 DA is 35% of basic, PF is 12% of basic + DA, TA is 10% of basic.
7. Write a shell script to display reverse numbers from given arguments

AWK scripting

Write a wk script for the following

1. To print the numbers of even lines in a file.
2. To print the Numbers Of odd lines in A file.
3. To delete empty lines in a File.
4. To display lines having more than 60 characters.
5. To display the lines which match the multiple patterns?
6. To display the lines which do not match the Patterns?
7. To display the Lines or Records 5-9 both inclusive.
8. Write a wk script for the following
9. To display the lines between two patterns (both inclusive).
10. To display the specified line 5 or record in a file.
11. List out the files which are created in March.
12. Print the total size occupied by the files in your directory.
13. Print the all lines by changing into upper case.

14. Print line where fields have multiple field separators.
15. Write an awk program to display employee's pay bill (data file may be comma separated file containing (eno,name,basic) calculate DA,HRA,TA,PF(basic+da))

PART B

1. Scheduling algorithms (BTL3)
2. Write program to implement FCFS scheduling algorithm.
3. Write program to implement Round Robin scheduling algorithm.
4. Write program to implement SJF scheduling algorithm.

PART C

1. Study different type of Guided media .Coaxial, UTP & OFC
2. Prepare straight and cross wire cable and test it.
3. Study net work devices in detail (repeater, hub, switch, router, and gateway).
4. Study of IP address (IPV4 –classification, Sub netting, super netting, IPV6).
5. Connect the computers in a local area Network.
6. Study basic net work commands (ping ,finger ,ftp ,tracer oute ,ns lookup ,pathping, telnet,arp).

PART D(Implementing Python/Java)

1. Program to fetch the IP address of a system.
2. Program to obtain the information about the(a)Host (b)Port(c)protocol.
3. Write a program to accept the Website name and return its IP address.
4. Write a program to implement echo client and echo server.
5. Write a program to implement TCP client-server program.
6. Write a program to use Simple Mail Transfer Protocol.
7. Write a program to use the Domain Name System using UDP.
8. Implementation of sliding window protocol.
9. Find the subnet mask and Net work address fort hegiven IP address.

PART E (Using Cisco packet tracer 6.5 (freely available))

1. Configure a net work using a server with five no disusing packet tracer.
2. Configure a net work using a DHCP server with five no disusing packet tracer.
3. Configure a net work using two DHCP servers with no disusing packet tracer.
4. Configure a net work using three DHCP servers with nodes using packet tracer.
5. Configure a net work with DHCP servers with wired and wireless no des using Cisco packet tracer.
6. Exhibit spanning tree algorithms

A.G & S.G Siddhartha Degree College of Arts & Science, Vuyyuru – 521165.
(An Autonomous College in the jurisdiction of Krishna University)
M.Sc., (Computer Science) Programme - II Semester

Course	DATASTRUCTURES		
Course Code	20CS2T2	Course Delivery Method	Class Room / Blended
Credits	4	CIA Marks	30
No. of Lecture Hours / Week	4	Semester End Exam Marks	70
Total Number of Lecture Hours	60	Total Marks	100
Year of Introduction:2020-21	Year of Offering:2021-22	Year of Revision:2021-22	Percentage of Revision: 0%

Course Outcomes:

On successful completion of this course, the students:

1. To define data structures, operation of data structure, time and space complexities.(CO1)
2. To understand concepts of string processing, arrays, records and pointers, linked lists, stacks, queues, recursion, trees, graphs & searching techniques. about searching and sorting techniques.(CO2)
3. To implement applications of linked lists, stacks, queues, trees, graphs, sorting & searching techniques.(CO3)
4. To analyze applications of linked lists, stacks, queues, trees, graphs, sorting & searching techniques.(CO4)
5. To evaluate applications of linked lists, stacks, queues, trees, graphs, sorting & searching techniques in terms of time & space complexity.(CO5)

Unit	Title	Lecture Hours
I	Introduction and Overview: Elementary Data Organization, Data Structures, Data Structure operations, Algorithms: Complexity, Time-Space Trade off. Preliminaries: Mathematical Notation and Functions, Algorithmic Notation, Control Structures, Complexity of Algorithms, Other Asymptotic Notations, Sub Algorithms, Variables, Data Types.	14
II	String Processing: Storing Strings, Character Data Type, String Operations, Word Processing, Pattern Matching Algorithms. Arrays, Records and Pointers: Linear Arrays, Representation and Traversing Linear Arrays, Inserting and Deleting, Bubble Sort, Linear Search, Binary Search, Multidimensional Arrays, Pointer Arrays, Record Structures, Representation of records in memory, Parallel Arrays, Matrices, Sparse Matrices.	14
III	Linked Lists: Representation, Traversing, Searching, Memory Allocation: Garbage Collection, Insertion, Deletion, Header Linked Lists, Two-Way Lists. Stacks, Queues, Recursion: Stacks, Array representation, Linked List representation, Arithmetic Expressions; Polish notation, Quick Sort, Recursion, Towers of Hanoi, Implementation of recursive procedures by stacks, Queues, Linked representation of Queues, De-queues, Priority Queues.	14

IV	<p>Trees: Binary Trees, Representing and Traversing Binary trees, Traversal Algorithms Using Stacks, Header Nodes, Binary Search Trees, Searching, Insertion and deletion in Binary Search Trees, AVL Search Trees, Insertion and Deletion in AVL Search Trees, M-way Search Trees, Searching, Insertion and Deletion in M-way Search Trees, B-Trees, Searching, Insertion and Deletion in B-Trees, Heap: Heap Sort, Huffman's Algorithms, General Trees.</p>	14
V	<p>Graphs: Terminology, Sequential representation of Graphs, Warshall's Algorithm, Linked Representation of Graphs, Operations on Graphs, Traversing a Graph, Topological sorting.</p> <p>Sorting and Searching: Insertion Sort, Selection Sort, Merging, Merge Sort, Radix Sort, Searching and Data Modification, Hashing.</p>	14

Prescribed Text Book

	Author	Title	Publisher
1	Seymour Lipschutz	Data Structures	The Mc Graw Hill(Schaum's Outlines), 2011

Reference Text Books

	Author	Title	Publisher
1	Seymour Lipschutz	Theory and Problems of Data Structures	The Mc Graw Hill(Schaum's Outlines)
2	Aho, Hopcroft & Ullman	Data Structures & Algorithms	Addison-Wesley
3	M.A.Weiss	Data Structures & Algorithms in C	Addison Wesley

A.G&S.G Siddhartha Degree College of Arts & Science, Vuyyuru - 521165.
(An Autonomous College in the jurisdiction of Krishna University)
M.Sc., (Computer Science) Programme-II Semester

Course Code: 20CS2T2

Title: DATA STRUCTURES

Time: 3Hours

Max.Marks:70

SECTION-A

Answer ALL questions

(10×2=20Marks)

1. Define *Data Structures*.(BTL1)
2. What is *Space Complexity*? (BTL1)
3. What is *Linear Array*?(BTL1)
4. What is *Sparse Matrix*?(BTL1)
5. Define a *Priority Queue*.(BTL1)
6. What is *Garbage Collection*?(BTL1)
7. Define a *Binary Tree*.(BTL1)
8. Define *AVL Tree*. (BTL1)
9. Define *Graph*.(BTL1)
10. What is *Sorting*?(BTL1)

SECTION-B

Answer Five Questions Choosing One Question from Each Unit.

All Questions Carry Equal Marks

(5x10=50Marks)

UNIT-I

11a) Discuss *Elementary Data Organization and Data Structure Operations*.(BTL6)

(OR)

b) Explain various *Control Structures*.(BTL2)

UNIT-II

12a) Explain *Binary Search Algorithm and Linear Search Algorithm* with an example.(BTL2)

(OR)

b) Discuss *The Second Pattern Matching Algorithm* with example.(BTL6)

UNIT-III

13a). Explain *Quick Sort Algorithm* with example.(BTL2)

(OR)

b) Explain *Operations of Stack* and its representation using *Linked List* and *Array* with example.(BTL2)

UNIT-IV

14a) Discuss *Binary Tree Traversal Techniques* using *Stack* in detail.(BTL6)

(OR)

B) Briefly discuss about the *insertion and deletion operations of Binary Search Trees* With example.(BTL6)

UNIT-V

15a) Explain the process of *Topological Sorting*.(BTL2)

(OR)

b) Discuss about *Merge Sort* with an example.(BTL6)

A.G&S.G Siddhartha Degree College of Arts & Science, Vuyyuru - 521165.

(An Autonomous College in the jurisdiction of Krishna University)

M.Sc., (Computer Science) Programme-II Semester

COURSE	COURSE CODE	L	T	P	C	Year
DATASTRUCTURESLAB	20CS2L2	-	-	8	4	2020-21

Course Outcomes:

- On successful completion of this course ,the students:
- Understands the concept of Stacks, Queues, and Tree Traversals.(CO1)
- ApplytheoperationsofSinglyLinkedLists,DoublyLinkedLists,CircularLinkedListsandOperationsonStacksandQueues.(CO2)
- ApplyoperationsonBinarySearchTree,BinarySearchTreeTraversals,SparseMatrixandDFS&BFSAlgorithm.(CO3)
- Implement Searching& Sorting Algorithms.(CO4)
- Implement AVL-Trees and B-Trees.(CO5)

CYCLE1

1. Write a Java Program to create class called Stack and implement Stack Operations.
2. Write a Java Program to create a class called Queue and implement Stack Operations.
3. Write a Java Program to convert the Infix to Postfix Expression.
4. Write a Java Program to evaluate Post fix Expression.
5. Write a Java Program to obtain the Binary Number for a given Decimal Number.

CYCLE 2

1. Write a Java Class to implement the operations of a Singly Linked List.
2. Write a Java Class to implement the operations of a Doubly Linked List.
3. Write a Java Class to implement the operations of a Circular Linked List.
4. Write a java program for the following a) Reverse a Linked List b)Sort the data in a Linked List c)Remove Duplicates d)Merge Two Linked Lists
5. Write a java program for performing various operations on Stack using Linked List.
- 6 . Write a java program for performing various operations on Queue using Linked List.

CYCLE 3

1. Write a Java Program to implement operations on Binary Trees Using Recursive and Non-Recursive Methods.
2. Write a Java Program to perform Binary Search Tree Traversal.
3. Write a Java Program to implement Sparse Matrix.
4. Write a Java Program to implement DFS Algorithm.
5. Write a Java Program to implement BFS Algorithm.

CYCLE4

1. Write a Java Program to implement the following sorting techniques:
a.Bubble Sort b. Merge Sort. c. Quick Sort. d. Heap Sort.
2. Write a java program to implement Quick Sort of given elements.
3. Write a Java Program to implement the Following search techniques:
a. Linear Search b. Binary Search

CYCLE5

1. Write a java program to implement various operations on AVL Trees.
2. Write a java program to perform the following operations
a) Insertion in to a B-Tree b) Searching in a B-Tree

A.G & S.G Siddhartha Degree College of Arts & Science, Vuyyuru – 521165.
(An Autonomous College in the jurisdiction of Krishna University)
M.Sc., (Computer Science) Programme - I Semester

Course	WEB TECHNOLOGIES		
Course Code	20CS2T3	Course Delivery Method	Class Room / Blended
Credits	4	CIA Marks	30
No. of Lecture Hours / Week	4	Semester End Exam	70
Total Number of Lecture Hours	60	Total Marks	100
Year of Introduction:2020-	Year of Offering:2021-22	Year of Revision:2021-22	Percentage of Revision:

Course Outcomes:

On successful completion of this course, the students:

1. Students are able to describe the concepts of WWW including browser and HTTP protocol and various HTML tags and use them to develop the user friendly WebPages.(CO1)
2. Students will be able to use the Java Script and VBScript to develop the dynamic WebPages.(CO2)
3. Students will be able to define the CSS with its types and develop the modern web pages using the HTML and XML elements with different layouts as per need of applications.(CO3)
4. Students use server side scripting with PHP to generate the web pages dynamically using the database connectivity.(CO4)
5. Develop the modern Web applications using the client and server side technologies and the web design fundamentals.(CO5)

Unit	Learning Units	Lecture Hours
I	<p>Introduction: What is Internet, History of Internet, Internet Services and Accessibility, Uses of the Internet, Protocols, Web Concepts: The Client/Server Model, Retrieving Data from the Web, How the Web Works?, Web Browsers, Searching information on the Web, Internet Standards.</p> <p>HTML: Outline of an HTML Document, Head Section Body Section: Headers, Paragraphs, Text Formatting, Linking, Internal Linking, Embedded Images, Lists, Tables, Frames, Other Special Tags and Characters, HTML Forms.</p>	12
II	<p>Java Script: Introduction to Scripting, Control Statements I, Control Statements II, Functions, Arrays, Objects, Document Object Model, Events.</p> <p>VB Script: Introduction, Embedded VBScript code in an HTML Document, Comments, Variables, Array Variables, Operator, Assignment Operators, Numerical Operators, String Concatenation, Procedures, Sub Procedure, Function Procedure, Conditional Statements, Looping Statements, Object and VB script, Cookies, Cookie Variables, Creating a Cookie, A Cookie with Multiple Values, Reading Cookie Value.</p>	12

III	<p>Dynamic HTML (DHTML): Introduction, Cascading Style Sheets (CSS), Coding CSS, Properties of Tags, Property Values, Other Style Properties, In Line Style Sheets, Embedded Style Sheets, External Style Sheets, Grouping, Inheritance, Class as Selector, ID as Selector, Contextual Selector, Pseudo Classes and Pseudo Elements, Positioning, Backgrounds, Element Dimensions, DHTML Document Object Model and Collections, Using the Collections All, Moving Object around the Document, Event Handling, Assigning Event Handlers, Event Bubbling, Filters and Transition Filters, Transitions, Data Binding, Using Tabular Data Control, Sorting Data, Dynamic Sorting, Filtering.</p> <p>XML: Introduction, HTML Vs. XML, syntax of XML document, XML attributes, use of elements Vs. use of attributes, XML validation, well formed XML documents, valid XML documents.</p> <p>XML DTD: Internal DTD, External DTD, the building blocks of XML documents.</p> <p>DTD Elements: Declaring an Element, Empty Elements, Elements with data, Elements with Children, Wrapping, Declaring only one occurrence of the same Elements, Declaring minimum one occurrence of the same Element, defining Zero or One occurrence of the same element, declaring mixed content.</p> <p>DTD Attributes: Declaring Attributes, Default Attribute Value, Implied Attribute, Required Attribute, Fixed Attribute Value, Enumerated Attribute Values, DTD Entries, DTD Validation, XSL, XSL Transformation, XSL Name Spaces, XML Schema.</p>	12
IV	<p>Servlets: Introduction, Advantages of Servlets over CGI, Installing Servlets, The Servlet Life Cycle, Servlets API, A Simple Servlet, Handling HTTP <i>Get</i> requests, Handling HTTP Post Requests, Cookies, Session Tracking, Multi Tier Applications using Database Connectivity, Servlets Chaining.</p> <p>PHP: Introduction ,PHP basics, String Processing and Regular Expressions, Form Processing and Business Logic, Connecting to a Database, Using Cookies, Dynamic Content, Operator Precedence Chart.</p>	12
V	<p>Java Server Pages (JSP): Introduction, Advantages of JSP, Developing first JSP, Components of JSP, Reading Request Information, Retrieving the Data Posted from a HTML File to a JSP File, JSP Sessions, Cookies, Disabling Sessions.</p> <p>Active Server Pages (ASP):Introduction, Advantages of ASP, First ASP Script, Processing ASP Scripts with Forms, Variables and Constructs, Subroutines, Include/Virtual, ASP Cookies, ASP Objects, Connecting to Data with ASP.</p>	12

Prescribed Text Book

	Author	Title	Publisher
1	N.P.Gopalan, J.Akilandeswari	Web Technologies-A Developer's Perspective	PHI(2008)
2	HarveyM.DeitelandPaulI.Deitel	InternetandWorldWideWebHowToProgram,5e	PrenticeHall;4th edition

Reference books

1	Robert W.Sebesta	Programming the world wide web.	Third Edition,
2	Anders Moller and Michaelschwarzbach	An Introduction to XML and web Technologies.	Addison Wesley (2006)

A.G&S.G Siddhartha Degree College of Arts & Science, Vuyyuru - 521165.

(An Autonomous College in the jurisdiction of Krishna University)

M.Sc.,(Computer Science)Programme-II Semester

Course Code: 20CS2T3

Title: WEB TECHNOLOGIES

Time: 3Hours

Max.Marks:70

Answer ALL questions

(10×2=20Marks)

1. Write about *HTTP*.(BTL1)
2. Explain *TABLE* tag.(BTL2)
3. What are *Identifiers* in JavaScript?(BTL1)
4. Write the syntax of *VB Script*.(BTL1)
5. What is a *Valid XML document*?(BTL1)
6. Explain *Event Bubbling*.(BTL2)
7. What is a *Servlet*? (BTL1)
8. What are *Regular Expressions* in PHP?(BTL1)
9. What are *Scripts*?(BTL1)
10. Write about *Subroutines*.(BTL1)

Answer Five Questions Choosing One Question from Each Unit.

All Questions Carry Equal Marks.

(5×10=50Marks)

UNIT-I

11a)What is Internet? Explain Services of Internet.(BTL1)

Or

b) Illustrate Frame Set and Frame Attributes by writing program.(BTL2)

UNIT-II

12a)Explain the scope of Java Scrip Variables with example.(BTL2)

Or

b)Explain Document Object Model in Java Script briefly.(BTL2)

UNIT-III

13a)Discuss building an External Style Sheet. Explain advantages and disadvantages of External Style Sheets with an example.(BTL6)

Or

What is DTD? Explain the building blocks of DTD.(BTL1)

UNIT-IV

14a) Explain the Life Cycle of Servlets. Write the session tracker that tracks the number of access and last access of data of a particular webpage.(BTL2)

Or

b) Explain String Processing and Regular Expressions.(BTL2)

UNIT-V

15a) Explain Components of JSP and write a JSP Program to accept username and password from user and Validate them.(BTL2)

Or

b)Explain Processing *ASP Scripts* with *Forms*.(BTL2)

A.G & S.G Siddhartha Degree College of Arts & Science, Vuyyuru – 521165.
(An Autonomous College in the jurisdiction of Krishna University)
M.Sc., (Computer Science) Programme - II Semester

Course	OPERATING SYSTEMS		
Course Code	20CS2T4	Course Delivery Method	Class Room / Blended Mode
Credits	4	CIA Marks	30
No. of Lecture Hours / Week	4	Semester End Exam Marks	70
Total Number of Lecture Hours	60	Total Marks	100
Year of Introduction:2020-21	Year of Offering:2021-22	Year of Revision:2021-22	Percentage of Revision: 0%

Course Outcomes:

On successful completion of this course, the students:

1. Understand the Basic Concepts of Operating System, Operating System Structure and Process Concept.(CO1)
2. Applying concepts of Threads, Process Synchronization & CPU Scheduling.(CO2)
3. Understand Deadlock, Main Memory & Virtual Memory.(CO3)
4. Explain Mass Storage Structure, File System Interface & File System Implementation.(CO4)
5. Understanding on I/O Systems, Protection & Security.(CO5)

Unit	Learning Units	Lecture Hours
I	<p>Introduction: What Operating Systems Do Computer System Organization, Computer System Architecture, Operating System Structure, Operating System Operations, Process Management, Memory Management, Storage Management, Protection and Security, Kernel Data Structures, Computing Environments, and Open Source Operating Systems?</p> <p>Operating-System Structures: Operating System Services, User and Operating System Interface, System Calls, Types of System Calls, System Programs, Operating System Design and Implementation, Operating System Structure.</p> <p>Processes: Process Concept, Process Scheduling, Operations on Processes, Inter Process Communication, Communication in Client-Server Systems.</p>	12
II	<p>Threads: Overview, Multi core Programming, Multithreading Models, Thread Libraries, Implicit Threading, and Threading Issues.</p> <p>Process Synchronization: Background, The Critical Section Problem, Peterson's Solution, Synchronization Hardware, Mutex Locks, Semaphores, Classic Problems of Synchronization, Monitors.</p> <p>CPU Scheduling: Basic Concepts, Scheduling Criteria, Scheduling Algorithms, Thread Scheduling, Multiple Processor Scheduling.</p>	10

III	<p>Deadlocks: System Model, Deadlock Characterization, Methods for Handling Deadlocks, Deadlock Prevention, Deadlock Avoidance, Deadlock Detection, Recovery from Deadlock.</p> <p>Main Memory: Swapping, Contiguous Memory Allocation, Segmentation, Paging, Structure of the Page Table, Intel32 and 64-bit Architectures.</p> <p>Virtual Memory: Background, Demand Paging, Copy-on-Write, Page Replacement, Allocation of Frames, Thrashing.</p>	14
IV	<p>Mass Storage Structure: Overview of Mass Storage Structure, Disk Structure, Disk Attachment, Disk Scheduling, Swap Space Management, RAID Structure.</p> <p>File System Interface: File Concept, Access Methods, Directory and Disk Structure, File System Mounting Protection.</p> <p>File System Implementation: File System Structure, File System Implementation, Directory Implementation, Allocation Methods, Free Space Management Efficiency and Performance Recovery.</p>	10
V	<p>I/O Systems: Hardware, Application I/O Interface, Kernel I/O Subsystem, Transforming I/O Requests to Hardware Operations, STREAMS, Performance.</p> <p>Protection: Goals of Protection, Principles of Protection, Domain of Protection, Access Matrix, Implementation of the Access Matrix.</p> <p>Security: The Security Problem, Program Threats, System and Network Threats, Cryptography as a Security Tool, User Authentication, Firewalling to Protect Systems and Networks.</p>	14

Prescribed Text Book

	Author	Title	Publisher
1	Abraham Silbers chatz,	Operating Concepts	System

Reference Text Books

	Author	Title	Publisher
1	William Stallings	Operating Systems-Internals and Design Principles	Fifth(2007)
2	Achyut God bole	Operating Systems	Operating Systems
3	Flynn/McHoes	Operating Systems	Cengage Learning (2008).

(An Autonomous College in the jurisdiction of Krishna University)

M.Sc.,(Computer Science)Programme-II Semester

Course Code: 20CS2T4

Title: OPERATING SYSTEMS

Time: 3Hours Max.Marks:70

Answer ALL questions

(10×2=20Marks)

- 1a) Define *Kernel*(BTL1)
- b) What is *Process* (BTL1)
- c) What is *Deadlock*?(BTL1)
- d) What is *Semaphore*? (BTL1)
- e) What is *Multithreading*?(BTL1)
- f) What is *Swapping*?(BTL1)
- g) Describe any two *File Operations*.(BTL2)
- h) What is *File Pointer*? (BTL1)
- i) What is *Spooling*?(BTL1)
- j) What is *Access Matrix*? (BTL1)

Answer Five Questions Choosing One Question from Each Unit.

All Questions Carry Equal Marks.

(5×10=50Marks)

UNIT-I

2a) Explain *Operating System Services*.(BTL2)

(OR)

b) Explain various aspects of *Interposes Communication*.(BTL2)

UNIT-II

3a) Describe the *Dining Philosophers Problem* of Process Synchronization.(BTL2)

(OR)

b) Demonstrate (BTL2)

First-Come, First-Served Scheduling with the following data

Process	Burst Time
P1	24
P2	3
P3	3

Shortest-Job-First Scheduling with following data

Process	Burst Time
P1	6
P2	8
P3	7
P4	3

UNIT-III

4a) What are the *Necessary and Conditions* for *Dead Lock Situation* and also state methods for *Deadlock Prevention*.(BTL

(OR)

b) With reference string 7, 0, 1, 2, 0, 3, 0, 4, 2, 3, 0, 3, 2, 1, 2, 0, 1, 7, 0, 1 for a memory with three frames implement *Optimal Page Replacement* and *LRU Page Replacement*.(BTL4)

UNIT-IV

5a) Describe various levels of RAID. (BTL2)

(OR)

b) Describe various *Allocation Methods* of *File System Implementation*.(BTL2)

UNIT-V

6a) Explain the concepts of STREAMS in detail.(BTL2)

(OR)

b) What is Encryption? Describe *Symmetric Encryption* & *Asymmetric Encryption* in Detail. (BTL1)

A.G&S.G Siddhartha Degree College of Arts & Science, Vuyyuru - 521165.
(An Autonomous College in the jurisdiction of Krishna University)
Open Elective-II Semester

COURSE	COURSE CODE	L	T	P	C	Year
DATAVISUALIZATION	20CS2OEL1	4	-	-	4	2020-21

Course Outcomes:

After completion of the course the student will be able:

- To know the importance of *Data Visualization* in the world of *Data Analytics* and *Prediction*.
- To get familiarized about creating visualization using *Different Types of Charts*.
- To know creating and handling *Tables* in Tableau.
- To gain knowledge about using *Maps* in Tableau
- To gain knowledge about *Adhoc Analysis*.

UNIT I:

Creating Visual Analytics with Tableau Desktop, Connecting to Your Data - How To Connect To Your Data, What Are Generated Values?, Knowing When to use a Direct Connection, Joining Tables With Tableau, Blending Different Data Sources in a Single Worksheet.

UNIT II:

Building Your First Visualization-How Me Works-Chart Types, Text Tables, Maps, Bar Chart, Line Charts, Area Fill Charts and Pie Charts, Scatter Plot, Bullet Graph, Gantt Charts, Sorting Data In Tableau, Enhancing Views With Filters, Sets Groups and Hierarchies.

UNIT III:

Creating Calculations to enhance Your Data - What is Aggregation, What are Calculated Values and Table Calculations, Using the Calculation Dialog Box to Create, Building Formulas Using Table Calculations, Using Table Calculation Functions.

UNIT IV:

Using Maps to Improve Insights - Create a Standard Map View, Plotting Your Own Locations on a Map, Replace Tableau's Standard Maps, and Shaping Data to enable Point-to-Point Mapping.

UNIT V:

Developing an Adhoc Analysis Environment - Generating New Data with Forecasts, Providing Self Evidence Adhoc Analysis with Parameters, Editing Views in Tableau Server.

Prescribed Text Book			
	Author	Title	Publisher
1	Daniel G. Murray and the Inter Works BI Team	Tableau Your Data	Wiley Publications

Reference Text Books			
	Author	Title	Publisher
1	Ashutosh Nandeshwar	Tableau Data Visualization Cookbook	PACKT Publishing
2	Cole Nussbaumer, Knaflic	Storytelling with Data : A Data Visualization Guide for Business Professionals	Wiley Publishing

A.G&S.G Siddhartha Degree College of Arts & Science, Vuyyuru - 521165.
(An Autonomous College in the jurisdiction of Krishna University)
OPEN ELECTIVE

Course Code: 20CS2OEL1

Title: DATAVISUALIZATION

Time: 3Hours

Max.Marks:70

Answer ALL questions

(10×2=20Marks)

1. What is *Analytics*?(BTL1)
2. Explain *Data*.(BTL2)
3. What is *Filter*?(BTL1)
4. Explain *Set*.(BTL2)
5. Explain *Aggregation*.(BTL2)
6. What is *Calculated Value*?(BTL1)
7. What is a *View*? (BTL1)
8. Explain *Standard Map*.(BTL2)
9. What is *Forecast*?(BTL1)
10. What is *Analysis*?(BTL1)

Answer Five Questions Choosing One Question from Each Unit.

All Questions Carry Equal Marks.

(5×10=50Marks)

UNIT-I

11a) what are generated values? (BTL1)

(OR)

b) Explain Joining Tables with Tableau. (BTL2)

UNIT-II

12a).How to build visualization using *Text Tables, Maps, Bar Chart, Line Charts*.(BTL1)

(OR)

b).Explain *Sorting Data* in Tableau.(BTL2)

UNIT-III

13a).What is *Building Formulas* using *Table Calculations*? (BTL1)

(OR)

b).Write about *Creating Calculations* to enhance your data and *Table Calculations*.(BTL1)

UNIT-IV

14a).Explain *Plotting Your Own Locations* on a Map.(BTL2)

(OR)

b).How to Replace Tableau's *Standard Maps*? (BTL2)

UNIT-V

15a) Explain Developing an *Adhoc Analysis Environment* and how to generate *New Data from Forecasts*.(BTL2)

(OR)

b).How to provide *Self Evidence Adhoc Analysis* with *Parameters*.(BTL1)

A.G & S.G Siddhartha Degree College of Arts & Science, Vuyyuru – 521165.(An Autonomous College in the jurisdiction of Krishna University)
M.Sc., (Computer Science) Programme – IV Semester

M.Sc(Cs)	IV	MOOCS	21MCS401	2020-21
----------	----	-------	----------	---------

Total No of Hours for Teaching – Learning	Instructional Hours for Week		Duration of Semester End Examination in Hours	Max Marks		Credits
	Theory	Practical		CIA	SEE	
60 Hours	4	-	3 Hours	30	70	4

Course Objectives

The Main Course Objective is to give knowledge for Students on MOOC’S Courses

Course Outcomes

After Studying this Paper Student will acquire knowledge about MOOC’s Courses

- The Student has to enroll and complete any one of the **Computer Related Course (4 Credits Equivalent)** from MOOC’s platforms like NPTEL, SWAYAM etc.
- The Student is expected to submit the above course pass certificate otherwise, the Department of M.Sc (cs) will conduct the evaluation (as per the prescribed format in the academic regulations) to issue the pass certificate.
- The selection of the course by the student can be done under the supervision of mentor.

A.G & S.G Siddhartha Degree College of Arts & Science, Vuyyuru – 521165.

(An Autonomous College in the jurisdiction of Krishna University)

M.Sc., (Computer Science) Programme – IV Semester

Course	MOOCS		
Course Code	21MCS401	Course Delivery Method	Class Room / Blended Mode
Credits	4	CIA Marks	30
No. of Lecture Hours /Week	4	Semester End Exam Marks	70
Total No.of Lecture Hours	-	Total Marks	100
Year of Introduction:2020-21	Year of Offering:2021-22	Year of Revision:2021-22	Percentage of Revision: 0%

COURSE OUTCOMES

CO1: To introduce the concept of PHP and to give basic Knowledge of PHP.

CO2: Learn about PHP Syntax., Arrays, PHP Loops,

CO3: Understood the PHP form handling.

CO4: Understand Working with Files and Directories:

Co5: Understand basic concepts of MySql and PHPMyAdmin, how a database stores information via tables, Understanding of SQL syntax used with MySQL, Review of some sample PHP projects interacting with MySQL

MODULE 1 Installing and Configuring MySQL:

10 Hrs

Current and Future Versions of MySQL, How to Get MySQL, Installing MySQL on Windows, Trouble Shooting your Installation, Basic Security Guidelines, Introducing MySQL Privilege System, Working with User Privileges. Installing and Configuring Apache: Current and future versions of Apache, Installing Apache on Windows, Apache Configuration File Structure, Apache Log Files, Apache Related Commands, Trouble Shooting. Installing and Configuring PHP: Building PHP with Apache on Windows, The Building blocks of PHP: Variables, Data Types, Operators and Expressions, Constants. Flow Control Functions in PHP: Switching Flow Loops.

MODULE 2 – Working with Functions and Arrays:

10 Hrs

Calling functions, Defining Functions, Returning the values from User-Defined Functions, Variable Scope. Working with Arrays: Creating Arrays, Some Array-Related Functions. Working with Objects: Creating Objects, Object Instance Working with Strings, Dates and Time: Formatting Strings with PHP, Manipulating Strings with PHP, Using Date and Time Functions in PHP.

MODULE – 3 Working with Forms:

15Hrs

Creating Forms, Accessing Form – Input with User defined Arrays, Combining HTML and PHP code on a single Page, Sending Mail on Form Submission, Working with File Uploads. Working with Cookies and User Sessions: Introducing Cookies, Setting a Cookie with PHP, Session Function Overview, Starting a Session, Working with session variables, passing session Ids in the Query String, Destroying Sessions and Unsetting Variables

MODULE – 4 : Working with Files and Directories:

10Hrs

Including Files with include(), Validating Files, Creating and Deleting Files, Opening a File for Writing, Reading or Appending, Reading from Files, Writing or Appending to a File, Working with Directories, Open Pipes to and from Process Using popen (), Running Commands with exec(), Running Commands with system () or passthru (). Working with Images: Understanding the Image-Creation Process, Drawing a New Image, Getting Fancy with Pie Charts, Modifying Existing Images, Image Creation from User Input.

MODULE – 5 : Interacting with MySQL using PHP:

15 Hrs

Introduction to My SQL and Interfacing with Databases through PHP understanding the database design process: The Importance of Good Database Design, Types of Table Relationships, Normalization. Learning basic SQL Commands: Learning the MySQL Data types, Learning the Table Creation Syntax, Using Insert Command, Using SELECT Command, Using WHERE in your Queries, Selecting from Multiple Tables, Using the UPDATE command to modify records, Using REPLACE Command, Using the DELETE Command, Frequently used string functions in MySQL, Using Date and Time Functions in MySQL. Interacting with MySQL using PHP: MySQL Versus MySQLi Functions, Connecting to MySQL with PHP, Working with MySQL Data.

References:

1. Julie C. Meloni, PHP MySQL and Apache, SAMS Teach yourself, Pearson Education (2007).
2. Xue Bai Michael Ekedahl, The web warrior guide to Web Programming, Thomson (2006)

A.G & S.G Siddhartha Degree College of Arts & Science, Vuyyuru – 521165.
(An Autonomous College in the jurisdiction of Krishna University)
M.Sc., (Computer Science) Programme – IV Semester

Course Code: 21MCS401

Title: PHP MYSQL

Time: 3Hours

Max.Marks:70

SECTION-A

Answer ALL questions

(10x2 = 20 Marks)

1. a). What is PHP?
- b). List out PHP Data types?
- c). Define function?
- d). Describe objects?
- e). List out string functions?
- f). What is Cookie?
- g). how to create an image?
- h).what are the different types of table relationships?
- i). Write a syntax of Update command.
- j). differences between MYSQL and MYSQLi functions?

SECTION-B

Answer Five Questions Choosing One Question from Each Unit.

All Questions Carry Equal Marks.

(5×10=50Marks)

UNIT -I

2. a) Write a procedure to install PHP on windows
 (or)
 b) Explain flow control statements in PHP?

UNIT -II

3. a) Explain about arrays?
 (or)
 b) Explain about date and time functions in PHP.

UNIT -III

4. a) What is form? How to create and accessing a form with an Example.
 (or)
 b) What is Session? How to start and destroy sessions in PHP.

UNIT -IV

5. a) Explain about files?
 (or)
 b) Explain about working with Directories.

UNIT -V

6. a) Write about MySQL DDL and DML Commands?
 (or)
 b) How to connect with MYSQL with PHP

A.G & S.G Siddhartha Degree College of Arts & Science, Vuyyuru – 521165.
(An Autonomous College in the jurisdiction of Krishna University)
M.Sc., (Computer Science) Programme – IV Semester

Course	BIG DATA AND ANALYTICS		
Course Code	21MCS402	Course Delivery Method	Class Room / Blended
Credits	4	CIA Marks	30
No. of Lecture Hours / Week	4	Semester End Exam Marks	70
Total Number of Lecture Hours	60	Total Marks	100
Year of Introduction:2020-	Year of Offering:2021-22	Year of Revision:2021-22	Percentage of Revision: 0%

Course Outcomes:

On successful completion of this course, the students:

- Understand basics of Big Data. (CO1)
- Gain knowledge on *Big Data Analytics*. (CO2)
- Be familiar with *HDFS, and Hadoop environment*. (CO3)
- Have knowledge on Mongo DB. (CO4)
- Gain knowledge on PIG and Jasper soft. (CO5)

Unit	Learning Units	LH
I	Types of Digital data: Classification of Digital Data. Introduction to Big Data: Characteristics of data, Evolution of Big Data, Definition of big data, Challenges with Big data, What is Big Data?, Why Big Data?, Traditional Business Intelligence versus Big Data, A typical Data Warehouse Environment, A typical Hadoop Environment.	12
II	Big data analytics: What is Big Data Analytics?, Top challenges facing Big Data Analytics, Why Big Data Analytics is important?, Data Science, Terminologies used in Big Data Environments.	10
III	The Big Data Technology Landscape: No-SQL, Hadoop, Why Hadoop?, Why not RDBMS?, RDBMS versus Hadoop, Hadoop Overview, HDFS, Processing Data with Hadoop, Interacting with Hadoop Ecosystem.	14
IV	Introduction to Mongo DB: What is Mongo DB?, Why Mongo DB?, Terms used in RDBMS and Mongo DB, Data types in Mongo DB, Mongo DB query language. Introduction to Map reduce programming: Introduction, Mapper, Reducer, Combiner, Practitioner, Searching, Sorting and Compression.	10

V	<p>Introduction to Pig: What is Pig?, Pig on Hadoop, Pig Latin Overview, Data Types in Pig, Running Pig, Execution Modes of Pig, HDFS commands, Relational Operators, Eval function, Complex Data Types, User-Defined Functions, Parameter Substitution, Word Count Example using Pig.</p> <p>Jasper Report using Jasper soft: Introduction to Jasper Reports, Connecting to Mongo DB No-SQL Database.</p>	14
---	--	----

Prescribed Text Book

	Author	Title	Publisher
1	Seema Acharya and Subhashini Chellappan	Big Data and Analytics	Wiley India Pvt. Ltd., 2016

A.G & S.G Siddhartha Degree College of Arts & Science, Vuyyuru – 521165.
(An Autonomous College in the jurisdiction of Krishna University)
M.Sc., (Computer Science) Programme – IV Semester

Course Code: 20MCS402

Title: BIG DATA AND ANALYTICS

Time: 3Hours

Max.Marks:70

SECTION-A

Answer ALL questions

(10x2 = 20 Marks)

1.
 - a). Define big data?
 - b). Describe any five characteristics of big data
 - c). what is HDFS? List and Explain all the components of HDFS
 - d). Explain different challenges in Big data?
 - e). what is Mango DB?
 - f) Write Differences between RDBMS and Hadoop?
 - g) What is Map Reduce?
 - h) What is Data Serialization?
 - i) What is Yarn?
 - j) Explain the need of big data Analytics

SECTION-B

Answer Five Questions Choosing One Question from Each Unit.

All Questions Carry Equal Marks.

(5×10=50Marks)

UNIT -I

2. a) Explain different Types of Digital data: Unstructured, Semi-structured and Structured.
(Or)
b) Explain Need and Challenges in Big Data Environment?

UNIT -II

3. a) what is Business Intelligence? List different business Intelligence applications with a suitable example?
(or)
b) Explain Classification of Analytics with suitable example.

UNIT -III

4. a) Describe characteristics of a No-SQL database?
(or)
b) Explain the types of No-SQL Data Stores in detail.

UNIT -IV

- 5 a) Explain Hadoop architecture and its components with proper Diagram?
(or)
b) Explain the essentials of Hadoop Ecosystem.?

UNIT -V

6. a) Explain working of the following phases of Map Reduce with one common example
(i) Map Phase (ii) Combiner phase (iii) Shuffle and Sort Phase (iv) Reducer Phase?
(or)
b) Explain HDFS commands.

A.G & S.G Siddhartha Degree College of Arts and Science, Vuyyuru
(An Autonomous College in the jurisdiction of Krishna University)
M.Sc.(Computer Science) Programme - IV Semester

COURSE	COURSE CODE	L	T	P	C	Year
BIG DATA AND ANALYTICS LAB	21MCS402	-	-	6	3	2020-21

Lab List

1. Hadoop standalone installation in Linux.
2. Hadoop installation on windows environment- VM virtual box.
3. Exploring Hadoop Distributed File System (HDFS).
4. Map Reduce Program - Word Count (Python).
5. Write a Map Reduce Program that mines weather data. (Python).
6. Installation of Apache Pig.
7. Pig-Basic Operations: LOAD, FOREACH, GENERATE, GROUP, JOIN, DUMP / STORE.
8. Run Hive then use Hive to create, alter, and drop databases, tables, views, functions, and indexes.
9. Installation of Mongo DB.
10. CRUD (Create, Read, Update and Delete) operations in Mongo DB.
11. Implementation of Aggregate and Map Reduce function in Mongo DB.

A.G & S.G Siddhartha Degree College of Arts & Science, Vuyyuru – 521165.

(An Autonomous College in the jurisdiction of Krishna University)

M.Sc., (Computer Science) Programme - IV Semester

Course	ARTIFICIAL INTELLIGENCE WITH MACHINE LEARNING		
Course Code	21MCS403	Course Delivery Method	Class Room / Blended Mode
Credits	4	CIA Marks	30
No. of Lecture Hours / Week	4	Semester End Exam Marks	70
Total Number of Lecture Hours	60	Total Marks	100
Year of Introduction:2021-22	Year of Offering:2021-22	Year of Revision:2021-22	Percentage of Revision: 0%

Course Outcomes:

1. Identify problems that are amenable to AI techniques and analyse search techniques to solve those problems.
2. Awareness of representation languages like first order logic.
3. Formalize and implement different AI algorithms, various Knowledge Representations and identify the importance of planning to solve AI problems.
4. Understands about basics of machine learning and conceptual learning.
5. To acquire knowledge about ANN and Instance based learning.

Unit	Learning Units	Lecture Hours
I	Introduction: What Is AI? The Foundations of Artificial Intelligence, The History of Artificial Intelligence. Solving Problems by Searching: Problem Solving Agents, Example Problems, Searching for Solutions, Uninformed Search Strategies, Informed (Heuristic) Search Strategies, Heuristic Functions.	12
II	First Order Logic: Representation Revisited, Syntax and Semantics of First Order Logic, Using First Order Logic, Knowledge Engineering in First Order Logic. Inference in First Order Logic: Propositional versus First Order Inference, Unification and Lifting, Forward Chaining, Backward Chaining, Resolution.	10

III	<p>Classical Planning: Definition of Classical Planning ,Algorithms for Planning as State Space Search, Planning Graphs, Other Classical Planning Approaches, Analysis of Planning Approaches.</p> <p>Knowledge Representation: Ontological Engineering, Categories and Objects Events, Mental Eventsand Mental Objects.</p>	14
IV	<p>Learning from Examples: Forms of Learning, Supervised Learning ,Learning Decision Trees, Evaluating and Choosing the Best Hypothesis, The Theory of Learning, Regression and Classificationwith Linear Models.</p> <p>Reinforcement Learning: Introduction, Passive Reinforcement Learning, Active Reinforcement Learning, Generalization in Reinforcement Learning, Policy Search, Applications of Reinforcement Learning.</p>	10
V	<p>Artificial Neural Networks: Neural Network Representation, Appropriate Problems for Neural Network Learning, Perceptrons, Multilayer Networks and the Back Propagation Algorithm, Remarks on the Back Propagation Algorithm, Recurrent Networks, Dynamically Modifying Network Structure.</p> <p>Instance Based Learning: Introduction, K-Nearest Neighbour Learning, Locally WeightedRegression, Radial Basis Functions, Case Based Reasoning.</p>	14

Prescribed Text Book

	Author	Title	Publisher
1	Stuart J. Russell andPeter Norvig	Artificial IntelligenceA Modern Approach	Prentice Hall, Third edition,2010 1.1,1.2,1.3,3.1,3.2,3.3,3.4,3.5,3.6,8.1,8.2,8.3, 8.4,9.1,9.2,9.3,9.4,9.5, 10.1,10.2,10.3,10.4,10.5,12.1,12.2, 12.3,12.4,18.1,18.2,18.3,18.4,18.5, 18.6,21.1, 21.2, 21.3, 21.4, 21.5, 21.6
2	Tom.M. Mitchell	Machine Learning	TMH(2013)4.2,4.3,4.4,4.5,4.6,4.8.3 ,4.8.4,8.1,8.2,8.3,8.4,8.5

Reference Text Books

	Author	Title	Publisher
1	Winston. P.H	Artificial Intelligence	Addison Wesley (1993)
2	Peter Flach	Machine Learning The Art and Science ofAlgorithms that Make Sense of Data	Cambridge University Press
3	Elaine Rich& Kevin Knight	Artificial Intelligence	TMH (1991)

A.G & S.G Siddhartha Degree College of Arts & Science, Vuyyuru – 521165.
(An Autonomous College in the jurisdiction of Krishna University)
M.Sc., (Computer Science) Programme – IV Semester

Course Code: 21MCS403

Title: ARTIFICIAL INTELLIGENCE WITH MACHINE LEARNING

Time: 3Hours

Max.Marks:70

SECTION-A

1. Answer ALL questions

(10x2 = 20 Marks)

- a) Define Artificial Intelligence (AI).
- b) Define Rational Agent
- c) Define Back Propagation
- d) Define Vector Machines
- e) What is K-Means Cluster?
- f) Define Kernal Methods.
- g) What is Polynomial regression?
- h) Define Kernal Estimator
- i) What is Q Learning?
- j) What is Fixed Combination Rules

SECTION-B

Answer Five Questions Choosing One Question from Each Unit.

All Questions Carry Equal Marks.

(5×10=50Marks)

- 2 a) What is AI? Discuss the Heuristic Search Techniques for solving problems.(BTL1)
(or)
b) Discuss Problem Solving Agents with Examples. (BTL6)
- 3 a) Explain the Syntax and Semantics of First Order Logic.(BTL2)
(or)
b) Demonstrate the concept of resolution with an example.(BTL2)
- 4 a) Explain how to design algorithms for Planning as State Space Search. (BTL2)
(or)
b) Discuss On to logical Engineering in Knowledge Representation.(BTL6)
- 5 a) Describe Learning Decision Trees and Evaluating and Choosing Best Hypothesis.(BTL2)
(or)
b) Explain Policy Search and Applications of Reinforcement Learning.(BTL2)
- 6 a) Discuss the Back Propagation Algorithm, Remarks on the Back Propagation Algorithm.(BTL6)
(or)
b) How does K-Nearest Neighbour Learning help in Instance Based Learning and also state the Importance of Radial Basis Functions. (BTL1)

A.G & S.G Siddhartha Degree College of Arts & Science, Vuyyuru – 521165.
(An Autonomous College in the jurisdiction of Krishna University)
M.Sc., (Computer Science) Programme – IV Semester

Course	CLOUD COMPUTING		
Course Code	21MCS404	Course Delivery Method	Class Room / Blended
Credits	4	CIA Marks	30
No. of Lecture Hours / Week	4	Semester End Exam Marks	70
Total Number of Lecture Hours	60	Total Marks	100
Year of Introduction:2021-22	Year of Offering:2021-22	Year of Revision:2021-22	Percentage of Revision: 0%

Course Outcomes:

On successful completion of this course, the students:

6. Understand the Basic Concepts of Operating System, Operating System Structure and Process Concept.(CO1)
7. Applying concepts of Threads, Process Synchronization & CPU Scheduling.(CO2)
8. Understand Deadlock, Main Memory & Virtual Memory.(CO3)
9. Explain Mass Storage Structure, File System Interface & File System Implementation.(CO4)
10. Understanding on I/O Systems, Protection & Security.(CO5)

Unit	Learning Units	Lecture Hours
I	<p>Era of Cloud Computing : Getting to know the cloud - Peer-To-Peer, Client- Server, and Grid Computing – Cloud computing versus Client-server Architecture - Cloud computing versus Peer-To-Peer Architecture - Cloud computing versus Grid Computing - How we got to the Cloud - Server Virtualization versus cloud computing - Components of Cloud computing – Cloud Types – Cloud Computing Service delivery Models.</p> <p>Introducing Virtualization : Introducing Virtualization and its benefits – Implementation levels of Virtualization – Virtualization at the OS Level – Virtualization Structure – Virtualization Mechanisms – Open Source Virtualization Technology – Binary Translation with Full Virtualization – Virtualization of CPU, Memory and I/o Devices – Hardware support for Virtualization in Intel x86 Processor</p>	12
II	<p>Cloud Computing Services: Infrastructure as a Service – Platform as a Service – Language and Pass – Software as a Service – Database as a Service.</p> <p>Open Source Cloud Implementation and Administration: Open-source Eucalyptus Cloud Architecture – Open-source Open stack Cloud Architecture.</p>	10
III	<p>Application Architecture for Cloud: Cloud Application Requirements – Recommendations for Cloud Application Architecture – Fundamental Requirements for Cloud Application Architecture – Relevance and use of Client- server architecture for Cloud Applications – Service oriented Architecture for Cloud Applications.</p> <p>Cloud Programming: Programming support for Google Apps Engine – Big Table as Google’s NOSQL System – Chubby as Google Distributed Lock Service – Programming support for Amazon EC2 – Elastic Block Store (ESB).</p>	14

IV	<p>Risks, Consequences and Costs for Cloud Computing : Introducing Risks in Cloud Computing – Risk Assessment and Management – Risk of Vendor Lock-in – Risk of Loss Control – Risk of Not Meeting Regulatory Compliances – Risk of Resource Scarcity – Risk in Multi Tenant Environment – Risk of Failure – Risk of Failure of Supply Chain – Risk of Malware and Internet attacks – Risk of Inadequate SLA – Risk of Management of Cloud Resources – Risk of Network Outages – Risks in the Physical Infrastructure – Legal Risk due to Legislation – Risks with Software and Application Licensing – Security and Compliance Requirements in a Public Cloud – Direct and Indirect Cloud Costs – Calculating Total cost of Ownership for Cloud Computing – Cost Allocations in a Cloud.</p> <p>AAA administration for clouds : The AAA Model, Single Sign-on for Clouds – Industry Implementations for AAA- Authentication management in the Cloud – Authorization management in the Cloud.</p>	10
V	<p>Application Development for cloud : Developing On-Premise Versus Cloud Applications – Modifying Traditional Applications for Deployment in the Cloud Stages during the development process of Cloud Application - Managing a Cloud Application – Using Agile Software Development for Cloud Applications</p> <p>Cloud Applications: What Not to do - Static code analysis for cloud applications – Developing Synchronous and Asynchronous Cloud Applications.</p> <p>Mobile Cloud Computing : Definition of Mobile Cloud Computing – Architecture of Mobile Cloud Computing – Benefits of Mobile Cloud Computing</p> <p>Mobile Cloud Computing Challenges.</p>	14

Prescribed Text Book			
	Author	Title	Publisher
1	Thomas Erl, Zaigham Mahmood, Ricardo	Cloud Computing - Concepts Technology and Architecture	Pearson
2	Raj Kumar Buyya, Christen vecctiola,S Tammarai selvi	Mastering Cloud Computing, Foundations and Application Programming	TMH

Reference Text Books			
	Author	Title	Publisher
1	Kailash Jayaswal, Jagannath Kallakurchi, Donald J. Houde Dr. Deven Shah	Cloud Computing, Black Book	Dreamtech press

A.G & S.G Siddhartha Degree College of Arts & Science, Vuyyuru – 521165.
(An Autonomous College in the jurisdiction of Krishna University)
M.Sc., (Computer Science) Programme – IV Semester

Course Code: 21MCS404

Title: CLOUD COMPUTING

Time: 3Hours

Max.Marks:70

1. Answer ALL questions

(10x2 = 20 Marks)

- a) Define cloud computing.
- b) What is Grid computing?
- c) Define Virtualization.
- d) Explain Database as a service.
- e) Explain cloud application requirements.
- f) Define Service oriented Architecture.
- g) Explain ESB.
- h) Explain Malware and Internet attacks.
- i) What is a Synchronous cloud application?
- j) Explain the benefits of Mobile cloud computing.

Answer Five Questions Choosing One Question from Each Unit.

All Questions Carry Equal Marks.

(5×10=50Marks)

UNIT -I

2. a) Explain virtualization mechanisms?

(Or)

- b) Write about peer-to-peer network families?

UNIT -II

3. a) Explain cloud computing services?

(or)

- b) Explain open-source Eucalyptus Cloud Architecture?

UNIT -III

4. a) Explain NO-SQL system?

(or)

- b) Explain fundamental requirements for Cloud Application Architecture?

UNIT -IV

5. a) Explain Authentication management in the cloud?

(or)

- b) What is utility computing? Explain utility model for cloud web services?

UNIT -V

6. a) Explain how to manage a Cloud Application?

(or)

- b) Write about Mobile Cloud Computing Challenges?

Criteria for Internal Assessment in Lab Courses

- There should be one internal practical lab examination for 15 marks at the end of each semester and the assessment of internal practical examination is to be done for 5 marks for **Written Procedure**, plus 5 marks for **Program Execution**, plus 5 marks for **Viva-Voce / Online Test** in respective Laboratory Courses(papers).

Written Procedure	Program Execution	Viva Voce/Online Test	Total
A	B	C	D=(A+B+C)
5Marks	5Marks	5Marks	15Marks

- Maximum 15marks are to be awarded for practical laboratory performance basing on the average of best75% marks scored in completed lab exercises from the complete lab list. The schema for awarding these 15marks is given as under:

Schem of Continuous Internal Evaluation of Individual Student for Practical Laboratory Courses							
Course: M.Sc.,(ComputerScience)			Course Code:		Semester:	Title of Laboratory:	Total No of Exercises:
Registration Number:			Name of the Student:				
Exercise Number	Exercise Name	DateofExecution	Record (5Marks)	Execution (10Marks)	Total(15Marks)	Signature of Student	Signature of Faculty

1. Internal Assessment for Seminar Based Courses

- Internal marks for seminar are based on Seminar Report of 25Marks and End Semester ExaminationViva-voce of 25Marks.
- The time duration allotted for each student to deliver the seminaris10-20 minutes.

Seminar Report	End Semester Examination(Viva-voce)	Total
	The Viva Voice shall be conducted by a committee consisting of HOD, faculty in Charge and a senior faculty member of the department.	
A	B	(A+B)
25Marks	25Marks	50Marks

2. ExternalEvaluationof LabCourses

- The external evaluation of *practical examination* shall comprise of 10Marksfor **LabRecord**,25Marksfor **Written Procedure**, 25Marksfor **Program Execution**and10Marksfor**Viva-Voce/ Online Test**.

Evaluation Method for External Practical Examination				
Lab Record	Written Procedure	Program Execution	Viva Voce/ Online Test	Total
A	B	C	D	(A+B+C+D)
10Marks	25	25Marks	10Marks	70Marks

Evaluation Criteria for allocation of the 10Marks to Lab Record in External Practical Examination		
S.No.	Percentage of Lab Exercises completed in the Lab List	Marks to be Awarded
1	Above or Equalto95%	10Marks
2	Above or Equalto90 and below 95%	9Marks
3	Above or Equalto85and below 90%	8Marks
4	Above or Equalto80and below 85%	7Marks
5	Above or Equalto75and below 80%	6Marks
6	Less than 75%	5Marks

5.ProjectWorkEvaluation

- Internal assessment of Project Work will be done by the concerned *Project Internal Guide, Committee consisting of HOD* for 100 marks.

Evaluation Schema for Continuous Internal Assessment of Project Work	
Project midterm Review and Evaluation	50Marks
Project Report/ Thesis /Record.	50Marks
Total	100Marks

- *External evaluation and Viva-voce* of Project Work will be carried out by *Committee Consisting of HOD, Project Supervisor* and an *External Examiner* nominated by the controller of examinations for 100Marks.

Evaluation Schema for External Project Work Assessment	
Project Report/ Thesis /Record	50Marks
End Semester Examination through Viva-voce.	50Marks
Total	100Marks

- Every faculty member must guide a minimum of five students in *Project Work* off the designated workload.

**A.G & S.G SIDDHARTHA DEGREE COLLEGE OF ARTS & SCIENCE,
VUYYURU-521165**

(An Autonomous College in the Jurisdiction of Krishna University)Accredited

at the level 'A' by the NAAC

Sponsors: Siddhartha Academy of General& Technical Education



DEPARTMENT OF COMPUTER SCIENCE

Minutes of the meeting of Board of Studies in Computer Science for PG (M.Sc.)

Date: 25-11-2021



A.G & S.G SIDDHARTHA DEGREE COLLEGE OF ARTS AND SCIENCE::VUYYURU

(An Autonomous College in the Jurisdiction of Krishna University)
Accredited at the level 'A' by the NAAC
Sponsors: Siddhartha Academy of General & Technical Education

DEPARTMENT OF COMPUTER SCIENCE (PG)

Minutes of the meeting of Board of Studies in Computer Science for M.Sc. (Computer Science) programme
held on 25-11-2021 at 11:00A.M. for the Department of Computer Science.

Members Present		
Name of the Member	Role	Signature
Smt. T.Keerthi, I/C HOD, Dept. of Computer Science, A.G & S.G Siddhartha Degree College of Arts & Science, Vuyyuru-521165. Mobile: 9959558485 E-Mail: keerthitineni16@gmail.com	Chairman	
Dr. K.Madhavi, Associate Professor, Dept of Computer Science, JNTUA. College of Engineering, Anantapur. Mobile: 9440206501 E-Mail: kasamadhavi@yahoo.com	University Nominee, Krishna University	
Dr.R.Satya Prasad, Professor, Department of Computer Science, Acharya Nagarjuna University, Nagarjuna Nagar-522508. Mobile: 9848487478 E-Mail: profrsp@gmail.com	Subject Expert	
Dr.T.S.Ravi Kiran, H.O.D & Assistant Professor, Dept of Computer Science, P.B. Siddhartha Degree College of Arts & Science-Vijayawada -520002. Mobile: 9441176980 E-Mail: kirantsr1@gmail.com	Special Invitee	
Sri.U.Sairam, C.E.O, Codegnan I.T Solutions OPC PVT LTD., Vijayawada 520002 Mobile: 9959555952 E-Mail: uppugundlasairam@gmail.com	Industrialist	
Ms. P.Srujana, Software Developer, TonmetriInfoSolutions, Vijayawada. Mobile: 9032671688 E-Mail: srujanapaladugu26@gmail.com	Alumni Representative	
Smt. V. Munki, Assistant Professor, A.G & S.G Siddhartha Degree College of Arts & Science. Mobile: 8099205522 E-Mail: munki.j2ee@gmail.com	Member	
Sri.B.MadhuSudhana Rao, Assistant Professor, A.G & S.G Siddhartha Degree College of Arts & Science. Mobile: 7842664766 E-Mail: ms.madhu27@gmail.com	Member	

AGENDA

- To discuss and approve the *Structure, Syllabi and Model Question Papers* of *Third Semester* of M.Sc.(Computer Science) for the batch of students admitted from the academic year 2020-2021 and onwards.
- To discuss and approve the *Structure, Syllabi and Model Question Papers* of *First Semester* of M.Sc.(Computer Science) for the batch of students admitted from the academic year 2021-2022 and onwards.

RESOLUTIONS

- **Resolved and recommended to introduce new syllabus, model papers in the Third Semester for the following courses:**
 - Internet of Things (20CS3T1)
 - Cryptography & Network Security (20CS3T2)
 - Design & Analysis Algorithms (20CS3T3)
 - Data Mining techniques (20CS3T4)
 - Web Technologies LAB (20CS3L1)
 - Data Mining Lab (20CS3L2)
- **To discuss and approve the *Structure, Syllabi and Model Question Papers* of Open Electives “*Visual Analytics for Executes*” and “*Web Programming*” for Third Semester**
- **Resolved and recommended to continue the same syllabus, model papers without changes in the First Semester for the following courses:**
 - Problem Solving Using Python programming (21CS1T1)
 - Computer Organization (21CS1T2)
 - Python Lab (21CS1L1)
- **Resolved and recommended to introduce new syllabus, model papers in the First Semester for the following courses:**
 - Software Engineering (21CS1T3)
 - Database Management System (21CS1T4)
 - Theory of Computation (21CS1T5)
 - DBMS Lab (21CS1L2)

A.G & S.G Siddhartha Degree College of Arts & Science, Vuyyuru – 521165.
(An Autonomous College in the jurisdiction of Krishna University)
M.Sc., (Computer Science) Programme - I Semester

COURSE	COURSE CODE	L	T	P	C	Year
PROBLEM SOLVING USING PYTHON PROGRAMMING	20CS1T1	4	-	-	4	2020-21

Course Outcomes:

On successful completion of this course, the students:

1. Understand basics of Python Programming. (CO1)
2. Gain knowledge on *Decision Control Statements* and *Functions & Modules*. (CO2)
3. Be familiar with *Python Strings* and *Data Structures*. (CO3)
4. Have knowledge on *Classes & Objects*. (CO4)
5. Apply *Inheritance, Error and Exception Handling* and *Operator Overloading*. (CO5)

UNIT I

Basics of Python Programming: Features of Python, History of Python, The Future of Python, Writing and Executing First Python Program, Literal Constants, Variables and Identifiers, Data Types, Input Operation, Comments, Reserved Words, Indentation, Operators and Expressions, Expressions in Python, Operations on Strings, Other Data Types, Type Conversion.

UNIT II

Decision Control Statements: Conditional Branching Statements, Basic Loop Structures, Nested Loops, The Break Statement, The Continue Statement, The Pass Statement. The Else Statement used with Loops.

Functions and Modules: Function Definition, Function Call, Variable Scope and Lifetime, The Return Statement, More on Defining Functions, Recursive Functions, Modules, Packages in Python, Standard Library Modules.

UNIT III

Python Strings Revisited: Concatenating, Appending and Multiplying Strings, String Formatting Operator, Built in String Methods and Functions, Comparing Strings, Regular Expressions.

Data Structures: Sequence, Lists, Functional Programming, Tuple, Sets, Dictionaries.

UNIT IV

Classes and Objects: Classes and Objects, Class Method and self Argument, Class Variables and Object Variables, Public and Private Data Members, Private Methods, Calling a Class Method from Another Class Method, Built-in Class Attributes, Class Methods, Static Methods.

UNIT V

Inheritance: Inheriting Classes in Python, Types of Inheritance, Abstract Classes and Interfaces.

Error and Exception Handling: Introduction to Errors and Exceptions, Handling Exceptions, Raising Exceptions, Built-in and User defined Exceptions

Operator Overloading: Concept of Operator Overloading, Advantage of Operator Overloading, Implementing Operator Overloading.

Prescribed Text Book			
	Author	Title	Publisher
1	Reema Thareja	Python Programming Using Problem Solving Approach	Oxford University Press

Reference Text Book			
	Author	Title	Publisher
1	Wesley Chun	Core Python Programming	Prentice Hall

A.G & S.G Siddhartha Degree College of Arts & Science, Vuyyuru – 521165.
(An Autonomous College in the jurisdiction of Krishna University)
M.Sc., (Computer Science) Programme - I Semester
Course Code: 20CS1T1 Title: PROBLEM SOLVING USING PYTHON PROGRAMMING
(w.e.f admitted batch 2020-21)

Time: 3 Hours

Max. Marks: 70

Answer ALL questions

(10×2 = 20 Marks)

1. a) Define *Comments* and *Operators*. (BTL1)
- b) Define *Indentation*. (BTL1)
- c) What is *Dangling else Problem*? (BTL1)
- d) What is a *Package*? (BTL1)
- e) What is a *Slice*? (BTL1)
- f) Define *Immutable*. (BTL1)
- g) What is *Class Variable* and *Instance Variable*? (BTL1)
- h) What is *Namespace*? (BTL1)
- i) Differentiate *Error* and *Exception*? (BTL3)
- j) What is *Membership Operator*. (BTL1)

Answer Five Questions Choosing One Question from Each Unit.
All Questions Carry Equal Marks. (5×10 = 50 Marks)

UNIT – I

2. A) Explain the features of Python Programming Language.(BTL2)
(or)
B) Explain *Different Types of Operators* in Python. (BTL2)

UNIT – II

3. A) Discuss *Basic Loop Structures* in Python with illustrations. (BTL6)
(or)
B) Explain *Modules* in Python with examples. (BTL2)

UNIT – III

4. A) State built-in *String Methods* and *Functions* in Python.(BTL1)
(or)
B) Explain *Tuple Data Structure* in Python with examples. (BTL2)

UNIT – IV

5. A) What are *Classes* and *Objects*? Write a program in Python to illustrate an instance variable. (BTL1)
(or)
B) Explain *Class Method* and *Static Method* with example. (BTL2)

UNIT – V

6. A) Explain *Different Types of Inheritance in Python* with suitable examples. (BTL2)
(or)
B) Explain any three *Built-in Exceptions* with relevant examples. (BTL2)

A.G & S.G Siddhartha Degree College of Arts & Science, Vuyyuru – 521165.
(An Autonomous College in the jurisdiction of Krishna University)
M.Sc., (Computer Science) Programme - I Semester

COURSE	COURSE CODE	L	T	P	C	Year
COMPUTER ORGANIZATION	20CS1T2	4	-	-	4	2020-21

Course Outcomes:

On successful completion of this course, the students:

1. Understand *Digital Logic Circuits, Digital Components and Data Representation*. (CO1)
2. Know *Register Transfer and Micro Operations and Basic Computer Organization and Design*. (CO2)
3. Be familiar with *Micro Programmed Control and Central Processing Unit*. (CO3)
4. Have knowledge on *Computer Arithmetic*. (CO4)
5. Understand *Input-Output Organization & Memory Organization*. (CO5)

UNIT I

Digital Logic Circuits: Digital Computers, Logic Gates, Boolean Algebra, Map Simplification, Combinational Circuits, Flip-Flops, Sequential Circuits.

Digital Components: Integrated Circuits, Decoders, Multiplexers, Registers, Shift Registers, Binary Counters, Memory Unit.

Data Representation: Data Types, Complements, Fixed-Point Representation, Floating-Point Representation, Other Binary Codes, Error Detection Codes.

UNIT II

Register Transfer and Micro Operations: Register Transfer Language, Register Transfer, Bus & Memory Transfers, Arithmetic Micro Operations, Logic Micro Operations, Shift Micro Operations, Arithmetic Logic Shift Unit.

Basic Computer Organization and Design: Instruction Codes, Computer Registers, Computer Instructions, Timing & Control, Instruction Cycle, Memory-Reference Instructions, Input-Output Interrupt.

UNIT III

Micro Programmed Control: Control Memory, Address Sequencing, Micro Program Example, Design of Control Unit.

Central Processing Unit: General Register Organization, Stack Organization, Instruction Formats, Addressing Modes, Data Transfer and Manipulation, Program Control.

UNIT IV

Computer Arithmetic: Introduction, Addition and Subtraction, Multiplication Algorithm, Floating Point Arithmetic Operations, Decimal Arithmetic Unit, Decimal Arithmetic Operations.

UNIT V

Input-Output Organization: Peripheral Devices, Input-Output Interface, Asynchronous Data Transfer, Modes of Transfer, Priority Interrupt.

Memory Organization: Memory Hierarchy, Main Memory, Auxiliary Memory, Associative Memory, Cache Memory.

Prescribed Text Book			
	Author	Title	Publisher
1	M.Morris Mano	Computer System Architecture	3 rd Edition, Pearson Education (2008).

Reference Text Books			
	Author	Title	Publisher
1	V. Rajaraman, T. Radha Krishnan	Computer Organization and Architecture	PHI
2	Behrooz Parhami	Computer Architecture	Oxford (2007)
3	ISRD group	Computer Organization	Ace series, TMH (2007)
4	William Stallings	Computer Organization and Architecture – Designing for Performance	Pearson Education (2005)
5	P.Chakraborty	Computer Architecture and Organization	Jaico Books (2008)

A.G & S.G Siddhartha Degree College of Arts & Science, Vuyyuru – 521165.
(An Autonomous College in the jurisdiction of Krishna University)
M.Sc., (Computer Science) Programme - I Semester

Course Code: 20CS1T2

Title: COMPUTER ORGANIZATION

(w.e.f admitted batch 2020-21)

Time: 3 Hours

Max. Marks: 70

Answer ALL questions

(10×2 = 20 Marks)

1. a) State any two *Logic Gates with Truth Tables*. (BTL1)
- b) Find the *Binary Number* (?)₂ to *Hexadecimal Number* (1C)₁₆ (BTL1)
- c) What is *Register Transfer*? (BTL1)
- d) What is *Accumulator* ? (BTL1)
- e) What is *Address Sequencing* ? (BTL1)
- f) Give details of *Stack Organization*. (BTL1)
- g) What is *BCD Adder* ? (BTL1)
- h) Perform *Binary Multiplication* for the decimal numbers 23 and 19. (BTL1)
- i) What is the difference between *Isolated* and *Memory Mapped I/O*? (BTL1)
- j) What is *Priority Interrupt* ? (BTL1)

Answer Five Questions Choosing One Question from Each Unit.

All Questions Carry Equal Marks.

(5×10 = 50 Marks)

UNIT – I

2. A) What is *Flip flop*? Explain *different types of Flip flops* in detail. (BTL1)
- (OR)
- B) Explain the *Fixed Point Representation* with an example. (BTL2)

UNIT – II

3. A) Explain *Logic Micro Operations* in detail. (BTL2)
- (OR)
- B) What is *Instruction Cycle*? Explain various phases of *Instruction Cycle*. (BTL1)

UNIT – III

4. A) Describe the design of Control Unit. (BTL2)
- (OR)
- B) Explain various *Addressing Modes*. (BTL2)

UNIT – IV

5. A) What is *BCD Added* ? Explain in detail. (BTL1)
- (OR)
- B) Explain *Booth's Multiplication Algorithm* with example. (BTL2)

UNIT – V

6. A) Explain different *Modes of Data Transfers*. (BTL2)
- (OR)
- B) What is *Cache Memory*? Discuss various *Mapping Procedures* of Cache Memory. (BTL1)

A.G & S.G Siddhartha Degree College of Arts & Science, Vuyyuru – 521165.
(An Autonomous College in the jurisdiction of Krishna University)
M.Sc., (Computer Science) Programme - I Semester

COURSE	COURSE CODE	L	T	P	C	Year
SOFTWARE ENGINEERING	20CS1T3	4	-	-	4	2020-21

Course Outcomes:

On successful completion of this course, the students:

1. Understand various *Software Engineering Methods, Practices, Process Models and Agile Development Strategies*. (CO1)
2. Illustrate *Core Principles, Requirements & Modelling Concepts*. (CO2)
3. Identify different *Software Testing Approaches* and various aspects of *Software Quality Assurance*. (CO3)
4. Classify various *Process & Project Management Concepts*. (CO4)
5. Estimate *Software Projects & apply Formal Methods Modelling*. (CO5)

UNIT I

Software and Software Engineering: The Nature of Software: Defining Software, Software Application Domains, Legacy Software, The Unique Nature of WebApps, Software Engineering, The Software Process, Software Engineering Practices: The Essence of Practice, General Principles, Software Myths.

Process Models: A Generic Process Model: Defining a Framework Activity, Identifying a Task Set, Process Patterns, Process Assessment and Improvement, Prescriptive Process Models: The Waterfall Model, Incremental Process Models, Evolutionary Process Models, Concurrent Models, A Final Word on Evolutionary Processes, Specialized Process Models: Component-Based Development, The Formal Methods Model, Aspect-Oriented Software Development, The Unified Process: A Brief History, Phases of the Unified Process, Personal and Team Process Models: Personal Software Process (PSP), Team Software Process (TSP).

Agile Development: What Is Agility, Agility and the Cost of Change, What Is an Agile Process: Agility Principles, The Politics of Agile Development, Human Factors, Extreme Programming (XP): XP Values, The XP Process, Industrial XP, The XP Debate, Other Agile Process Models: Adaptive Software Development (ASD), Scrum, Dynamic Systems Development Method (DSDM), Crystal, Feature Driven Development (FDD), Lean Software Development (LSD), Agile Modeling (AM), Agile Unified Process (AUP).

UNIT II

Principles that Guide Practice: Core Principles: Principles That Guide Process, Principles That Guide Practice, Principles That Guide Each Framework Activity: Communication Principles, Planning Principles, Modeling Principles, Construction Principles, Deployment Principles.

Requirements Modeling: Scenarios, Information, and Analysis Classes: Requirements Analysis: Overall Objectives and Philosophy, Analysis Rules of Thumb, Domain Analysis, Requirements Modeling Approaches, Scenario-Based Modeling: Creating a Preliminary Use Case, Refining a Preliminary Use Case, Writing a Formal Use Case, UML Models That Supplement the Use Case: Developing an Activity Diagram, Swimlane Diagrams.

Data Modeling Concepts: Data Objects, Data Attributes, Relationships, Class-Based Modeling: Identifying Analysis Classes, Specifying Attributes, Defining Operations, Class-Responsibility-Collaborator (CRC) Modeling, Associations and Dependencies, Analysis Packages.

UNIT III

Software Quality Assurance: Background Issues, Elements of Software Quality Assurance, SQA Tasks, Goals, and Metrics: SQA Tasks, Goals, Attributes, and Metrics, Formal Approaches to SQA, Statistical Software Quality Assurance: A Generic Example, Six Sigma for Software Engineering, Software Reliability: Measures of Reliability and Availability, Software Safety, The ISO 9000 Quality Standards, The SQA Plan.

Software Testing Strategies: A Strategic Approach to Software Testing: Verification and Validation, Organizing for Software Testing, Software Testing Strategy-The Big Picture, Criteria for Completion of Testing, Strategic Issues, Test Strategies for Conventional Software: Unit Testing, Integration Testing, Test Strategies for Object-Oriented Software: Unit Testing in the OO Context, Integration Testing in the OO Context, Test Strategies for WebApps, Validation Testing: Validation-Test Criteria, Configuration Review, Alpha and Beta Testing, System Testing: Recovery Testing, Security Testing, Stress Testing, Performance Testing, Deployment Testing, The Art of Debugging: The Debugging Process, Psychological Considerations, Debugging Strategies, Correcting the Error

Testing Conventional Applications: Software Testing Fundamentals, Internal and External Views of Testing, White-Box Testing, Basis Path Testing: Flow Graph Notation, Independent Program Paths, Deriving Test Cases, Graph Matrices, Control Structure Testing: Condition Testing, Data Flow Testing, Loop Testing, Black-Box Testing: Graph-Based Testing Methods, Equivalence Partitioning, Boundary Value Analysis, Orthogonal Array Testing,

UNIT IV

Project Management Concepts: The Management Spectrum: The People, The Product, The Process, The Project, People: The Stakeholders, Team Leaders, The Software Team, Agile Teams, Coordination and Communication Issues, The Product: Software Scope, Problem Decomposition, The Process: Melding the Product and the Process, Process Decomposition, The Project, The W5HH Principles.

Process and Project Metrics: Metrics in the Process and Project Domains: Process Metrics and Software Process Improvement, Project Metrics, Software Measurement: Size-Oriented Metrics, Function-Oriented Metrics, Reconciling LOC and FP Metrics, Object-Oriented Metrics, Use-Case-Oriented Metrics, WebApp Project Metrics, Metrics for Software Quality: Measuring Quality, Defect Removal Efficiency.

UNIT V

Formal Modeling And Verification: The Cleanroom Strategy, Functional Specification: Black-Box Specification, State-Box Specification, Clear-Box Specification, Cleanroom Design: Design Refinement, Design Verification, Cleanroom Testing: Statistical Use Testing, Certification, Formal Methods Concepts, Applying Mathematical Notation for Formal Specification, Formal Specification Languages: Object Constraint Language (OCL), The Z Specification Language.

Estimation for Software Projects: Resources: Human Resources, Reusable Software Resources, Environmental Resources, Software Project Estimation, Decomposition Techniques: Software Sizing, Problem-Based Estimation, An Example of LOC-Based Estimation, An Example of FP-Based Estimation, Empirical Estimation Models: The Structure of Estimation Models, The COCOMO II Model, The Software Equation, Estimation for Object-Oriented Projects.

Prescribed Text Book			
	Author	Title	Publisher
1	Roger S Pressman	Software Engineering - A Practitioner's Approach	Seventh Edition, McGraw - Hill, A Business Unit of The McGraw-Hill Companies, Inc., 2010

Reference books			
	Author	Title	Publisher
1	Sommerville	Software engineering	7 th edition, Pearson education
2	S.A.Kelkar	Software Engineering - A Concise Study	PHI.
3	Waman S.Jawadekar	Software Engineering	TMH.
4	AH Behforooz and Frederick J.Hudson	Software Engineering Fundamentals	Oxford (2008)

A.G & S.G Siddhartha Degree College of Arts & Science, Vuyyuru – 521165.
(An Autonomous College in the jurisdiction of Krishna University)
M.Sc., (Computer Science) Programme - I Semester
Course Code: 20CS1T3 Title: SOFTWARE ENGINEERING
(w.e.f admitted batch 2020-21)

Time: 3 Hours

Max. Marks: 70

Answer ALL questions

(10×2 = 20 Marks)

1. a) Define *Software Engineering*. (BTL1)
- b) What is *PSP & TSP*? (BTL2)
- c) Write any two key features of *Class-Responsibility-Collaborator (CRC) Modeling*. (BTL1)
- d) State any two *Deployment Principles*. (BTL1)
- e) What is *Software Reliability*? (BTL1)
- f) Describe the *Arts of Debugging*. (BTL2)
- g) What are the aspects to be considered while testing *Object Oriented Software*? (BTL1)
- h) Write any two *W5HH Principles*. (BTL1)
- i) State various *Resources* while estimating the *Software Projects*. (BTL1)
- j) What is *State Box*? (BTL1)

Answer Five Questions Choosing One Question from Each Unit.

All Questions Carry Equal Marks.

(5×10 = 50 Marks)

UNIT – I

2. A) What is *Myth*? State various myths of *Software Myths*. (BTL1)
- (or)
- B) Describe any two *Prescriptive Process Models*. (BTL2)

UNIT – II

3. A) State (i) *Communication* and (ii) *Planning Principles*. (BTL1)
- (or)
- B) Describe *Scenario-Based Modeling* in detail. (BTL2)

UNIT – III

4. A) Discuss the testing strategies to test *Conventional Software*. (BTL2)
- (or)
- B) What is *White Box Testing*? Explain in detail. (BTL1)

UNIT – IV

5. A) Discuss the *Management Spectrum* in detail. (BTL6)
- (or)
- B) Explain (i) *Size-Oriented Metrics* and (ii) *Function-Oriented Metrics* in detail. (BTL2)

UNIT – V

6. A) Explain *Functional Specification of Cleanroom Strategy*. (BTL2)
- (or)
- B) Describe (i) *The COCOMO II Model* and (ii) *The Software Equation of Empirical Estimation Models* (BTL2)

A.G & S.G Siddhartha Degree College of Arts & Science, Vuyyuru – 521165.
(An Autonomous College in the jurisdiction of Krishna University)
M.Sc., (Computer Science) Programme - I Semester

COURSE	COURSE CODE	L	T	P	C	Year
DATABASE MANAGEMENT SYSTEMS	20CS1T4	4	-	-	4	2020-21

Course Outcomes:

On successful completion of this course, the students:

1. Understands the *Concepts & Architecture* of Databases. (CO1)
2. Able to apply simple and complex *SQL Queries & Relational Algebra & Relational Calculus* operations. (CO2)
3. Gain knowledge on *ER, EER Schemas & Normalization*. (CO3)
4. Understands *Disk Storage Organization, Hashing & Indexing*. (CO4)
5. Be aware of *Transaction Processing, Concurrency Control and Distributed Databases*. (CO5)

UNIT I

Databases and Database Users: Introduction, An Example, Characteristics of the Database Approach, Actors on the Scene, Workers behind the Scene, Advantage of Using the DBMS Approach.

Database System Concepts and Architecture: Data Models, Schemas, and Instances, Three-Schema Architecture and Data Independence, Database Languages and Interfaces, The Database System Environment, Centralized and Client/Server Architectures for DBMSs.

The Relational Data Model and Relational Database Constraints: Relational Model Concepts, Relational Model Constraints and Relational Database Schemas, Update Operations, Transactions, and Dealing with Constraint Violations.

UNIT II

Basic SQL: SQL Data Definition and Data Types, Specifying Constraints in SQL, Basic Retrieval Queries in SQL, INSERT, DELETE, and UPDATE Statements in SQL.

More SQL: More Complex SQL Retrieval Queries, Views (Virtual Tables) in SQL, Schema Change Statements in SQL.

The Relational Algebra and Relational Calculus: Unary Relational Operations: SELECT and PROJECT, Relational Algebra Operations from Set Theory, Binary Relational Operations: JOIN and DIVISION, Additional Relational Operations, Examples of Queries in Relational Algebra, The Tuple Relational Calculus, The Domain Relational Calculus.

UNIT III

Data Modeling Using the Entity-Relationship (ER) Model: Using High-Level Conceptual Data Models for Database Design, Entity Types, Entity Sets, Attributes, Keys, Relationship Types, Relationship Sets, Roles, Structural Constraints, Weak Entity Types, ER Diagrams, Naming Conventions, Design Issues.

The Enhanced Entity-Relationship (EER) Model: Subclasses, Super classes, Inheritance, Specialization and Generalization, Constraints and Characteristics of Specialization and Generalization Hierarchies, Modeling of UNION Types Using Categories, A Sample UNIVERSITY EER Schema, Design Choices, Formal Definitions.

Functional Dependencies: Introduction, Basic Definitions, Trivial and Non-Trivial Dependencies, Closure of set of Dependencies, Closure of set of Attributes, Irreducible sets of dependencies.

Further Normalization 1NF, 2NF, 3NF, BCNF: Introduction, Nonloss decomposition and functional dependencies, 1st, 2nd and 3rd normal forms, Boyce-Codd Normal Form. Multivalued Dependency and Fourth Normal Form, Join Dependencies and Fifth Normal.

UNIT IV

Disk Storage, Basic File Structures and Hashing: Secondary Storage Devices, Buffering of Blocks, Placing File Records on Disk, Operations on Files, Files of Unordered Records (Heap Files), Files of Ordered Records (Sorted Files), Hashing Techniques, Parallelizing Disk Access Using RAID Technology.

Indexing Structures for Files: Types of Single-Level Ordered Indexes, Multilevel Indexes, Dynamic Multilevel Indexes Using B-Trees and B⁺-Trees.

UNIT V

Introduction to Transaction Processing Concepts and Theory: Introduction to Transaction Processing, Transaction and System Concepts, Desirable Properties of Transactions, Characterizing Schedules Based on Recoverability, Characterizing Schedules Based on Serializability, Transaction Support in SQL.

Concurrency Control Techniques: Two-Phase Locking Techniques for Concurrency Control, Concurrency Control Based on Timestamp Ordering, Multiversion Concurrency Control Techniques, Validation (Optimistic) Concurrency Control Techniques, Granularity of Data Items and Multiple Granularity Locking, Using Locks for Concurrency Control in Indexes.

Distributed Databases: Distributed Database Concepts, Types of Distributed Database Systems, Distributed Database Architectures, Data Fragmentation, Replication and Allocation Techniques for Distributed Database Design.

Prescribed Text Book			
	Author	Title	Publisher
1	Ramez Elmasri, Shamkant B. Navathe	Fundamentals of Database Systems.	Pearson Education, Seventh Edition, 2017
2	C.J. Date, A.Kannan, S.Swamynathan	An Introduction to Database Systems	VII Edition Pearson Education (2006).

Reference Text Books			
	Author	Title	Publisher
1	Peter Rob, Carlos Coronel	Database Systems - Design, Implementation and Management	Eighth Edition, Thomson (2008)
2	Raman A Mata - Toledo, Panline K. Cushman	Database Management Systems	Schaum's Outlines, TMH (2007)
3	Steven Feuerstein	Oracle PL/SQL - Programming	10 th Anniversary Edition, OREILLY (2008)

A.G & S.G Siddhartha Degree College of Arts & Science, Vuyyuru – 521165.
(An Autonomous College in the jurisdiction of Krishna University)
M.Sc., (Computer Science) Programme - I Semester
Course Code: 20CS1T4 Title: DATABASE MANAGEMENT SYSTEMS
(w.e.f admitted batch 2020-21)

Time: 3 Hours

Max. Marks: 70

Answer ALL questions

(10×2 = 20 Marks)

1. a) What is *Data Independence*? (BTL1)
- b) What is *Primary Key*? (BTL1)
- c) Write example for *Update Command*. (BTL1)
- d) What is *Join Condition*? Explain with example. (BTL1)
- e) What is *Weak Entity*? (BTL1)
- f) What is *First Normal Form*. (BTL1)
- g) What is *Heap File*. (BTL1)
- h) Write advantage of using *Multilevel Indexes*? (BTL1)
- i) Write *Properties of Transaction*. (BTL1)
- j) What is *Data Fragmentation*? (BTL1)

Answer Five Questions Choosing One Question from Each Unit.

All Questions Carry Equal Marks.

(5×10 = 50 Marks)

UNIT – I

2. A) What is DBMS? Explain advantage of DBMS. (BTL1)
 (or)
 B) Explain *Three Schema Architecture* of DBMS with neat diagram. (BTL2)

UNIT – II

3. A) What is Constraint? Explain various *Constraints* of the Relational Model. (BTL1)
 (or)
 B) Describe *SELECT & PROJECT* Operations of Relational Algebra. (BTL2)

UNIT – III

4. A) What is *Generalization*? Explain with example. (BTL1)
 (or)
 B) What is *BCNF*? Explain with example. (BTL1)

UNIT – IV

5. A) What is Hashing? Describe *Internal & External Hashing Techniques*.
 (or)
 B) What is B-Tree? Construct B-Tree for the values 10, 20, 30, 40, 50, 60, 70, 80, 90 of order 3.

UNIT – V

6. A) Explain *Concurrency Control Based on Timestamp Ordering*. (BTL2)
 (or)
 B) Explain *Distributed Database Concepts* in detail. (BTL2)

A.G & S.G Siddhartha Degree College of Arts & Science, Vuyyuru – 521165.
(An Autonomous College in the jurisdiction of Krishna University)
M.Sc., (Computer Science) Programme - I Semester

COURSE	COURSE CODE	L	T	P	C	Year
THEORY OF COMPUTATION	20CS1T5	4	-	-	4	2020-21

Course Outcomes:

On successful completion of this course, the students:

1. Understand *Fundamentals of Automata and Finite Automata*. (CO1)
2. Able to apply *Regular Languages*. (CO2)
3. Gain knowledge on *Grammar Formalism and Context Free Grammars*. (CO3)
4. Design *Pushdown Automata*. (CO4)
5. Understand *Turing Machine and Computability Theory*. (CO5)

UNIT I

Fundamentals: Strings, Alphabet, Language, Operations, Finite Automaton Model, Acceptance of Strings and Languages, FA, Transition Diagrams and Language Recognizers.

Finite Automata: Deterministic Finite Automaton, Non Deterministic Finite Automaton (Simple Problems), Differences between NFA and DFA, NFA with ϵ Transitions- *Significance of NFA with Epsilon* , *Acceptance of Language*, Conversions and Equivalence-*Conversion from NFA with ϵ to NFA without ϵ , NFA to DFA Conversion, NFA with ϵ to DFA*, Minimization of FSM, Equivalence between two FSMs, Equivalence of Moore and Mealy Machines.

UNIT II

Regular Languages: Regular Sets, Regular Expressions, Identity Rules for Regular Expression, Conversion of Finite Automata (DFA) to Regular Expressions - *using State Elimination Method and Arden's Theorem*, Conversion of Regular Expression to ϵ -NFA, Pumping Lemma of Regular Languages (Sets) (Proofs Not Required).

UNIT III

Grammar Formalism: Regular Grammars - *Right Linear and Left Linear Grammars*, Inter Conversion-*Conversion of a Regular Grammar for a given Finite Automata, Construct FA from Regular Grammar*, Context Free Grammar, Derivation Trees, Sentential Forms, Right most and Leftmost Derivation of Strings.

Context Free Grammars: Ambiguity in Context Free Grammars. Minimization of Context Free Grammars. Chomsky Normal Form, Greibach Normal Form, Pumping Lemma for Context Free Languages, Enumeration Properties of CFL (Proofs Not Required), Simple Problems.

UNIT IV

Push Down Automata: Definition, Model, Design of PDA, Acceptance by Final State and Acceptance by Empty Stack, Inter Conversion - *Construct PDA Equivalent to a given CFL, Construct CFL Equivalent to a given PDA* (Proofs Not Required).

UNIT V

Turing Machine: Definition, Model, Design of TM, Recursively Enumerable Languages and its Properties and Recursive Languages, Types of Turing Machines: Simple Problems.

Computability Theory: Chomsky Hierarchy of Languages: *Regular Grammars, Unrestricted Grammars, Context Sensitive Languages*, Decidability of Problems: *Properties of Recursive and Recursively Enumerable Languages*, Universal Turing Machine, Undecidability of Posts Correspondence Problem, Definition of NP Complete and NP Hard Problems.

Prescribed Text Book			
	Author	Title	Publisher
1	Hopcroft H.E. and Ullman	Introduction to Automata Theory Languages and Computation	J. D. Pearson Education

Reference Text Books			
	Author	Title	Publisher
1	John C Martin	Introduction to languages and the Theory of Computation	TMH
2	A.A Putumbekar	Formal Languages and Automata Theory	Technical Publications
3	Lewis H.P. & Papadimitriou C.H	Elements of Theory of Computation	Pearson PHI
4	Mishra and Chandrashekar	Theory of Computer Science and Automata Languages and Computation	2 nd edition, PHI.
5	Daniel I.A. Cohen	Introduction to Computer Theory	John Wiley

Course Code: 20CS1T5

Title: THEORY OF COMPUTATION

(w.e.f admitted batch 2020-21)

Time: 3 Hours

Max. Marks: 70

Answer ALL questions

(10×2 = 20 Marks)

1.

a) Define Alphabet. (BTL1)

b) Find ϵ -closure of all states for the given *Transition Diagram*. (BTL1)

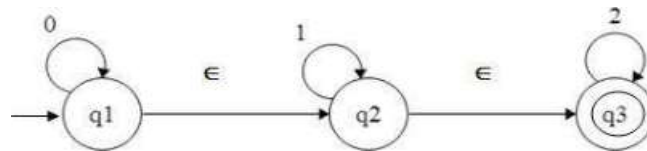

c) Define Set with

Regular Expression and Regular example (BTL1)

d) Write *Regular Expression* which denotes a language L over the set $\Sigma = \{0\}$ having even length of string. (BTL1)

e) Define *Parse Tree* with example. (BTL1)

f) Show that the grammar is ambiguous (BTL2)

$$S \rightarrow a \mid sA \mid \mid bSS \mid \mid SSb \mid \mid SbS \mid$$

g) Give the formal definition of *Push Down Automata*. (BTL1)

h) Define *Deterministic PDA*. (BTL1)

i) What are Recursively Enumerable Languages? (BTL1)

j) Define *Turing Machine*. (BTL1)

Answer Five Questions Choosing One Question from Each Unit.

All Questions Carry Equal Marks.

(5×10 = 50 Marks)

UNIT – I

2. A) Convert the given NFA to DFA. (BTL3)

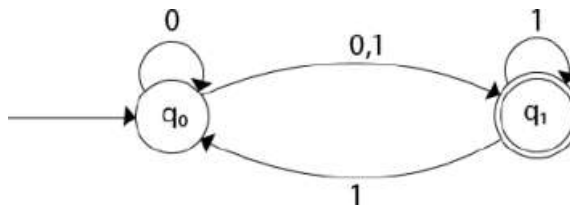

(OR)

B) Construct the minimum DFA for the following *Transition Diagram*. (BTL3)

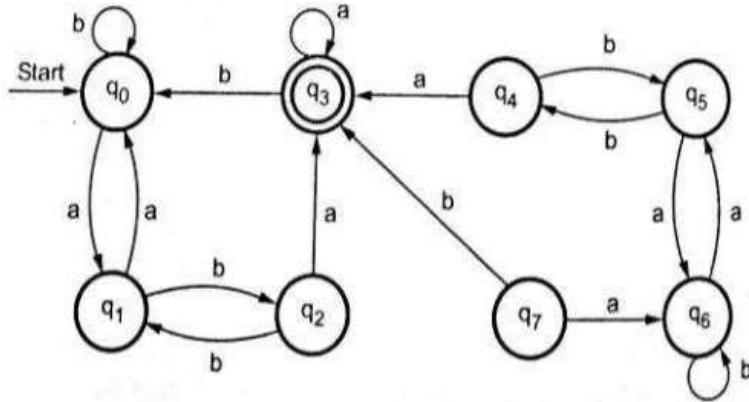

UNIT – II

3. A) Construct epsilon NFA for *Regular Expression* $1+00+010^*$ (BTL3)

(OR)

B) Find *Regular Expression* for the following *DFA* using *State Elimination Method*. (BTL1)

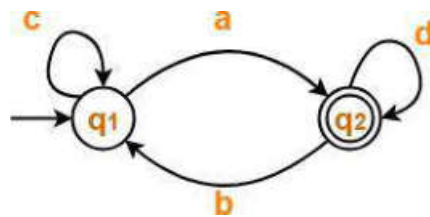

UNIT – III

4. A) Drive the string “aabbabba” for *Leftmost Derivation* and *Rightmost Derivation* using a CFG given by (BTL5)

- $S \rightarrow aB \mid bA$
- $A \rightarrow a \mid aS \mid bAA$
- $B \rightarrow b \mid bS \mid aBB$

(OR)

B) For the following grammar, construct CNF (BTL3)

- $S \rightarrow ABC \mid BbB$
- $A \rightarrow aA \mid BaC \mid aaa$
- $B \rightarrow bBb \mid a \mid D$
- $C \rightarrow CA \mid AC$
- $D \rightarrow \epsilon$

- i) Eliminate ϵ -productions.
- ii) Eliminate any unit productions in the resulting grammar.
- iii) Eliminate any useless symbols in the resulting grammar.

.UNIT – IV

5. A) Convert the following *Context Free Grammar* to *Push Down Automata* (BTL3)

$S \rightarrow AA \mid a$
 $A \rightarrow SA \mid b$

(OR)

- B) The PDA is as given below

$A = (\{q_0, q_1\}, \{0, 1\}, \{S, A\}, \delta, q_0, S, \emptyset)$

Where δ is as given below

$\delta(q_0, 1, S) = \{(q_0, AS)\}$

$\delta(q_0, \epsilon, S) = \{(q_0, \epsilon)\}$

$\delta(q_0, 1, A) = \{(q_0, AA)\}$

$\delta(q_0, 0, A) = \{(q_1, A)\}$

$\delta(q_0, 1, A) = \{(q_1, \epsilon)\}$

$\delta(q_0, 0, S) = \{(q_0, S)\}$

Construct the CFG equivalent to this PDA. (BTL3)

UNIT – V

6. A) Design a *Turing Machine* for the Language $L = \{a^n b^n c^n \mid n \geq 1\}$ (BTL6)

(OR)

- B) Define PCP and also find the correspondence system as given below

$A = (1, 0, 010, 11)$ and $B = (10, 10, 01, 1)$ the input set is $\Sigma = \{0, 1\}$ find the solution. (BTL1)

A.G & S.G Siddhartha Degree College of Arts & Science, Vuyyuru – 521165.
(An Autonomous College in the jurisdiction of Krishna University)
M.Sc., (Computer Science) Programme - I Semester

COURSE	COURSE CODE	L	T	P	C	Year
PROBLEM SOLVING USING PYTHON PROGRAMMING LAB	20CS1L1	-	-	8	4	2020-21

Course Outcomes:

On successful completion of this course, the students:

1. Understand basics of *Python Programming*. (CO1)
2. Gain knowledge on *Decision Control Statements and Functions & Modules*. (CO2)
3. Be familiar with *Python Strings and Data Structures*. (CO3)
4. Apply *Inheritance, Error and Exception Handling and Operator Overloading*. (CO4)
5. Able to connect Database and perform Database Access. (CO5)

1. Write a python program to enter a number and display its hex and octal equivalent and its square root.
2. WAP to read and print values of variables of different data types.
3. WAP
 - a. To calculate area of a triangle using herons formula.
 - b. To calculate the distance between two points.
 - c. To calculate the area of the circle.
4. WAP to perform addition, subtraction, multiplication, division, integer division, and modulo division on two integer numbers.
5. WAP to calculate the total amount of money in the piggybank, given the coins of Rs10, Rs 5, Rs 2 and Rs1.
6. WAP to calculate the bill amount for an item given its quantity sold, value, discount and tax.
7. WAP to calculate a students result based on two examinations, 1 sports event and 3 activities conducted. The weightage of activities=30 percent, sports=20 percent and examination=50 percent.
8. WAP to convert a floating point number into the corresponding integer.
9. A company decides to give bonus to all its employees on diwali. 5% bonus on salary is given to the male workers and 10% bonus on salary to the female workers. WAP to enter the salary of the employee and gender of the employee gets an extra 2% bonus on salary. Calculate the bonus that has to be given to the employee and display the salary that the employee will get.
10. WAP to calculate tax given the following conditions:

If income is less than 1,50,000 then no tax

If taxable income is 1,50,001 – 300,000 then charge 20% tax

If taxable income is above 5,00,001 then charge 30% tax

MIN1 = 150001

MAX1= 300000

RATE1 = 0.10

MIN2 = 300001

MAX2=500000

RATE2=0.20

MIN3=500001

RATE3=0.30

11. WAP to calculate the roots of quadratic equation.
12. WAP to make a simple calculator.
13. WAP to print the calendar of any given year.
14. WAP to calculate simple interest .suppose the customer is a senior citizen. He is being offered 12% interest for all customers the ROI is 10% using functions.
15. WAP to display the date and time using the time module.
16. Write a python program to perform inheritance.
17. Write a Python program to perform exception handling.
18. WAP to demonstrate slice operation on string objects.
19. a. WAP to calculate fib(n) using a dictionary.
b. to create a dictionary cubes of odd numbers in the range 1 to 10.
20. WAP to parse an emailed to print from which email server it was sent and when.
21. WAP to perform operations on stack.
22. WAP to perform read and write operations in files.
23. WAP that accepts filename as an input from an user open a file count a number of times a character appears in the file.
24. Write a program on modules.
25. Write a program to perform image operations.
26. Write a GUI for an expression calculator using tk.
27. Write a program to print text from the audio file. (Speech to Text and using `speech_recognition` library).
28. Write a program to connect database and create a table using SQLite.
29. Write a program to perform insertion and selection operation using SQLite.

A.G & S.G Siddhartha Degree College of Arts & Science, Vuyyuru – 521165.
(An Autonomous College in the jurisdiction of Krishna University)
M.Sc., (Computer Science) Programme - I Semester

COURSE	COURSE CODE	L	T	P	C	Year
DBMS LAB	20CS1L2	-	-	8	4	2020-21

Course Outcomes:

1. Create Database using DDL Commands. (CO1)
2. Retrieve Data from database using DML for a given situation. (CO2)
3. Familiarize with a Query Language through basic SQL Queries. (CO3)
4. Experiment Nested Query, Joins, Integrity Constraints and Views in database. (CO4)
5. Demonstrate Trigger, Function and Procedure using PL/SQL. (CO5)

CYCLE-I

Aim: Marketing Company wishes to computerize their operations by using following tables.

Table Name: Client- Master			
Description: Used to store client information			
Column Name	Data Type	Size	Attribute
CLIENT_NO	Varchar2	6	Primary key and first letter must start with
NAME	Varchar2	20	Not null
ADDRESS 1	Varchar2	30	
ADDRESS S	Varchar2	30	
CITY	Varchar2	15	
PINCODE	Varchar2	8	
STATE	Varchar2	15	
BAL_DUE	Number	10,2	

Table Name: Product_ Master			
Description: Used to store product information			
Column Name	Data Type	Size	Attribute
PRODUCT_NO	Varchar2	6	Primary key and first letter must start with
DESCRIPTION	Varchar2	15	Not null
PROFIT_PERCENT	Number	4,2	Not null
UNIT_MEASUE	Varchar2	10	
QTY_ON_HAND	Number	8	
REORDER_LVL	Number	8	
SELL_PRICE	Number	8, 2	Not null, cannot be 0
COST_PRICE	Number	8,2	Not null, cannot be 0

Table Name: Salesman_Master			
Description: Used to store salesman information working for the company.			
Column Name	Data Type	Size	Attribute
SALESMAN_NO	Varchar2	6	Primary key and first letter must start with „S“
SALESMAN_NAME	Varchar2	20	Not null
ADDRESS1	Varchar2	30	

ADDRESS2	Varchar2	30	
CITY	Varchar2	20	
PINCODE	Number	8	
STATE	Vachar2	20	
SAL_AMT	Number	8,2	Not null, cannot be 0
TGT_TO_GET	Number	6,2	Not null, cannot be 0
YTD_SALES	Number	6,2	Not null
REMARKS	Varchar2	20	

Table Name: Sales_Order			
Description: Used to store client's orders			
Column Name	Data Type	Size	Attribute
ORDER_NO	Varchar2	6	Primary key and first letter must start with „S“
CLIENT_NO	Varchar2	6	Foreign Key
ORDER_DATE	Date		
DELY_ADDRESS	Varchar2	25	
SALESMAN_NO	Varchar2	6	Foreign Key
DELY_TYPE	Char	1	Delivery: part(p)/ full(f) and default „F“
BILL_YN	Char	1	
DELY_DATE	Date		Can't be less than order date
ORDER_STATUS	Varchar2	10	Values (“In Process”, “Fulfilled”,

Table Name: Sales_Order_Details			
Description: Used to store client's order with details of each product ordered.			
Column Name	Data Type	Size	Attribute
ORDER_NO	Varchar2	6	Primary key references SALES_ORDER table
PRODUCT_NO	Varchar2	6	Foreign Key references SALES_ORDER_table
QTY_ORDERED	Number	8	
QTY_DISP	Number	8	
PRODUCT_RATE	Number	10,2	Foreign Key

Solve the following queries by using above tables.

1. Retrieve the list of names, city and the state of all the clients.
2. List all the clients who are located in „Mumbai“ or „Bangalore“.
3. List the various products available from the product_master table.
4. Find the names of sales man who have a salary equal to Rs.3000.
5. List the names of all clients having „a“ as the second letter in their names.
6. List all clients whose Bal due is greater than value 1000.
7. List the clients who stay in a city whose first letter is „M“.
8. List all information from sales-order table for orders placed in the month of July.
9. List the products whose selling price is greater than 1000 and less than or equal to 3000.
10. Find the products whose selling price is greater than 1000 and also find the new selling price as original selling price 0.50.
11. Find the products in the sorted order of their description.
12. Find the products with description as „540HDD“ and „Pen drive“.
13. Count the total number of orders.
14. Print the description and total qty sold for each product.
15. Calculate the average qty sold for each client that has a maximum order value of 15,000.
16. Find all the products whose quantity on hand is less than reorder level.
17. List the order number and day on which clients placed their order.
18. Find out the products and their quantities that will have to deliver in the current month.

19. Find the names of clients who have placed orders worth of 10000 or more.
20. Find the client names who have placed orders before the month of June,2018.

CYCLE-II

Aim: A manufacturing company deals with various parts and various suppliers supply these parts. It consists of three tables to record its entire information. Those are as follows.

Supplier (Supplier_No, Sname, City, status)
 Part(Part_no, pname, color, weight, city, cost)
 Shipment (supplier_No, Part_no, city)
 JX(project_no, project_name, city)
 SPJX (Supplier_no, part_no, project_no, city)

Solve the following queries by using above tables.

1. Get supplier numbers and status for suppliers in Chennai with status > 20.
2. Get project names for projects supplied by supplier S.
3. Get colors of parts supplied by supplier S₁.
4. Get part numbers for parts supplied to any project in Mumbai.
5. Find the id's of suppliers who supply a red or pink parts.
6. Find the pnames of parts supplied by London supplier and by no one else.
7. Get the names of the parts supplied by the supplier „Mart“ and „Miller“.
8. Get supplier names for suppliers who do not supply part P₂.
9. Get all pairs of supplier numbers such that the suppliers concerned are “colocated”.
10. Get suppliers names for the suppliers who supply at least one red part.

CYCLE-III

Aim: An enterprise wishes to maintain a database to automate its operations. Enterprise divided into a certain departments and each department consists of employees. The following two tables describes the automation schemas.

Emp(Empno, Ename, Job, Mgr, Hiredate, Sal, Comm, Deptno)
 Dept(Deptno, Dname, Loc)

Solve the following queries by using above tables.

1. List the details of employees who have joined before the end of September“ 81.
2. List the name of the employee and designation of the employee, who does not report to anybody.
3. List the name, salary and PF amount of all the employees (PF is calculated as 10% of salary)
4. List the names of employees who are more than 2 years old in the organization.
5. Determine the number of employees, who are taking commission.
6. Update the employee salary by 20% , whose experience is greater than 12 years.
7. Determine the department does not contain any employees.
8. Create a view, which contains employee name and their manager names working in sales department.
9. Determine the employees, whose total salary is like the minimum salary of any department.
10. List the department numbers and number of employees in each department.
11. Determine the employees, whose total salary is like the minimum salary of any department.
12. List average salary for all departments employing more than five people.
13. Determine the names of employees, who take highest salary in their departments.
14. Determine the names of employees, who earn more than their managers.
15. Display ename, dname, even if no employee belongs to that department (use outer join).

CYCLE-IV

An Airline system would like to keep track their information by using the following relations.

FLIGHTS(fl_no: integer, from: string, to: string, distance: integer, price: integer)

AIRCRAFT(aid: integer, aname: string, cruising_range: integer)

CERTIFIED(eid: integer, aid: integer)

Employees(eid: integer, ename: string, salary: real)

Note that the employees relation describes pilots and other kinds of employees as well; every pilot is certified for aircraft and only pilots are certified to fly. Resolve the following queries.

- a) Find the names of pilots whose salary is less than the price of the cheapest route from Newyork to Chicago.
- b) For each pilot who is certified for more than 2 aircraft, find the eid's and the maximum cruising range of the aircraft that he or she certified for.
- c) For all aircraft with cruising range over 1,500 miles, find the name of the aircraft and the average salary of all pilots certified for this aircraft.
- d) Find the aid's of all aircraft than can be used from chicaga to LosAngels.
- e) Find the name of the pilots certified from some Boeing aircraft.
- f) Print the enames of pilots who can operate planes with cruising range greater than 3,500 miles, but are not certified by Boeing aircraft.
- g) Find the eid's of employees who are certified for exactly 2 aircrafts.
- h) Find the total amount paid to employees as salaries.
- i) Find the aid's of all than can be used on non-stop flights from Chennai to Dubai.
- j) Find the eid's of employee who make second highest salary.

PL/SQL PROGRAMS

1. Write a PL/SQL program to check the given number is strong or not.
2. Write a PL/SQL program to check the given string is palindrome or not.
3. Write a PL/SQL program to swap two numbers without using third variable.
4. Writ a PL/SQL program to generate multiplication tables for 2, 4, 6.
5. Write a PL/SQL program to check the given number is Amstrong or not.
6. Write a PL/SQL code to find the factorial of any number.
7. Write a PL/SQL program to display sum of even numbers and sum of odd numbers in the given range.
8. Write a PL/SQL program to check the given number is palindrome or not.
9. The HRD manager has decide to raise the employee salary by 15% write a PL/SQL block to accept the employee number and update the salary of that employee. Display appropriate message based on the existence of the record in Emp table.
10. Write a PL/SQL program to display to 10 rows in Emp table based on their job and salary.
11. Write a PL/SQL program to raise the employee salary by 10% for department number 30 people and also maintain the raised details in the raise table.
12. Write a procedure to update the salary of Employee, who are not getting commission by 10%.
13. Write a PL/SQL procedure to prepare an electricity bill by using following table.

Table used: Elect

Name	Null?	Type
MNNO	NOT NULL	NUMBER(3)
CNAME		VARCHAR2(20)
CUR_READ		NUMBER(5)
PREV_READ		NUMBER(5)
NO_UNITS		NUMBER(5)
AMOUNT		NUMBER(8,2)
SER_TAX		NUMBER(8,2)
NET_AMT		NUMBER(9,2)

14. Write a PL/SQL program to prepare an telephone bill by using following table and print the monthly bills for each customer.

Table used: Phone		
Name	Null?	Type
TEL_NO	NOT NULL	NUMBER(6)
CNAME		VARCHAR2(20)
CITY		VARCHAR2(10)
PR_READ		NUMBER(5)
CUR_READ		NUMBER(5)
NET_AMT		NUMBER(5)
TOT-AMT		NUMBER(8,2)

15. Write a PL/SQL program to raise the employee salary by 10 %, who are completed their 25 years of service and store the details at appropriate tables (Define the Retair_ Emp_Table) .
16. Write a PL/SQL program to evaluate the grade of a student with following conditions:
 For pass: all marks > 40
 For I class: Total % > 59
 For II Class: Total % between >40 and < 60
 For III class: total % = 40
 And also maintain the details in abstract table.

1. Table Std		
Name	Null?	Type
NO	NOT NULL	NUMBER
NAME		VARCHAR2(10)
INTNO		NUMBER
CLASS	NOT NULL	VARCHAR2(10)
M1		NUMBER
M2		NUMBER
M3		NUMBER
M4		NUMBER
M5		NUMBER

2. Table Abstract		
Name	Null?	Type
STDNO		NUMBER
STDNAME		VARCHAR2(10)
CLASS		VARCHAR2(10)
MONTH		VARCHAR2(10)
INTNO (INTEGER NUMBER)		NUMBER
TOT		NUMBER
GRADE		VARCHAR2(10)
PERCENT		NUMBER
DAT_ENTER		DATE

Appendix-II
Third Semester Structure, Syllabus & Model Question Papers of M.Sc.(Computer Science)
Programme.
(For the batch of Students admitted during the Academic Year 2020-2021)



A.G & S.G Siddhartha Degree College of Arts & Science
Vuyyuru – 521165
(An Autonomous College in the jurisdiction of Krishna University)
NAAC reaccredited at ‘A’ level

Programme: M.Sc.(Computer Science)

Title of the Paper: Internet of Things

Semester: III

Course Code	20CS3T1	Course Delivery Method	Class Room / Blended Mode
Credits	4	CIA Marks	30
No. of Lecture Hours / Week	4	Semester End Exam Marks	70
Total Number of Lecture Hours	60	Total Marks	100
Year of Introduction :2021-22	Year of Offering:2021-22	Year of Revision:2021-22	Percentage of Revision: 0%

Course Objective: To understand and gain knowledge on *Over View of Internet of Things, Models, Layers & Standardization, Protocols & Design Principles* for Connected Devices, *Internet Connectivity Principles, Protocols & Application Layer Protocols, Data Acquiring, Business Models and Business Processes.*

Course Outcomes: On successful completion of the course student will be able to:

CO1: Attain knowledge over view of *Internet of Things.*

CO2: Understand *Models, Layers & Standardization.*

CO3: Apply *Protocols & Design Principles* for Connected Devices.

CO4: Understand *Internet Connectivity Principles, Protocols & Application Layer Protocols.*

CO5: Understand *Data Acquiring, Business Models and Business Processes.*

Syllabus

Course Details

Unit	Learning Units	Lecture Hours
I	The Internet of Things: An Overview of Internet of Things, Internet of Things Technology, Behind IoT Sources of the IoT, M2M Communication, Examples of IoT, Design Principles for Connected Devices, Business Models for Business Processes in the Internet of Things.	12
II	Design Principles for Connected Devices: IoT / M2M systems layers and Designs Standardizations, Modified OSI Stack for the IoT / M2M Systems, ETSI M2M Domains and High-level Capabilities ,Communication Technologies, Data Enrichment and Consolidation and Device Management Gateway ease of Designing and Affordability.	12
III	Design Principles for the Web Connectivity: Design Principles for the Web Connectivity for Connected Devices, Web Communication Protocols for Connected Devices, Message Communication Protocols for Connected Devices, Web Connectivity for Connected Devices.	12
IV	Internet Connectivity Principles: Introduction, Internet Connectivity, Application Layer Protocols: <i>HTTP, HTTPS, FTP, Telnet.</i>	12
V	Data Acquiring, Organizing and Analytics in IoT / M2M: Introduction, Applications / Services / Business Processes, IOT / M2M Data Acquiring and Storage, Business Models for Business Processes in the Internet of Things, Organizing Data, Transactions, Business Processes, Integration and Enterprise Systems.	12

Prescribed Text Book			
	Author	Title	Publisher
1	Rajkamal	Internet of Things: Architecture, Design Principles and Applications	McGraw Hill Higher Education

Reference Text Book			
	Author	Title	Publisher
1	Adrian McEwen and Hakim Cassimally	Designing the Internet of Things	Wiley
2	CunoPfister	Getting Started with the Internet of Things.	Oreilly

Course Focus: Employability

Websites of Interest:

1. <https://dzone.com/iot-developer-tutorials-tools-news-reviews>
2. <https://www.ibm.com/blogs/internet-of-things/>

A.G & S.G Siddhartha Degree College of Arts & Science, Vuyyuru – 521165.
(An Autonomous College in the jurisdiction of Krishna University)
M.Sc., (Computer Science) Programme - III Semester

Course Code: 20CS3T1

Title: Internet of Things (IoT)

(w.e.f admitted batch 2020-21)

Time: 3 Hours

Max. Marks: 70

Answer ALL questions

(10×2 = 20 Marks)

7. a) What is *M2M Communication*. (BTL1)
- b) What are *Connected Devices*? (BTL1)
- c) Write about *modified ISO*. (BTL1)
- d) What is a *Gateway*? (BTL1)
- e) What is *Communication Protocol*? (BTL1)
- f) What is *Resource and Resource Repository*? (BTL1)
- g) What is *Header*? Explain *TCP Header*. (BTL1)
- h) What is *Protocol Data Unit and Maximum Transferable Unit*. (BTL1)
- i) Write about *Event Data*. (BTL1)
- j) What are *Active and Passive Devices*? (BTL1)

Answer Five Questions Choosing One Question from Each Unit.
All Questions Carry Equal Marks. (5×10 = 50 Marks)

UNIT – I

2. a) Explain an overview of IOT. (BTL2)
- (or)
- b) Explain *implementation of IOT in Smart Cities*. (BTL2)

UNIT – II

3. a) Explain various *Layers & Design Standardization Principles* of IOT. (BTL2)
- (or)
- b) Explain different *communication technologies* used in IOT. (BTL2)

UNIT – III

4. a) What are *Web Communication Protocols* for Connected Devices? (BTL1)
- (or)
- b) What are various *Design Principles* for the Web Connectivity? (BTL1)

UNIT – IV

5. a) Explain in detail *Internet Connectivity Principles*. (BTL5)
- (or)
- b) Explain any two *Application Layer Protocols*. (BTL5)

UNIT – V

6. a) Illustrate *Business Models* for *Business Processes* in the Internet of Things. (BTL2)
- (or)
- b) Explain *Integration* and *Enterprise Systems*. (BTL2)



A.G & S.G Siddhartha Degree College of Arts & Science
Vuyyuru – 521165
(An Autonomous College in the jurisdiction of Krishna University)
NAAC reaccredited at ‘A’ level

Programme: M.Sc.(Computer Science)

Title of the Paper: Cryptography & Network Security

Semester: III

Course Code	20CS3T2	Course Delivery Method	Class Room / Blended Mode
Credits	4	CIA Marks	30
No. of Lecture Hours /	4	Semester End Exam Marks	70
Total Number of Lecture Hours	60	Total Marks	100
Year of Introduction : 2021-22	Year of Offering: 2021-22	Year of Revision: 2021-22	Percentage of Revision: 10

Course Objective: To understand and gain knowledge on *Computer & Network Security, Number Theory, Classical Encryption Techniques, Advanced Encryption Standard and Random Bit Generation and Stream Ciphers, Number Theory, Public Key Cryptography and RSA, Other Public-Key Crypto Systems and Message Authentication Codes, Digital Signatures, Key Management and Distribution and User Authentication, Transport Level Security, Electronic Mail Security and IP Security and Intruders and Firewalls.*

Course Outcomes: On successful completion of this course, the students will be able to:

CO1 : Understand *Computer & Network Security Concepts, Classical Encryption Techniques and Advanced Encryption Standard.*

CO2 : Gain knowledge on *Number Theory, Public Key Cryptography and RSA, Other Public-Key Crypto Systems and Message Authentication Codes.*

CO3 : Know *Digital Signatures, Key Management and Distribution and User Authentication.*

CO4 : Understand *Transport Level Security, Electronic Mail Security and IP Security.*

CO5 : Gain knowledge about *Intruders and Firewalls.*

Syllabus

Course Details

Unit	Learning Units	Lecture Hours
I	<p>Computer & Network Security Concepts: Computer Security Concepts, The OSI Security Architecture, Security Attacks, Security Services, Security Mechanisms, A Model for Network Security.</p> <p>Classical Encryption Techniques: Symmetric Cipher Model, Substitution Techniques, Transposition Techniques</p> <p>Advanced Encryption Standard: AES Structure, An AES Example, AES Implementation. Random Bit Generation and Stream Ciphers: Principles of Pseudo Random Number Generation, Pseudo Random Number Generators.</p>	12
II	<p>Introduction to Number Theory: Divisibility and the Division Algorithm, The Euclidean Algorithm, Modular Arithmetic, Prime Numbers, Fermat's and Euler's Theorems, Testing for Primality, The Chinese Remainder Theorem, Discrete Logarithms.</p> <p>Public Key Cryptography and RSA: Principles of Public Key Crypto Systems, The RSA Algorithm.</p> <p>Other Public-Key Crypto Systems: Key Management, Diffie-Hellman Key Exchange, Elliptic Curve Arithmetic, Elliptic Curve Cryptography.</p> <p>Message Authentication Codes: Message Authentication Requirements, Message Authentication Functions, Requirements for Message Authentication Codes, Security of MACs, MACs Based on Hash Functions: HMAC.</p>	12
III	<p>Digital Signatures: Digital Signatures, NIST Digital Signature Algorithm.</p> <p>Key Management and Distribution: Symmetric Key Distribution Using Asymmetric Encryption, Distribution of Public Keys.</p> <p>User Authentication: Kerberos, Remote User-Authentication Using Asymmetric Encryption.</p>	12
IV	<p>Transport Level Security: Transport Layer Security.</p> <p>Electronic Mail Security: S/MIME, Pretty Good Privacy.</p> <p>IP Security: IP Security Overview, IP Security Policy, Encapsulating Security Payload, Combining Security Associations.</p>	12
V	<p>Intruders: Intruders, Intrusion Detection, Password Management.</p> <p>Firewalls: The Need for Firewalls, Firewall Characteristics and Access Policy, Types of Firewalls.</p>	12

Prescribed Text Book			
	Author	Title	Publisher
1	William Stallings	Cryptography and Network Security	Pearson, Seventh Edition, 2017

Reference Text Book			
	Author	Title	Publisher
1	William Stallings	Cryptography and Network Security	Pearson, Sixth Edition, 2014
2	William Stallings	Network Security Essentials- Applications and Standards	Pearson Education (2007), Third Edition.
3	Chris McNab	Network Security Assessment	OReilly (2007), 2 nd Edition
4	Jon Erickson	Hacking-The Art of Exploitation	Press (2006), SPD
5	Neal Krawety	Introduction to Network Security	Thomson (2007).
6	Ankit Fadia	Network Security-AHackers Perspective	Macmillan (2008)
7	Behrouz A Forouzan, Debdeep Mukhopadhyay	Cryptography and Network Security	MCGraw-Hill, Indian Special Edition, Third Edition, 2015

Course has focus on : Employability

Websites of Interest :

1. https://www.pearsonhighered.com/assets/hip/us/hip_us_pearsonhighered/preface/0132775069.pdf
2. <http://faculty.mu.edu.sa/public/uploads/1360993259.0858Cryptography%20and%20Network%20Security%20Principles%20and%20Practice,%205th%20Edition.pd>

Co-curricular Activities : Programming Contests, Hackathons & Quiz.

A.G & S.G Siddhartha Degree College of Arts & Science, Vuyyuru – 521165.
(An Autonomous College in the jurisdiction of Krishna University)
M.Sc., (Computer Science) Programme - III Semester
Course Code: 20CS3T2 Title: CRYPTOGRAPHY & NETWORK SECURITY
(w.e.f admitted batch 2020-21)

Time: 3 Hours

Max. Marks: 70

Answer ALL questions

(10×2 = 20 Marks)

- 1) a) What is *Caesar Cipher*? (BTL1)
- b) Write any two characteristics of Randomness. (BTL1)
- c) What is the Purpose of the *Euclidean Algorithm*? (BTL1)
- d) What is Message Encryption? (BTL1)
- e) What is the difference between *Symmetric Key Distribution & Asymmetric Key Distribution*? (BTL1)
- f) What is *Mutual Authentication*? (BTL1)
- g) State any two Protocols of *Transport Layer Security*. (BTL1)
- h) What is *Pretty Good Privacy*? (BTL1)
- i) What is *Firewall*? (BTL1)
- j) State any two *Intrusion Detection Techniques*. (BTL1)

Answer Five Questions Choosing One Question from Each Unit.
All Questions Carry Equal Marks. (5×10 = 50 Marks)

UNIT- I

- 2) a) Explain various *Security Attacks* and *Security Services*. (BTL2) 10 Marks
(or)
- b) Explain *AES Encryption* and *Decryption Process*. (BTL2) 10 Marks

UNIT- II

- 3) a) Illustrate *Diffie-Hellman Key Exchange*. (BTL2) 10 Marks
(or)
- b) Explain *Internal and External Error Control* in Message Authentication Functions. (BTL2)
10 Marks

UNIT-III

- 4) a) Explain *NIST Digital Signature Algorithm* with diagram. (BTL5) 10 Marks
(or)
- b) Explain *Kerberos* in detail. (BTL5) 10 Marks

UNIT-IV

- 5) a) Explain *Confidentiality* and *Authentication* in S/MIME. (BTL5) 10 Marks
(or)
- b) Illustrate *Overview of IP Security*. (BTL5) 10 Marks

UNIT-V

- 6) a) Discuss what are the problems that may intruder create and explain how to overcome those problem?
(BTL6) 10 Marks
(or)
- b) Discuss *Various Types of Firewalls*. (BTL6) 10 Marks



A.G & S.G Siddhartha Degree College of Arts & Science
Vuyyuru – 521165
(An Autonomous College in the jurisdiction of Krishna University)
NAAC reaccruited at ‘A’ level

Programme: M.Sc.(Computer Science)

Title of the Paper: Design & Analysis of Algorithms

Semester: III

Course Code	20CS3T3	Course Delivery Method	Class Room / Blended Mode
Credits	4	CIA Marks	30
No. of Lecture Hours / Week	4	Semester End Exam Marks	70
Total Number of Lecture Hours	60	Total Marks	100
Year of Introduction : 2021-22	Year of Offering: 2021-22	Year of Revision: 2021-22	Percentage of Revision:Nil

Course Objective: The objective of this course is to develop proficiency in *Problem Solving and Programming*, To *Perform Analysis of various Algorithms in regard to Time and Space Complexity*, Gain good understanding of *Applications of Data Structures*, To develop a base for *Advanced Study in Computer Science*, To apply *Design Techniques* to solve different types of problems as per their *Complexity* and Develop *ability to segregate NP-Hard and NP-Complete problems*.

Course Outcomes: On successful completion of this course, the students will be able to:

CO1 : Understand *Basic Ideas* about *Analysis of Algorithms and the Concept of Data Structures*.

CO2 : Know *Divide and Conquer ,Greedy Methods* and *Solving Various Problems* by applying them.

CO3 : Apply *Dynamic Programming Method* and *Basic Traversal and Search Techniques* to solve various Problems.

CO4 : Understand *Backtracking* and *Branch and Bound* Techniques to Design Algorithms.

CO5 : Categorize *NP-Hard* and *NP-Complete* Problems.

Syllabus

Course Details

Unit	Learning Units	Lecture Hours
I	<p>Introduction: What is Algorithm, Algorithm Specification Pseudo code Conventions, Recursive Algorithms, Performance Analysis: Space Complexity Time Complexity, Asymptotic Notation, Performance Measurement, Randomized Algorithms: Basics of Probability Theory, Randomized Algorithms Identifying the Repeated Element, Primality Testing: Advantages and Disadvantages.</p> <p>Elementary Data Structures: Stacks and Queues, Trees: Terminology, Binary Trees, Dictionaries: Binary Search Trees, Priority Queues, Heaps , Heapsort , Sets and Disjoint Set Union: Introduction-Union and Find Operations, Graphs: Introduction, Definitions, Graph Representations.</p>	10
II	<p>Divide-and-Conquer: General Method, Defective Chess Board, Binary Search, Finding Maximum and Minimum, Merge Sort, Quick Sort, Selection Problem, Strassen's Matrix Multiplication, Convex Hull: Some Geometric Primitives, The Quick Hull Algorithm, Graham's Scan, An $O(n \log n)$ Divide and Conquer Algorithm.</p> <p>The Greedy Method: The General Method, Container Loading, Knapsack Problem, Tree Vertex Splitting, Job Sequencing with Deadlines, Minimum Cost Spanning Trees: Prim's Algorithm, Kruskal's Algorithm, Optimal Storage on Tapes, Optimal Merge Patterns, Single Source Shortest Paths.</p>	14
III	<p>Dynamic Programming: The General Method, Multi Stage Graphs, All Pairs Shortest Paths, Single Source Shortest Paths, Optimal Binary Search Trees, String Editing -0/1 Knapsack, Reliability Design, The Traveling Sales Person Problem, Flow Shop Scheduling.</p> <p>Basic Traversal and Search Techniques: Techniques for Binary Trees, Techniques for Graphs: Breadth First Search and Traversal-Depth First Search, Connected Components and Spanning Trees, Bi-Connected Components and DFS.</p>	17
IV	<p>Backtracking: The General Method, The 8-Queens Problem, Sum of Subsets, Graph Coloring, Hamiltonian Cycles, Knapsack Problem.</p> <p>Branch and Bound : The Method: Least Cost Search, The 15 Puzzle Control Abstractions for LC Search, Bounding, FIFO Branch and Bound , LC Branch and Bound, 0/1 Knapsack Problem, LC Branch and Bound Solution, FIFO Branch and Bound Solution, Traveling Sales person.</p>	11
V	<p>NP-Hard and NP-Complete Problems: Basic Concepts: Non Deterministic Algorithms, The Classes NP Hard and NP Complex, Cook's Theorem, NP Hard Graph Problems, Clique Decision Problem, Node Cover Decision Problem Chromatic Number Decision Problem, Directed Hamiltonian Cycle, Traveling Sales Person Decision Problem, AND/OR Graph Decision Problem, NP-Hard Scheduling Problems, Scheduling Identical Processors, Flow Shop Scheduling, Job Scheduling, NP-Hard Code Generation Problems, Code Generation With Common Sub Expressions, Implementing Parallel Assignment Instructions, Some Simplified NP-Hard Problems.</p>	8

Prescribed Text Book

S.No	Author	Title	Publisher
1	Sartaj Sahni	Fundamentals of Computer Algorithms	Second Edition, Universities Press (2008)

Reference Text Books			
S.No.	Author	Title	Publisher
1	Anany Levitin	Introduction to the Design & Analysis of	Second Edition, Pearson
2	I.Chandra Mohan	Design and Analysis of Algorithms	PHI
3	Prabhakar Gupta, Vineet Agrawal	Design and Analysis of Algorithms	PHI
4	Parag Himanshu, Dave	Design and Analysis of Algorithms	Pearson Education (2008)

Course Focus: Foundation / Skill Development.

Reference Websites :

1. <https://epgp.inflibnet.ac.in/Home>
2. <https://ocw.mit.edu/courses/electrical-engineering-and-computer-science/6-046j-design-and-analysis-of-algorithms-spring-2015/lecture-notes/>
3. https://www.cukashmir.ac.in/cukashmir/User_Files/imagefile/DIT/StudyMaterial/DAA/DAA_UNIT-I_6th-Sem_StudyMaterial.pdf



A.G & S.G Siddhartha Degree College of Arts & Science
Vuyyuru – 521165
(An Autonomous College in the jurisdiction of Krishna University)
NAAC reaccredited at ‘A’ level

Programme: M.Sc. (Computer Science)
Title of the Paper: Data Mining Techniques
Semester: III

Course Code	20CS3T4	Course Delivery Method	Class Room / Blended Mode
Credits	4	CIA Marks	30
No. of Lecture Hours / Week	4	Semester End Exam Marks	70
Total Number of Lecture Hours	60	Total Marks	100
Year of Introduction : 2021-22	Year of Offering: 2021- 22	Year of Revision: 2021-22	Percentage of Revision: Nil

Course Objective:

To understand and gain knowledge on *Basic Concepts, Applications, Techniques of Data Mining, Data Warehouse Architecture and its Components, Schemas, Different OLAP Operations, Characterize The Kinds of Patterns that can be discovered by Association Rule Mining, Data Classification and Prediction Techniques, Identify the Similarities among the data Using Clustering Algorithms and Outlier Analysis.*

Course Outcomes: On successful completion of this course, the students will be able to

CO1: Understand the *Basics of Data Mining and Data Pre-Processing Techniques.*

CO2: Aware of constructing the *Data Warehouse, OLAP and relevant Data Model Concepts.*

CO3: Understand the *Frequent Itemset Mining Methods* and Different Levels in Association Rules.

CO4: Understand the *Basic Concepts in Classification and Advanced Classification Methods* by implementing *Various Algorithms.*

CO5: Find the similarities among the data using *Clustering Algorithms and Outlier Analysis.*

Syllabus

Course Details

Unit	Learning Units	Lecture Hours
I	<p>Introduction: What is Data mining?, What Kind of Data can be Mined, What kinds of Patterns can be Mined, Major Issues in Data Mining.</p> <p>Data Preprocessing: Data Preprocessing : An Overview, Data Cleaning, Data Integration, Data Reduction-Overview of Data Reduction Strategies, Attribute Subset Selection, Regression and Log Linear Models, Histograms and Clustering, Data Transformation : Data Transformation Strategies Overview, Data Transformation by Normalisation, Discretization by Binning.</p>	12
II	<p>Data Warehousing and OLAP: Data Warehouse : Basic Concepts, What Is a Data Warehouse?, Difference between Operational Database Systems and Data Warehouses, Why have a separate Data Warehouse?, Data Warehousing : A Multiered Architecture, Data Warehouse Models, Extraction, Transformation and Loading, Metadata Repository, Data Warehouse Modeling : Data Cube and OLAP-A Multidimensional Data Mode-From Tables and Spreadsheets to Data Cubes, Stars, Snowflakes and Fact Constellations : Schemas for Multidimensional Data Models , Dimensions : The Role of Concept Hierarchies, Measures: their categorisation and computation, Typical OLAP Operations in the Multidimensional Data Model, A Starnet Query Model for Querying Multidimensional Databases.</p>	12
III	<p>Mining Frequent Patterns, Associations: Basic Concept, Market Basket Analysis : A Motivational Example, Frequent Item Sets, Closed Item Sets and Association Rules, Frequent Item Set Mining Methods.</p> <p>Advanced Pattern Mining: Pattern Mining : A Road Map, Pattern Mining in Multilevel, Multidimensional Space, Mining Multilevel Association Rules, Mining Multi Dimensional Associations, Mining Quantitative Association Rules.</p>	12
IV	<p>Classification: Basic Concepts: What is Classification?, General Approaches to Classification, Decision Tree Induction, Attribute Selection Measures, Tree Pruning, Scalability and Decision Tree Induction, Bayes Classification Methods, Bayes Theorem, Navie Bayesian Classification.</p> <p>Classification: Advanced Methods: Bayesian Belief Networks, Concepts and Mechanisms, Training Bayesian Belief Networks, Classification by Back Propagation.</p>	12
V	<p>Cluster Analysis Introduction: What is Cluster Analysis?, Requirements for Cluster Analysis, A Partitioning Methods : K-Means, K-Medoid, Hierarchical Methods : Agglomerative versus Divisive Hierarchical Clustering, Distance Measures in Algorithmic Methods, BRICH : Multiphase Hierarchical Clustering using Clustering Feature Trees, Chameleon Hierarchical Clustering, Density Based Methods : DBSCAN.</p> <p>Outlier Detection: What is Outliers Analysis?, Types of Outliers, Challenges of Outlier Detection.</p>	12

Text Books			
	Author	Title	Publisher
1	Jiawei Han, Micheline Kamber	Data mining : Concepts & Techniques	Morgan Kaufmann 3 rd Edition Chapter-1 1.2,1.3,1.4,1.7 Chapter-3 3.1,3.2,3.3,3.4(3.4.1,3.4.4,3.4.5,3.4.6,3.4.7) Chapter-4 4.1 to 4.2 Chapter-6 6.1 to 6.2 Chapter-7 7.1,7.2(7.2.1 to7.2.3) Chapter-8 8.1,8.2(8.2.1,8.2.2,8.2.3,8.2.4),8.3 Chapter-9 9.1 to 9.2 Chapter-10 10.1,10.2,10.3(10.3.1,10.3.2,10.3.3,10.3.4),10.4(10.4.1) Chapter-12 12.1(12.1.1,12.1.2,12.1.3)

Reference Books			
	Author	Title	Publisher
1	Ralph Kimball	The Data Warehousing Toolkit	Wiley
2	S.N.Sivanandam, S.Sumathi	Data Mining-Concepts, Tasks and Techniques	Thomson

Websites of Interest:

1. [www- db.stanford.edu / ullman/mining/mining.html](http://www-db.stanford.edu/~ullman/mining/mining.html) : Data mining lecture notes.
2. ocw.mit.edu/ocwweb/slon-School-of-management/15-062Data-Mining Spring2003/course

Course Focus: Foundation / Employability / Skill Development.

A.G & S.G Siddhartha Degree College of Arts & Science, Vuyyuru – 521165.
(An Autonomous College in the jurisdiction of Krishna University)
M.Sc., (Computer Science) Programme - III Semester
Course Code: 20CS3T4 Title: DATA MINING TECHNIQUES
(w.e.f admitted batch 2020-21)

Time: 3 Hours
Answer ALL questions

Max. Marks: 70
(10×2 = 20 Marks)

1. a) Difference between *Data Mining* and *KDD* (BTL4)
- b) What is meant by *Data Preprocessing*? (BTL1)
- c) Define *Multidimensional Data model*. (BTL1)
- d) OLAP versus OLTP (BTL4)
- e) Give one example for *Closed Itemset* and *Maximal Frequent Itemset* (BTL1)
- f) What is meant by *Association Rule*? (BTL1)
- g) Explain *Bayes Theorem*. (BTL2)
- h) Define *Classification* with Example. (BTL1)
- i) What are the requirements of *Cluster Analysis*? (BTL1)
- j) What is meant by *Outliers*? (BTL1)

Answer Five Questions Choosing One Question from Each Unit.

All Questions Carry Equal Marks.

(5×10 = 50 Marks)

UNIT – I

2. A) Define Data Mining. What kinds of Patterns can be mined in *Data Mining*. 10M (BTL1)
(or)
- B) Define *Data Integration*. What are the *Different Techniques used in Data Integration*. 10M (BTL1)

UNIT – II

3. A) Define *Data Warehouse*. Explain *Data Warehouse Architecture* with neat Diagram. 10M (BTL1)
(or)
- B) What are the different types of *Schemas* used in *Multi Dimensional Data Model*? 10M (BTL1)

UNIT – III

4. A) Explain *Aprior Algorithm* with Example. 10M (BTL2)
(or)
- B) Explain *Multi Level and Multi Dimensional Association Rules* with Examples. 10M (BTL2)

UNIT – IV

5. A) Explain *Decision Tree Induction Algorithm* with Example. 10M (BTL5)
(or)
- B) Explain *Naïve Bayes Classification* with Example. 10M (BTL5)

UNIT – V

6. A) Explain *Different Partitioning Methods* used in *Cluster Analysis*. 10M (BTL2)
(or)
- B) Explain in detail about *Hierarchical Clustering*. 10M (BTL2)



A.G & S.G Siddhartha Degree College of Arts & Science
Vuyyuru – 521165
(An Autonomous College in the jurisdiction of Krishna University)
NAAC reaccredited at ‘A’ level

Programme: M.Sc.(Computer Science)

Title of the Paper: Web Technologies Lab

Semester: III

Course Code	20CS3L1	Course Delivery Method	Class Room / Blended Mode
Credits	4	CIA Marks	30
No. of Lecture Hours / Week	8	Semester End Exam Marks	70
Total Number of Lecture Hours	90	Total Marks	100
Year of Introduction : 2021-22	Year of Offering: 2021- 22	Year of Revision: 2021-22	Percentage of Revision: 0%

Course Objective: Able to build functional *Web Applications using HTML*, Able to use *JavaScript and DHTML* for *Web Designing*, Able to code using *XML and PHP* for *Integrating with Web Pages*, Create *Dynamic Web Pages* where in client interaction is facilitated using advanced server technology like *JSP* and *Web Pages with Database Connectivity using PHP*.

Course Outcomes: On successful completion of the course student will be able to:

CO1: Build functional *Web Applications HTML*.

CO2: Incorporates *Multimedia Capabilities* and *Web Page Designs* using *Cascading Style Sheets*.

CO3: Code *Client Server Interaction Programs* using *Java Based Server Technology* named *Servlets*.

CO4: Create *Dynamic Web Pages* where in *Client Interaction* is facilitated using *Advanced Server Technology* like *JSP*.

CO5: Integrate *Offline Data Storage, Background Processes* and *APIs* using *Database Connectivity* and *ASP*.

Syllabus

Course Details

HTML:

1. Develop HTML code to provide intra document linking. (BTL6)
2. Develop HTML code to provide inter document linking. (BTL6)

3. Develop a program to implement the three types of lists. (BTL6)
4. Create a HTML page using frames. (BTL6)
5. Develop a program to embed college picture into your web page and develop a short note on your college using paragraph tag. (BTL6)

6. Illustrate a suitable example; depict how we can align text using a table tag as follows. (BTL2)

II M.C.A	Pass percentage=95%
	Fail percentage=5%
III M.C.A	Pass percentage=97%
	Fail percentage=3%

7. Develop a program to create the time table as follows: (BTL6)

	1	2	3		4	5	6
MON	<-----WEB LAB----->			B R E A K	SE	WEB	PPL
TUE	UML	CRY	SE		<-----VB LAB----->		
WED	WEB	SE	UML		CRY	PPL	
THU	CRY	WEB	PPL		<-----WEB LAB----->		
FRI	<-----VB LAB----->				PPL	WEB	UML
SAT	SE	CRY	UML		<-----SEMINARS----->		

8. Create a Registration form that interacts with the user. Collect login name, password, date of birth,sex, address, qualification and display a “Thank you for registering” message when the user submits the form. (BTL6)

Login name:
 Enter Password:
 Reenter Password:
 Birthdate:
 Sex: Male Female
 Enter Address:
 Enter qualification:

Java Script:

9. Develop a script to compare two strings using String object. (BTL6)
10. Develop a script to generate random numbers within 1 to 10 and display the numbers in a table. (BTL6)
11. Develop a Java Script to update the information into the array, in the “onClick” event of the button “Update”. (BTL6)
12. Create a web page for a shopping mall that allows the user to tick off his purchases and obtain the bill with the total being added up simultaneously. (BTL6)

Item details	Price of item	Click here to select
	8399	<input type="checkbox"/>
	5000	<input checked="" type="checkbox"/>
	450	<input checked="" type="checkbox"/>
	399	<input type="checkbox"/>
YOUR TOTAL BILL IS 5450		

13. Develop a script to find the duplicate elements of an array. (BTL6)
14. Develop a script which generates a different greeting each time the script is executed. (BTL6)
15. Develop a JavaScript to check the number is Armstrong number or not by getting the number from textbox and the result is displayed in a alert dialog box. (BTL6)
16. Develop a java script code that accepts user name and password from user, Check their correctness and display appropriate alert messages. (BTL6)

DHTML:

17. Create an inline style sheet. Illustrate the use of an embedded style sheet. (BTL6)
18. Create an external style sheet to illustrate the “Font” elements. (BTL6)
19. Develop a program to switch on and off light using onClick event. (BTL6)
20. Illustrate different types of filters (at least six) on a sample text. (BTL2)
21. Develop a program to illustrate tabular data control for data binding. (BTL6)

XML:

22. Create a small XML file designed to contain information about student performance on a module. Each student has a name, a roll number, a subject mark and an exam mark. (BTL6)
23. Create a internal DTD file. (BTL6)
24. Create an external DTD file. (BTL6)
25. Create a XSLT style sheet to display the student data as an HTML table. (BTL6)

PHP:

26. Illustrate PHP declarations and expressions to find factorial of a given number using. (BTL2)
27. Develop a PHP program that interacts with the user .Collect first name last name and date of birth and displays that information back to the user. (BTL6)
28. Develop a PHP program to connect MySQL Database.(BTL6)

JSP:

29. Develop a program to implement JSP directives. (BTL6)
30. Develop a JSP program for session tracking. (BTL6)

Prescribed Textbook			
	Author	Title	Publisher
1	N.P.Gopalan, J.Akilandeswari	Web Technologies-A Developer's Perspective	PHI(2008)
2	Harvey M. Deitel and Paul I. Deitel	Internet and World Wide Web How To Program, 5e	Prentice Hall; 4th edition

Course Focus: Employability

Websites of Interest:

1. <https://www.w3schools.com>
2. <https://www.edx.org/learn/web-development>
3. <https://www.codecademy.com/learn/paths/web-development>



A.G & S.G Siddhartha Degree College of Arts & Science
Vuyyuru – 521165
(An Autonomous College in the jurisdiction of Krishna University)
NAAC reaccredited at ‘A’ level

Programme: M.Sc.(Computer Science)

Title of the Paper: Data Mining Lab

Semester: III

Course Code	20CS3L2	Course Delivery Method	Class Room / Blended Mode
Credits	4	CIA Marks	30
No. of Lecture Hours / Week	8	Semester End Exam Marks	70
Total Number of Lecture Hours	90	Total Marks	100
Year of Introduction : 2021-22	Year of Offering : 2021-22	Year of Revision : 2021-22	Percentage of Revision: Nil

Course Objective:

The main objective of this lab is to impart the knowledge on *How to implement Data Mining Algorithms using Various Tools* and *How to characterize the kinds of Patterns* that can be discovered by *Association Rule Mining, Classification, Clustering, Identifying Outliers* and *Emphasize Hands-on Experience* working with all *Real Time Data Sets*.

Course Outcomes: On successful completion of this course, the students will be able to

CO1: Understand the *Various Kinds of Tools*.

CO2: Apply *Mining Techniques* for *Realistic Data*.

CO3: Understand the *Basic Concepts* in R and *Weka*.

CO4: Understand how to import and export *CSV Files* and *Package* installation in R.

CO5: Develop and visualization of *Data Mining Algorithms* in R.

Using Weka Tool:

1. How to create and load *Data Set* in *Weka*. (BTL1)
2. Interpret all the *Categorical (or Nominal) Attributes* and the *Real-Valued Attributes* separately. (BTL2)
3. Construct *Association Rules* using *Weka*.(BTL6)
4. Construct *Multilayer Perceptron* or *Neural Network*. (BTL6)
5. Construct *Time Series Forecasting* using *Weka*. (BTL6)
6. Demonstration of preprocessing to remove *Attributes, Instances* and *Perform Discretization* using dataset *weather.arff*. (BTL2)
7. Create *K-Mean Clustering* using *Weka*.(BTL6)
8. Develop *Decision Tree* by training data set using *Weka*. (BTL6)
9. Create *Hierarchical Clustering* using *Weka*. (BTL6)
10. Identifying and removing *Outliers* using *Weka*. (BTL1)

Using R Programming:

1. How to import data into R from text and excel files using *read.table()* and *read.csv* functions. (BTL1).
2. Create *Association Rules* using *Aprior Algorithm* in R. (BTL6)
3. Construct *Multilayer Perceptron* or *Neural Network* using R. (BTL6)
4. Apply *Time Series Analysis* using R. (BTL3)
5. Apply *Time Series Forecasting* using R. (BTL3)
6. Apply *Time Series Decomposition* using R. (BTL3)
7. Create *K-Means Clustering Algorithm* using R. (BTL6)
8. Construct *Decision Tree* in R using package *party*. (BTL6)
9. Create *Hierarchical Clustering* using R. (BTL6)
10. Create *Hierarchical Clustering with Euclidean Distance* using R. (BTL6)
11. Examine *K-Medoids* clustering using R. (BTL4)
12. *Detecting and Removing* outliers using R. (BTL1)
13. Construct *Density Based Clustering* using R. (BTL6)
14. Illustrate *Linear Regression* using R. (BTL2)
15. Illustrate *Multiple Regression* using R. (BTL2)
16. Illustrate *Logistic Regression* using R. (BTL2)
17. Construct *Outlier Detection by Clustering* using R. (BTL6)
18. *Detecting and Removing Missing values* in R. (BTL1)
19. Create different kinds of *Charts* using *Sample Data Sets* in R. (BTL6)
20. Create *Word Cloud* using R. (BTL6)

Websites of Interest :

1. <https://www.cs.waikato.ac.nz/ml/weka>.
2. <https://weka.wikispaces.com>
3. <https://www.rdocumentation.org/packages/stats/versions/3.6.2>
4. <http://www.r-bloggers.com/>

Course Focus: Foundation / Employability / Skill Development.

APPENDIX - III
OPEN ELECTIVES OFFERED BY COMPUTER SCIENCE DEPARTMENT



A.G & S.G Siddhartha Degree College of Arts & Science
Vuyyuru – 521165
(An Autonomous College in the jurisdiction of Krishna University)
NAAC reaccredited at ‘A’ level

Programme:

Title of the Paper: Visual Analytics for Executives

Semester: III

Course Code	21CS3OEL1	Course Delivery Method	Face-to-face/Blended Mode
Course Category	Open elective	Lecture-Tutorial-Practice	2-0-4
Credits	4	CIA Marks	30
No. of Lecture Hours / Week	6	Semester End Exam Marks	70
Total Number of Lecture Hours	60	Total Marks	100
Year of Introduction : 2021-22	Year of Offering: 2021-22	Year of Revision: 2021-22	Percentage of Revision: Nil

Course Objectives : This Course focuses to know the *Importance of Visualization in the world of Data Analytics and Prediction, To handle Data Sources in Tableau, To get familiarized about creating visualization using different Types of Charts, To gain knowledge about using Maps in Tableau, To gain knowledge about Analysis, To design Interactive Dash Boards.*

Course Outcomes : At the end of this course, students should be able to:

CO1 : Able to know the importance of *Visualization* and connect *Different Data Sources in Tableau.*

CO2 : Able to create *Charts* in *Tableau.*

CO3 : Able to implement *Aggregate Functions, Calculated Fields, Table Calculations* and *Level of Detail Calculations.*

CO4 : Able to implement *Maps* and *Advance Analytic.*

CO5 : Able to create *Interactive Dash Boards.*

Syllabus		
Unit	Learning Units	Lecture Hours
I	<p>Introduction and Getting Started with Tableau: The Advantages of a Modern Analytics Platform, The Tableau Application Suite, Installing Tableau Desktop Data Preparation, The Sample Dataset, The Tableau Workspace, Working With Measures and Dimensions. Working With Marks, Saving, Opening, And Sharing Your Workbooks.</p> <p>Adding Data Sources in Tableau: Setting up a Data Connector, Selecting Data Tables, Joins, Unions, Data Extracts and Live Connections, Editing The Model's Metadata, Data Types, Adding Hierarchies, Calculated Fields and Table, Calculations, Data Collection.</p>	12
II	<p>Creating Data Visualizations: Chart Types, Ready, Set, Show Me, Bar Charts, Legends, Filters and Hierarchies,, Line Charts, Highlight Tables, Heatmaps, Bullet Charts, Cumulative Sums With Waterfall Charts, Reflection, The Anatomy of A Tableau Visualization.</p>	12
III	<p>Aggregate Functions, Calculated Fields, and Parameters: Aggregate Functions, Calculated Fields, Aggregations in Calculated Fields, Text Operators, Date Fields, Logical Functions In Calculated Fields, Parameters, Searching Text Fields.</p> <p>Table Calculations and Level of Detail Calculations: Different Types of Calculations, Quick Table Calculations, Customized Table Calculations, Level of Detail Expressions.</p>	12
IV	<p>Maps: Symbol Maps, Filled Maps, Density Maps, Map Layers, Maps With Pie Charts, Viz in Tooltip.</p> <p>Reflection: The Anatomy of a Tableau Map, Alternative Map Services, Mapbox Maps, Spatial Data.</p> <p>Advanced Analytics: Trends, Forecasts, Clusters and Other Statistical Tools, Overview of The Tableau Analytics Pane, Constant, Average, Reference Lines, Trend Lines, Forecasts, Cluster Analysis.</p>	12
V	<p>Interactive Dashboards: Preliminary Considerations, Creating a New Dashboard, The Dashboard Pane, Placing Charts on the Dashboard, Dashboard Titles, Navigation Buttons, Dashboard Actions.</p>	12

Course has focus on : Employability

Websites of Interest :

1. Visual Analytics in Tableau | <https://www.youtube.com/watch?v=gEKQ3kigJsM>
2. Tableau Training for Beginners | Edureka <https://www.youtube.com/watch?v=aHaOlvR00So>
3. Tableau Training for Beginners | Simplilearn <https://www.youtube.com/watch?v=Wh4sCCZjOwo>
4. Tableau Full Course| <https://youtu.be/KA0QHWm0nWo>

Co-curricular Activities : Programming Contests, workshops & Quiz.

Lab List:

1. Tableau installation. (BTL1)
2. Tableau Introduction /Exploring Tableau. (BTL1)
3. Creating New Workbooks Opening Existing Workbooks in Tableau(BTL3)
4. Data Collection from various sources web/text/csv/JSON (BTL3)
5. Implementing joins and Unions (BTL3)
6. Creating Bar Chart. (BTL3)
7. Creating Pie Chart. (BTL3)
8. Creating Dual Axis Chart. (BTL3)
9. Creating Shared Axis. (BTL3)

10. Creating Cross Tab. (BTL3)
11. Creating Word Cloud. (BTL3)
12. Creating Scatter Plot. (BTL3)
13. Creating Bubble Chart. (BTL3)
14. Implementing Data Blending. (BTL3)
15. Implementing Word Cloud. (BTL3)
16. Implementing Aggregate Functions, Calculated Fields. (BTL3)
17. Implementing Table Calculations and Level of Detail Calculations. (BTL3)
18. Creating Maps. (BTL3)
19. Implementing Trend lines and analytics in Tableau. (BTL3)
20. Creating a Dash Board. (BTL3)

A.G & S.G Siddhartha Degree College of Arts & Science, Vuyyuru – 521165.
(An Autonomous College in the jurisdiction of Krishna University)
----- Programme – III Semester

Course Code: Title: Visual Analytics for Executives
(w.e.f admitted batch 2020-21)

Time: 4 Hours

Answer ALL questions

Max. Marks: 70

Part A
Theory
(5×4 = 20 Marks)
Answer All Questions

1. What is *Dimension and Measure*? (BTL1)
2. Explain *Joining Tables* with *Tableau* with example. (BTL2)
3. Explain the role of *Table Data Extract*. (BTL2)
4. How to *Replace Tableau's Standard Maps*? (BTL1)
5. What is *Cluster Analysis*? (BTL2)

Part B (Practical)
(2×25 = 50 Marks)
Answer all Questions

1. a. Creating word clouds using Tableau. (BTL6)
b. Create a dual axis chart using Tableau. (BTL6)
2. Creating a Simple Dash Board using Tableau. (BTL6)



A.G & S.G Siddhartha Degree College of Arts & Science
Vuyyuru – 521165
 (An Autonomous College in the jurisdiction of Krishna University)
 NAAC reaccredited at ‘A’ level

Programme:

Title of the Paper: Web Programming

Semester: III

Course Code	21CS3OEL2	Course Delivery Method	Class Room / Blended Mode
Credits	4	CIA Marks	30
No. of Lecture Hours / Week	4	Semester End Exam Marks	70
Total Number of Lecture Hours	60	Total Marks	100
Year of Introduction : 2021-22	Year of Offering: 2021- 22	Year of Revision: 2021-22	Percentage of Revision: 0%

Course Objective: To provide knowledge on *Web Architecture, Web Services, Client Side and Server Side Scripting Technologies*, To focus on the development of *Web Based Information Systems and Web Services*, To provide skills to design *Interactive and Dynamic Web Sites*.

Course Outcomes: On successful completion of the course student will be able to:

CO1: Understand the *Web Architecture and Web Services*.

CO2: Design *Interactive Web Pages* using *HTML and Style Sheets*.

CO3: Design *Interactive Web Pages* using *Forms and Tables*.

CO4: Study about *CSS and XML*.

CO5: Create a *Website* using *Wix Platform*.

Syllabus

Course Details

Unit	Learning Units	Lecture Hours
I	<p>Introduction: What is Internet, History of Internet, Internet Services and Accessibility, Uses of the Internet, Protocols, Web Concepts: The Client/Server Model, Retrieving Data from the Web, How the Web Works?, Web Browsers, Searching information on the Web, Internet Standards.</p> <p>Internet Protocols: Internet Protocols, Host Names, Internet Applications And Application Protocols, Email Protocols.</p> <p>World Wide Web: Basics of WWW and Browsing, URL, Types of Browsers, Features of Browsers.</p>	12

II	<p>Introduction to HTML: HTML Document Structure, Creating Headings on Webpage.</p> <p>Working with Links: Creating Hyper Link, Setting The Hyper Link Colors, Linking Different Sections of Web Page.</p> <p>Working with images: Inserting an Image, Displaying alternate Text for an Image, Adding a Border, Aligning an Image, Using Image as Links, Image Maps.</p> <p>Working with tables: Creating a Table, Specifying Caption to a Table, Adding a Table Heading and Border, Aligning a Table and Cell Content, Setting The Width of a Table And Table Columns.</p>	12
III	<p>Forms: Creating Forms, Named Input Fields, The <INPUT> Tag, Multiple Lines Text Windows, Drop Down and List Boxes, Text, Text Area, Password, Button, Submit, Reset, Radio, Checkbox, Select Option, Labeling Input Fields, Grouping Related Fields, Disabled and Read Only Fields.</p> <p>Frames: Introduction to Frames, Frames Document, The <FRAMESET> Tag, Nesting <FRAMESET> Tag, Placing Content in Frames with the <FRAME> Tag, Targeting Named Frames.</p>	12
IV	<p>CSS: Introduction to Style Sheets, Inline Styles, External Style Sheets, Internal Style Sheets, Style Classes, Multiple Styles.</p> <p>XML: Introduction, HTML vs. XML, Syntax of XML Document, XML Attributes, Use of Elements vs. Use of Attributes, XML Validation, Well Formed XML Documents, Valid XML Documents, XML DTD: Internal DTD, External DTD, The Buildings Blocks of XML Documents.</p>	12
V	<p>Make a Website with Wix: Planning your Wix Website Design, Planning your Website Pages Working, Planning your Website Pictures, Videos and Logos, Wix Signup and Selecting a Premade or Blank Template.</p> <p>Building Your Wix Website: Getting to know Wix platform, Getting to know Wix editor, Designing the Header, Footer and Menu, Background for Pages and Sections, Adding Text, Adding Photos, Adding Videos, Adding Icons, Shapes and Boxes, Adding Links, Adding Forms, Adding a Wix Store, Adding a Lightbox.</p>	12

Prescribed Textbook			
	Author	Title	Publisher
1	N.P.Gopalan, J.Akilandeswari	Web Technologies-A Developer's Perspective	PHI(2008)

Reference Text Book			
	Author	Title	Publisher
1	Harvey M. Deitel and Paul I. Deitel	Internet and World Wide Web How To Program, 5e	Prentice Hall; 4th edition
2	Thomas Powell	Web Design The Complete Reference	TMH Tata McGraw Hill

Course Focus: Employability

Websites of Interest:

1. <https://www.w3schools.com/html/default.asp>
2. <https://www.udemy.com/course/wix-master-course-make-a-website-in-1-day-with-wix>

A.G & S.G Siddhartha Degree College of Arts & Science, Vuyyuru – 521165.
(An Autonomous College in the jurisdiction of Krishna University)

----- Programme - III Semester

Course Code:

Title: Web Programming

(w.e.f admitted batch 2020-21)

Time: 3 Hours

Max. Marks: 70

Answer ALL questions

(10×2 = 20 Marks)

1. a. What is *Web Browser*? Explain it? (BTL1)
- b. What is the *Functionality of HTTP*? (BTL1)
- c. Compare *Tag* and *Attributes* with example. (BTL2)
- d. Describe how you will *Embed Images* in Web document. (BTL1)
- e. Why do we use *<frameset>*? (BTL1)
- f. Write tag for *Drop Down*. (BTL1)
- g. Develop an *Inline Style Sheet* with suitable example.(BTL3)
- h. What is the *Syntax of XML*? (BTL1)
- i. How to *Plan a Website Design*? (BTL1)
- j. Explain *adding a photo* in *Wix Platform*. (BTL2)

Answer Five Questions Choosing One Question from Each Unit.

All Questions Carry Equal Marks.

(5×10 = 50 Marks)

Unit I

- 2) a) Explain various *Services Offered by Internet* and the *Types Of Internet Connections*. (BTL2)
- (or)
- b) Explain about *Internet Protocols*. (BTL2)

Unit II

- 3) a) What is the structure of *HTML Document*? Explain with example. (BTL1)
- (or)
- b) How to *Create A Table in HTML* with various *Attributes*? (BTL1)

Unit III

- 4) a) Discuss *Frame Set* and *Frame Attributes* by writing Program. (BTL6)
- (or)
- b) Develop a *Form* with *Various Tags* with suitable example. (BTL6)

Unit IV

- 5) a) What are *Types of CSS*? Explain with example. (BTL2)
- (or)
- b) What are *Well Formed* and *Valid XML Documents*? (BTL2)

Unit V

- 6) a) Explain Planning of *Wix Website Pages Working, Website Pictures, Videos and Logos*. (BTL5)
- (or)
- b) Explain *creating a Website* using *Wix Platform*. (BTL5)

APPENDIX - IV
ADD ON COURSE

Applicable for the batch of students applicable during the Academic Year 2021-2022										
M.Sc.(Computer Science)										
III SEMESTER					Add on Course					
S.No.	Course Code	Title of the Course	Instructional Hours per Semester			Credits	Evaluation			Total Marks
			L	T	P		CIA Marks	SEE		
								Marks	Duration	
1	20CS3A1	PHP with My SQL Certification			45	4	Nil	Nil	3 Hours	Nil
CIA=Continuous Internal Assessment					SEE=Semester End Examinations					

**AG & SG SIDDHARTHA DEGREE COLLEGE OF
ARTS & SCIENCE (AUTONOMOUS)VUYYURU-
521165**

Aided by the Government of A.P, Re-Accredited by NAAC with 'A' Grade

2021-2022



PG Department of Chemistry



Minutes of the meeting of Board of Studies

11-11-2021

MINUTES OF BOARD OF STUDIES

Minutes of meeting of Board of studies in PG Department of Chemistry held on 11-11-2021 at 7.00 pin in the PG Department of Chemistry through online (Google meet)

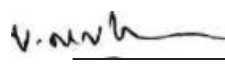
Members Present

S.No	NAME		Signature
1	Dr. V.Sreeram Head, Dept. of Chemistry(P.G) AG & SG S College, Vuyyuru.	Chairman	
2	Prof.C.Suresh Reddy Department of Chemistry S.V. University, Tirupati.	University Nominee	
3	Prof. Koya Prabakar Rao Department of Chemistry Vignan University, Guntur.	Subject Expert	
4	Dr.M.Sivanath Associate prof. Dept. of Chemistry A.N.R.College, Gudivada.	Subject Expert	
5	Dr.G.Raja Manager(Q.A) Biophore India pharamaceuticals. Hyderabad.	Representative from Industry	
6	Abdul Raheem	One Post Graduate Meritorious Aluminous nominated by the Principal	
7	N.V.Srinivasa Rao Department of Mathematics AG & SG S College, Vuyyuru.	Representative Science Faculty Other Dept.	
8	V.N.V.Kishore Dept. of Chemistry(P.G) AG & SG S College, Vuyyuru	Member	
9	Dilshad Begum Dept. of Chemistry(P.G) AG & SG S College, Vuyyuru	Member	
10	M.Rekha Dept. of Chemistry(P.G) AG & SG S College, Vuyyuru	Member	

AGENDA:

1. To Review and modified syllabus and model question papers, discuss & approve modalities of lab courses.
2. To suggest methodologies for innovative methods of teaching
3. Any other matter with the permission of the Chair
4. Molecular Spectroscopy, Rotational Vibrational Spectroscopy, Symmetry and Group theory in chemistry in paper I semester I
5. To recommend the changed syllabus potentiometry V in semester I

Resolutions

Resolution –I

1. Resolved to recommend the framed Syllabus & Model Question Papers for theory courses of SEM III and approve the modalities of Lab Courses as prescribed by BOS members.
2. Resolved to conduct assignments etc., for Internal Assessment Tests.
3. It is resolved to change the syllabus in III, IV, V units namely Introduction to Molecular Spectroscopy, Rotational Vibrational Spectroscopy, Symmetry and Group theory in chemistry in paper I semester I
4. It is resolved to add potentiometry in paper IV of semester I

4 Resolution –II

Resolved to adopt online teaching methods like as ZOOM, Microsoft teams, Google meet etc for ICT (Information and communication technologies) teaching

Resolution –III

5. Nil



BOS Meeting- PG Chemistry-11-11-2021, 7.00PM.through Online (Google Meet) Syllabus

approval letter through mail.

1 Prof.C.Suresh Reddy

Dear Dr. Sreeram Greetings
of the day

Happy to participate In the today's BOS meeting. I have gone through the syllabus and it is fine. I am here with approving the same syllabus.

This is for your kind information and necessary action in this regard. Prof .C.Suresh Reddy

Prof. C. Suresh Reddy, FAPAS, MNASc Department of Chemistry

S.V.U. College of Sciences Sri

Venkateswara University

Tirupati-517 502, A.P., India

Mobile: 98496949582

.Prof.K.prabhakara Rao

Dear sir,

I am here accepting the proposed syllabus. Thank you. Warm regards

Prof. KoyaPrabhakara Rao

Ph.D. (IIT Madras) (Postdoc-Japan 5yrs)

Head, Division of Chemistry # VGF-

8&9A, H-Block

Department of Science and Humanities VFSTR (Deemed to be University), Vadlamudi,

Guntur Dt, Pincode: 522213, Andhra Pradesh India. Phone (Office): 918632344762,

Mobile: +919676157858

Email: drkpr_sh@vignan.ac.in;

kprao2005@gmail.com website1: <https://sites.google.com/site/drkoyaprabhakararaowebiste/> website2: <http://www.vignan.ac.in/bshprabhakararao.php>

3.Dr.M.Sivanath

I have gone through your mail regarding the Third & First semester and open electiveSyllabus.

It is fine and approved.

This is for your kind information and necessary action in this regard. Warm regards

Dr.M.Sivanath,

Associate prof., Dept. of Chemistry, sivanath23@gmail.com

Vice principal, Additional Director, ANR College, Gudivada

A.G. & S.G.SIDDHARTHA DEGREE COLLEGE OF ARTS & SCIENCE
(Autonomous)
DEPARTMENT OF CHEMISTRY
M.Sc – CHEMISTRY (ORGANIC CHEMISTRY)

Appendix - I

Scheme of Instruction and Evaluation for **M.Sc. (Organic Chemistry)** programme for the batch of students admitted during 2021–2022

Semester – I

Paper	Title of the Paper	Instruction Hours Per Week			Credits(T+P)	Evaluation		
		L	T	P		CIA MARKS	SEE	
							MARKS	DURATION
Paper-I	General Chemistry	4	1	--	4	30	70	3 hours
Paper-II	Inorganic Chemistry - I	4	1	--	4	30	70	3 hours
Paper-III	Organic Chemistry - I	4	1	--	4	30	70	3 hours
Paper-IV	Physical Chemistry - I	4	1	--	4	30	70	3 hours
Pract-I	Inorganic Chemistry	--	--	6	3	30	70	6 hours
Pract-II	Organic Chemistry	--	--	6	3	30	70	6 hours
	Sub-Total	16	4	12	16+4+12=32			

A.G.& S.G. SIDDHARTHA DEGREE COLLEGE OF ARTS & SCIENCE

Vuyyuru- 521165.

NAAC reaccruited at 'A' level

Autonomous -ISO 9001 – 2015 Certified

Title of the Paper: GENERAL CHEMISTRY

Semester: I

Course Code	20CH1T1	Course Delivery Method	Class Room / Blended Mode - Both
Credits	4	CIA Marks	30
No. of Lecture Hours / Week	4	Semester End Exam Marks	70
Total Number of Lecture Hours	60	Total Marks	100
Year of Introduction :2020-21	Year of Offering: 2021 - 22	Year of Revision: 2021-22	60%

Course Objective: The main objective of this paper is to give abasic and updated knowledge for the students on Treatment of analytical data, Titrimetric Analysis, Rotational-Vibration Spectroscopy, Symmetry and Group theory in chemistry.

Course Outcomes:-

CO1: Recollect the concepts of titrimetric analysis, specific statistical rules, microwave Spectroscopy, rotational vibrational spectroscopy and group theory in chemistry

CO2: Identify the role of titrimetric analysis, specific statistical rules, microwave spectroscopy, Rotational vibrational spectroscopy and group theory in chemistry.

CO3: Demonstrate knowledge of titrimetric analysis, microwave spectroscopy, rotational Vibrational spectroscopy and group theory in chosen job role.

CO4: Test the conceptual knowledge gained in titrimetric analysis, statistical rules / principles, Microwave spectroscopy, rotational vibrational spectroscopy and group theory in chemistry

Syllabus

Course Details:-

Unit	Learning Units	Lecture Hours
I	Treatment of analytical data : Classification of errors – Determinate and indeterminate errors –Minimisation of errors – Accuracy and precision – Distribution of random errors – Gaussian distribution – Measures of central tendency – Measures of precision – Standard deviation – Standard error of mean – student's t test – Confidence interval of mean – Testing for significance – Comparison of two means – F – test – Criteria of rejection of an observation – propagation of errors – Significant figures and computation rules – Control charts – Regression analysis – Linear least squares analysis.	12
II	Titrimetric Analysis: Classification of reactions in titrimetric analysis- Primary and secondary standards-Neutralisation titrations- Theory of Neutralization indicators-Mixed indicators- Neutralisation curves- Displacement titrations-Precipitation titrations-Indicators for precipitation titrations-Volhard method-Mohr method- Theory of adsorption indicators- Oxidation reduction titrations-Change of electrode potentials during titration of Fe(II) with Ce(IV)- Detection of end point in redox titrations- Complexometric titrations- Metal ion indicators-Applications of EDTA titrations-Titration of cyanide with silver ion.	12
III	Introduction to Molecular Spectroscopy: Motion of molecules- Degrees of freedom –Energy associates with the degrees of freedom-Type of spectra. Microwave spectroscopy: Classification of molecules, rigid rotator model, effect of isotopic substitution on the transition frequencies, Intensities non- rigid rotator-Microwave spectra of polyatomic molecules.	12
IV	Rotational Vibrational Spectroscopy: Harmonic oscillator, vibrational energies of diatomic molecules, zero-point energy, force constant and bond strengths, anharmonicity, Morse potential energy diagram. Vibration – rotation spectroscopy. PQR branches, Born–Openheimer approximation, selection rules, normal modes of vibration, group frequencies, overtones, hot bands,applications.	12

V	Symmetry and Group theory in chemistry: Symmetry elements, symmetry operation, definition of group, sub group, relation between order of a finite group and its sub group. GMT tables Abelian and non-abelian groups. Point group. Schonfiles symbols, Find out Point group of a molecule (yes or no Method). Representation of groups by Matrices (representation for the C_n , C_{nv} , C_{nh} , D_n etc. groups to be worked out, explicitly). Character of a representation. The great Orthogonality theorem (without proof) and its importance. Character tables and their use. Construction of Character tables.	12
---	---	----

Reference Books:

1. Vogel's text book of quantitative analysis. (3rd edition) Addition Wesley Longmann Inc.
2. Quantitative analysis R.A Day and A.L. Underwood. Prentice Hall Pvt. Ltd.
3. Fundamentals of Analytical Chemistry – Skoog and West
4. Instrumental Methods of analysis – B K Sharma.

Course Focus: Employability & Entrepreneurship.

**A.G.& S.G.SIDDHARTHA DEGREE COLLEGE OF ARTS & SCIENCE Vuyyuru-
521165.**

NAAC recredited at 'A' level
Autonomous -ISO 9001 – 2015 Certified

Title of the Paper: INORGANIC CHEMISTRY-I

Semester: I

Course Code	20CH1T2	Course Delivery Method	Class Room / Blended Mode - Both
Credits	4	CIA Marks	30
No. of Lecture Hours / Week	4	Semester End Exam Marks	70
Total Number of Lecture Hours	60	Total Marks	100
Year of Introduction :2020-21	Year of Offering: 2021 - 22	Year of Revision: 2021-22	Percentage of Revision: 0%

Course Objective: The main objective of this paper is to give a basic and updated knowledge for the students on Quantum Mechanics, Chemistry of non-transition elements, Structure and Bonding, Metal-ligand bonding, Metal-ligand Equilibrium solutions.

Course Outcomes:-

After completion of the course, the student will be able to

CO1: Memorize the basic concepts of Quantum chemistry, Co-ordination chemistry and Chemical Bonding.

CO2: Comprehend the role of basic and advanced concepts of Quantum chemistry, Co-ordination Chemistry and Chemical bonding.

CO3: Execute the conceptual knowledge gained in the concepts of Quantum chemistry, Co-ordination Chemistry and Chemical bonding in chosen job role

CO4 : Compare and distinguish one concept from the other in inorganic chemistry and in correlation With other chemistries as well

Syllabus

Course Details

Unit	Learning Units	Lecture Hours
I	<p>Introduction to Exact Quantum Mechanical Results: Schrodinger equation, importance of wave function, Operators, Eigen values and Eigen functions, derivation of wave equation using operator concept. Discussion of solutions of Schrodinger's equation to some model systems viz. particle in one dimensional box (applications), three-dimensional box, Rigid rotator system and the Hydrogen atom. Variation theorem, linear variation principle, perturbation theory (first order and non-degenerate), Application of variation method to the Hydrogen atom</p>	12
II	<p>Chemistry of non- transition elements: Halogen oxides and oxyfluorides, Spectral and Magnetic properties of Lanthanides and Actinides. Analytical applications of Lanthanides and Actinides. Synthesis, properties and structure of B-N, S-N, P-N cyclic compounds. Intercalation compounds.</p> <p>Metal π- complexes: preparation, structure and bonding in Nitrosyl, Dinitrogen and Dioxygen complexes.</p>	12
III	<p>Structure and Bonding: $p\pi$-$d\pi$ bonding, Bent's rule, Non-valence cohesive forces, VSEPR theory. Molecular Orbital theory, Molecular orbitals in triatomic (BeH_2) molecules and ions (NO_2^-) and energy level diagrams. Walsh diagrams for linear (BeH_2) and bent (H_2O) molecules</p>	12
IV	<p>Metal-ligand bonding: Crystal Field Theory of bonding in transition metal complexes-Splitting of d-orbitals in octahedral, tetrahedral, square planar, Trigonal bipyramidal and Square pyramidal fields.</p> <p>Tetragonal distortions - Jahn-Teller effect. Applications and limitations of CFT. Experimental evidences for covalence in complexes.</p> <p>Molecular Orbital Theory of bonding for Octahedral, tetrahedral and square planar complexes. π-bonding and MOT - Effect of π - donor and π -acceptor ligands on Δ_o. Experimental evidence for π - bonding in complexes</p>	12
V	<p>Metal – ligand Equilibria in solutions: Step wise and over all formation constants. Trends in stepwise constants (statistical effect and statistical ratio). Determination of formation constants by Spectrophotometric method (Job's method) and pH metric method (Bjerrum's).</p> <p>Stability correlations - Irwing -William's series. Hard and soft acids and bases (HSAB).</p>	12

Reference Books:

1. Inorganic Chemistry Huheey, Harper and Row.
2. Physical methods in inorganic chemistry, R.S. Drago. Affiliated East-West Pvt.Ltd.
3. Concise inorganic chemistry, J. D. Lee, ELBS.
4. Modern Inorganic Chemistry, W. L. Jolly, McGrawHill.
5. Inorganic Chemistry, K. F. Purcell and J. C. Kotz Holt Saunders international.
6. Concepts and methods of inorganic chemistry, B. E. Douglas and D.H.M.C.
7. Daniel, Oxford Press.
8. Introductory quantum mechanics, A. K. Chandra
9. Quantum Chemistry, R. K. Prasad.
10. Inorganic Chemistry, Atkins, ELBS
11. Advanced Inorganic Chemistry, Cotton and Wilkinson, Wiley Eastern
12. Quantum Chemistry, Levine.
13. Text book of Coordination chemistry, K. Soma Sekhar Rao and K.N.K. Vani, Kalyani Publishers.
14. Theoretical Inorganic Chemistry by G.S. Manku, Tata Mc Graw Hill, 2000, reprint.
15. Concise co-ordination chemistry, R. Gopal, Ramalingam, Vikas Publishing, House, 2014.
16. Inorganic Chemistry – Huheey, A. Keiter, L. Keiter, 4th edition, Pearson education, Asia.

Course Focus: Employability & Entrepreneurship.

A.G. & S.G. SIDDHARTHA DEGREE COLLEGE OF ARTS & SCIENCE Vuyyuru-521165.

NAAC re accredited at 'A' level
Autonomous -ISO 9001 – 2015 Certified

Title of the Paper: ORGANIC CHEMISTRY-I

Semester: I

Course Code	20CH1T3	Course Delivery Method	Class Room / Blended Mode - Both
Credits	4	CIA Marks	30
No. of Lecture Hours / Week	4	Semester End Exam Marks	70
Total Number of Lecture Hours	60	Total Marks	100
Year of Introduction :2020-21	Year of Offering: 2021 - 22	Year of Revision: 2021-22	Percentage of Revision: 0%

Course Objective: The main objective of this paper is to give abasic and updated knowledge for the students on Quantum Mechanics, Chemistry of non- transition elements, Structure and Bonding, Metal–ligand bonding, Metal–ligand Equilibriain solutions.

Course Outcomes:

After completion of the course, the student will be able to:

CO1: Recollectthebasicconceptsof aromaticity, reactiveintermediates, addition, eliminationand Substitutionreactions

CO2: Explainthebasicandadvancedconceptsof aromaticity, reactiveintermediates,addition, Elimination and substitution reactions.

CO3: Solvehighlevelconcepts inorganicchemistrywithconceptualknowledge gained inaromaticity, Reactiveintermediates, addition, eliminationandsubstitutionreactions

CO4: Exercisetheknowledgeaboutaromaticity, reactiveintermediates, addition, eliminationand Substitutionreactionsinunderstandingthepropertiesoforganiccompounds.

Syllabus

Course Details

Unit	Learning Units	Lecture Hours
I	<p>Nature of bonding: Localised and Delocalized, Delocalised chemical bonding conjugation, cross conjugation, hyper conjugation, Tautomerism.</p> <p>Aromaticity: Concept of Aromaticity, Aromaticity of five membered, six membered rings - Non benzenoid aromatic compounds:-cyclopropenylcation, Cyclobutadienyldication, cyclopentadienyl anion-tropyllium cation and cyclooctatetraenyl dianion. Homoaromaticity, Anti aromaticity</p>	12
II	<p>Reactive intermediates & Reactive Species:</p> <p>Reactive intermediates: Generation, Structure, Stability, Detection and Reactivity of Carbocations, Carbanions, Free radicals, Carbenes, Nitrenes and Arynes.</p> <p>Reactive Species: Generation and reactivity of Electrophiles, Nucleophiles, Dienophiles, Ylids.</p>	12
III	<p>Addition Reactions: Additions: Addition to carbon – carbon multiple bonds, HX, X₂, HOX, stereo chemistry of addition, formation and reaction of epoxides, syn and anti hydroxylation, hydrogenation(catalytic and Non catalytic), synthetic reactions of CO and CN and Cram's rule.</p>	12
IV	<p>Eliminations Reactions:Types of elimination (E₁, E_{1cB}, E₂) reactions, mechanisms, stereochemistry and orientation, Hofmann and Saytzeff's rules, Syn elimination versus anti elimination. Competitions between elimination and substitution. Dehydration, dehydrogenation, dehalogenation, decarboxylative elimination, pyrolytic eliminations.</p>	12
V	<p>Substitution Reactions:</p> <p>Aliphatic Nucleophilic substitutions:The S_N², S_N¹, mixed S_N¹ and S_N² and S_Nⁱ reactions : Mechanism, effect of structure, nucleophile, leaving group on substitutions. The neighbouring group mechanism, participation by σ and π bonds, anchimeric assistance.</p> <p>Aromatic Nucleophilic substitution:The S_N^{Ar} (Addition – Elimination), S_N¹(Ar) mechanisms and benzyne mechanism (Elimination – Addition). Reactivity- effect of substrate structure, leaving group and attacking nucleophile. The Von-Richter, Sommelet – Hauser and Smiles rearrangements.</p>	12

Reference Books:

1. Advanced organic chemistry- Reaction, mechanism and structure, Jerry March, John Wiley.
2. Advanced organic chemistry, F.A. Carey and R.J. Sundberg, Springer, New York.
3. A guide book to Mechanism in organic chemistry, Peter Sykes, Longman.
4. Organic chemistry, I.L. Finar, Vol. I & II, Fifth ed. ELBS.
5. Organic chemistry, Hendrickson, Cram and Hammond (McGraw –Hill).
6. Modern organic Reactions, H.O. House, Benjamin.
7. Structure and mechanism in organic chemistry, C.K. Ingold, Cornell University Press.
8. Principles of organic synthesis, R.O.C. Norman and J.M. Coxon, Blakie Academic & Professional.
9. Reaction Mechanism in Organic Chemistry, S.M. Mukherji and S.P. Singh, Macmillan.
10. Basic Principles of Organic Chemistry by J. B. Roberts and M. Caserio.

Course Focus: Employability & Entrepreneurship.

A.G.& S.G. SIDDHARTHA DEGREE COLLEGE OF ARTS & SCIENCE

Vuyyuru-521165.

NAAC recredited at 'A' level

Autonomous -ISO 9001 – 2015 Certified

Title of the Paper: PHYSICAL CHEMISTRY-I

Semester: I

Course Code	20CH1T4	Course Delivery Method	Class Room / Blended Mode - Both
Credits	4	CIA Marks	30
No. of Lecture Hours / Week	4	Semester End Exam Marks	70
Total Number of Lecture Hours	60	Total Marks	100
Year of Introduction : 2020-2021	Year of Offering: 2021 - 22	Year of Revision:2021-22	Percentage of Revision: 20%

Course Objective: The main objective of this paper is to give a basic and updated knowledge for the students on Thermodynamics, Surface phenomena and phase equilibria, Electrochemistry, Chemical kinetics, Potentiometry.

Course Outcomes:-

After the completion of the course, Students will be able to

CO1: Recall the basic concepts of thermodynamics ,surfacechemistry, electrochemistry,chemical Kinetics and potentiometry in detail.

CO2:Apply the spontaneous and nonspontaneous reaction and derive various thermodynamic and Chemical kinetic derivations.

CO3:Describe the physical significance of thermodynamics,chemicalkinetics and electrochemistry in Explaining the chemical properties, reactivity of molecules.

CO4:Analyse the important techniques of surfaces with the help of ESCA,Auger electronspectroscopy and potentiometric techniques of complexometric, neutralization, oxidation and reduction Titrations.

Syllabus

Course Details

Unit	Learning Units	Lecture Hours
I	<p>Thermodynamics - I Classical thermodynamics - Brief review of first and second laws of thermodynamics - Entropy change in reversible and irreversible processes - Entropy of mixing of ideal gases - Entropy and disorder – Free energy functions - Gibbs-Helmholtz equation - Maxwell partial relations - Conditions of equilibrium and spontaneity - Free energy changes in chemical reactions: Van't Hoff reaction isotherm - Van't Hoff equation - Clausius Clapeyron equation - partial molar quantities - Chemical potential - Gibbs- Duhem equation - partial molar volume - determination of partial molar quantities - Fugacity - Determination of fugacity - Thermodynamic derivation of Raoult's law..</p>	12
II	<p>Surface phenomena and phase equilibria - Surface tension - capillary action - pressure difference - across curved surface (Young-Laplace equation) - Vapour pressure of small droplets (Kelvin equation) - Gibbs-Adsorption equation - BET equation - Estimation of surface area - catalytic activity of surfaces – ESCA , X- ray fluorescence and Auger electron spectroscopy.</p> <p>Surface active agents - classification of surface active agents - Micellization - critical Micelle concentration (CMC) - factors affecting the CMC of surfactants, microemulsions - reverse micelles - Hydrophobic interaction.</p>	12
III	<p>Electrochemistry – I - Electrochemical cells - Measurement of EMF - Nernst equation – Equilibrium constant from EMF Data - pH and EMF data - concentration cells with and without transference – Liquid junction potential and its determination - Activity and activity coefficients - Determination by EMF Method - Determination of solubility product from EMF measurements. Debye Huckel limiting law and its verification. Effect of dilution on equivalent conductance of electrolytes - Anomalous behaviour of strong electrolytes. Debye Huckel-Onsagar equation - verification and limitations, conductometric titrations.</p>	12
IV	<p>Chemical kinetics- Methods of deriving rate laws - complex reactions - Rate expressions for opposing, parallel and consecutive reactions involving unimolecular steps. Theories of reaction rates -collision theory - Steric factor - Activated complex theory - Thermodynamic aspects – Unimolecular reactions</p> <p>- Lindemann's theory - Lindemann-Hinshelwood theory. Reactions in solutions - Influence of solvent - Primary and secondary salt effects - Elementary account of linear free energy relationships - Hammett-Taft equation - Chain reactions - Rate laws of H₂-Br₂, photochemical reaction of H₂</p> <p>- Cl₂, Decomposition of acetaldehyde and ethane - Rice-Herzfeld mechanism.</p>	12

V	Potentiometry: Advantages of potentiometric methods - Reference electrode - Standard hydrogen electrode .Acid- alkali or Neutralisation titration, Oxidation – reduction titrations, Precipitation titrations, complexometric titrations, Methods of end point location (Graphical, Differentiation method, Pinkhof- Treadwell method). Calomel electrode -Indicator electrodes: Metal-metal ion electrodes - Inert electrodes -Membrane electrodes - theory of glass membrane potential - Direct potentiometry, potentiometric titrations - Applications.	12
---	---	----

Reference Books:

1. Physical Chemistry, G.K. Vemulapalli (Prentice Hall of India).
2. Physical chemistry, P.W. Atkins. ELBS
3. Chemical kinetics - K.J. Laidler, McGraw Hill Pub.
4. Textbook of Physical Chemistry, Samuel Glasstone, Macmillan pub.
5. Polymer Science, Gowriker, Viswanadham, Sreedhar
7. Elements of Nuclear Science, H.J. Arniker, Wiley Eastern Limited.
8. Quantitative Analysis, A.I. Vogel, Addison Wesley Longman Inc.
9. Physical Chemistry - G.W. Castellan, Narosa Publishing House, Prentice Hall
10. Physical Chemistry, W.J. Moore, Prentice Hall
11. Polymer Chemistry – Billmeyer

Course Focus: Employability & Entrepreneurship.

A.G. & S.G. SIDDHARTHA DEGREE COLLEGE OF ARTS & SCIENCE

Vuyyuru-521165.

NAAC recredited at 'A' level

Autonomous -ISO 9001 – 2015 Certified

Title of the Paper: Practical – I – Inorganic Chemistry (20CH1L1)

Semester: I

S.No	COURSE OUTCOMES	PO'S
	After completion of the course, the student will be able to :	
1	Memorize the basic principles involved in quantitative and qualitative inorganic analysis.	1,7
2	Understand the importance of inorganic qualitative and quantitative analysis and their use in research and industry.	2,6
3	Apply the procedures of quantitative analysis and tests for identification of cations and anions in chosen field.	1,5
4	Evaluate how far these methods are accurate in quantitative determination.	1,4

List of experiments:

1. Preparation of Potassium trisoxalato ferrate(III).
2. Preparation of Tris thiourea copper (I) sulphate.
3. Preparation of Cis and trans potassium diaquodioxalato chromate(III).
4. Preparation of Hexa ammine cobalt (III) chloride.
5. Determination of Zn^{2+} with potassium ferrocyanide.
6. Determination of Mg^{2+} using EDTA.
7. Determination of Ni^{2+} using EDTA.
8. Determination of hardness of water using EDTA.
9. Gravimetric determination of nickel using dimethylglyoxime.

10. Gravimetric determination of Zn using diammonium hydrogenphosphate.

11. Semi micro qualitative analysis of six radical mixtures

(One interfering anion and one less familiar cation for each mixture)

(minimum three mixtures).

Anions: S^{2-} , SO_3^{2-} , Cl^- , Br^- , I^- , NO_3^- , SO_4^{2-} , CH_3COO^- , CO_3^{2-} , $C_2H_3O_2^-$, PO_4^{3-} , CrO_4^{2-} , BO_3^{3-}

Cations: Ammonium (NH_4^+)

1st group: Ag^+ , Pb^{+2} , W^{+6}

2nd group: Pb^{+2} , Bi^{+3} , Cu^{+2} , Cd^{+2} , Sn^{+2} , Sn^{+4} , Mo^{+6} .

3rd group: Fe^{+2} , Fe^{+3} , Al^{+3} , Cr^{+3} , Ce^{+4} , Th^{+4} , Zr^{+4} , VO^{+2} , Be^{+2} .

4th group: Zn^{+2} , Mn^{+2} , Co^{+2} ,

Ni^{+2} . 5th group: Ca^{+2} , Ba^{+2} , Sr^{+2} .

6th group: Mg^{+2} , K^+ , Li^+ .

A.G. & S.G. SIDDHARTHA DEGREE COLLEGE OF ARTS & SCIENCE

Vuyyuru-521165.

NAAC re accredited at 'A' level

Autonomous -ISO 9001 – 2015 Certified

Title of the Paper: Organic Chemistry (20CH1L2)

Semester: I

S.No	COURSE OUTCOMES	PO'S
	After completion of the course, the student will be able to :	
1	Understand the importance of organic compounds synthesis and separation and their research and industry.	2,5,6
2	Understand the mechanisms for the synthesis of organic compounds in different steps.	1,7
3	Apply the procedure of synthesis and separation of organic compounds in required field.	1,5,7
4	Interpret the role of separation of organic compounds and synthesis in the core areas of research.	1,5,6

List of experiments:

1. Separation of Binary mixtures of Carboxylic acid + Neutral organic compounds (Solvent extraction method).
2. Separation of Binary mixtures of Basic nature + Neutral organic compounds (Solvent Extraction method).
3. Separation of Binary mixtures of Phenolic compounds + Neutral organic compounds (Solvent extraction method).
4. Preparation of Phthalimide from Phthalic anhydride – High Temperature.
5. Preparation of p-nitro acetanilide – Low temperature.
6. Preparation of Iodoform – Room temperature.

7. Paper chromatography - separate the given mixture of sugars.
8. Paper chromatography - separate the given mixture of amino acids.
9. Thin layer chromatography - separate the given mixture of phenols
10. Thin layer chromatography - separate the given mixture of 2,4-DNP derivatives of carbonyl compounds.

Text books/ Reference books:

1. A.I. Vogel, "A Text Book of Practical Organic Chemistry", Longman
2. A.I. Vogel, "Elementary Practical Organic Chemistry", Longman
3. F.G. Mann and B.C. Saunders, "Practical Organic Chemistry", Longman
4. Reaction and Synthesis in Organic Laboratory, B.S. Furniss, A.J. Hannaford, Tatchell, University Science Books mills valley.
5. Purification of Laboratory chemicals, manual, W.L.F. Armarego EDD Perrin
6. Reaction and Synthesis in Organic Chemistry Laboratory, Lutz-Friedjan-Tietze, Theophil Eicher, University Science Book.

A.G. & S.G. SIDDHARTHA DEGREE COLLEGE OF ARTS & SCIENCE

Vuyyuru-521165.

NAAC recredited at 'A' level

Autonomous -ISO 9001 – 2015 Certified

M.Sc. DEGREE EXAMINATION

FIRST SEMESTER

Paper-I :: General Chemistry - I

Time: 3 hours

Maximum Marks: 70

SECTION – A

Answer all the questions. Each question carries 2 marks. (10x2=20M)

1. Discuss the role of control charts in large scale production. (CO-2)
2. What are the measures of accuracy? (CO-1)
3. Explain the terms primary & secondary standards in titrimetric analysis. (CO-2)
4. Enumerate the significance of mixed indicators. (CO-2)
5. Give an account on classification of molecules in microwave spectroscopy. (CO-2)
6. Write a short note on degrees of freedom. (CO-2)
7. What are hot bands? (CO-1)
8. Define zero point energy and discuss its significance. (CO-2)
9. List out the possible symmetry elements and write the point group of the molecule HCHO. (CO-3)
10. Define a class. Explain with an example. (CO-2)

SECTION – B

(10x5=50M)

UNIT - I

11. a) Write notes on determinate errors. (CO-2)
- (Or)**
- b)(i) What are the criteria for rejection of an observation? (CO-2)
 - (ii) Write notes on significant figures and computational rules. (CO-2)

UNIT – II

12. a) Explain the theory of neutralization indicators. (CO-2)

(Or)

b) Describe the Volhard & Mohr method in precipitation titrations. (CO-2)

UNIT – III

13. a) Explain the electromagnetic spectrum and discuss the interaction of electromagnetic radiation with matter. (CO-2)

(Or)

b) Discuss the applications of microwave spectroscopy. (CO-3)

UNIT - IV

Elaborate the formation of PQR branches in vibrational rotational spectrum. (CO-3)

(Or)

b) What is Born – oppenheimer approximation? How a break down in approximation occurs? (CO-2)

UNIT - V

15.a) Enumerate the role of group theory in IR & Raman spectroscopy. (CO-3)

(Or)

b) Explain the construction of C_{2v} character table. (CO-2)

M.Sc. DEGREE EXAMINATION

FIRST SEMESTER

Paper-II :: Inorganic Chemistry - I

Time:3hours

Maximum Marks:70

SECTION – A

Answer all the questions. Each question carries 2 marks. (10x2=20M)

1. Explain the significance of approximation methods. (CO -2)
2. Define operator. Explain the significance of operators in quantum mechanics. (CO -2)
3. Discuss about Intercalation compounds. (CO -1)
4. Enumerate the significance of natural oxygen carriers. (CO -2)
5. Explain the role of VSEPR theory in predicting the geometry of molecule. (CO -2)
6. Give an account on important features of MO theory. (CO -2)
7. Explain the splitting of d-orbitals in square pyramidal crystal field. (CO -2)
8. Discuss the drawbacks of valence bond theory. (CO -1)
9. Derive a relation between stepwise and overall formation constants. (CO -3)
10. What is chelate effect? Explain with an example. (CO -2)

SECTION – B

(10x5=50M)

UNIT - I

11.a) Write down the wave equation for rigid rotor and solve it to get eigen functions. (CO-3)

(Or)

b) Arrive at the expression for first order correction of eigen values in perturbation method. (CO -3)

UNIT – II

12. a) Write an account on phosphorus-nitrogen cyclic compounds. (CO -2)

(Or)

b) Explain the structure and bonding in nitrosyl complexes. (CO -2)

UNIT – III

13. a) Draw and explain the molecular orbital energy level diagram for BeH_2 molecule. (CO-3)

(Or)

b) Explain the evidences for $p\pi - d\pi$ bonding in non-transition metal compounds. (CO-4)

UNIT - IV

14. a) Discuss tetragonal distortion in an octahedral complex with a suitable example. (CO -3)

(Or)

b) Why CN^- and CO cause greater crystal field splitting and I^- and Br^- cause lesser crystal

field splitting? Explain.

(CO -4)

UNIT - V

15. a) Describe the spectrophotometric method for the determination of stability Constant.

(CO -3)

(Or)

b) Give a detailed account on HSAB theory.

(CO -2)

M.Sc. DEGREE EXAMINATION

FIRST SEMESTER

Paper-III :: Organic Chemistry - I

Time:3hours

Maximum Marks:70

SECTION – A

Answer all the questions. Each question carries 2 marks. (10x2=20M)

1. Explain anti aromaticity with example. (CO - 1)
2. Explain cross conjugation with example. (CO - 2)
3. Explain the structure of nitrenes. (CO - 1)
4. Discuss the structure of carbenes (CO - 1)
5. Discuss Cram's rule with suitable examples. (CO - 2)
6. Write notes on epoxidation. (CO - 2)
7. Define Hoffmann's rule. Give suitable examples. (CO - 2)
8. Discuss syn elimination versus anti elimination. (CO - 2)
9. Give mechanism of Von-Richter rearrangement. (CO - 2)
10. Write notes on S_Ni mechanism. (CO - 1)

SECTION – B

(10x5=50M)

UNIT - I

11. a) Define delocalized chemical bonding. What are different types of delocalized chemical bonding. (CO - 2)

(Or)

- b) Explain the following terms (i) Cross Conjugation (ii) Hyper Conjugation. (CO - 2)

UNIT - II

12. a) Discuss the generation, stability and reactivity of carbocations. (CO - 3)

(Or)

- b) Explain synthesis and few reactions of the following

- (i) Free radicals (ii) Carbanions (CO - 2)

UNIT - III

13. a) Give an account of the addition of the following to carbon carbon multiple bonds (i)

HX (ii)HOX (CO - 2)

(Or)

b) Discuss in detail about the following

(i) Syn and Anti hydroxylation (ii) Hydrogenation (CO -1)

UNIT – IV

14. a) Discuss pyrolytic eliminations and its orientation. (CO -1)

(Or)

b) Write a detailed account of E1CB mechanism. (CO -1)

UNIT – V

15. a) What is anchimeric assistance. Discuss neighbouring group participation by

σ and π bonds. (CO -2)

(Or)

b) Explain the following (i) Benzyne mechanism (ii) S_N^Ar mechanism. (CO -2)

M.Sc. DEGREE EXAMINATION

FIRST SEMESTER

Paper-IV :: Physical Chemistry - I

Time:3hours

Maximum Marks:70

SECTION – A

Answer all the questions. Each question carries 2 marks.

(10x2=20M)

1. Explain the second law of thermodynamics. (CO-2)
2. Write the Gibbs Duham equation and describe all the terms present. (CO-2)
3. Discuss briefly the surface active agents. (CO-2)
4. Explain the microemulsions in brief. (CO-2)
5. Write the Nernst equation and describe all the terms present in it. (CO-2)
6. Explain the principle in conductometric titrations. (CO-2)
7. Write the mechanism in Lindemann's theory of unimolecular reactions. (CO-2)
8. Describe the mechanism in decomposition of Acetaldehyde. (CO-3)
9. Describe the advantages of potentiometric methods over classical methods. (CO-3)
10. Explain the calomel electrode in short. (CO-2)

SECTION-B

(10x5=50M)

UNIT - I

11. a) Derive the Maxwell's thermodynamic relations. (CO-3)

(Or)

- b) What is fugacity? Give its physical significance. Describe the different methods of determination of fugacity. (CO-3)

UNIT - II

12. a) Discuss the theory involved in ESCA. How are these techniques used in the analysis of surfaces? (CO-2)

(Or)

- b) What is CMC? How is it determined? What are the factors affecting CMC? (CO-2)

UNIT - III

13.a) What is activity? How is activity coefficient determined from EMF? (CO-2)

(Or)

b) What is the effect of dilution on equivalent conductance of electrolytes? (CO-2)

UNIT - IV

14.a) Discuss the kinetics of consecutive reactions. (CO-2)

(Or)

b) Discuss the kinetics of $H_2 - Br_2$ reaction in detail. (CO-3)

UNIT - V

15.a) Explain the theory of precipitation titrations in detail. (CO-2)

(Or)

b) Discuss the potentiometric titrations in detail. (CO-2)

A.G.& S.G.SIDDHARTHA DEGREE COLLEGE OF ARTS & SCIENCE

DEPARTMENT OF CHEMISTRY

M.Sc – CHEMISTRY (ORGANIC CHEMISTRY)

CIA Practicals

Total Marks – 30 M

M.Sc. DEGREE EXAMINATION

External Practical Model Paper

Time:6hours

Maximum Marks:70

1. To write the principle and procedure / mechanism related to practical as listed in the practical syllabus – 5M
2. Record – 10M
3. Experiment (Procedure / Tabulation / calculation etc.,) – 50M
4. Result / Graphs / Yield/Report – 5 M

A.G. & S.G.SIDDHARTHA DEGREE COLLEGE OF ARTS & SCIENCE
(Autonomous)
DEPARTMENT OF CHEMISTRY
M.Sc – CHEMISTRY (ORGANIC CHEMISTRY)

Appendix - I

Scheme of Instruction and Evaluation for **M.Sc. (Organic Chemistry)** programme for the batch of students admitted during 2020–2021

Semester – III

Paper	Title of the Paper	Instruction Hours Per Week			Credits(T+P)	Evaluation		
		L	T	P		CIA MARKS	SEE	
							MARKS	DURATION
Paper-I	Advanced Organic Spectroscopy	4	1	--	4	30	70	3 hours
Paper-II	Organic Reactions & Mechanisms	4	1	--	4	30	70	3 hours
Paper-III	Organic Synthesis	4	1	--	4	30	70	3 hours
Paper-IV	Chemistry of Natural Products	4	1	--	4	30	70	3 hours
Paper-V	Open Elective- (Polymer Chemistry)	4	--	--	4			
Pract-I	Organic Preparations	--	--	6	3	30	70	6 hours
Pract-II	Mixture Analysis	--	--	6	3	30	70	6 hours
	Sub-Total	20	4	12	20+4+12=36			

A.G. & S.G. SIDDHARTHA DEGREE COLLEGE OF ARTS & SCIENCE

Vuyyuru- 521165.

NAAC reaccredited at 'A' level

Autonomous -ISO 9001 – 2015 Certified

Title of the Paper: ADVANCED ORGANIC SPECTROSCOPY

Semester: III

Course Code	20CH3T1	Course Delivery Method	Class Room / Blended Mode - Both
Credits	4	CIA Marks	30
No. of Lecture Hours / Week	4	Semester End Exam Marks	70
Total Number of Lecture Hours	60	Total Marks	100
Year of Introduction :2020-21	Year of Offering: 2021 - 22	Year of Revision: ----	Percentage of Revision: 0%

Course Objective: The main objective of this paper is to give a basic and updated knowledge for the students on Proton & ^{13}C NMR Spectroscopy, Structural Elucidation of Organic compounds Using UV, IR, ^1H -NMR, ^{13}C -NMR, 2D NMR spectroscopy and Optical Rotatory Dispersion (ORD) & CD spectroscopy.

Course Outcomes:-

CO1: Summarize the principle, theory and advanced aspects of ^1H NMR, ^{13}C NMR, 2DNMR, ORD & CD spectroscopic techniques.

CO2: Display the knowledge gained in the areas of ^1H NMR, ^{13}C NMR, 2DNMR, ORD & CD Spectroscopic techniques in chosen job role.

CO3: Interpret the spectral data of ^1H NMR, ^{13}C NMR, 2DNMR, ORD & CD in elucidating the Structure of the molecule.

CO4: Assess how far the spectral data of ^1H NMR, ^{13}C NMR, 2DNMR, ORD & CD are useful in establishing the structure of the molecule.

Syllabus

Course Details:-

Unit	Learning Units	Lecture Hours
I	Proton NMR Spectroscopy: Determination of structure of organic compounds using PMR data. Spin system, Nomenclature of spin system, spin system of simple and complex PMR spectrum (Study of AB – A2 – AB2. ABX – ABC – AMX interactions) Simplification of complex spectra- nuclear magnetic double resonance, chemical shift reagents, solvent effects on PMR Spectrum . Nuclear Overhauser Effect (NOE).	12
II	¹³C-NMR spectroscopy: Similarities and Difference between PMR and CMR-CMR recording techniques -BBC-BBD-SFORD-Gate pulse CMR spectrum. General considerations, chemical shift (aliphatic, olefinic, alkyne, aromatic, heteroaromatic and carbonylcarbon), coupling constants. Typical examples of CMR spectroscopy – simple problems.	12
III	ORD & CD Curves: Optical rotatory dispersion : Theory of optical rotatory dispersion – Cotton effect –CD curves-types of ORD and CD curves-similarities and difference between ORD and CD curves. α - Halo keto rule, Octant rule – application in structural studies.	12
IV	2D NMR spectroscopy: Definitions and importance of COSY, DEPT, HOMCOR, HETCOR, INADEQUATE, INDOR, INEPT, NOESY, HOM2DJ, HET2DJ. Study of COSY ,DEPT, HOMCOR, HETCOR, INADEQUATE INDOR INEPT ,NOESY HOM2DJ, HET2DJ, taking simple organic compounds as examples.	12
V	Structural Elucidation of Organic compounds Using UV, IR, ¹ H-NMR, ¹³ C-NMR and Mass spectroscopy.	12

Reference Books:

1. Introduction to Spectroscopy – D. L. Pavia, G.M. Lampman, G. S. Kriz, 3rdEd. (Harcourt College publishers).
2. Spectrometric identification of organic compounds R. M. Silverstein, F. X. Webster, 6th Ed. John Wiley and Sons.
3. Spectroscopic methods in organic chemistry - D. H. Williams and I Flemming McGraw Hill, 4th edition.
4. Absorption spectroscopy of organic molecules – V. M. Parikh
5. Organic structural Spectroscopy- Joseph B. Lambert, Shurvell, Lightner, Cooks, Prentice-Hall (1998).
6. Organic structures from spectra –Field L.D., Kalman J.R. and Sternhell S. 4thEd. John Wiley and sons Ltd.
7. Organic spectroscopy – Principle & Applications – Jag Mohan, Narosa, 2nd edition, Publishinghouse.

Course Focus: Employability & Entrepreneurship.

A.G.& S.G.SIDDHARTHA DEGREE COLLEGE OF ARTS & SCIENCE

Vuyyuru-521165.

NAAC reaccredited at 'A' level

Autonomous -ISO 9001 – 2015 Certified

Title of the Paper: ORGANIC REACTIONS & MECHANISMS

Semester: III

Course Code	20CH3T2	Course Delivery Method	Class Room / Blended Mode - Both
Credits	4	CIA Marks	30
No. of Lecture Hours / Week	4	Semester End Exam Marks	70
Total Number of Lecture Hours	60	Total Marks	100
Year of Introduction :2020-21	Year of Offering: 2021 - 22	Year of Revision: -----	Percentage of Revision: 0

Course Objective: The main objective of this paper is to give a basic and updated knowledge for the students on Oxidations, Reductions, Molecular Rearrangements, Pericyclic Reactions and Organic Photo Chemistry.

Course Outcomes:-

- CO1 :** Acquire sound knowledge of oxidations, reductions, molecular rearrangements, pericyclic reactions and photochemistry.
- CO2 :** Understand the concepts involved in oxidations, reductions, molecular rearrangements, pericyclic reactions and photochemistry.
- CO3 :** Apply the conceptual knowledge gained in oxidations, reductions, molecular rearrangements, pericyclic reactions and photo chemistry in chosen fields.
- CO4 :** Analyse and categorise the various types oxidations, reductions, molecular rearrangements, pericyclic reactions and photo chemistry in a given reactions.

Syllabus

Course Details

Unit	Learning Units	Lecture Hours
I	Oxidations Definition and types of Oxidations, oxidations with ruthenium tetroxide, NBS, iodobenzene diacetate, Tl(III) nitrate, Chromium (VI) oxidants, Lead tetra acetate, SeO ₂ , MnO ₂ , Ag ₂ CO ₃ , Oppenauer oxidation, perhydroxylation using KMnO ₄ , OsO ₄ , HIO ₄ , oxidation with iodine silver carboxylate (Woodward and Prevost conditions), Definition & mechanism of epoxidation by peracids.	12

II	<p>Reductions</p> <p>Definition and types of reductions, reduction by dissolving metals - Reduction with metal and liquid ammonia (Birch Reduction of aromatic compounds), Reduction with metal acid - Clemensons reduction, Reduction by hydride transfer reagents, Aluminiumalkoxide - MeerweinPondorfVerley Reduction, LiAlH₄, NaBH₄, Diisobutylaluminiumhydride(DIBAL), Sodium cyanoborohydride, trialkyl borohydrides, Reduction with diimide, Wolff-Kishnerreduction.</p>	12
III	<p>Molecular Rearrangements</p> <p>Migration to electron deficient carbon atom. Pinacole-Pinacolone rearrangement, Wagner-Meerwein rearrangement, Dienone-Phenol rearrangement, Benzil-Benzilic acid rearrangement, Favorski rearrangement, ARNDT Eistert rearrangement, Sommelet – Hauser rearrangement.</p> <p>Migration to electron deficient hetero atom: Wolf, Hofmann, Curtius, Lossen, Schmidt, Beckmann rearrangement, Baeyer-Villiger rearrangement, Stevens, Neber rearrangements. Fries, Fischer-Hepp, Orton, Bamberger, Dakin, Cumene Hydroperoxide rearrangement.</p>	12
IV	<p>Pericyclic Reactions – I:</p> <p>Definition, classification of pericyclic reactions, Molecular Orbital energy level diagrams, electronic configuration in ground and first excited states of Ethylene, 1,3-Butadiene, 1,3,5 – Hexatriene, allyl system, stereo chemical notations – suprafacial, antarafacial, conrotatory and disrotatory modes, Woodward and Hoffmann selection rules.</p> <p>Electrocyclic reactions: Mechanism, Stereochemistry of (4n) and (4n+2) π systems. PMO, FMO and correlation methods.</p> <p>Cyclo additions: Mechanism, stereochemistry of (2+2) and (4+2) π systems, PMO, FMO and correlation methods.</p> <p>Sigmatropic rearrangements: Classification, mechanism for FMO and PMO approach under thermal and photo chemical conditions. (Detailed treatment of Claisen, Cope rearrangements fluxional molecules, aza-cope rearrangements).</p>	12
V	<p>Photochemistry:</p> <p>Photochemical processes: Energy transfer, sensitization and quenching. Singlet and triplet states and their reactivity. Photochemistry of olefins – conjugated olefins, Aromatic compounds – isomerisation – additions. Photochemistry of carbonyl compounds – Norrish type I and II reactions – Paterno – Buchi Reaction.</p> <p>Photoreduction, Photochemical rearrangements – Photo Fries rearrangement, Di-π-methane rearrangement, Barton reaction.</p>	12

Reference Books:

1. Molecular reactions and Photochemistry by Charles Dupey and O. Chapman, PrenticeHall.
2. Reaction mechanism in organic chemistry. 3rd edition, S.M.Mukherji&singh.
3. Advanced Organic Chemistry-Reactions, Mechanisms and Structure, Jerry March, John Wiley and sons, 6thedition.
4. Advanced Organic Chemistry, F.A. Carey and R.J Sundberg,Plenum.
5. Modern methods of organic synthesis, Cambridge University press, 3rd edition,W.Carruthers.
6. Organic Reaction Mechanisms, V.K.Ahluwalia, 4th edition,Narosa.
7. Reactions, rearrangements and reagents.S.N.Sanyal,4thedition.
8. Organic Photo chemistry and Pericyclic reactions' M.G.AroraAnmol Publications Pvt.Ltd.
9. Fundamentals of Photochemistry by K.K.Rohatgi–Mukherjee New Age internationalpublishers.

Course Focus: Employability &Entrepreneurship.

A.G. & S.G. SIDDHARTHA DEGREE COLLEGE OF ARTS & SCIENCE

Vuyyuru-521165.

NAAC recredited at 'A' level

Autonomous -ISO 9001 – 2015 Certified

Title of the Paper: ORGANIC SYNTHESIS

Semester: III

Course Code	20CH3T3A	Course Delivery Method	Class Room / Blended Mode - Both
Credits	4	CIA Marks	30
No. of Lecture Hours / Week	4	Semester End Exam Marks	70
Total Number of Lecture Hours	60	Total Marks	100
Year of Introduction :2020-21	Year of Offering: 2021 - 22	Year of Revision: -----	Percentage of Revision: 0%

Course Objective: The main objective of this paper is to give a basic and updated knowledge for the students on Formation of C-C single & double bonds, Diels-Alder and related reactions, Retro Synthetic Analysis and Protecting Groups.

Course Outcomes:

- CO1 :** Memorize the concepts, principles and theories related to formation of C – C single bond, C – C double bond, Diel's Alder related reactions. Protecting groups and disconnection approach in organic synthesis.
- CO2 :** Understand the role and significance of formation of C – C single bond, C – C double bond, Diel's Alder related reactions. Protecting groups and disconnection approach in organic synthesis.
- CO3 :** Apply the conceptual knowledge gained in formation of C – C single bond, C – C double bond, Diel's Alder related reactions. Protecting groups and disconnection approach in organic synthesis as and when required.
- CO4 :** Analyze the role of various reagents in carrying out the organic reactions like formation of C – C single bond, C – C double bond, Diel's Alder related reactions. Protecting groups and disconnection approach in organic synthesis.

Syllabus

Course Details

Unit	Learning Units	Lecture Hours
I	Formation of carbon-carbon single bonds: Alkylation of relatively acidic methylene groups, alkylation of ketones, enamine and related reactions, umplong (dipole inversion). Allylic alkylation of alkenes, alkylation of α -thiocarbanions- α - selenocarbanions, formation of carbon carbon single bonds by the addition of free radicals to alkenes, synthetic applications of carbenes and carbenoids.	12

II	<p>Formation of carbon-carbon double bonds</p> <p>Pyrolytic syn elimination reactions sulphoxide-sulphonate rearrangement, synthesis of allyl alcohols, the witting reaction, alkenes from sulphones, decarboxylation of β-lactones, alkenes from aryl sulphonyl hydrazones.</p> <p>Stereo selective synthesis of tri and tetra substituted alkenes, oxidative decarboxylation of carboxylic acids, stereospecific synthesis from 1,2-diols, reductive dimerization of carbonyl compounds.</p>	12
III	<p>Diels-Alder and related reactions: The dienophile, heterodienophile, oxygen as dienophile, The diene, acyclic dienes, heterodienes, 1,2-dimethylene cycloalkanes, vinyl cycloalkenes, and vinyl arenes, cyclic dienes and furans.</p> <p>Intra molecular Diels –Alder reactions, stereochemistry and mechanism of Diels – Alder reaction, retro Diels – Alder reaction, catalysis by lewis acids, photosensitized Diels- Alder reactions and 1,3-dipolar cycloaddition reactions, the ene reaction.</p>	12
IV	<p>Disconnection approach</p> <p>Introduction to Retro-synthetic analysis, Disconnection approach with suitable examples, Definitions: FGI, Disconnection, synthons, synthetic equivalent, reagent, target molecule, General strategy: choosing a disconnection, greatest simplification, symmetry, high yielding steps, recognizable starting materials.</p> <p>Chemo, regio and stereo selectivity with examples. One group C-C disconnections-Alcohols, carbonyl compounds, alkene synthesis, two group disconnections: 1,3 – dicarbonyl compounds, α,β – unsaturated carbonyl compounds.</p>	12
V	<p>Protecting groups:</p> <p>Theory and importance of functional group protection and deprotection in organic synthesis:-Protecting agents for the protection of functional groups: Hydroxyl group, Amino group, Carbonyl group and Carboxylic acid group</p> <p>carbon-carbon multiple bonds; chemo- and regioselective protection and deprotection. Illustration of protection and deprotection in organic synthesis.</p>	12

Reference Books:

1. Modern methods of Organic synthesis ,W. Carruthers Cambridge Press (3rdedition)
2. Principles of Organic synthesis by, ROC Norman, 3rd edition, CRCpress.
3. Modern Method of Organic Synthesis ,Carruthers and ColdhamSachinkumar Ghosh, Canbridge New Central Book Agency,1stedition.
4. Advances in Organic Reaction mechanism and structure, J. March, 6th edition, McGrewHill
5. Organic Synthesis: Ratnakumar, vol – II, NCBA Publications.

Course Focus: Employability & Entrepreneurshi

A.G.& S.G. SIDDHARTHA DEGREE COLLEGE OF ARTS & SCIENCE

Vuyyuru-521165.

NAAC reaccruited at 'A'level

Autonomous -ISO 9001 – 2015Certified

Title of the Paper: CHEMISTRY OF NATURAL PRODUCTS

Semester: III

Course Code	20CH3T4B	Course Delivery Method	Class Room / Blended Mode - Both
Credits	4	CIA Marks	30
No. of Lecture Hours / Week	4	Semester End Exam Marks	70
Total Number of Lecture Hours	60	Total Marks	100
Year of Introduction : 2020-2021	Year of Offering: 2021 - 22	Year of Revision: -----	Percentage of Revision: 0%

Course Objective: The main objective of this paper is to give a basic and updated knowledge for the students on Alkaloids, Terpenoids, Steroids, Flavonoids, Isoflavonoids and Plant pigments.

Course Outcomes:-

CO1 :Memorize the concepts related to Alkaloids, Terpenoids, Steroids, Flavonoids and Isoflavonoids andPigments.

CO2 :Understand the chemical role of Alkaloids, Terpenoids, Steroids, Flavonoids and Isoflavonoids andPigments.

CO3 :Execute the conceptual knowledge gained in the areas of Alkaloids, Terpenoids, Steroids, Flavonoids and Isoflavonoids and Pigments.

CO4 :Analyze the role of methods involved in structure elucidation of Alkaloids, Terpenoids, Steroids, Flavonoids and Isoflavonoids and Pigments.

Syllabus

Course Details

Unit	Learning Units	Lecture Hours
I	Alkaloids: Introduction, Definition, occurrence, role of alkaloids in plants, classification, isolation and general methods for structural elucidation of alkaloids. Structure elucidation of Morphine, Quinine.	12
II	Terpenoids: Introduction, Definition, nomenclature, classification, isolation, isoprene rule and general methods for structural elucidation of Terpenoids. Structure elucidation of Zingiberene, farnesol.	12
III	Steroids: Introduction, Definition, nomenclature, classification. Occurrence, isolation, physiological action, structure elucidation of Androsterone, Progesterone.	12
IV	Flavonoids and Isoflavonoids: Introduction, Definition, classification, isolation, physiological action, structure elucidation of Kaempferol and Quercetin.	12
V	Pigments: Introduction, classification of natural pigments, introduction and classification of carotenoids, functions of carotenoids in plants and animals, structure and synthesis of α – carotene and β – carotene.	12

Reference Books:

1. Organic Chemistry, Vol:2, I.L.Finar, 5th Edition.
2. Chemistry of Natural Products, K.W. Bentley, Oxford at the Clarendon Press, 1st edition.
3. Chemistry of Natural Products by P.S. Kalsi Kalyani Publishers, 1983, low cost university edition.
4. Chemistry and physiology of alkaloids by Manske Vol. I & II, VII, Academic Press Inc., publishers New York, 1st edition.

Course Focus: Employability & Entrepreneurship.

A.G. & S.G. SIDDHARTHA DEGREE COLLEGE OF ARTS & SCIENCE

Vuyyru-521165 NAAC

reaccredited at 'A' level

Autonomous -ISO 9001 – 2015 Certified

Title of the Paper: POLYMER CHEMISTRY

Semester: III

Course Code	20OECH	Course Delivery Method	Class Room / Blended Mode - Both
Credits	4	CIA Marks	30
No. of Lecture Hours / Week	4	Semester End Exam Marks	70
Total Number of Lecture Hours	60	Total Marks	100
Year of Introduction : 2021 - 22	Year of Offering: 2021 - 22	Year of Revision: ----	Percentage of Revision: ----

Course Objective: The main objective of this paper is to give a basic and updated knowledge for the students on Polymer chemistry.

Course Outcomes:

CO1 : Memorize the concepts related to polymer chemistry

CO2 : Understand the concepts of polymer chemistry

CO3 : Apply the knowledge gained in polymer chemistry in chosen job role.

Syllabus

Course Details

Unit	Learning Units	Lecture Hours
I	Introduction, Classification of polymers, Polymerization, chain polymerization, step polymerization, Co polymerization, Free radical chain polymerization, cationic polymerization, anionic polymerization, Polymerization Techniques, Graft and Block Copolymers.	12
II	Polymer Synthesis, Isolation and Purification of polymers, Polymer Fractionation, Molecular weight determination, Molecular weight determination curve, Processing Techniques.	12
III	Polymer Reactions—Introduction, Hydrolysis, Acidolysis, Aminolysis, Hydrogenation, Addition and Substitution Reactions, Cyclisation reactions, Cross-linking Reactions.	12

IV	Polymer Degradation – Definition, Types of Degradation, Thermal Degradation, Mechanical Degradation, Degradation by Ultrasonic Waves, Photodegradation, Degradation by High-Energy Radiation, Oxidative Degradation, Hydrolytic Degradation.	12
V	Plastics, Fibres, Elastomers-Polyethylene, Polystyrene, PolyEsters, PolyAcrylonitrile, Polyurethanes, Polyvinyl Chloride, Polyisoprenes. Resins–Phenol Formaldehyde Resin, Urea Formaldehyde and Melamine–Formaldehyde Resins,Epoxy Polymers, Silicon Polymers.	12

Reference Books:

1. Textbook of Polymer Science byFrod,W.Billmayer,
2. An Introduction to Polymer Chemistry byMoore.
3. Polymer Chemistry-An Introduction byM.P.Stevens.
4. Polymer Science –VRGowariker, NVViswanathan,JayadevSreedhar.

Course Focus : Employability .

A.G.& S.G. SIDDHARTHA DEGREE COLLEGE OF ARTS & SCIENCE

Vuyyuru-521165.

NAAC recredited at 'A' level

Autonomous -ISO 9001 – 2015 Certified

Title of the Paper: ORGANIC PREPARATIONS

Semester: III

Course Code	20CH3L1	Course Delivery Method	Class Room / Blended Mode - Both
Credits	4	CIA Marks	30
No. of Lecture Hours / Week	4	Semester End Exam Marks	70
Total Number of Lecture Hours	60	Total Marks	100
Year of Introduction :2020-21	Year of Offering: 2021 - 22	Year of Revision: -----	Percentage of Revision:0%

Course Objective: The main objective of this paper is to give a basic and updated knowledge for the students on organic chemistry practical.

Course Outcomes:-

CO1: Memorize the principle involved in various organic preparations.

CO2: Understand the mechanism involved in organic preparation.

CO3: Apply the knowledge of organic preparations in their chosen field.

Syllabus

Course Details:-

1. Preparation of organic compounds: Three stage preparations by reactions involving nitration, halogenation, oxidation, reduction, alkylation, acylation, condensation and rearrangement. (A student is expected to prepare at least five different organic compounds by making use of the reactions given above).
2. Green Procedures for organic compound preparations (atleast 5preparations).

Course Focus: Skill Development & Employability

A.G.& S.G. SIDDHARTHA DEGREE COLLEGE OF ARTS & SCIENCE

Vuyyuru- 521165.

NAAC reaccredited at 'A' level

Autonomous -ISO 9001 – 2015 Certified

Title of the Paper: Mixture Analysis

Semester: III

Course Code	20CH3L2	Course Delivery Method	Class Room / Blended Mode - Both
Credits	4	CIA Marks	30
No. of Lecture Hours / Week	4	Semester End Exam Marks	70
Total Number of Lecture Hours	60	Total Marks	100
Year of Introduction :2020-21	Year of Offering: 2021 - 22	Year of Revision: -----	Percentage of Revision: 0 %

Course Objective: The main objective of this paper is to give a basic and updated knowledge for the students on Analysis of organic binary mixtures.

Course Outcomes:-

CO1 :Get familiarized with the tests involved to identification of various functional groups.

CO2 :Understand the theory involved in identification and separation of the given organic mixture based on the solubility

CO3 :Apply the knowledge to identify various functional groups present in the given organic compound by using a systematic procedure.

Syllabus

Course Details:-

Analysis of organic binary mixtures: Separation and identification of organic binary mixtures (The students must be given training in at least 10 mixtures with different functional groups).

Note: For semester end examinations the student has to submit at least two solid derivatives for each individual component.

Course Focus: Skill Development & Employability

**M.Sc. DEGREE EXAMINATION
THIRD SEMESTER
Paper-I:: ADVANCED ORGANIC SPECTROSCOPY**

Time:3hours

Maximum Marks:70

SECTION – A

Answer all the questions. Each question carries 2 marks. (10x2M=20M)

1. a) Explain the importance of Double irradiation. (CO-1)
- b) Write a short note on nomenclature of spin systems. (CO-1)
- c) Explain the α , β & γ effects in ^{13}C NMR with suitable examples. (CO-1)
- d) Discuss the importance of off resonance decoupling CMR spectrum. (CO-1)
- e) What is Cotton effect? (CO-1)
- f) Predict the sign of cotton effect in 3-methyl cyclohexanone when substituent is in equatorial position. (CO-1)
- g) What information is possible from the COSY experiment? (CO-2)
- h) Discuss about various periods involved in 2D NMR. (CO-1)
- i) Discuss briefly the IR signals for the compound $\text{C}_6\text{H}_5 - \text{CH}_2 - \text{O} - \text{CO} - \text{CH}_3$. (CO-2)
- j) Predict the possible number of ^1H NMR signals for the compound $\text{CH}_3 - (\text{CO}) - \text{CH}_2 - \text{CH}_3$. (CO-2)

SECTION – B

(10x5=50M)

UNIT - I

2. a) Explain the effect of solvent on PMR spectrum. (CO-2)
- (Or)**
- b) Differentiate between first order and non first order PMR spectrum with examples. (CO-2)

UNIT – II

3. a) Discuss the importance of BBD & SFORD techniques in ^{13}C NMR spectroscopy. (CO-2)
- (Or)**
- b) A compound of MF C_4H_{10} in its CMR Spectrum show 17.1(q) 67.4(T). Determine the structure of compound by using CMR data. (CO-2)

UNIT – III

4. a) Explain the following i) Axial halo ketone rule ii) Types of optical rotatory dispersion curves. (CO-1)
- (Or)**
- b) Explain the applications of Octant rule. (CO-2)

UNIT – IV

5. a) What information about a compound can be obtained from the 2D INADEQUATE experiment? (CO-2)
- b) Discuss the importance of NOESY technique with suitable example. (CO-2)

UNIT – V

6. a) Deduce the structure of the compound consistent with the following data elemental analysis:
C=32.14% H 5.35% and Cl 62.5% UV: No absorption above 210 nm, IR (CCl_4) 2941, 2265 and 1460 cm^{-1} PMR δ 2.72(septet, $J=6.7$, 1H), 1.33(doublet, $J=6.7$, 6H) (CO-3)
- (Or)**
- b) Deduce the structure of the compound consistent with the following data elemental analysis:
C=32.14% H 5.35% and Cl 62.5% UV: No absorption above 210 nm IR (CCl_4) 2940, 1265 and 690 cm^{-1} and PMR δ 3.5(2H, D), 3.3(1H, m) and 1.25(3H, d) (CO-3)

**M.Sc. DEGREE EXAMINATION
THIRD SEMESTER
Paper-II:: ORGANIC REACTIONS & MECHANISMS**

Time:3hours

Maximum Marks:70

SECTION – A

Answer all the questions. Each question carries 2 marks. (10x2M=20M)

1. a) Discuss oxidations with HIO_4 . (CO-2)
- b) Define oxidation and discuss the various types of oxidations. (CO-1)
- c) Write notes on reduction with diimide. (CO-1)
- d) Give the definition and mechanism of Clemmensen's reduction. (CO-2)
- e) Discuss Dienone phenol rearrangement. (CO-1)
- f) Write an account of Wolff rearrangement. (CO-2)
- g) What are pericyclic reactions? Give the classification. (CO-1)
- h) Write the molecular orbital energy level diagram for 1,3-Butadiene. (CO-2)
- i) Write notes on energy transfer. (CO-1)
- j) Explain Barton reaction. (CO-2)

SECTION-B

(5x10M=50M)

UNIT - I

2. a) Explain oxidations with i) RuO_4 ii) SeO_2 (CO-3)
- (Or)**
- b) Explain oxidations with i) KMnO_4 ii) MnO_2 (CO-3)

UNIT – II

3. a) Discuss Birch reduction of aromatic compounds. (CO-2)
- (Or)**
- b) Discuss the reductions with LiAlH_4 . (CO-2)

UNIT – III

- 4 a) Explain the following
 - i) Wagner Meerwein rearrangement ii) Benzil – Benzilic acid rearrangement. (CO-2)
 - (Or)**
 - i) Baeyer Villiger rearrangement ii) Cumene hydroperoxide rearrangement. (CO-2)

UNIT - IV

5. a) Apply correlation method to $4n\pi$ electrocyclic reaction for thermal and photochemical conditions. (CO-3)
- (Or)**
- b) Apply FMO method to 1,5 sigmatropic shift and write Woodward and Hoffmann rules by PMO method. (CO-3)

UNIT - V

- 6 a) Discuss Norrish type – I and type – II reactions. (CO-2)
- (Or)**
- b) Explain the following i) photochemistry of olefins ii) Di – π – methane rearrangement. (CO-2)

**M.Sc. DEGREE EXAMINATION
THIRD SEMESTER
Paper-III:: ORGANIC SYNTHESIS**

Time:3hours

Maximum Marks:70

SECTION – A

Answer all the questions. Each question carries 2 marks.

(10x2M=20M)

1. a) What are acidic methylene groups? (CO-2)
- b) Explain about carbenes. (CO-1)
- c) Discuss in short about syn elimination. (CO-1)
- d) Elaborate Wittig reaction with an example. (CO-2)
- e) Describe dienophile with an example. (CO-1)
- f) What are Lewis acids? Explain with an example. (CO-2)
- g) Enumerate the significance of Disconnection approach in organic synthesis. (CO-2)
- h) Write a short note on synthon. (CO-1)
- i) Discuss the role of functional group protection & deprotection in organic synthesis. (CO-2)
- j) Explain the importance of regioselective protection. (CO-2)

SECTION – B

(5x10M=50M)

UNIT - I

2. a) Explain enamine and related reactions. (CO-2)
- (Or)**
- b) Discuss in detail the synthetic applications of carbenes and carbenoids with examples. (CO-2)

UNIT – II

3. a) Write an account of reductive dimerisation of carbonyl compounds with examples. (CO-2)
- (Or)**
- b) Discuss any three methods for the stereoselective synthesis of tri and tetra substituted alkenes. (CO-2)

UNIT – III

4. a) What is Diels Alder reaction? Discuss the mechanism and stereochemistry. (CO-2)
- (Or)**
- b) Write note on 1,3 – dipolar cycloaddition reactions. (CO-2)

UNIT - IV

5. a) Discuss the various methods of disconnection of alcohols. (CO-3)
- (Or)**
- b) Give an account of disconnections of 1,3 – dicarbonyl compounds. (CO-2)

UNIT – V

6. a) Discuss about the protecting agents to protect the following functional groups (CO-3)
- (i) AMINO group (ii) carboxylic acid.
- (Or)**
- b) List out the reagents and apply them for the protection and deprotection of hydroxyl and carbonyl groups. (CO-3)

**M.Sc. DEGREE EXAMINATION
THIRD SEMESTER
Paper-IV:: CHEMISTRY OF NATURAL PRODUCTS**

Time:3hours

Maximum Marks:70

SECTION – A

Answer all the questions. Each question carries 2 marks.

(10x2M=20M)

1. a) What are alkaloids? Explain. (CO-2)
- b) Discuss the general classification of alkaloids. (CO-1)
- c) Discuss isoprene rule. (CO-1)
- d) Write the structure of Zingiberine. (CO-2)
- e) Write the synthesis of farnesol. (CO-2)
- f) Discuss the nomenclature of steroids. (CO-1)
- g) Give a short note on classification of flavonoids? (CO-1)
- h) Discuss the isolation of flavonoids and isoflavonoids. (CO-2)
- i) Discuss the classification of natural pigments. (CO-1)
- j) Discuss the functions of carotenoids in plants. (CO-2)

SECTION – B

(10x5=50M)

UNIT - I

2. a) Outline the synthesis of Morphine. (CO-2)
- (Or)**
- b) Discuss the structure elucidation of Quinine. (CO-3)

UNIT – II

3. a) Explain the structure elucidation of santonin. (CO-2)
- (Or)**
- b) Write notes on structure elucidation of abietic acid. (CO-2)

UNIT – III

4. a) Establish the structure of nucleus and size of the rings A, B, C and D in cholesterol. (CO-3)
- (Or)**
- b) Establish the structure of progesterone and write any one method of synthesis. (CO-3)

UNIT - IV

5. a) Write structure elucidation of kaempferol. (CO-3)
- (Or)**
- b) Write structure elucidation of Quercetin. (CO-3)

UNIT - V

6. a) Discuss the structure elucidation of α -carotene. (CO-3)
- (Or)**
- b) Discuss the structure elucidation of β -carotene. (CO-3)

M.Sc.
DEGREE EXAMINATION
THIRD SEMESTER
POLYMER CHEMISTRY

Time: 3 hours

Maximum Marks: 70

SECTION – A

Answer all the questions. Each question carries 2 marks. (10x2M=20M)

1. a) Discuss about classification of polymers. (CO-1)
- b) Explain one polymerization reaction which involves free radical mechanism. (CO-2)
- c) Give a short account on isolation of polymers. (CO-1)
- d) Describe the purification method of polymers. (CO-1)
- e) What is hydrolysis? Explain with an example. (CO-2)
- f) What is cross – linking reaction? Explain its impact. (CO-2)
- g) List out the types of degradation methods. (CO-1)
- h) Explain ultrasonic waves degradation with an example. (CO-2)
- i) What are elastomers? Explain in brief. (CO-2)
- j) Discuss the method for the synthesis of polystyrene. (CO-2)

SECTION – B

(10x5=50M)

UNIT - I

2. a) Explain in detail about cationic polymerization with suitable examples. (CO-2)
- (Or)**
- b) Give a detailed account on Graft and Block copolymers. (CO-2)

UNIT – II

3. a) Discuss in detail about molecular weight determination. (CO-2)
- (Or)**
- b) Explain elaborately about various processing techniques. (CO-2)

UNIT – III

4. a) Illustrate the following with suitable examples (i) Aminolysis (ii) Cyclisation reactions. (CO-2)
- (Or)**
- b) Write an account on addition & substitution reactions with suitable examples. (CO-2)

UNIT – IV

5. a) Describe the following degradation methods with suitable examples
 (i) Thermal degradation (ii) Photodegradation (CO-2)
- b) Discuss the significance of oxidative degradation and hydrolytic degradation. (CO-2)

UNIT – V

6. a) Give an account on the following (i) Polyacrylonitrile (ii) Polyurethanes (CO-2)
- (Or)**
- b) Elaborate the following in detail (i) Epoxy polymers (ii) Silicon polymers (CO-2)

**AG & SG SIDDHARTHA DEGREE COLLEGE OF ARTS &
SCIENCE(AUTONOMOUS)VUYYURU-521165**
Aided by the Government of A.P, Re-Accredited by NAAC with 'A' Grade

2021-2022





PG Department of Chemistry

26-03-2022

MINUTES OF BOARD OF STUDIES

Minutes of meeting of Board of studies in PG Department of Chemistry held on 26-03-2022 at 12.00 pm in the PG Department of Chemistry through online (Zoom meeting)

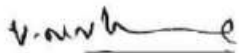
Members Present

S.No	NAME		Signature
1	Dr. V.Sreeram Head, Dept. of Chemistry(P.G) AG & SG S College, Vuyyuru.	Chairman	
2	Prof.C.Suresh Reddy Department of Chemistry S.V. University, Tirupati.	University Nominee	
3	Prof. Koya Prabakar Rao Department of Chemistry Vignan University, Guntur.	Subject Expert	
4	Dr.M.Sivanath Associate prof. Dept. of Chemistry A.N.R.College, Gudivada.	Subject Expert	
5	Dr.G.Raja Manager(Q.A) Biophore India pharamaceuticals. Hyderabad.	Representative from Industry	
6	Abdul Raheem	One Post Graduate Meritorious Aluminous nominated by the Principal	
7	N.V.Srinivasa Rao Department of Mathematics AG & SG S College, Vuyyuru.	Representative Science Faculty Other Dept.	
8	V.N.V.Kishore Dept. of Chemistry(P.G) AG & SG S College, Vuyyuru	Member	
9	Dilshad Begum Dept. of Chemistry(P.G) AG & SG S College, Vuyyuru	Member	
10	M.Rekha Dept. of Chemistry(P.G) AG & SG S College, Vuyyuru	Member	

**A.G. & S.G. SIDDHARTHA DEGREE COLLEGE OF ARTS &
SCIENCE (Autonomous)
DEPARTMENT OF CHEMISTRY
M.Sc – CHEMISTRY (ORGANIC CHEMISTRY)
II SEMESTER**

Paper Code & Title: 20CH2T1: ORGANIC SPECTROSCOPY

No. of hours per week: 04 Total credits: 04

Total marks: 100 (Internal: 30 M & External: 70M)

Course: Organic Spectroscopy (code 20CH2T1)		
S.No	COURSE OUTCOMES	PO'S
	The graduate will be able to	
1	Memorize the basic principles and theory involved in molecular absorption spectroscopy.	2,7
2	Comprehend the advanced concepts of molecular absorption spectroscopy.	1,2,5
3	Apply the knowledge of spectroscopy in establishing the structure of organic molecules.	1,5,7
4	Analyze the spectral data to ascertain the structure of unknown molecules.	1,4,2

UNIT- I

UV- Visible Spectroscopy:

Mechanics of measurement – Energy transitions – Simple chromophores – Auxochrome, Absorption shifts (Bathochromic shifts, Hypsochromic shift, Hyper chromic shift, Hypochromic shift). UV absorption of Alkenes – polyenes, unsaturated cyclic systems .

UV absorption of Carbonyl compounds α,β -unsaturated carbonyl systems - UV absorption aromatic systems – solvent effects – geometrical isomerism – acid and base effects – typical examples – calculation of λ_{max} values for simple molecules using Woodward -Fieser rules

AGENDA:

1. To prepare syllabus and model question papers, discuss & approve modalities of lab courses.
2. To Suggest methodologies for innovative methods of teaching.
3. Any other matter with the permission of the Chair.

Resolution –I

1. Resolved to recommend the framed Syllabus & Model Question Papers for theory courses and approve the modalities of Lab Courses as prescribed by BOS members.
2. Resolved to conduct assignments etc., for Internal Assessment Tests.
3. To recommend the changed syllabus Radioactivity and isotopes in Unit V of semester I

Resolution –II

1. Resolved to adopt online teaching methods like as ZOOM, Microsoft teams, Google meet etc for ICT (Information and communication technologies) teaching.

Resolution –III

1. Resolved to implement changed syllabus in II& IV Semesters

V. G. W.

UNIT – II

IR Spectroscopy:

Mechanics of measurement – Fundamental modes of vibrations -Stretching and bending vibrations – Factors effecting vibrational frequency-hydrogen bonding.

Finger print region and its importance. Typical group frequencies for – CH,

-OH, -NH, -CC, -CO and aromatic systems - Application in structural determination

Examples – simple problems.

UNIT – III

Nuclear Magnetic Resonance Spectroscopy (1HNMR – First Order PMR):

Introduction:Nuclear spin-Basic principle of -NMR - nuclear resonance –saturation-Larmor's frequency-Relaxation- Instrumentation(Cw and FT) shielding and de shielding of magnetic nuclei- chemical shift and its measurements, factors influencing chemical shift, spin-spin interactions and factors influencing spin -spin coupling- Dynamic NMR- coupling constant J. and factors effecting J value.

UNIT – IV

Mass Spectrometry I

Introduction- ionization methods-EI, CI, ES, MALDI and FAB – advantages and disadvantages-molecular ion peak and its importance, meta stable peak, Nitrogen rule and extension of nitrogen rule. Determination of Molecular weight and determination of molecular formulae- Isotopic Peaks- Identification of single chlorine atom and double chlorine atom single bromine atom and double bromine atoms in organic compounds. Instrumentation.

UNIT – V

Mass Spectrometry II

Fundamental fragmentation process- Stevenson's rule- radical site initiated cleavage-charge site initiated cleavage- two bond cleavage- Retrodielalder cleavage- Mc-Lafferty rearrangement and other cleavages. Mass spectral fragmentation of alkanes, cycloalkanes, alkenes, alkynes, aromatic hydrocarbons, alcohols, phenols, thiols, ethers, carbonyl containing compounds (Aldehydes, ketones, esters and carboxylic acids), nitrogen compounds, alkyl chlorides and alkyl bromides, Examples of mass spectral fragmentation of organic compounds with respect to their structure determination.

Text books/ Reference books:

1. Introduction to Spectroscopy – D. L. Pavia, G.M. Lampman, G. S. Kriz, 3rd Ed. (Harcourt college publishers).
2. Spectrometric identification of organic compounds R. M. Silverstein, F. X. Webster, 6th Ed.
John Wiley and Sons.
3. Spectroscopic methods in organic chemistry - D. H. Williams and I. FlemmingMc.Graw Hill.
4. Absorption spectroscopy of organic molecules – V. M. Parikh
5. Nuclear Magnetic Resonance – Basic Principles- Atta-Ur-Rehman, Springer-Verlag (1986).
6. One- and Two-dimensional NMR Spectroscopy – Atta-Ur-Rehman, Elsevier (1989).
7. Organic structure Analysis- Phillip Crews, Rodriguez, Jaspars, Oxford University Press (1998).
8. Organic structural Spectroscopy- Joseph B. Lambert, Shurvell, Lightner, Cooks, Prentice-Hall (1998).
9. Organic structures from spectra –Field L.D., Kalman J.R. and Sternhell S. 4th Ed. John Wiley and sons Ltd.

NOTE:PercentageofChange - 0%

**A.G. & S.G. SIDDHARTHA DEGREE COLLEGE OF ARTS &
SCIENCE (Autonomous)
DEPARTMENT OF CHEMISTRY
M.Sc – CHEMISTRY (ORGANIC CHEMISTRY)
II SEMESTER**

Paper Code & Title: 20CH2T2: INORGANIC CHEMISTRY-II

No. of hours per week: 04 Total credits: 04

Total marks: 100 (Internal: 30 M & External: 70M)

Course: Inorganic chemistry (code 20CH2T2)		
S.No	COURSE OUTCOMES	PO'S
	The graduate will be able to	
1	Memorize the fundamental concepts of Metallic & non metallic clusters, Inorganic reaction mechanisms, organo metallic chemistry, electronic spectra & magnetic properties of complexes and bioinorganic chemistry.	2,7
2	Comprehend the basic and advanced concepts of metallic & non metallic clusters, Inorganic reaction mechanisms, organo metallic chemistry, electronic & magnetic properties of complexes and bioinorganic chemistry.	1,2,6
3	Apply the conceptual knowledge gained in the concepts of metallic & nonmetallic clusters, inorganic reaction mechanisms, organometallic chemistry, electronic & magnetic properties of complexes and bio inorganic chemistry in other fields of chemistry as well as in research.	1,2,7
4	Analyze the role of metallic & non metallic clusters / cages, inorganic reaction mechanisms, organo metallic chemistry, electronic & magnetic properties of complexes and bio inorganic chemistry in understanding the similarities and differences among the concepts of chemistry.	1,3,2
5	Assess that how far the concepts of metallic & non metallic clusters, Inorganic reaction mechanisms, organo metallic chemistry, electronic & magnetic properties of complexes and bioinorganic chemistry are useful in rendering theoretical explanations for the concepts in chemistry.	1,7,2

Unit-I: Non-metal cages and metal clusters:

Structure and bonding in phosphorous-oxygen, phosphorous-Sulphur cages; structure and bonding in higher boranes with (special reference to B₁₂icosahedra). Carboranes, metalloboranes, metallocarboranes. Classification- LNCs and HNCs, Isoelectronic and Isolobal relationships, electron counting rules: Wade's and Lauher's rules. M-M multiple bonding; preparation, structure and bonding in dinuclear [Re₂Cl₈]²⁻ ion, trinuclear [Re₃Cl₉], tetra nuclear W₄(OR)₁₆, hexa nuclear [Mo₆Cl₈]⁴⁺ and [Nb₆Cl₁₂]²⁻.

Unit-II: Organometallic chemistry of transition metals:

Classification and electron counting rules, hapticity, synthesis, structure and bonding of Olefinic complexes, Acetylene complexes, ferrocene, dibenzene chromium, cyclo heptatriene and tropylium complexes of transition metals. Reactions of organometallic compounds - oxidative addition reductive elimination, insertion and elimination. Applications of organometallic compounds, Catalytic hydrogenation, Hydroformylation, alkene polymerization.

Unit-III: Reaction mechanism of transition metal complexes:

Kinetics of octahedral substitution, acid hydrolysis, base hydrolysis-conjugate base (CB) mechanism. Direct and indirect evidences in favour of CB mechanism. Anation reactions. Reactions without metal-ligand bond cleavage. Factors affecting the substitution reactions in octahedral complexes. Trans effect on substitution reactions in square planar complexes. Mechanism of redox reactions, outer sphere mechanism, cross reactions and Marcus-Hush equation, inner sphere mechanism.

Unit-IV: Term symbols and Electronic spectra: Term symbols:

Term symbols and their derivation, Microstates, Hund's rules to predict ground terms and ground states. List of ground energy and higher energy terms from d₁ to d₉ configurations;

Electronic spectra of transition metal complexes:

Spectroscopic terms. Selection rules, Slater-Condon parameters, Racah parameters, Term separation energies for d_n configurations, Orgel diagrams. Tanabe-Sugano diagrams for d₁ to d₉ configurations. Calculations of D_q, B and β parameters. Charge transfer spectra.

Unit-V: Bio-inorganic chemistry and Magnetic properties of complexes:

Storage and transport of dioxygen by Hemoglobin and Myoglobin, Vitamin B₁₂ and its importance.

Magnetic properties of transition metal complexes:

Types of magnetism, factors affecting Paramagnetism, anomalous magnetic moments - Orbital and spin contribution, spin-orbit coupling and magnetic moments chiro optical properties, Cotton effect and Faraday effect.

Text books/ Reference books:

1. Inorganic Chemistry by Huheey. Harper and Row.
2. Concise inorganic chemistry by J. D. Lee, ELBS.
3. Inorganic chemistry, K.F. Purcell and J.C. Kotz, Holt Saunders international
4. Organometallic chemistry by R.C. Mehrotra and A. Singh. New Age International.
5. Advanced Inorganic Chemistry by Cotton and Wilkinson, Wiley Eastern
6. Inorganic reaction mechanism by Basolo and Pearson, Wiley Eastern
7. Bioinorganic Chemistry by K. Hussan Reddy
8. Biological Aspects of inorganic chemistry by A. W. Addison, W. R. Cullen, D. Dolphin and G. J. James. Wiley Interscience.
9. Photochemistry of coordination compounds by V. Balzani and V. Carassiti. Academic Press.
10. Text book of Coordination chemistry by K. Soma Sekhara Rao and K.N.K. Vani, Kalyani Publishers.

NOTE: Percentage of Change - 0%

**A.G.& S.G.SIDDHARTHA DEGREE COLLEGE OF ARTS &
SCIENCE(Autonomous)
DEPARTMENT OF CHEMISTRY
M.Sc – CHEMISTRY (ORGANIC CHEMISTRY)
II SEMESTER**

Paper Code & Title: 20CH2T3: ORGANIC CHEMISTRY -II

No. of hours per week: 04

Total credits: 04

Total marks: 100

(Internal: 30 M & External:

70M)

Course: Organic chemistry (code 20CH2T3)		
S. No	COURSE OUTCOMES	PO'S
	The student will be able to	
1	Understand the basic and advanced concepts of stereochemistry, conformational analysis, green chemistry, nanochemistry and named reactions.	2,7
2	Apply the concepts related to stereochemistry, conformational analysis, green and nano chemistry in establishing the mechanism of the reaction.	1,2,3
3	Assess that how far the knowledge gained in stereochemistry, green chemistry and nanochemistry is useful in understanding the nature of product.	1,5,6
4	Evaluate the role of stereochemistry, green principles and nano chemistry in establishing the mechanism of a reaction as well as in other areas of chemistry.	1,4,7

Unit-I: Named reactions:

Aldol condensation, Benzoin condensation, Cannizzaro condensation, claisen condensation, Dieckmann condensation, Perkin condensation, Stobbe condensation, Reformatsky reaction, Mannich reaction, Reimer-Tiemann reaction, Vilsmeier-Haack reaction, Shapiro

reaction, McMurray reaction, Michael addition reaction, Wittig reaction, Stork – Enamine reaction, Acyloin condensation, Robinson ringannulation and Simmon-Smith reaction.

Unit-II: Stereo Chemistry-I:

Concept of chirality, Recognition of Symmetry elements. Definition and classification of Stereoisomers, Enantiomer, Diastereomer, Homomer, Epimer, Anomer, Configuration and Conformation, Configurational nomenclature: D,L and R, S nomenclature. Molecular representation of organic molecules: Fischer, Newman and Sawhorse projections and their inter-conversions. Geometrical Isomerism. Cis-trans, E, Z- and Syn and anti nomenclature, Methods of determining configuration of Geometrical isomers using physical, spectral and chemical methods.

Unit-III: Stereo Chemistry-II:

Definition of Conformation, Conformational analysis of acyclic molecules – alkanes and substituted alkanes. Conformational analysis of monocyclic molecules – cyclohexane – chair, boat and twist boat - mono and disubstituted cyclohexanes and conformation around carbon hetero atom bonds having C–O & C–N. Confirmation and intramolecular hydrogen bonding.

Unit-IV: Green chemistry & Phase transfer catalysis:

Introduction to Green chemistry, Principles and concepts of Green chemistry, Green Catalysis, Biocatalysis, renewable resources, Green Reagents, examples of green reactions- synthesis of Ibuprofen, Clean Fischer-Indole synthesis comparison of the above with conventional methods. Introduction to Microwave organic synthesis: introduction, advantages and disadvantages. Applications: solvents (water and organic solvents), solvent free reactions (Solid state reactions).

Unit-V: Chemistry of Nanomaterials:

Introduction, carbon nanotubes: structure of single and multi-walled carbon nanotubes, synthesis-solid and gaseous carbon source-based production techniques, synthesis with controlled orientation. Growth mechanism of carbon nano tubes-catalyst free growth, catalyst activated growth, general properties and applications.

Text books:

1. Advanced organic chemistry –Reaction, mechanism and structure, Jerry March, John Wiley.
2. A guide book to Mechanism in organic chemistry, Peter Sykes, Longman.
3. Organic chemistry, I.L. Finar, Vol. I & II, Fifth ed. ELBS, 1975.
4. Stereo Chemistry of carbon compounds – E.L. Eliel.
5. Nano, The Essentials: T. Pradeep, The Mc. Graw Hill & Co.
6. Principles of organic synthesis, R.O.C. Norman and J.M. Coxon, Blakie Academic & Professional.
7. Reaction Mechanism in organic chemistry, S.M. Mukherji and S.P. Singh, Macmillan.
8. Green chemistry Theory and Practice by Paul T. Anastas and John C. Warner, Oxford University press.
9. Methods and reagents for Green chemistry, PietroTundo, AlvisePerosa, FulvioZecchini, John Willey& sons Inc.

NOTE:PercentageofChange - 0%

**A.G.& S.G.SIDDHARTHA DEGREE COLLEGE OF ARTS &
SCIENCE(Autonomous)
DEPARTMENT OF CHEMISTRY
M.Sc – CHEMISTRY (ORGANIC CHEMISTRY)
II SEMESTER**

Paper Code & Title: 20CH2T4: PHYSICAL CHEMISTRY-II

No. of hours per week: 04 Total credits: 04

Total marks: 100 (Internal: 30 M & External: 70M)

Course: Physical chemistry (code 20CH2T4)		
S.No	COURSE OUTCOMES	PO'S
	The student will be able to	
1	Remember the concepts of thermodynamics, polymer chemistry, electro chemistry, chemical kinetics, photo chemistry.	1,2,7
2	Understand the concepts of thermodynamics, polymer chemistry, electro chemistry, chemical kinetics, photo chemistry.	1,2,7
3	Apply the concepts of thermodynamics, polymer chemistry, electro chemistry, chemical kinetics, photo chemistry in research and other allied fields.	1,2,4
4	Analyze the role and significance of concepts of thermodynamics, polymer chemistry, electro chemistry, chemical kinetics, photo chemistry.	1,2,7
5	Evaluate the role of concepts of Radio activity and isotopes in chemistry and applications of radio isotopes in industry and medicine	1,2,7

Unit-I: Third law of Thermodynamics and Statistical thermodynamics:

Nernst Heat theorem -Third law of thermodynamics - Its limitations - Determination of absolute entropy -

Thermodynamic probability and most probable distribution, Entropy and probability - Boltzmann-Plank equation. Ensembles, Maxwell-Boltzmann distribution, Fermi-Dirac statistics,

Bose Einstein statistics. Partition function - calculation of thermodynamic properties in terms of partition function - Chemical equilibrium and partition function - Translational, rotational and electronic partition function - Entropy of Monoatomic gases (Sackur-Tetrode equation).

Unit-II: Polymer chemistry and Raman Spectroscopy:

Classification of polymers - Free radical, ionic and Zeigler -Natta Polymerization - kinetics of free radical polymerization - Techniques of polymerization - Glass transition temperature - Factors influencing the glass transition temperature. Number average and Weight average, Molecular weights - molecular weights determinations - Membrane Osmometry, Light scattering phenomenon. Classical and quantum theories of Raman effects, pure rotational, vibrational and Vibrational-rotational Raman spectra, selection rules, mutual exclusion principle.

Unit-III: Electro Chemistry-II:

Reference electrode - Standard hydrogen electrode. Calomel electrode - Indicator electrodes: Metal-metal ion electrodes - Inert electrodes - Membrane electrodes- theory of glass membrane potential, potentiometric titrations, advantages of potentiometric titrations, Conductometric titrations. Electrode potentials - Double layer at the interface - rate of charge transfer - Decomposition potential - Over potential - Tafel plots - Derivation of Butler-Volmer equation for one electron transfer - electro chemical potential

Unit-IV: Chemical kinetics and Photo chemistry:

Branching Chain Reactions - Hydrogen-oxygen reaction - lower and upper explosion limits - Fast reactions - Study of kinetics by flow methods - Relaxation methods - Flash photolysis. Acid base catalysis - protolytic and prototropic mechanism. Enzyme catalysis - Michaelis-Menten kinetics.

Photochemistry:

Quantum yield and its determination, Actinometry, Reactions with low and high quantum yields, Photo sensitization, Exciplexes and Excimers, Photochemical equilibrium, Kinetics of collisional quenching - Stern-Volmer equation.

Unit-V:

Radioactivity and Isotopes: Introduction to radioactivity, properties of alpha rays, beta rays and gamma rays, theory of radioactive disintegration, rate of disintegration, Geiger – Nuttall rule, radioactive equilibrium. Isotopes - radioactive and non-radioactive isotopes, group displacement law. Analysis of isotopes – Aston’s mass spectrograph, Dempster’s method, Bainbridge’s method. Separation methods of isotopes. Applications of Radio isotopes in Industry and medicine.

Text books/ Reference books:

1. Physical chemistry, G.K. Vemulapalli (Prentice Hall of India).
2. Physical chemistry, P.W. Atkins. ELBS.
3. Chemical kinetics - K.J. Laidler, McGraw Hill Pub.
4. Text book of Physical Chemistry, Samuel Glasstone, Macmillan pub.
5. Statistical Thermodynamics - M.C.Gupta.
6. Polymer Science, Gowriker, Viswanadham, Sreedhar.
7. Quantitative Analysis, A.I. Vogel, Addison Wesley Longmann Inc.
8. Physical Chemistry by G.W.Castellan, Narosa Publishing House, Prentice Hall.
9. Physical Chemistry by W.J. Moore, Prentice Hall.
10. Polymer Chemistry by Billmeyer.
11. Fundamentals of Physical Chemistry by K K. Rohatgi-Mukherjee. Wiley Eastern Ltd publications.
12. Statistical Thermodynamics by M.Dole.
13. Fundamentals of photochemistry by Rohatgimukherjee, New Age international Publications.
14. Essentials of Nuclear chemistry by H.J.Armikar, New Age international Publications.

NOTE:Percentage of Change – 20%

**A.G.& S.G.SIDDHARTHA DEGREE COLLEGE OF ARTS &
SCIENCE(Autonomous)**

DEPARTMENT OF CHEMISTRY

M.Sc – CHEMISTRY (ORGANIC CHEMISTRY)

II SEMESTER

Paper Code & Title: CH206L1: ORGANIC CHEMISTRY PRACTICAL-II

No. of hours per week: 03 Total credits: 03

Total marks: 100 (Internal: 30 M & External: 70M)

Course Learning Objective(S): The main objective of this paper is to give a practical knowledge

for the students on Organic chemistry practical.

List of experiments:

1. Preparation of organic compounds: Single stage preparations by reactions involving nitration,

halogenation, oxidation, reduction, alkylation, acylation, condensation and rearrangement.

(A student is expected to prepare at least 5 different organic compounds by making use of the reactions given above).

2. Preparation of organic compounds: Two stage preparations by reactions involving nitration,

halogenation, oxidation, reduction, alkylation, acylation, condensation and rearrangement.

(A student is expected to prepare at least 5 different organic compounds by making use of the reactions given above).

3. Systematic qualitative analysis of organic compounds with different functional groups (5 different compounds)

Course Learning Outcome(S): After studying this paper, students will acquire the knowledge of

Organic chemistry practical.

Text books/ Reference books:

1. A.I.Vogel, "A Text Book of Practical Organic Chemistry", Longman
2. A.I.Vogel, "Elementary Practical Organic Chemistry", Longman
3. Practical Organic Chemistry, F.G.Mann and B.C.Saunders, Longman
4. Reaction and Synthesis in Organic Laboratory, B.S.Furniss, A.J.Hamaford, Tatchell, University Science Books Mills valley.
5. Purification of Laboratory chemicals, manual, W.L.F. Armarego EDD Perrin.
6. Reaction and Synthesis in Organic Chemistry Laboratory, Lutz-Friedjan-Tietze, TheophilEicher, University Science Book.

NOTE:PercentageofChange - 0%

A.G.&S.G.SIDDHARTHA DEGREE COLLEGE OF ARTS & SCIENCE

DEPARTMENT OF CHEMISTRY

M.Sc – CHEMISTRY (ORGANIC CHEMISTRY)

II SEMESTER

Paper Code & Title: 20OECH: (OPEN ELECTIVE-I)

CHEMISTRY IN DAILY LIFE

**No. of hours per week: 04
04**

Total credits:

**Total marks: 100
70M)**

(Internal: 30 M & External:

Course: CHEMISTRY IN DAILY LIFE (code 20OECH)		
S.No	COURSE OUTCOMES	PO'S
	The graduate will be able to	
1	Memorize the basic concepts related to chemistry in daily life like – chemistry Laboratory safety symbols, environmental chemistry, bioinorganic chemistry, vitamins, antibiotics and hormones.	2,7
2	Understand the concepts like chemistry Laboratory safety symbols, environmental chemistry, bioinorganic chemistry, vitamins, antibiotics and hormones.	1,2,6
3	Apply the knowledge gained in the concepts like chemistry Laboratory safety symbols, environmental chemistry, bioinorganic chemistry, vitamins, antibiotics and hormones in future job roles.	1,4,7

Course Learning Objective(S): The main objective of this paper is to give a basic and updated knowledge for the students on Chemistry Laboratory safety symbols – Meaning, Environmental Chemistry, Bioinorganic Chemistry, Biological functions of Hormones and Medicinal chemistry.

Unit-I: Chemistry Laboratory safety symbols – Meaning:

Corrosive, carcinogenic, Harmful, toxic, dangerous to environment, Explosive, flammable, Narcotic, Oxidizing, Lachrymatory, Radioactive, irritant, gases under pressure, general laboratory safety precautions.

Unit-II: Environmental Chemistry:

Ambient air quality standards, Acid rain, Smog, Greenhouse effect, Bhopal gas tragedy, Vishakhapatnam polymer industry tragedy, Renewable and Nonrenewable energy resources, DO, COD, BOD, Toxicity of lead, mercury, arsenic and Cadmium.

Unit-III: Bioinorganic Chemistry:

Essential elements, biological significance of Na, K, Mg, Ca, Fe, Metalloporphyrin – Structure and functions of hemoglobin, Myoglobin.

Unit-IV: Biological functions of Hormones:

Introduction, Types of hormones, Role of Andosterone, Progesterone and thyroxin, action of cortisone, Insulin.

Unit-V: Medicinal Chemistry:

The role of vitamins – K, E, D, C, B – complex, classification of antibiotics, mechanism of antibiotics action - role of ampicillin, chloromycetin and amoxicillin as antibiotics.

Text books/ Reference books:

1. Laboratory safety for Chemistry Students by Robert H. Hill and David Finster
2. A Text book of Environmental chemistry by W. Moore and F.A. Moore
3. Environmental Chemistry by Samir K. Banerji
4. Organic Chemistry by G. Mare Loudan, Purdue University
5. Unified Chemistry by O.P. Agarwal, Paper-III, JPNP Publications.
6. Hormones and Endocrine system – Kleine, Rossemanith.
7. Principles of Biochemistry-Leninger.
8. Essentials of Medical pharmacology- K. D. Tripathi.

A.G.&S.G.SIDDHARTHA DEGREE COLLEGE OF ARTS & SCIENCE

DEPARTMENT OF CHEMISTRY

M.Sc – CHEMISTRY (ORGANIC CHEMISTRY)

II SEMESTER

Paper Code & Title: 20OECH: (OPEN ELECTIVE-I)

CHEMISTRY IN DAILY LIFE

**No. of hours per week: 04
04**

Total credits:

**Total marks: 100
70M)**

(Internal: 30 M & External:

Course: CHEMISTRY IN DAILY LIFE (code 20OECH)		
S.No	COURSE OUTCOMES	PO'S
	The graduate will be able to	
1	Memorize the basic concepts related to chemistry in daily life like – chemistry Laboratory safety symbols, environmental chemistry, bioinorganic chemistry, vitamins, antibiotics and hormones.	2,7
2	Understand the concepts like chemistry Laboratory safety symbols, environmental chemistry, bioinorganic chemistry, vitamins, antibiotics and hormones.	1,2,6
3	Apply the knowledge gained in the concepts like chemistry Laboratory safety symbols, environmental chemistry, bioinorganic chemistry, vitamins, antibiotics and hormones in future job roles.	1,4,7

Course Learning Objective(S): The main objective of this paper is to give a basic and updated knowledge for the students on Chemistry Laboratory safety symbols – Meaning, Environmental Chemistry, Bioinorganic Chemistry, Biological functions of Hormones and Medicinal chemistry.

Unit-I: Chemistry Laboratory safety symbols – Meaning:

Corrosive, carcinogenic, Harmful, toxic, dangerous to environment, Explosive, flammable, Narcotic, Oxidizing, Lachrymatory, Radioactive, irritant, gases under pressure, general laboratory safety precautions.

Unit-II: Environmental Chemistry:

Ambient air quality standards, Acid rain, Smog, Greenhouse effect, Bhopal gas tragedy, Vishakhapatnam polymer industry tragedy, Renewable and Nonrenewable energy resources, DO, COD, BOD, Toxicity of lead, mercury, arsenic and Cadmium.

Unit-III: Bioinorganic Chemistry:

Essential elements, biological significance of Na, K, Mg, Ca, Fe, Metalloporphyrin – Structure and functions of hemoglobin, Myoglobin.

Unit-IV: Biological functions of Hormones:

Introduction, Types of hormones, Role of Andosterone, Progesterone and thyroxin, action of cortisone, Insulin.

Unit-V: Medicinal Chemistry:

The role of vitamins – K, E, D, C, B – complex, classification of antibiotics, mechanism of antibiotics action - role of ampicillin, chloromycetin and amoxicillin as antibiotics.

Text books/ Reference books:

1. Laboratory safety for Chemistry Students by Robert H. Hill and David Finster
2. A Text book of Environmental chemistry by W. Moore and F. A. Moore
3. Environmental Chemistry by Samir K. Banerji
4. Organic Chemistry by G. Mare Loudan, Purdue University
5. Unified Chemistry by O.P. Agarwal, Paper-III, JPNP Publications.
6. Hormones and Endocrine system – Kleine, Rossemanith.
7. Principles of Biochemistry-Leninger.
8. Essentials of Medical pharmacology- K. D. Tripathi.

A.G.&S.G.SIDDHARTHA DEGREE COLLEGE OF ARTS & SCIENCE

DEPARTMENT OF CHEMISTRY

M.Sc – CHEMISTRY (ORGANIC CHEMISTRY)

II SEMESTER

Paper Code & Title: 200ECH: (OPEN ELECTIVE-I)

CHEMISTRY IN DAILY LIFE

No. of hours per week: 04
credits: 04

Total

Total marks: 100
External: 70M)

(Internal: 30 M &

Course: CHEMISTRY IN DAILY LIFE (code 200ECH)		
S.No	COURSE OUTCOMES	PO'S
	The graduate will be able to	
1	Memorize the basic concepts related to chemistry in daily life like – chemistry Laboratory safety symbols, environmental chemistry, bioinorganic chemistry, vitamins, antibiotics and hormones.	2,7
2	Understand the concepts like chemistry Laboratory safety symbols, environmental chemistry, bioinorganic chemistry, vitamins, antibiotics and hormones.	1,2,6
3	Apply the knowledge gained in the concepts like chemistry Laboratory safety symbols, environmental chemistry, bioinorganic chemistry, vitamins, antibiotics and hormones in future job roles.	1,4,7

Course Learning Objective(S): The main objective of this paper is to give a basic and updated knowledge for the students on Chemistry Laboratory safety symbols – Meaning, Environmental Chemistry, Bioinorganic Chemistry, Biological functions of Hormones and Medicinal chemistry.

Unit-I: Chemistry Laboratory safety symbols – Meaning:

Corrosive, carcinogenic, Harmful, toxic, dangerous to environment, Explosive, flammable, Narcotic, Oxidizing, Lachrymatory, Radioactive, irritant, gases under pressure, general laboratory safety precautions.

Unit-II: Environmental Chemistry:

Ambient air quality standards, Acid rain, Smog, Greenhouse effect, Bhopal gas tragedy, Vishakhapatnam polymer industry tragedy, Renewable and Nonrenewable energy resources, DO, COD, BOD, Toxicity of lead, mercury, arsenic and Cadmium.

Unit-III: Bioinorganic Chemistry:

Essential elements, biological significance of Na, K, Mg, Ca, Fe, Metalloporphyrin – Structure and functions of hemoglobin, Myoglobin.

Unit-IV: Biological functions of Hormones:

Introduction, Types of hormones, Role of Andosterone, Progesterone and thyroxin, action of cortisone, Insulin.

Unit-V: Medicinal Chemistry:

The role of vitamins – K, E, D, C, B – complex, classification of antibiotics, mechanism of antibiotics action - role of ampicillin, chloromycetin and amoxicillin as antibiotics.

Text books/ Reference books:

1. Laboratory safety for Chemistry Students by Robert H. Hill and David Finster
2. A Text book of Environmental chemistry by W. Moore and F.A. Moore
3. Environmental Chemistry by Samir K. Banerji
4. Organic Chemistry by G. Mare Loudan, Purdue University
5. Unified Chemistry by O.P. Agarwal, Paper-III, JPNP Publications.
6. Hormones and Endocrine system – Kleine, Rossemanith.
7. Principles of Biochemistry-Leninger.
8. Essentials of Medical pharmacology- K. D. Tripathi.

A.& S.G.SIDDHARTHA DEGREE COLLEGE OF ARTS & SCIENCE(Autonomous)
DEPARTMENT OF CHEMISTRY
M.Sc – CHEMISTRY (ORGANIC CHEMISTRY)
II SEMESTER

Paper Code & Title: CH207L2: PHYSICAL CHEMISTRY PRACTIAL

No. of hours per week: 03 Total credits: 03

Total marks: 100 (Internal: 30 M & External: 70M)

Course Learning Objective(S): The main objective of this paper is to give a practical knowledge

for the students on Inorganic and Physical chemistry experiments.

List of experiments:

1. Relative strengths of acids by studying the hydrolysis of ethyl acetate / methyl acetate.
2. Determination of equilibrium constant of $I_2 + I^- \rightleftharpoons I_3^-$ by partition coefficient.
3. Determination of unknown concentration of potassium iodide by partition coefficient method.
4. Distribution coefficient of Benzoic acid between Benzene and water.
5. Determination of critical solution temperature of phenol-water system.
6. Study of the effect of electrolyte on the miscibility of phenol-water system.
7. Determination of Coordination number of cuprammoniumcation.
8. Potentiometric determination of Fe(II) with Cr (VI).
9. Potentiometric determination of Fe(II) with Ce (IV).
10. pH-metric determination of strong acid with strong base.
11. Conductometric titration of strong acid with strong base.
12. Conductometric titration of strong acid + Weak acid with strong base.
13. Dissociation constant of weak acid (CH_3COOH) by conductometric method.
14. Determination of cell constant.
15. Verification of Beers Law using potassium permanganate/Potassium dichromate.

Course Learning Outcome(S): After studying this paper, students will acquire the knowledge of inorganic and Physical chemistry experiments.

Text books/ Reference books:

1. Experimental Physical chemistry by V.D. Athawale, Parul Mathur, New Age International publishers.
2. Physical chemistry experiments by V. P. Kudesia, Pragati Prakasan publishers.
3. Advanced practical Physical chemistry by J.B. Yadav, Krishna's educational publishers.

NOTE: Percentage of Change–27% (Increment)

**M.Sc. DEGREE EXAMINATION
SECOND SEMESTER**

Paper-I :: ORGANIC SPECTROSCOPY

Time: 3 hours

Maximum Marks: 70

SECTION – A

Answer all the questions. Each question carries 2 marks. (10x2=20M)

1. Discuss Auxochromes in UV visible spectroscopy in short. (CO-2)
2. Explain Woodward Fieser rules. (CO-2)
3. What is finger print region in IR Spectroscopy and discuss its importance (CO-3)
4. Discuss the mechanics of measurements in IR Spectroscopy in short. (CO-2)
5. Illustrate the basic principle of NMR spectroscopy. (CO-1)
6. What is chemical shift? Explain the significance of δ – scale. (CO-2)
7. Elaborate the importance of nitrogen rule in Mass Spectrometry. (CO-2)
8. Explain the role EI technique in ionization of molecules. (CO-2)
9. What is Stevenson's rule? (CO-1)
10. Write the list out the general modes of fragmentation. (CO-1)

SECTION – B

(10x5=50M)

UNIT - I

11.a) Write a detailed note on i) Types of shifts in UV ii) Electronic transitions in UV. (CO-2, L-2) (Or)

b) Calculate the λ_{max} of the following compounds

(CO-4, L-4)

(i)

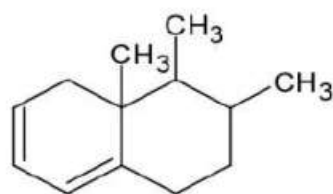

(ii)

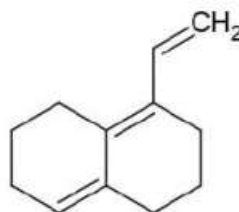

(iii)

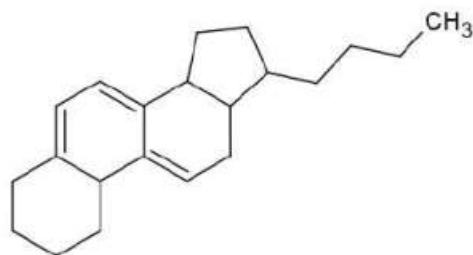

(iv)

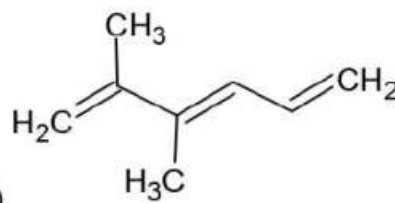

UNIT – II

12.a) Write a note on i) fundamental modes of vibrations ii) Factors effecting IR stretching frequency of organic compounds. (CO-3, L-

3)

(Or)

- b) How will you distinguish o-hydroxybenzaldehyde and p-hydroxybenzaldehyde on the basis of IR spectroscopy ii) How will you distinguish the following pairs by the use of their IR spectra (i) $\text{CH}_3\text{CH}_2\text{CHO}$ and CH_3COCH_3 (ii) $\text{CH}_3\text{CH}_2\text{NH}_2$ and CH_3NHCH_3 (CO-3,L-3)

UNIT – III

13. a) Define Chemical shift. Give an account on Chemical exchange in NMR. (CO- 2)
 b) Predict the number of signals and their chemical shift in each of the following compounds (CO-3)

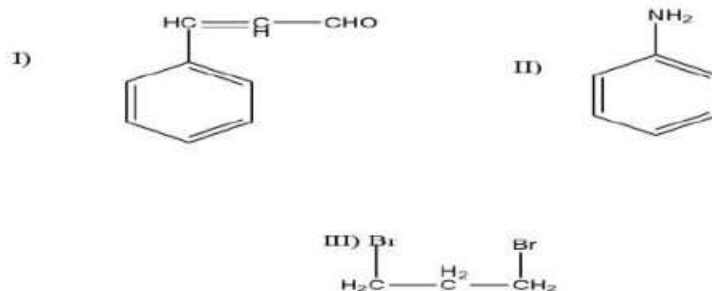

(Or)

- c) A compound of Molecular weight 122, in its PMR Spectrum shows 1.4(T,3H), 0(Q,2H), 6.8-7.2(M,5H). Write structure of compound using above data. (CO-3)
 d) Explain the coupling constant in NMR and describe about various types of coupling constants (CO-2)

UNIT - IV

- 14 a) The mass spectrum of an unknown compound shows a molecular ion peak at $m/z = 78$ with a relative intensity of 23.6 and the relative intensities of the isotopic peaks are as follows m/z 79(1.00), 80(7.55), 81(.25). what is the molecular formula of this unknown? (CO- 3)

(Or)

- b) what is the principle of mass spectrometry?. Discuss some quantitative and qualitative applications of mass spectrometry. (CO-2)

UNIT - V

- 15 a) In the mass spectrum of 1-hexanol, a very weak molecular ion peak appears at $m/z = 102$. Some other prominent peaks appear at m/z values of 100,99,84, 56(base peak) and 31. What are the most probable species responsible for the above mentioned peak positions. (CO-3)

(Or)

- b) How mass spectrum is useful to distinguish between 1^o, 2^o, 3^o aliphatic amines? (CO- 4)
 c) Illustrate Mc Lafferty rearrangement with suitable examples (CO-2)

**M.Sc. DEGREE EXAMINATION
SECOND SEMESTER**

Paper-II :: Inorganic Chemistry - II

Time: 3 hours

Maximum Marks: 70

SECTION – A

Answer all the questions. Each question carries 2 marks. (10x2=20M)

1. Write a short note on Phosphorous-Sulphur cages. (CO-2)
2. Explain the bonding aspects of $[\text{Nb}_6\text{Cl}_{12}]^{2-}$. (CO-2)
3. Define hapticity. (CO-1)
4. Elaborate the classification of organometallic compounds. (CO-1)
5. Derive rate law of Anation reaction. (CO-2)
6. Write note on complementary and non-complementary reactions. (CO-2)
7. Discuss how Hund's rules can be used to predict ground terms. (CO-2)
8. Derive the ground term of d^3 and d^9 metal ions. (CO-3)
9. Give a short account on Faraday Effect. (CO-2)
10. Deliberate the effect of spin orbital coupling on magnetic moments. (CO-3)

SECTION – B

(10x5=50M)

UNIT - I

11. a) Describe the bonding and structure in higher boranes and Metalloboranes. (CO-2)
(Or)
b) Discuss the structure and bonding in $[\text{Re}_2\text{Cl}_8]^{2-}$ ion. (CO-2)

UNIT – II

12. a) Elucidate the applications of organometallic compounds in catalytic hydrogenation and hydro formylation. (CO-3)
(Or)
b) Explain oxidative addition, reductive elimination reactions of organometallic compounds. (CO-2)

UNIT – III

13. a) Explain the outer sphere mechanism of redox reactions. (CO-2)
(Or)
b) Discuss the direct and indirect evidences in favour of conjugate base mechanism. (CO-3)

UNIT - IV

14. a) Discuss the calculation of D_q and β parameters. (CO-3)
(Or)
b) Draw the Orgel diagram and Tanabe Sugano diagram for d^2 and d^9 Configuration and explain. (CO-2)

UNIT - V

15. a) Discuss the storage of dioxygen by myoglobin and write its importance. (CO-2)
(Or)
b) Describe the factors affecting para magnetism. (CO-2)

**M.Sc. DEGREE EXAMINATION
SECOND SEMESTER**

Paper-III :: Organic Chemistry - II

Time: 3 hours

Maximum Marks: 70

SECTION – A

Answer all the questions. Each question carries 2 marks. (10x2=20M)

1. Explain Shaciro reaction. (CO - 2)
2. Explain stobbe condensation. (CO - 2)
3. Write notes on configuration and conformation. (CO - 1)
4. Explain enantiomers with suitable examples. (CO - 1)
5. Draw the structures of the cyclohexane boat and twist boat structures. (CO - 1)
6. Discuss conformation and intramolecular hydrogen bonding. (CO - 2)
7. Discuss Clean Fischer Indole synthesis (CO - 3)
8. Write notes on Biocatalysis. (CO - 1)
9. Define nano explain. (CO - 1)
10. Write general properties of carbon nano tubes. (CO - 1)

SECTION – B

(10x5=50M)

UNIT - I

11. a) Discuss the mechanism of the following
(i) Benzoin condensation. (ii) Reformatsky reaction. (CO - 2)
(Or)
b) Discuss the definition and mechanism of
(i) Wittig reaction (ii) Acyloin condensation.
(CO - 2)

UNIT - II

12. a) Explain the various elements of symmetry with suitable examples. (CO - 1)
(Or)
b) Discuss the various methods for determination of configuration of geometrical isomers with suitable examples. (CO - 1)

UNIT - III

13. a) Discuss the conformational analysis of cyclohexane and explain the stabilites.(CO - 1)
(Or)
b) Write an account of comformation around C – N and C – O hetero atom bond(CO -1)

UNIT – IV

14. a) Discuss the principles of green chemistry. (CO - 2)
(Or)
b) Explain the theory, principle and advantages of MicroWave (MW) organic synthesis.
(CO - 2)

UNIT – V

15. a) Explain growth mechanism of carbon nanotubes. (CO - 2)
(Or)
b) Give an applications of carbon nanotubes. (CO - 2)

**M.Sc. DEGREE EXAMINATION
SECOND SEMESTER**

Paper-IV :: Physical Chemistry - II

Time: 3 hours

Maximum Marks: 70

SECTION – A

Answer all the questions. Each question carries 2 marks. **(10x2=20M)**

1. Explain briefly Nernst Heat theorem. (CO-2,L-2)
2. Discuss Third law of thermodynamics in short. (CO-2,L-2)
3. Demonstrate Classification of polymers. (CO-3,L-3)
4. Describe the Free radical polymerization with appropriate mechanism. (CO-2,L-2)
5. Explain Branching Chain Reactions in short. (CO-2,L-2)
6. Discuss briefly Hydrogen oxygen reaction with appropriate mechanism. (CO-2,L-2)
7. Discuss briefly Double layer at the interface. (CO-2,L-2)
8. Explain over potential in short. (CO-2,L-2)
9. What are Schoenfiles Symbols. (CO-2,L-2)
10. Define group theory and Sub group. (CO-2,L-2)

SECTION – B

(10x5=50M)

UNIT - I

11. a) Derive Fermi-Dirac statistics (CO-3,L-3)
 - b) Derive Bose Einstein statistics (CO-3,L-3)
- (Or)**
- c) Derive Chemical equilibrium interms of partition function. (CO-3,L-3)
 - d) Derive Entropy of Monoatomic gases (Sackur-Tetrode equation). (CO-3,L-3)

UNIT - II

- (ii) a) Illustrate Zeigler -Natta Polymerization with suitable example. (CO-3,L-3)
 - b) What is Glass transition temperature ? Demonstrate Factors influencing the glass transition temperature. (CO-3,L-3)
- (Or)**
- c) Differentiate between Number average and Weight average weight of a polymer in detail. (CO-3,L-3)

UNIT - III

- 13.a) Discuss with a neat labelled diagram Standard hydrogen electrode and Calomel electrode in detail. (CO-2,L-2)
- (Or)**
- b) Demonstrate the Conductometric titrations in detail with a neat labelled graphs. (CO-3,L-3)

UNIT – IV

- 14.a) What are Fast reactions ? Discuss the Study of kinetics by flow methods and Relaxation methods With a neat labeled diagram. (CO-3,L-3)
- (Or)**
- b) Differentiate between protolytic and prototropic mechanisms of Acid Base catalysis. (CO-3,L-3)

UNIT - V

- 15.a) Construct the Character table for C_{3v} point group using the implications of orthogonality theorem (CO-2,L-2)
- (Or)**
- b) State the axioms of Group theory and show that C_{2v} is an abelian group. (CO-2,L-2)

A.G.& S.G.SIDDHARTHA DEGREE COLLEGE OF ARTS &SCIENCE(Autonomous)
Department of Chemistry

CIA Practicals

Total Marks – 30 M

1. Lab Performance / per experiment – 20 Marks

Experiment	– 10 Marks
Observation	– 5 Marks
Result / Yield / Report	– 5 Marks

2. Semester End Internal Exam – 10 Marks

Experiment	– 7 Marks
Result / Yield / Report	– 3 Marks

M.Sc. DEGREE EXAMINATION

Internal Practical Model Paper

(Regulation 2017-2018)

Time: 6 hours

Maximum Marks: 30

1. Experiment – 20 Marks
2. Result / Graphs / Yield / Report – 10 Marks

M.Sc. DEGREE EXAMINATION

External Practical Model Paper

(Regulation 2017-2018)

Time: 6 hours

Maximum Marks: 70

1. To write the principle and procedure / mechanism related to practical as listed in the practical syllabus – 5 M
2. Record – 10 M
3. Experiment (Procedure / Tabulation / calculation etc.) – 50 M
4. Result / Graphs / Yield / Report – 5 M

A.G.& S.G.SIDDHARTHA DEGREE COLLEGE OF ARTS & SCIENCE
DEPARTMENT OF CHEMISTRY
M.Sc – CHEMISTRY (ORGANIC CHEMISTRY)
IV SEMESTER

20CH4T1: MOOCS – ORGANIC CHEMISTRY - I

Course: MOOCS – ORGANIC CHEMISTRY - I		
S.No	COURSE OUTCOMES	PO'S
	The student will be able to	
1	Recollect the concepts of stereochemistry, conformational analysis, CD & ORD, nature of bonding, aromaticity, chemical kinetics and reactive intermediates.	2,7
2	Identify the role of stereochemistry, conformational analysis, CD & ORD, nature of bonding, aromaticity, chemical kinetics and reactive intermediates.	1,2,3
3	Demonstrate the knowledge of stereochemistry, conformational analysis, CD & ORD, nature of bonding, aromaticity, chemical kinetics and reactive intermediates in chosen fields..	1,6,7
4	Analyze the conceptual knowledge in stereochemistry, conformational analysis, CD & ORD, nature of bonding, aromaticity, chemical kinetics and reactive intermediates in the reactions.	1,5,6

Course Learning Objective(S): The main objective of this paper is to give a basic and updated knowledge for the students on Heterocyclic Chemistry.

UNIT-I

Stereo Chemistry : Concept of chirality, Recognition of Symmetry elements. Definition and classification of Stereoisomers, Enantiomer, Diastereomer, Homomer, Epimer, Anomer, Configuration and Conformation, Configurational nomenclature: D,L and R, S nomenclature.

Molecular representation of organic molecules: Fischer, Newman and Sawhorse projections and their inter-conversions. Geometrical isomerism. Cis-trans, E, Z- and Syn and Anti

nomenclature, Methods of determining configuration of Geometrical isomers using physical, spectral and chemical methods.

UNIT-II

Conformational Analysis and ORD, CD Curves:

Definition of Conformation, Conformational analysis of acyclic molecules – alkanes and substituted alkanes. Conformational analysis of monocyclic molecules – cyclohexane – chair, boat and twist boat - mono and disubstituted cyclohexanes and conformation around carbon hetero atom bonds having C–O & C–N. Confirmation and intramolecular hydrogen bonding.

Optical rotatory dispersion: Theory of optical rotatory dispersion – Cotton effect – CD curves-types of ORD and CD curves-similarities and difference between ORD and CD curves. α - Halo keto rule, Octant rule – application in structural studies.

UNIT-III

Nature of bonding and Aromaticity: Nature of bonding: Localised and Delocalized, Delocalised chemical bonding, conjugation, cross conjugation, hyper conjugation, Tautomerism.

Aromaticity: Concept of Aromaticity, Aromaticity of five membered, six membered rings - Non benzenoid aromatic compounds:-cyclopropenylcation, Cyclobutadienyldication, cyclopentadienyl anion-tropyllium cation and cyclooctatetraenyl dianion. Homoaromaticity, Anti aromaticity.

Aromatic Nucleophilic substitution: The S_NAr (Addition – Elimination), $S_N1(Ar)$ mechanisms and benzyne mechanism (Elimination – Addition). Reactivity- effect of substrate structure, leaving group and attacking nucleophile. The Von-Richter, Sommelet – Hauser and Smiles rearrangements.

UNIT-IV

Chemical kinetics- Methods of deriving rate laws - complex reactions - Rate expressions for opposing, parallel and consecutive reactions involving unimolecular steps. Theories of reaction rates -collision theory - Steric factor - Activated complex theory - Thermodynamic

aspects – Unimolecular reactions - Lindemann's theory - Lindemann-Hinshelwood theory.
Reactions in solutions - Influence of solvent - Primary and secondary salt effects.

UNIT- V

Reactive intermediates, Reactive Species, Linear free energy relations: Generation, Structure, Stability, Detection and Reactivity of Carbocations, Carbanions, Free radicals, Carbenes, Nitrenes and Arynes.

Reactive Species: Generation and reactivity of Electrophiles, Nucleophiles, Dienophiles, Ylids.

Elementary account of linear free energy relationships - Hammett - Taft equation - Chain reactions – Rate laws of H_2-Br_2 , photochemical reaction of $H_2 - Cl_2$ Decomposition of acetaldehyde and ethane - Rice- Herzfeld mechanism.

Referencebooks:

1. Some Modern Methods of Organic Synthesis W.Caruthers, Cambridge University Press, Cambridge.
2. Organic Synthesis viz Boranes, HerbertC. BrownGray, W.KramerAlanB.LevyandM.MarkMidl and John Willy & Sons, NewYork.
3. Heterochemistry, T.L.Gilchrist, Longmanscienceandtech.
4. Anintroduction to the Chemistry of Heterocyclic Compounds, R.M.Acheson, Interscience Publishers, NewYork
5. Principle of Organic Chemistry, RocNorman, J.M.Coxon, NelsonThroms
6. Advanced Organic Chemistry, F.ACarey and R.J.Sundberg.Plenum.
7. Heterocyclic chemistry by JaiJackLie, Springer publications.
8. Chemical kinetics - K.J.Laidler, McGraw Hill Pub.

20CH4T2A :HETERO CYCLIC CHEMISTRY

Course:HETERO CYCLIC CHEMISTRY		
S.No	COURSE OUTCOMES	PO`S
	The student will be able to	
1	Memorize the synthetic routes and reactions related to three, four, five, six membered and fused heterocyclic compounds.	2,7
2	Understand the concepts of synthesis and reactions of three, four, five, six membered and fused heterocyclic compounds.	1,7
3	Apply the conceptual knowledge gained in the synthesis and reactions of organic synthesis three, four, five, six membered and fused heterocyclic compounds as and when required.	1,6,4
4	Analyse and categorize the various reactions involved in the synthesis of three, four, five, six membered and fused heterocyclic compounds	1,5,7

Course Learning Objective(S): The main objective of this paper is to give a basic and updated knowledge for the students on Heterocyclic Chemistry.

UNIT-I

Definition, Classification and Nomenclature (Hantzsch Widman System) of hetero cycles.

Three membered Heterocyclic Compounds: Synthesis, reactivity, and importance of the following ring systems: Aziridines, Oxiranes, Thiiranes, azirine.

UNIT-II

Four membered Heterocyclic Compounds: Synthesis, reactivity, and importance of the following ring systems :Azetidines, oxetanes, Thietanes.

Fused systems: Synthesis and reactivity of Penicillins G and V.

UNIT-III

Five membered Heterocyclic Compounds with two hetero atoms: Synthesis, reactivity, aromatic character, and importance of the following heterocycles: Pyrazole, Imidazole, Oxazole, Isoxazole, Thiazole.

Fused systems: Synthesis and reactivity of Indoles and Benzimidazoles.

UNIT-IV

Six-membered Heterocyclic Compounds with two hetero atoms: Synthesis, reactivity, aromatic character and importance of the following heterocycles: Pyridazines, Pyrazine, Oxazine, Thiazine.

Fused systems: Acridines and Benzodiazines.

UNIT- V

Larger ring and other Heterocycles: Synthesis and reactivity of Azepines, Oxepines and Thiepinines. Synthesis and reactivity of Benzodiazepines.

Course Learning Outcome(S): After studying this paper, students will acquire the knowledge of Heterocyclic Chemistry.

Reference books:

1. Some Modern Methods of Organic Synthesis W.Caruthers, Cambridge University Press, Cambridge.
2. Organic Synthesis viz Boranes, Herbert C. Brown Gray, W.Kramer Alan B.Levy and M.Mark Midland John Willy & Sons, New York.
3. Heterochemistry, T.L.Gilchrist, Longman science and tech.
4. An introduction to the Chemistry of Heterocyclic Compounds, R.M.Acheson, Interscience Publishers, New York
5. Principle of Organic Chemistry, R.C.Norman, J.M.Coxon, Nelson Thomsons
6. Advanced Organic Chemistry, F.A.Carey and R.J.Sundberg. Plenum.
7. Heterocyclic chemistry by Jai Jack Lie, Springer publications.

20CH4T2 B : GREEN CHEMISTRY

Course:GREEN CHEMISTRY		
S.No	COURSE OUTCOMES	PO`S
	The student will be able to	
1	Memorize the principles of green chemistry and concepts related to green organic synthesis.	2,7
2	Understand the role and significance of green organic synthesis.	1,5,7
3	Exercise the basic and advanced knowledge gained on green organic synthesis in chosen job role.	1,4,6
4	Analyse how far green methods are environmentally benign over conventional methods of synthesis.	1,3

Unit-I

Principles of Green Chemistry: Prevention of waste / by-products, atom economy, Hazardous products-Designing of safer chemicals-energy requirements Selection of appropriate solvents and starting materials-Use of protecting groups and catalysis-Designing of biodegradable products. green organic synthesis of paracetamol, catechol, adipic acid, urethane and ibuprofen.

Unit-II

Microwave assisted reactions: Theory of Microwave, advantages, disadvantages, applications- water as solvent: Hoffmann elimination, hydrolysis, oxidation of Toluene, oxidation of alcohols, hydrolysis of methyl benzoate to benzoic acid.

Organic solvents: Esterification reactions, Fries rearrangement, Ortho ester Claisen rearrangement, DielsAlder reactions, synthesis of chalcones, decarboxylation.

Solid state reactions (solvent free): De acetylation, deprotection, saponification of esters, synthesis of anhydrides from dicarboxylic acid, synthesis of nitriles from aldehydes.

Unit-III

Phase Transfer Catalysis: Definition, Mechanism, Types, advantages and applications of PTC – C-alkylation, N-alkylation, Darzen's reaction, Wittig reaction, Benzoyl cyanides from benzoyl chloride, alcohols from alkyl halides, Crown ethers – Introduction, synthetic

applications: esterification, saponification, Anhydride formation, KMnO_4 oxidation, aromatic substitution, elimination.

Unit-IV

Ultrasound assisted green synthesis: Introduction, instrumentation, types of sono chemical reactions – Homogeneous reactions – Curtius rearrangement of Benzoyl azide to phenyl isocyanate. Heterogeneous Liquid-Liquid reactions - Esterification, saponification, Hydrolysis, substitutions, additions. Heterogeneous Solid – Liquid Reactions–oxidation, reduction, hydroboration, coupling, Bouveault reaction, Strecker reaction.

Unit-V

Ionic liquids: Definition-Types of Ionic Liquids- properties- Application in organic synthesis- alkylation, allylation, oxidation, hydrogenation, hydroformylation, alkoxy carbonylation, carbon-carbon bond forming reactions-suzuki coupling, Heck reaction, stille coupling.

Textbooks/Referencebooks:

1. New Trends in Green Chemistry by V.K.Ahluwalia, M.Kidwai.
2. Green Chemistry: Environment Friendly Alternatives by Rashmi Sanghi, M.M.Srivastava
3. Green Solvents for Organic Synthesis by V.K.Ahluwalia, RajenderS.Varma.

20CH4T3 A: TECHNIQUES FOR MODERN INDUSTRIAL APPLICATIONS

COURSE :TECHNIQUES FOR MODERN INDUSTRIAL APPLICATIONS		
S.No	COURSE OUTCOMES:	PO'S
	The student will be able to	
1	Comprehend the concepts of purification methods and chromatographic methods.	2,7
2	Exercise the knowledge gained in purification and chromatographic techniques in their chosen job role.	1,4,6
3	Exercise that how far the purification and chromatographic techniques are useful in assessing the purity of the compound.	1,3,7
4	Evaluate that how far a compound is purified / separated using purification and chromatographic techniques.	1,5,7

UNIT-I

Classical Methods of purification Recrystallization: Basic principle, choice of solvent, seeding, filtration, centrifugation and drying. Concepts of fractional crystallization.

Distillation: Basic principle. Distillation types- continuous distillation, batch distillation, fractional distillation, vacuum distillation and steam distillation.

UNIT-II

Thin Layer chromatography:

Basic Principle, Common stationary phases, Methods of preparing TLC plates, Selection of mobile phase, Development of TLC plates, Rf value. Application of TLC in monitoring organic reactions. identification and quantitative analysis.

UNIT-III

Paper chromatography:

Basic Principle, Ascending and descending types. Selection of mobile phase, Development of chromatograms, One and two dimensional paper chromatography, Applications of paper chromatography.

UNIT-IV

Gas chromatography:

Basic Principle, Different types of GC techniques. Selection of columns and carrier gases. Instrumentation. detectors; Rf values. Applications in the separation, identification and quantitative analysis of organic compounds.

UNIT-V

High Performance liquid chromatography(HPLC):

Basic Principle, Normal and reversed Phases. Selection of column and mobile phase. Instrumentation. Detectors; Rf values. Applications in the separation, identification and quantitative estimation of organic compounds.

SUGGESTED BOOKS:

1. Principles of Instrumental Analysis by D. A. Skoog, F. J. Holler and T. A. Nieman, Harcourt College Pub.
2. Separation Techniques by M. N. Sastri, Himalaya Publishing House (HPH), Mumbai.
3. Bio Physical Chemistry by A. Upadhyay, K. Upadhyay and N. Nath,(HPH) , Mumbai.
4. A Hand Book of Instrumental Techniques for Analytical Chemistry- Ed-F. A. Settle, Prearson Edn, Delhi.27
5. Introduction to Organic Laboratory Techniques-D. L. Pavia, G. M. Lampman,G. S. Kriz and R. G. Engel, Saunders College Pub (NY).
6. Instrumental methods of Chemical Analysis by B. K. Sharma, Goel Publish House, Meerut.
7. Instrumental methods of Chemical Analysis by H. Kaur, Pragati Prakasan, Meerut.
8. Protein Purification-Principles and practice, III Edn- R. K. Scopes, Narosa Publishing House , Delli.

20CH4T3 B : NANO CHEMISTRY

Course:NANO CHEMISTRY		
S.No	COURSE OUTCOMES	PO'S
	The student will be able to	
1	Will be able to memorize the basic concepts of nanochemistry and nano materials.	2,7
2	Understand the basic and advanced concepts of nanochemistry and nano materials	1,5,7
3	Apply the knowledge gained in the field of nanochemistry as and when required.	1,3,6
4	Analyse the role of nanochemistry in various interdisciplinary sciences.	1,5

Course Learning Objective(S): The main objective of this paper is to give a basic and updated knowledge for the students on Nano Chemistry.

Unit-I

Introduction to Nano chemistry: Definition of terms-nanoscale, nanomaterials, nanoscience, nanotechnology-scale of materials natural and manmade-nanoscience practiced during ancient and modern periods-contributors to the field of Nanochemistry.

Unit-II

Synthesis of Nanomaterials: Top down and bottom- up approaches-synthesis of carbon nanotubes, quantumdots, gold and silver nanoparticles.

Unit-III

Characterization of Nano materials: Electron microscopy techniques-scanning electron microscopy, transmission electron microscopy and atomic force microscopy.

Unit-IV

Application of Nanomaterials: Solar cells-smart materials-molecular electronics-biosensors-drug delivery and therapy-detection of cancerous cells.

Unit-V

Nanochemistry in Nature: The science behind the nanotechnology in lotus effect-self-cleaning property of lotus-gecko foot climbing ability of geckos-water strider-anti wetting property of water striders-spider silk mechanical properties of the spider silk.

Textbooks/ Reference books:

1. Nano: The Essentials: Understanding Nanoscience and Nanotechnology, T.Pradeep, McGraw-Hill Professional Publishing, 2008.
2. Introduction to Nanoscience, J.Dutta, H.F.Tibbals and G.L.Hornyak, CRCpress, BocaRaton, 2008.

20CH4T4: ORGANO METALLIC REAGENTS

Course:ORGANO METALLIC REAGENTS		
S.No	COURSE OUTCOMES	PO`S
	The student will be able to	
1	Memorize the synthetic routes and applications of organo metallic reagents.	2,7
2	Appreciate the methods of synthesis and reactivity of various organo metallic reagents	1,3,7
3	Investigate the conceptual knowledge in various organo metallic reagents in organic synthesis	1,6,3
4	Assess the role of specific organic reaction reagents in the synthesis	1,6,5

Course Learning Objective(S): The main objective of this paper is to give a basic and updated knowledge for the students on Organometallic Reagents.

UNIT-I

Organo Magnesium and Lithium compounds: Preparation of Grignard reagents with alkyl, allyl, and propargyl halides, alkylation reaction with carbonyl compounds, esters, imines and nitriles, epoxides, acids, acid chlorides, carbon dioxide, carbon disulfide, sulfur dioxide. Preparation of alkyllithium reagents, Lithium Di isopropyl amide (LDA) and its synthetic applications.

Unit-II

Organo Copper and Nickel compounds: Organo copper reagents - preparation, reactions, organocuprates, lithium organocuprates (Gilman reagents). Organonickel compounds: π -allylnickel complexes, preparation of 1,5 cyclic dienes, nickel carbonyl.

Unit-III

Organo Palladium compounds: Preparation of palladium reagents, π -allyl palladium complexes – formations, reactions – prenylation, formation of conjugated dienes, synthesis of macro cyclic nitrogen hetero cyclic. Heck reaction, Stille coupling reaction, Sonogashira coupling reaction, Suzuki coupling reaction.

Unit-IV

Organoboranes: Preparation of Organoboranes viz hydroboration with BH_3 -THF, dicyclohexyl boranes, disiamylborane, tetrylborane, 9-BBN and catechol boranes. Protonolysis, oxidation, isomerization and cyclization. Free radical reactions of organoboranes, reactions with α -bromo ketones, α -bromo esters, carbonylation, the cyanoborate process and the reaction of alkenyl boranes and trialkyltrialkynyl borates.

Unit-V

Organosilanes: Synthetic applications of organo silicon compounds, protection of functional groups, trimethylsilyl ethers, silylenoethers, trimethylsilyliodide, trimethylsilyl triflate, Peterson olefination. Synthetic applications of α -silyl carbanion and β -silyl carbonyl compounds, alkenylsilanes, Allylsilanes, the β -effect - control of rearrangement of carbonium ions by silicon.

Reference books:

1. Organometallic in Synthesis A Manual by M. Schlosser, L. Hegedus, B. Lipshutz et al, John Wiley & Sons.
2. Modern methods of organic synthesis by W. Carruthers (Cambridge).
3. Organic synthesis by H.O. House.
4. Organometallics: A concise introduction, Christoph Elschenbroich, 3rd edition, Wiley-VCH.
5. Advanced Organic Chemistry, F.A. Carey and R.J. Sundberg, Plenum.
6. Transition metals in the synthesis of complex organic molecules, Hegedus, L.S., 2nd edition, University Science, Book, CA, 1999.
7. Organometallic Chemistry and Catalysis, Astruc, D., Springer Verlag, 2007.
8. Organotransition metal chemistry: Applications to organic synthesis, Davies, S.G., Pergamon Press, New York, 1986.

Add on Course in Chemistry (PG)

**ORGANOMETALLIC CHEMISTRY & METAL MEDIATED ORGANIC
SYNTHESIS**

Overview

The course covers an advance level of organometallic chemistry and recent development of cross coupling reactions and their applications in organic synthesis,

Syllabus

UNIT – I

Introduction of Organometallic Chemistry, Ligand Substitution Reactions, Oxidative Addition [1. Concerted Mechanism], Oxidative Addition [2. SN2 Mechanism], Oxidative Addition [3. Radical Mechanism], Reductive Elimination, Insertion and elimination.

UNIT – II

Hydrogenation of Alkenes, Hydrosilation reaction, Hydroformylation reaction, Alkene dimerization, Alkene polymerization, Monsanto acetic acid process, Wacker process, Synthetic gasoline, Synthetic gas

UNIT - III

Asymmetric hydrogenation, Kumada Coupling reaction, Suzuki coupling reaction, Stille coupling reaction, Sonogashira coupling reaction, Heck coupling reaction

UNIT – IV

Metathesis of olefins and alkynes, Buchwald-Hartwig coupling reaction, Kulinkovich Reaction and its mechanism, Pauson-Khand reaction, Glaser coupling reaction, Nozaki-Hiyama-Kishi coupling reaction

Reference books:

1. Organometallic Chemistry – R C Mehrotra and A Singh, New Age Publications
2. Inorganic Chemistry- Principles of Structure and Reactivity, James E Huheey, Ellen A. Keiter,
Richard L. Keiter, Pearson Education
3. Advanced Inorganic Chemistry- F A Cotton, G Wilkinson, Carlos A. Murillo, Manfred
Bochman- John Wiley and Sons.
4. Inorganic Chemistry – Allan G Sharpe, Addison Wesley
5. Organic Synthesis – Michael B. Smith (2nd Edition – McGraw Hill
6. Name Reactions – Jie Jack Li – (2nd Edition – Springer)
7. Organic Chemistry – Clayden, Greeves, Warren and Wothers (Oxford University Press)
8. Advanced Organic Chemistry – Francis A. Carey and Richard J. Sundberg – Part B –
Reactions and Synthesis. Kluwer Academic / Plenum Publishers.

9. Advanced Organic Chemistry – Francis A. Carey and Richard J. Sundberg – Part A –
Structure and Mechanisms – Kluwer Academic / Plenum Publishers.

CH4L1: ORGANIC ESTIMATIONS

Course: ORGANIC ESTIMATIONS (20CH4L1)		
S.No	COURSE OUTCOMES	PO'S
	The student will be able to	
1	Memorize the basic principles involved in organic quantitative analysis.	1,3,5
2	Understand the importance of organic quantitative analysis and their use on research and industry.	
3	Exercise the procedure of quantitative analysis in chosen job roles.	
4	Evaluate how far these methods are accurate in quantitative determinations.	

Expt. 1: Estimation of phenol (bromination method)

Expt. 2: Estimation of aniline (Bromination method)

Expt.3: Estimation of sugars –glucose and sucrose by using Fehlings solution

Expt. 4: Determination of iodine value of oil or fat

Expt. 5: Determination of saponification value of oil or fat

Expt. 6: Estimation of vitamin 'C' in lime juice.

Expt. 7: Estimation of Nitro group

Expt. 8: Estimation of formaldehyde

Expt. 9: Isolation of caffeine from tea/coffee sample.

Part-III: Record Submission **10M**

20CH4L2: PROJECT WORK

Project: PROJECT WORK (code 20CH4L2)		
S.No.	COURSE OUTCOMES	PO'S
	The student will be able to	
1	Acquire required skills to implement theoretical knowledge gained.	1,3,4,7
2	Assimilate the required knowledge for future research through practical knowledge gained in the project work.	1,2,7
3	Gain the required ability to start up own industry.	1,4,5,6
4	Comprehend the ability to draft and communicate the practical work.	1,2,7

The project will be assigned in the final semester. The project will be performed at the established industry (or) in the department under the supervision of the faculty or research institutes. It may involve experimental and/or theoretical work as well as critical review of the literature. Each of the students has to carry out original research in a topic in accordance with the work chosen under the guidance and supervision of a teacher in the concerned Department of the college.

- Isolation and characterization of Natural Products.
- Synthesis and characterization of Hetero Cyclic Compounds.
- Spectroscopical study of Organic compounds.
- Industrial visit and submit research findings of their Industrial visit / IIT's, CSIR Lab's, NIT's Central Universities etc.,

**M.Sc. DEGREE EXAMINATION
FOURTH SEMESTER**

Paper-I :: MOOCS

Time: 3 hours

Maximum Marks: 70

SECTION – A

Answer all the questions. Each question carries 2 marks.
(10x2=20M)

- | | |
|---|-------|
| 11. What is toxicology and explain with a suitable example. | (L-2) |
| 12. Discuss any one method of quantitative analysis. | (L-1) |
| 13. Explain equilibria between strong and weak acids. | (L-2) |
| 14. Discuss salt hydrolysis in detail. | (L-2) |
| 15. Explain Beers law in detail. | (L-2) |
| 16. Discuss chromophores in detail. | (L-2) |
| 17. Explain uses of oxidizing and reducing agents. | (L-1) |
| 18. Discuss IR drop in electrochemical cells. | (L-2) |
| 19. Explain thermo gravimetric analysis. | (L-3) |
| 20. Discuss differential thermal analysis. | (L-2) |

SECTION – B

(10x5=50M)

UNIT – I

- | | |
|---|-------|
| 21. a) Explain flow diagrams in detail. | (L-2) |
| (Or) | |
| b) Explain (i) Micro analytical balance (ii) Filtration techniques. | (L-2) |

UNIT – II

- | | |
|---|-------|
| 12. a) Explain the types of equilibria on basis of chemical analysis. | (L-2) |
| (Or) | |
| b) Discuss in detail (i) Titration curves (ii) Common ion effect. | (L-2) |

UNIT – III

- | | |
|--|-------|
| 13. a). Explain d – d, f – f transitions and its applications in detail. | (L-2) |
| (Or) | |
| b) Discuss chromophoric reagents and applying Beers law to mixtures. | (L-2) |

UNIT – IV

- | | |
|--|-------|
| 14. a) Discuss the (i) differential scanning calorimetry (ii) TG – plot. | (L-3) |
| (Or) | |
| b) Discuss (i) Geometric estimation (ii) Furnaces and crucibles | (L-2) |

UNIT - V

- | | |
|---|-------|
| 15. a) Discuss in detail potentiometric titrations with a neat labeled diagram. | (L-2) |
| (Or) | |
| b) Explain controlled potential coulometry with a neat labeled diagram. | (L-3) |

M.Sc. DEGREE EXAMINATION

FOURTH SEMESTER

Paper-II A :: Hetero Cyclic Chemistry

Time: 3 hours

Maximum Marks: 70

SECTION – A

Answer all the questions. Each question carries 2 marks.
(10x2=20M)

1. Write any one method of synthesis of Thiirane. (L-2)
2. Write any one method of synthesis of azirine. (L-2)
3. Discuss the synthesis of oxetane. (L-1)
4. Discuss the reactivity of pencillin. (L-1)
5. Write down the structures of pyrazole and imidazole. (L-1)
6. Write the structure of Indole & Benzimidazole. (L-1)
7. Write one synthesis method of pyrazine. (L-2)
8. Discuss the reactivity of Benzodiazine. (L-2)
9. Write the synthesis of azepine. (L-2)
10. Write the structure of Benzodizepine. (L-1)

SECTION – B

(10x5=50M)

UNIT – I

1. a) Write the synthesis and reactivity of Aziridines and oxiranes. (L-2)
(Or)
b) Discuss the classifications and nomenclature (Hantzsch Widman system) of heterocycles. (L-1)

UNIT – II

12. a) Write the synthesis and reactivity of Azitidines and Thietanes. (L-2)
(Or)
b) Write the synthesis of Pencillin G and V. (L-2)

UNIT – III

13. a) Write the synthesis and reactivity of Oxazole and Thiazole. (L-2)
(Or)
b) Write the synthesis and reactivity of Indole. (L-2)

UNIT - IV

14. a) Write the synthesis and reactivity of Pyridazines and Oaxazine. (L-2)
(Or)
b) Write the synthesis and reactivity of acridine. (L-2)

UNIT - V

15. a) Write the synthesis and reactivity of Oxepines and Thiepinines. (L-2)
(Or)
b) Write the synthesis and reactivity of Benzodiazepines. (L-2)

M.Sc. DEGREE EXAMINATION
FOURTH SEMESTER

Paper-II B :: GREEN CHEMISTRY

Time: 3 hours

Maximum Marks: 70

SECTION – A

Answer all the questions. Each question carries 2 marks.

(10x2=20M)

1. Write the green synthesis of urethane. (L-2)
2. Define atom economy. Explain atom economy in rearrangement reaction with a suitable example. (L-2)
3. Explain the synthesis of nitriles from aldehydes. (L-2)
4. Give the disadvantages of microwave assisted organic synthesis. (L-1)
5. Discuss the various types of phase transfer catalysts. (L-2)
6. Write the mechanism of phase transfer catalysis. (L-2)
7. Write notes on ultrasound assisted homogeneous reactions. (L-2)
8. Write notes on ultrasound assisted strecker reaction. (L-2)
9. Write notes on hydroformylation. (L-2)
10. Write an account of oxidation with ionic liquids. (L-2)

SECTION – B

(10x5=50M)

UNIT – I

1. a) Write a brief account of twelve principles of green chemistry. (L-1)
(Or)
b) Out line the green synthesis of the following compounds:
(i) Ibuprofen (ii) paracetamol (iii) catechol. (L-2)

UNIT – II

12. a) Discuss microwave assisted reactions in organic solvents. (L-2)
(Or)
b) Discuss the theory and advantages of microwave. (L-2)

UNIT – III

13. a) Define phase transfer catalyst. Write notes on C – alkylation and N – alkylation using PTC. (L-3)
(Or)
b) Discuss the synthetic applications of crown ethers. (L-3)

UNIT - IV

14. a) What is ultrasound assisted green synthesis. Discuss the instrumentation. (L-2)
(Or)
b) Write an account of the heterogeneous solid-liquid reactions. (L-2)

UNIT - V

15. a) Define ionic liquids. Mention the types of ionic liquids and properties. (L-2)
(Or)
b) Write the application of ionic liquids with respect to carbon – carbon bond formation
(i) Suzuki coupling (ii) stille coupling (L-3)

**M.Sc. DEGREE EXAMINATION
FOURTH SEMESTER**

Paper-III A:: TECHNIQUES FOR MODERN INDUSTRIAL APPLICATIONS
Time: 3 hours **Maximum Marks: 70**

SECTION – A

Answer all the questions. Each question carries 2 marks.
(10x2=20M)

1. Discuss the role of recrystallisation in purification of compounds. (L-2)
2. Explain the principle involved in batch distillation. (L-2)
3. Write the basic principle involved in TLC. (L-2)
4. Give an account on selection of mobile phase in TLC. (L-2)
5. Elaborate the basic principle involved in paper chromatography. (L-2)
6. Describe in brief about two dimensional paper chromatography. (L-2)
7. Explain the basic principle involved in Gas chromatography. (L-2)
8. List out various types of carrier gases used in Gas chromatography. (L-2)
9. What are normal phase and reverse phase techniques in HPLC? (L-2)
10. Write a short note on selection of mobile phase in HPLC. (L-2)

SECTION – B

(10x5=50M)

UNIT – I

11. a) Explain the following (i) seeding (ii) filtration (iii) centrifugation (iv) drying (L-2)

(Or)

- b) Explain the following (i) continuous distillation (ii) steam distillation. (L-2)

UNIT – II

12. a) What are the methods that are involved in the preparation of TLC plates? (L-2)

(Or)

- b) Write a note on applications of TLC. (L-2)

UNIT – III

- 13 a) Elaborate Ascending and Descending paper chromatography. (L-2)

(Or)

- b) Write applications of paper chromatography. (L-3)

UNIT - IV

- 14.a) Discuss about different types of columns used in gas chromatography. (L-3)

(Or)

- b) Explain few applications of gas chromatography.. (L-3)

UNIT - V

- 15.a) Describe instrumentation of HPLC and explain the selection of the column.(L-3)

(Or)

- b) Give a detailed account on applications of HPLC. (L-3)

M.Sc. DEGREE EXAMINATION
FOURTH SEMESTER

Paper-III B : NANO CHEMISTRY

Time: 3 hours

Maximum Marks: 70

SECTION – A

Answer all the questions. Each question carries 2 marks.
(10x2=20M)

1. What is bottom down approach? (L-1)
2. Explain the term nanoscale and nano material? (L-2)
3. Discuss the basic principle involved in TEM. (L-1)
4. Write a short note on natural and man made nano particles. (L-2)
5. What are quantum dots? Explain. (L-1)
6. List out the various types of techniques used in characterization of nanomaterials. (L-1)
7. Enumerate the role of nanomaterials in drug delivery. (L-2)
8. Give an account on biosensors. (L-2)
9. Explain in short about water strider. (L-2)
10. What is gecko foot climbing? (L-1)

SECTION – B

(10x5=50M)

UNIT – I

11. a) Define the following terms
(i) Nanoscale (ii) Nanomaterials (iii) Nanoscience (iv) Nanotechnology (L-1)

(Or)

- b) Write a note nanoscience practiced during ancient and modern periods. (L-2)

UNIT – II

12. a) Explain top down and bottom-up approaches for the synthesis of nanotubes. (L-2)

(Or)

- b) Write various methods for the synthesis of gold nanoparticles. (L-2)

UNIT – III

- 13 a) Write the principle and applications of scanning electron microscopy. (L-2)

(Or)

- b) Write the principle and applications of atomic force microscopy. (L-3)

UNIT - IV

- 14.a) Write the applications of nanomaterials in solar cells and smart materials. (L-3)

(Or)

- b) Explain the applications of detection of cancerous cells. (L-3)

UNIT - V

- 15.a) Write a note on lotus effect-self-cleaning property of lotus. (L-2)

(Or)

- b) Write a note on spider silk mechanical properties of the spider silk. (L-2)

M.Sc. DEGREE EXAMINATION
FOURTH SEMESTER

Paper-IV :: Organo Metallic Reagents

Time: 3 hours

Maximum Marks: 70

SECTION – A

Answer all the questions. Each question carries 2 marks.

(10x2=20M)

1. Explain the reaction of Grignard reagent with carbondioxide. (L-2)
2. Explain the preparation of grignard reagent with alkyl and allyl halide. (L-2)
3. What are Gilman reagents. Write any two reactions. (L-2)
4. Write the reactions of α, β – unsaturated carbonyl compounds with organocopper reagents. (L-2)
5. Write an account of suzuki coupling. (L-2)
6. Explain formation of π -allyl palladium complexes. (L-2)
7. Discuss the cyanoborate reaction. (L-2)
8. Write notes on isomerisation of organoboranes. (L-2)
9. Write an account of Peterson olefination. (L-2)
10. Write short notes of alkenyl silanes. (L-2)

SECTION – B

(10x5=50M)

UNIT – I

11. a) Explain the reaction of Grignard reagent with carbonyl compounds and Ester. (L-2)
(Or)
b) Write the preparation and uses of Lithium Di isopropyl amide (LDA). (L-2)

UNIT – II

12. a) Explain synthesis and reactions of lithium organo cuprates. (L-2)
(Or)
b) Write the synthesis and properties of π -allyl nickel complexes. (L-2)

UNIT – III

13. a) Explain the following reactions with mechanisms
(i) Heck reaction (ii) Still coupling reaction. (L-2)
(Or)
b) Explain the reactions of π – allyl palladium complexes. (L-2)

UNIT - IV

14. a) Write an account of Hydroboration. (L-2)
(Or)
b) Explain the protonolysis, oxidation, isomerisation reactions of organoboranes. (L-2)

UNIT - V

15. a) Write the synthetic applications of trimethyl silyl ethers and silyl enol ethers. (L-3)
(Or)
b) Write the synthetic applications of α -silyl carbanion and β -silyl carbonyl compound (L-3)

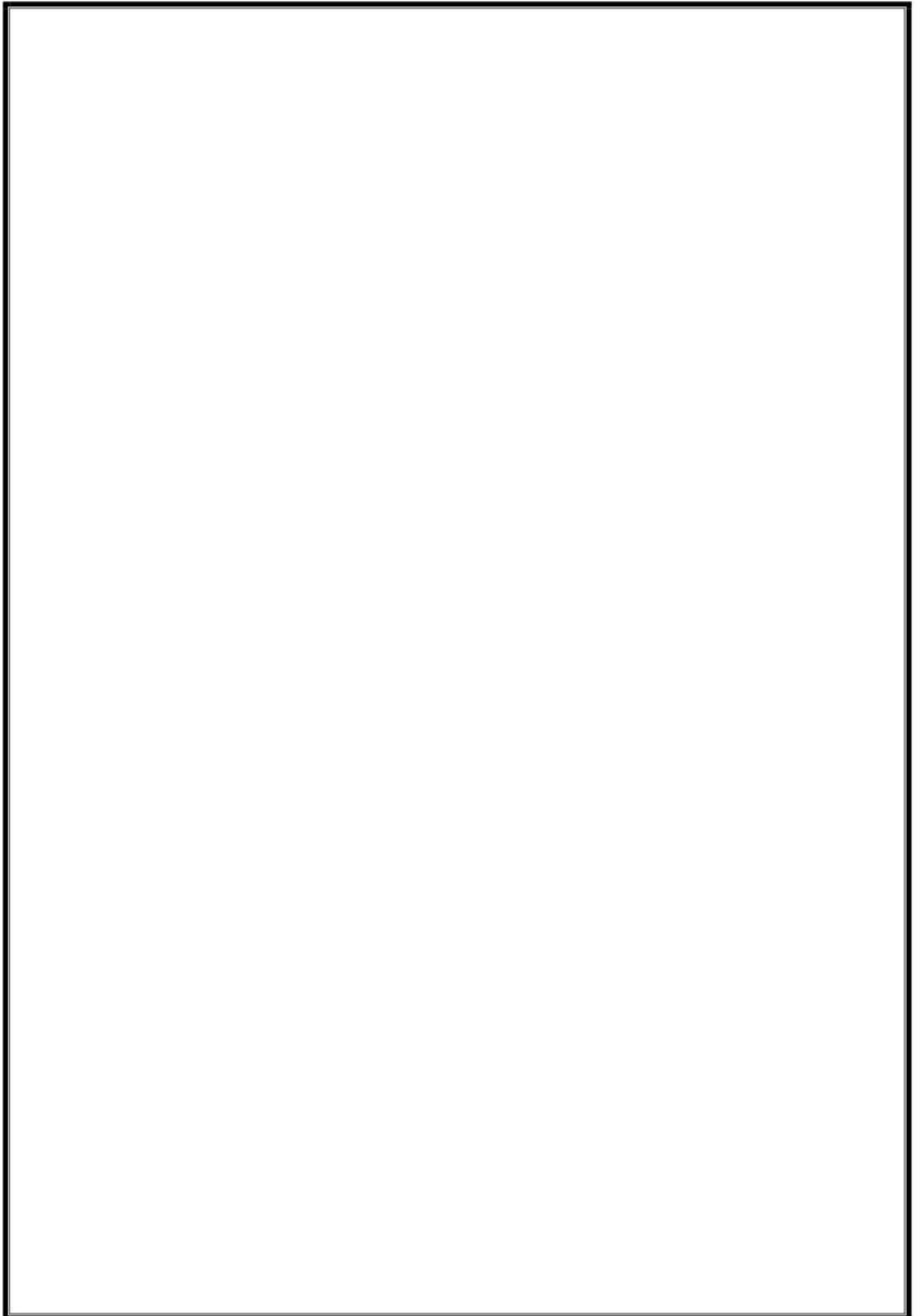

Minutes of the meeting of Board of studies in Environmental Studies for the
Autonomous courses of AG & SG Siddhartha Degree College of Arts &
Science, Vuyyuru, held at 10.30 A.M on 29-11-2021 in the

Department of ENVIRONMENTAL STUDIES

Sri R.V. Sivarao *Presiding*

Members Present:

1)..... *R.V. Sivarao* Chairman Head, Department of Environmental Studies
(Sri.R.V. Sivarao) AG & SG S Degree College of Arts & Science
Vuyyuru-521165

2)..... *B. P. Rao* University Dept of Environmental Science
(Dr.P.Brahmaji Rao) Nominee Acharya Nagarjuna University
Guntur

3)..... *K. Lakshmi* Subject Expert Dept of Zoology
(Dr.K.Lakshmi) S.D.M.Siddhartha Mahila Kalasala
Vijyawada.

4)..... *V. Sailaja* Subject Expert Lecturer in Zoology
(V.Sailaja) KTR Women's College
Gudiwada

Agenda for B.O.S Meeting

1. To recommend the syllabi for III, semester of 2nd Degree IIInd year B.A, B.Com B.Sc , Environmental Education Paper Under CBCS for the Academic year 2021-2022
2. To recommend the Teaching and Evaluation Methods to be followed under Autonomous Status.
3. Any other matter.

RESOLUTIONS

1). Discussed and Recommended The Syllabi, Model Question Papers Under CBCS and Guidelines to be followed by the Question paper Setters of III Semester of II degree B.A,B.Com , B.Sc for the Approval of the Academic Council (enclosed) for the Academic year 2021– 2022.

2). Discussed and Recommended the Teaching and evaluation methods for approval of Academic Council.

A) Teaching methods:

Besides the conventional methods of teaching, it is also resolved to use various other methods like Group discussions, Quiz, for the better understanding of the contents.

B) Evaluation of a student is done by the following procedure:

a) There is no Internal Assessment Examinations.

b) Semester-End Examinations:

i) The maximum marks for Semester-End examinations shall be 50 and duration of the examination shall be 2 Hours.

ii) Semester-End examinations shall be conducted at the end of III semester.

3) Resolved to authorize the Chairman of Board of Studies to suggest the Panel of Paper setters and Examiners to the Controller of Examinations as per the requirement.

R.V. Sivadas
Chairman



A.G & S.G.SIDDHARTHA DEGREE COLLEGE OF ARTS & SCIENCE

Vuyyuru-521165.

NAAC reaccredited at 'A' level

Autonomous -ISO 9001 - 2015 Certified

TITLE OF THE PAPER: **ENVIRONMENTAL EDUCATION**

Semester: III

Course Code	LSCT01	Course Delivery Method	Class Room / Blended Mode - Both
Credits	2	CIA Marks	-
No. of Lecture Hours / Week	2	Semester End Exam Marks	50
Total Number of Lecture Hours	30	Total Marks	50
Year of Introduction:	Year of Offering: 2021 - 22	Year of Revision: ---	Percentage of Revision: 0%
CLASS:	2 nd YEAR BA/B.Com/BSc Programmes		

Course objective:

A Generic Course intended to create awareness that the life of human beings is an integral part of environment and to inculcate the skills required to protect environment from all sides.

Learning outcomes: On completion of this course the students will be able to

1. Understand the nature, components of an ecosystem and that humans are an integral part of nature.
2. Realize the importance of environment, the goods and services of a healthy biodiversity, dependence of humans on environment.
3. Evaluate the ways and ill effects of destruction of environment, population explosion on ecosystems and global problems consequent to anthropogenic activities.
4. Discuss the laws/ acts made by government to prevent pollution, to protect biodiversity and environment as a whole.
5. Acquaint with international agreements and national movements, and realize citizen's role in protecting environment and nature.

ENVIRONMENTAL EDUCATION
Common for BA/B.Com/BSc Programmes

Semester – III

LSCT01

(Total 30 Hours)

Unit 1: Environment and Natural Resources

06 Hrs.

1. Multidisciplinary nature of environmental education; scope and importance. 2. Man as an integral product and part of the Nature. 3. A brief account of land, forest and water resources in India and their importance. 4. Biodiversity : Definition; importance of Biodiversity - ecological, consumptive, productive, social, ethical and moral, aesthetic, and option value. 5. Levels of Biodiversity: genetic, species and ecosystem diversity.

Unit-2: Environmental degradation and impacts

12Hrs

1. Human population growth and its impacts on environment; land use change, land degradation, soil erosion and desertification. 2. Use and over-exploitation of surface and ground water, construction of dams, floods, conflicts over water (within India). 3. Deforestation: Causes and effects due to expansion of agriculture, firewood, mining, forest fires and building of new habitats. 4. Non-renewable energy resources, their utilization and influences. 5. A brief account of air, water, soil and noise pollutions; Biological, industrial and solid wastes in urban areas. Human health and economic risks. 6. Green house effect - global warming; ocean acidification, ozone layer depletion, acid rains and impacts on human communities and agriculture. 7. Threats to biodiversity: Natural calamities, habitat destruction and fragmentation, over exploitation, hunting and poaching, introduction of exotic species, pollution, predator and pest control.

Unit 3: Conservation of Environment

12 Hrs

1. Concept of sustainability and sustainable development with judicious use of land, water and forest resources; afforestation. 2. Control measures for various types of pollution; use of renewable and alternate sources of energy. 3. Solid waste management: Control measures of urban and industrial waste. 4. Conservation of biodiversity: In-situ and ex-situ conservation of biodiversity. 5. Environment Laws: Environment Protection Act; Act; Wildlife Protection Act; Forest Conservation Act. 6. International agreements: Montreal and Kyoto protocols; Environmental movements: Bishnois of Rajasthan, Chipko, Silent valley.

Reference Books :

1. Environmental Studies by Dr.M.Satyanarayana, Dr.M.V.R.K.Narasimhacharyulu, Dr.G. Rambabu and Dr.V.VivekaVardhani, Published by Telugu Academy, Hyderabad.
2. Environmental Studies by R.C.Sharma, Gurbir Sangha, published by Kalyani Publishers.
3. Environmental Studies by Purnima Smarath, published by Kalyani Publishers.

AG&SG SIDDHARTHA DEGREE COLLEGE OF ARTS & SCIENCES –AUTONOMOUS

VUYYURU-521165

SEMESTER –III

MODEL QUESTION PAPER

COURSE CODE – LSCT01

Common for BA/B.Com/BSc Programmes

PAPER TITLE: ENVIRONMENTAL EDUCATION

DURATION :2 HOURS

SECTION – A

Max:50

ANSWER ANY FOUR OF THE FOLLOWING QUESTIONS

(4x5=20M)

1. Discuss about the Environmental Education.
2. What is Bio-Diversity
3. Deforestation
4. What is Global warming.
5. What is Ozone Layer
6. Forest Resources
7. Explain about Environmental laws
8. Write about Chipko Movement.

SECTION – B

ANSWER ANY THREE OF THE FOLLOWING QUESTIONS

(3x10=30M)

9. Write an essay on Forest Resource?
10. Explain the Scope and importance of Environmental Studies
11. Give an account of Renewable Energy Resource?
12. Write an essay on Air Pollution?
13. What is Sustainable Development?
14. Give an Account on Environmental Acts?

AG&SG SIDDHARTHA DEGREE COLLEGE OF ARTS & SCIENCES –AUTONOMOUS

VUYYURU-521165

The guidelines to be followed by the question paper setters in **ENVIRONMENTAL EDUCATION** for the 3rd semester – end exams (2021-22)

Common for BA/B.Com/BSc Programmes

PAPER TITLE: ENVIRONMENTAL EDUCATION

PAPER-I, SEMESTER – III

MAX :50

DURATION :2 HOURS

Weightage for the question paper

Marks	UNIT-I	UNIT-II	UNIT-III
	Environment and Natural Resources	Environmental degradation and impacts	Conservation of Environment
5Marks	2	3	3
10Marks	2	2	2
Weight age	30	25	25

AG & SG SIDDHARTHA DEGREE COLLEGE OF ARTS & SCIENCE VUYYURU
(AUTONOMOUS)
(MANAGED BY SIDDHARTHA ACADEMY OF GENERAL & TECHNICAL EDUCATION VIJAYAWADA)

(2021-22)

Syllabus for I- B.A, B.com, B.com computers B.SC MPC, MPCS,

COURSES SEMESTER-II

Course Code: LSCT06

No. of Hours per Week: 2

No. of Credits: 2

Max. Marks: 50

External: 40

Internal: 10

HUMAN VALUES AND PROFESSIONAL ETHICS (HVPE)

Learning Outcome:

On completion of this course, the UG students will be able to

- ✓ Understand the significance of value inputs in a classroom and start applying them in their life and profession.
- ✓ Distinguish between values and skills, happiness and accumulation of physical facilities, the Self and the Body, Intention and Competence of an individual, etc.
- ✓ Understand the value of harmonious relationship based on trust and respect in their life and profession.
- ✓ Understand the role of a human being in ensuring harmony in society and nature.
- ✓ Distinguish between ethical and unethical practices and start working out the strategy to actualize a harmonious environment wherever they work.

Course Objectives :

01. Understanding Value Education, its need in modern days, the basic human aspirations of happiness and prosperity. PO1
02. Understanding harmony in the family and society PO6
03. Gaining competence in Professional Ethics. PO4

UNIT: 1 Introduction – Definition, Importance, Process & Classifications of Value Education

- ❖ Understanding the need, basic guidelines, content, and process for Value Education
- ❖ Understanding the thought provoking issues; need for Values in our daily life.
- ❖ Choices making – Choosing, Cherishing & Acting
- ❖ Classification of Value Education: understanding Personal Values, Social Values, Moral Values & Spiritual Values.

UNIT: 2 Harmony in the Family – Understanding Values in Human Relationships

- ✓ Understanding harmony in the Family- the basic unit of human interaction
- ✓ Understanding the set of proposals to verify the Harmony in the Family.
- ✓ Trust (*Vishwas*) and Respect (*Samman*) as the foundational values of relationship
- ✓ Present Scenario: Differentiation (Disrespect) in relationships on the basis of body, physical facilities, or beliefs.
- ✓ Understanding the Problems faced due to differentiation in Relationships
- ✓ Understanding the harmony in the society (society being an extension of family): *Samadhan*, *Samridhi*, *Abhay*, *Sah-astitva* as comprehensive Human Goals
- ✓ Visualizing a universal harmonious order in society- Undivided Society (*AkhandSamaj*), Universal Order (*SarvabhaumiYawastha*) - from family to world



UNIT: 3 Professional Ethics in Education

- ✓ Understanding about Professional Integrity, Respect & Equality, Privacy, Building Trusting Relationships.
- ✓ Understanding the concepts: Positive co-operation, Respecting the competence of other professions.
- ✓ Understanding about Taking initiative and Promoting the culture of openness.
- ✓ Depicting Loyalty towards Goals and objectives.

Resolutions:

It is resolved to introduce new syllabus HVPE as life skills course to the students of all programmes BA, BSC, BCOM, who are admitted in the academic year 2020-2021 and onwards.

Text Books:

R R Gaur, R Sangal, G P Bagaria, 2009, A Foundation Course in Human Values and Professional Ethics.

Bhatia. R. & Bhatia, A (2015) Role of Ethical Values in Indian Higher Education

References:

- Ivan Illich, 1974, Energy & Equity, The Trinity Press, Worcester, and Harper Collins, U
- E.F. Schumacher, 1973, Small is Beautiful: a study of economics as if people mattered, Blond & Briggs, Britain.
- Sussan George, 1976, How the Other Half Dies, Penguin Press. Reprinted 1986, 1991
- Donella H. Meadows, Dennis L. Meadows, Jorgen Randers, William W. Behrens III, 1972, Limits to Growth – Club of Rome's report, Universe Books.
- A Nagraj, 1998, Jeevan Vidya EkParichay, Divya Path Sansthan, Amarkantak.
- P L Dhar, RR Gaur, 1990, Science and Humanism, Commonwealth Publishers.
- A N Tripathy, 2003, Human Values, New Age International Publishers.

Mode of Evaluation:

Assignment/ Seminar/Continuous Assessment Test/Semester End Exam.

Co curricular Activities:

1. Visit to an Old Age Home and spending with the inmates for a day.
2. Conduct of Group Discussions on the topics related to the syllabus.
3. Participation in community service activities.
4. Working with a NGO like Rotary Club or Lions International, etc.

MODEL QUESTION PAPER
Title : Human Values and Professional Ethics

COURSE CODE: LSCT06

SEMESTER-II

Max. Marks: 40

Time: 2 hours

Section – A

I. Answer any **TWO** of the following questions

2x5=10 Marks

1. What are the basic guidelines for Value Education? CO1, L1
2. What are human values? What is their significance? CO2, L2
3. What do you mean by professional ethics? Explain. CO2 L2
4. What are the values in human relationship? CO3 L1

SECTION – B

II. Answer any **THREE** of the following questions.

3x10=30 Marks

5. What is the need for value education in the present day professional oriented education? CO1 L4
6. What are the basic requirements to fulfill human aspirations of happiness and prosperity? CO1 L2
7. "Family is a natural laboratory to understand human relationships." Explain. CO3 L2
8. What do you mean by understanding values in human relationships? CO3 L3
9. What is the need and importance of professional ethics? CO2 L4
10. "If a country is to be free of corruption and a nation of beautiful minds, I strongly feel there are three key societal members who can make a difference. They are the father, the mother and the teacher"- A. P. J. Abdul Kalam. Discuss. CO4 L3
